

BS EN 58:2012
BS 2000-474:2012



BSI Standards Publication

Bitumen and bituminous binders — Sampling bituminous binders

bsi.

...making excellence a habit.™

National foreword

This British Standard is the UK implementation of EN 58:2012. It supersedes BS EN 58:2004 which is withdrawn.

The UK participation in its preparation was entrusted to Technical Committee PTI/13, Petroleum Testing and Terminology.

A list of organizations represented on this committee can be obtained on request to its secretary.

Energy Institute, under the brand of IP, publishes and sells all Parts of BS 2000, and all BS EN petroleum test methods that would be Part of BS 2000, both in its annual publication "Standard methods for analysis and testing of petroleum and related products and British Standard 2000 Parts" and individually.

Further information is available from:

Energy Institute, 61 New Cavendish Street, London W1G 7AR.

Tel: 020 7467 7100. Fax: 020 7255 1472.

This publication does not purport to include all the necessary provisions of a contract. Users are responsible for its correct application.

© The British Standards Institution 2012

Published by BSI Standards Limited 2012

ISBN 978 0 580 68831 7

ICS 91.100.50

Compliance with a British Standard cannot confer immunity from legal obligations.

This British Standard was published under the authority of the Standards Policy and Strategy Committee on 30 April 2012.

Amendments issued since publication

Amd. No.	Date	Text affected
----------	------	---------------

EUROPEAN STANDARD

EN 58

NORME EUROPÉENNE

EUROPÄISCHE NORM

April 2012

ICS 91.100.50

Supersedes EN 58:2004

English Version

Bitumen and bituminous binders - Sampling bituminous bindersBitumes et liants bitumineux - Échantillonnage des liants
bitumineuxBitumen und bitumenhaltige Bindemittel - Probenahme
bitumenhaltiger Bindemittel

This European Standard was approved by CEN on 7 January 2012.

CEN members are bound to comply with the CEN/CENELEC Internal Regulations which stipulate the conditions for giving this European Standard the status of a national standard without any alteration. Up-to-date lists and bibliographical references concerning such national standards may be obtained on application to the CEN-CENELEC Management Centre or to any CEN member.

This European Standard exists in three official versions (English, French, German). A version in any other language made by translation under the responsibility of a CEN member into its own language and notified to the CEN-CENELEC Management Centre has the same status as the official versions.

CEN members are the national standards bodies of Austria, Belgium, Bulgaria, Croatia, Cyprus, Czech Republic, Denmark, Estonia, Finland, France, Germany, Greece, Hungary, Iceland, Ireland, Italy, Latvia, Lithuania, Luxembourg, Malta, Netherlands, Norway, Poland, Portugal, Romania, Slovakia, Slovenia, Spain, Sweden, Switzerland, Turkey and United Kingdom.

EUROPEAN COMMITTEE FOR STANDARDIZATION
COMITÉ EUROPÉEN DE NORMALISATION
EUROPÄISCHES KOMITEE FÜR NORMUNG**Management Centre: Avenue Marnix 17, B-1000 Brussels**

Contents		Page
Foreword.....		3
1	Scope	4
2	Terms and definitions	4
3	Safety precautions.....	5
4	Fundamentals of sampling	5
5	Sample size	6
6	Choice of sampling method.....	6
7	Number of samples.....	8
8	Arrangements, equipment and methods of sampling	9
9	Further treatment of samples	13
Annex A (informative) Example of a form for reporting on the sampling of bituminous binders – Unique sample identification.....		27

Foreword

This document (EN 58:2012) has been prepared by Technical Committee CEN/TC 336 "Bituminous binders", the secretariat of which is held by AFNOR.

This European Standard shall be given the status of a national standard, either by publication of an identical text or by endorsement, at the latest by September 2012, and conflicting national standards shall be withdrawn at the latest by September 2012.

Attention is drawn to the possibility that some of the elements of this document may be the subject of patent rights. CEN [and/or CENELEC] shall not be held responsible for identifying any or all such patent rights.

This document supersedes EN 58:2004.

According to the CEN/CENELEC Internal Regulations, the national standards organisations of the following countries are bound to implement this European Standard: Austria, Belgium, Bulgaria, Croatia, Cyprus, Czech Republic, Denmark, Estonia, Finland, France, Germany, Greece, Hungary, Iceland, Ireland, Italy, Latvia, Lithuania, Luxembourg, Malta, Netherlands, Norway, Poland, Portugal, Romania, Slovakia, Slovenia, Spain, Sweden, Switzerland, Turkey and the United Kingdom.

1 Scope

This European Standard specifies methods of sampling bituminous binders, to determine the average quality of the material under examination and/or to determine deviations from average quality.

2 Terms and definitions

For the purposes of this document, the following terms and definitions apply.

2.1 composite sample

sample made up by the mixing of several spot samples

Note 1 to entry: A composite sample is regarded as a representative sample if the spot samples are taken according to a sampling plan which makes it probable that the composition of the composite sample approaches that of the material as closely as possible.

2.2 divided sample

sample formed by dividing a spot, composite or representative sample into several similar parts by appropriate means

2.3 flowing material

material which flows in a transport pipeline or out of the drainline of a storage container

2.4 laboratory sample

sample intended for laboratory tests

2.5 layer sample

upper, middle or lower layer spot sample taken at a specific depth in a stationary material, usually in order to detect segregation in large storage containers

2.6 main stream sample

sample taken from the outlet stream of a container, such that the entire cross-section of the outlet stream is included

2.7 material under examination

entire quantity of the bituminous binder of which the properties are to be assessed

Note 1 to entry: "Material under examination" is termed simply "material" in the body of this document.

2.8 side-stream sample

sample taken from the outlet stream by means of a sampling probe

2.9 spot sample

sample, taken in a single operation at a single place and time

Note 1 to entry: If it can be assumed that the material is homogeneous, a spot sample is regarded as a representative sample. If the material is not homogeneous, a spot sample is only regarded as representative of a limited region around the sampling point.

2.10

stationary material

material in a storage container when all valves are closed and there is no flowing in the container

2.11

surface sample

spot sample taken at less than 5 cm below the upper surface

2.12

test sample

sample produced by treatment or subdivision of a laboratory sample during preparation in the laboratory of the sample for individual tests

2.13

vertical straight-through sample

sample taken by drawing a sampling device through the total depth of the material under examination and thereby including all layers of the material

3 Safety precautions

The safety precautions given in this clause represent good practice and shall be applied in all cases where they are not in conflict with local or other regulations which shall be followed.

The list of safety precautions given in this clause is not necessarily exhaustive and they should be considered in conjunction with relevant national safety regulations and/or recognised safety code(s) for the petroleum industry.

- a) All regulations concerning entry into hazardous areas shall be observed rigorously.
- b) Equipment shall be maintained adequately.

Regular inspections of equipment should be carried out by a competent person.

- c) All equipment and access facilities shall be checked to ensure that they are adequate for safe working before commencement of sampling.
- d) Metallic sampling devices used in flammable atmospheres shall be constructed only from non-ferrous metal(s).
- e) Cords used as components of sampling devices shall be constructed only from vegetable fibre(s), e.g. manilla or sisal; for emulsions, the cord used shall not absorb water from the emulsion.

NOTE Attention is drawn to the situation that, for cords made from man-made fibres, it is possible for an operator to build up a dangerous level of electrostatic charge on his person, if he is not earthed and wearing insulating gloves, and that certain man-made fibres will melt or dissolve in hot bitumen.

- f) Precautions shall be taken to prevent the breathing of bitumen vapours during sampling operations.
- g) For samples taken from the main stream, the sampling device shall be selected such that sampling can be performed without pressure.

4 Fundamentals of sampling

- 4.1 Correct sampling techniques are a prerequisite if meaningful test results are to be obtained.
- 4.2 The person taking the sample shall be experienced in the methods to be employed.

4.3 If the sample is to be subdivided, a suitably large representative sample shall be taken and divided into the required number of divided samples.

4.4 A sampling report shall be prepared and signed by the person taking the sample.

The sampling report shall include:

- a) name and address of the manufacturer,
- b) name and address of the supplier (if different from manufacturer),
- c) object of sampling (batch number, storage container, pipe identification),
- d) nature and type of material sampled,
- e) date and time of sampling,
- f) name of the sampler,
- g) unique identification of the sample(s),
- h) number and amount of samples,
- i) sampling method used,
- j) reference to this European Standard,
- k) any deviation, by agreement or otherwise, from the procedure described in the standard,
- l) any special observations.

A prepared form shall be used for the sampling report (for example, see Annex A); a copy of the sampling report shall be placed with each divided sample. Sampling reports shall not be put into sample containers.

Because of the variety of materials for which the same container vehicle or storage tank may be used, account should always be taken of possible contamination by residues, deposits or solvents. For this reason, it is relevant to enter data in the report on the previous history of the container vehicle or storage tank.

5 Sample size

Each divided sample should consist of at least 0,5 kg material.

NOTE The required size of a laboratory sample is dependent upon the nature and extent of the tests to be carried out.

6 Choice of sampling method

The sampling method to be used depends upon:

- a) nature, quantity and temperature of the material under examination,
- b) number, type and size of the containers or cans from which the sample is to be taken,
- c) whether the sample is to be taken from a stationary or a flowing material.

Arrangements, equipment and methods of sampling are described in Clause 8.

If samples shall be taken frequently from a large volume liquid material container, sampling appliances such as sampling valves, sampling probes or three-way cocks can conveniently be installed permanently. Otherwise, liquid test materials shall be sampled by immersion techniques, for example, by weighted sampling cans or bottom closing sampling tubes; materials fluid at low temperature can be sampled from drums or containers of up to 2 m³ capacity by means of open sampling tubes. Table 1 gives an informative guideline for sampling devices.

Viscous, plastic and semi-solid material shall be sampled using tools of the kind described in 8.4, semi-solid to brittle material by means of hand-operated tools described in 8.5 and granular material or lumps according to 8.5 and 8.6.

Sampling from the main stream by disconnecting the pipe linking a container vehicle to a storage tank shall not be carried out.

Table 1 — Sampling methods for material liquid at either high or low temperatures in pipelines, containers or cans

	Sampling method		Sampling from pipelines		Sampling from containers of capacity			
			Main stream	Side stream	> 800 m ³	> 50 m ³ to 800 m ³	> 2 m ³ to 50 m ³	≤ 2 m ³ and cans
<i>Sampling using permanently installed equipment</i>	sampling probe	8.1.2	-	+	-	-	-	-
	from sampling valve	8.1.3	-	-	+	+	+	-
		8.1.4	-	+	-	-	-	-
	3-way valve	8.1.5	+	-	-	-	-	-
<i>Sampling using immersion methods</i>	weighted sampling can	8.2.1	-	-	+	+	+	(+)
	surface sampling can	8.2.2	-	-	-	-	+	-
	bottom closing sampling tube	8.2.3	-	-	-	(+)	+	+
	open sampling tube	8.2.4	-	-	-	-	-	0
	vertical straight-through can	8.2.5	-	-	-	-	+	+
<i>Sampling directly from installations</i>	from spraying equipment	8.3	+	-	-	-	-	-
Key + usable (+) limited use 0 only usable for materials fluid at low temperature - not applicable								

7 Number of samples

The number of samples taken shall be dependent upon the size and form of the container and for deliveries in cans and lumps upon the number of those in a delivery; the number of samples to be taken from a container shall be as given for each sampling method in Clause 8.

For deliveries in cans and lumps, the number of cans or lumps from which samples are to be taken shall conform to Table 2. Initially, one sample from each can or lump shall be tested. If this test shows deviation from the specification, the remaining samples shall be tested.

If sampling is intended to check homogeneity (segregation) in stationary liquid material, at least three layer samples (upper layer, middle layer and lower layer) shall be taken. They shall not be mixed to form a composite sample.

If, in exceptional circumstances, it is desired to assess the average quality from layer samples, the geometry of the container shall be taken into account.

Table 2 — Number of cans or lumps from which samples are to be taken

Total number of cans or lumps (<i>n</i>)	Number of cans or lumps sampled
2 to 8	2
9 to 27	3
28 to 64	4
65 to 125	5
126 to 216	6
217 to 343	7
344 to 512	8
513 to 729	9
730 to 1 000	10
over 1 000	$\sqrt[3]{n}$, rounded to the nearest integer above, where <i>n</i> is the total number of cans or lumps

8 Arrangements, equipment and methods of sampling

8.1 Sampling using permanently installed systems

8.1.1 Necessary drawing off before sampling.

IMPORTANT — Depending on the type of system (e.g. valve) used to take the sample and/or on the design of the unit (e.g. sampling pipe) from which the material is sampled, a draw-off shall be performed to ensure that the sample is a relevant and representative part of the material.

Each sampling point shall be assessed in order to define the minimum volume to be discarded and thus to fulfil the requirement listed above; assessment shall be reported in an appropriate document. More precisely, when a material draw-off is required (e.g. from a valve with dead volume, a long sampling pipe...), the quantity/volume of material to be taken prior sampling shall be accurately evaluated.

Any drawn off material or any sample after use, may be recycled on site or elsewhere.

NOTE It is preferable to use valves or sampling systems with zero or minimal dead volume. With valves having no dead volume, it is not necessary for any material to be drawn off before sampling.

WARNING — The sampling step on a running line shall be performed in accordance with all the appropriate safety and health practices.

8.1.2 Sampling probe. If samples shall be taken from a flowing material, it is convenient to take side-stream samples using a sampling probe installed in the delivery pipe. The sampling probe shall be installed in an upward-sloping section of the pipe or on the pressure side of the pump, or in the case of a gravity-fed system in a completely full section of pipe. The internal diameter of the sampling probe shall be less than 1/8 of the internal diameter of the delivery pipe, and its opening shall be approximately central in the pipe facing upstream. The sampling probe shall be equipped with a stop-valve. For very viscous material, it may be advantageous to arrange for the movable parts to be totally immersed in the material. Figures 1 (for pipes without pressure) and 2 show examples of suitable arrangements; the arrangements shown in Figures 1 and 2 shall be equipped with a protecting box in the sampling device.

Necessity to draw off material should be assessed (see 8.1.1 above).

If a representative sample is required, either sampling can be continuous, or spot samples can be taken by opening the stop valve at equal time intervals throughout the period of flow.

This method is usable for flowing material. For a well mixed material, a spot sample, usually taken from the middle third of the material, can be regarded as a representative sample. For material which is not well mixed, a sample taken during the whole period of flow, or a composite sample formed from at least three spot samples, shall be used.

8.1.3 Sampling valve in container walls. Sampling valves in the walls of heated containers can advantageously be installed so that the movable parts and the pipework are as far as possible within the heated material. Figure 3 shows a suitable arrangement. For this arrangement, a simple cover shall be provided for the sampling device.

Necessity to draw off material should be assessed (see 8.1.1 above).

The sample shall be drawn off into a suitable clean container or bottle.

This method is suitable for all liquid materials, whether hot or cold, and especially for containers larger than 50 m³. For a well-mixed material, a spot sample, usually from the middle third, can be regarded as a representative sample.

For material which is not well mixed, layer samples shall be taken from at least the top, middle and lower thirds.

8.1.4 Sampling valve in delivery pipes (see Clause 6). To allow side-stream samples to be taken from narrow delivery pipes, a sampling valve can be installed in place of a sampling probe in the supply line. The sampling valve shall be installed in an upward-sloping section of the supply line or on the outlet of the pump. For systems flowing under their hydrostatic head, the sampling valve shall be installed on the pressure side of the supply pipe.

Necessity to draw off material should be assessed (see 8.1.1 above).

If a representative sample is to be taken, either the sample shall be taken continuously or several spot samples shall be taken by opening the sampling valve at intervals over the whole delivery period.

This method is suitable for flowing material. For a well-mixed material, a spot sample, usually taken during the delivery of the middle third of the material, can be regarded as a representative sample. For a material which is not well mixed, a representative sample shall be obtained either by continuous sampling over the whole delivery period or by combining at least three spot samples.

If thoroughly mixed material is unloaded from a container vehicle, the sample shall be taken during the delivery of the middle third of the material.

An example of a suitable valve is shown in Figures 4 and 5.

8.1.5 Three-way valves (see Clause 6)

If samples of flowing material are to be taken from narrow pipes, e.g. on mixing plants, the installation of an easily accessible 3-way valve is convenient. The cock shall have an internal diameter appropriate to the size of the pipe, and shall be installed with the sampling outlet pointing downwards. The length of the pipe leading to the outlet shall be as short as possible. Figures 6 and 7 show an example of a three-way valve.

Necessity to draw off material should be assessed (see 8.1.1 above).

If a representative sample is to be obtained, several spot samples shall be taken by opening the three-way valve at equal time intervals over the whole supply period.

This method is suitable for all liquid materials in narrow pipes.

For well-mixed materials, a spot sample can be regarded as a representative sample, but for materials which are not well mixed, a composite sample shall be formed from at least three spot samples.

If a well-mixed material is unloaded from a container vehicle, the sample shall be taken during the delivery of the second third of the material.

8.2 Sampling using submersible equipment

The procedures described in 8.2 use permanently installed sampling devices and the depth from which the sample is taken is therefore fixed in advance without reference to the depth to which the tank may be filled at the time of sampling. By the use of submersible equipment, samples can be taken from any depth.

8.2.1 Weighted sampling can. A weighted sampling can shall be used for sampling liquid materials and a typical example for high viscosity materials is shown in Figures 8 and 9. For very fluid materials, a weighted sampling can of the type shown in Figure 10 may be used.

Clean the sampling can and close it with the bung; lower it by the suspension to the chosen depth in the tank. Take a layer sample by withdrawing the bung with a short jerk on the suspension. The sampling equipment shall then be held at a constant depth until it is full as indicated by a cessation in the formation of air bubbles.

NOTE The opening in the flask or can is small in comparison with its volume, so that there is no significant contamination of the sample by material from other layers during the subsequent slow withdrawal of the sampling appliance.

The method is suitable for sampling fluid material in a storage tank. For well-mixed material and storage tanks of up to 50 m³ capacity, one spot sample, usually taken from the middle third, can serve as a representative sample. For less well-mixed material and storage tanks greater than 50 m³ capacity, samples shall be taken from at least the top, middle and lower third of the material.

8.2.2 Surface sampling can. A surface sampling can shall be used to take top surface samples of liquid material in tanks up to 50 m³ capacity, e.g. road tankers. This consists of a clean, open-top can, of suitable diameter, in a holder, e.g. a laboratory stand, which also serves as a ballast weight. The length of the holder shall permit the can to be lowered through the tank opening, and submerged below the surface of the material. Figures 11 and 12 show an example of a suitable holder.

Take a sample by fixing a clean can in the holder and submerging the can just below the surface of the test material.

8.2.3 Bottom-closing sampling tube (thief). A bottom-closing sampling tube consists of a tube, the upper end of which carries a handle linked to a shut-off disc at the lower end. For use in taking straight-through samples, the length of the sampling tube shall be at least equal to the depth of the material in the container. An example of a suitable arrangement is shown in Figure 13.

8.2.4 Open sampling tube (thief). An open sampling tube consists of a tube of appropriate length and diameter, conical in shape at the top and bottom ends. For sampling emulsions, tubes constructed of glass or plastics material shall be used. Figure 14 shows an example of a suitable arrangement.

Take a sample by inserting the clean tube to the required depth in the tank with its upper end closed by the thumb or a bung. Open the upper end so that the liquid rises in the tube; re-close the upper end and carefully withdraw the tube complete with the sample from the tank. Without wiping the exterior of the tube, allow the sample to flow into a sample container by opening the top end.

Open sampling tubes are suitable for sampling material in drums or barrels. Barrels containing emulsions shall be rolled over and stirred thoroughly with a rod by hand; rolling the barrel over alone is not sufficient.

8.2.5 Vertical straight through sampling can. A vertical straight through sampling can shall be used to take a vertical straight-through sample of homogeneous liquid material from tanks of up to 50 m³ capacity, e.g. road tankers. This consists of a clean open-top sampling can of approximately 500 ml and of suitable diameter, with a secure fixing to a rod of sufficient length to permit the can to be lowered through the tank opening, and submerged below the surface of the material down to the bottom of the tank; normally, an elongation rod is required for this (see Figure 12).

Attach the elongation rod securely to the sampling can, immerse the assembly in the material and move it up and down to ensure thorough mixing of the material in the can with that outside of it. Lift the assembly out of the material and place it directly into a despatch container of approximately 1 000 ml without touching the sampling can. Close the sampling can, detach the elongation rod and close the despatch container.

NOTE The lid of the sampling can will remain cool for a short period after closure, and it is possible to detach the elongation rod easily whilst pressing down on the lid of the sampling can inside the despatch container, when both are situated on the ground.

8.3 Sampling from spraying equipment

Spot samples from spraying equipment shall be taken from the drainage valve or tap while the material is being circulated through the equipment.

Necessity to draw off material should be assessed (see 8.1 above).

Two samples shall be taken of the middle third of the container. Immediately after taking each spot sample, the sample container shall be closed securely. If the sample is hot, apply a loose placed lid until the sample has cooled down.

8.4 Sampling using split sampling tubes

For taking samples from plastic to semi-solid materials, a sampling tube, opening along its length, can be used. The length shall be sufficient to allow the sample to be taken from the whole depth of the material. Figure 15 shows an example of a suitable arrangement.

Expose the upper face of the material as necessary. If necessary, warm the open sampling tube and insert it into the test material down to the desired depth, at a point not less than 75 mm from any edge, close the two halves of the tube and withdraw it together with the sample.

This method can be used for sampling plastic to semi-solid materials in drums.

If the material is too hard for sampling with the split sampling tube, a hand tool should be used, as described in 8.6. If the material is too soft and runs out of the split sampling tube, an open sampling tube (8.2.4) should be used.

8.5 Sampling using hand tools

8.5.1 Semi-solid to solid, unpulverized material, delivered in drums or cans, shall first be freed from the container. Take the sample using a clean suitable tool including the entire vertical section. No material from within 50 mm of the boundary shall be included in the sample.

8.5.2 Material in lumps shall be cut into two. The sample shall be taken from the centre of the material using clean tools.

8.6 Sampling by coning and quartering

Sampling of granular material is carried out in a sample splitter or by coning, quartering, mixing and discarding until the required test quantity is obtained; this ensures that the divided samples are of the same quality.

If the granular material is wrapped or packaged, pour it into a clean tray. Remove a minimum of 20 shovelfuls (as spot samples) so that the granular material is representative for the material under examination; use shovels with steeply curved sides, e.g. stokers shovels. Make a pile of the material from the spot samples on a clean sampling sheet of at least 120 cm x 240 cm and turn the material over twice. The purpose of the coning is to compensate for any separation. Divide the material into four portions, remix these thoroughly and spread the material out into a circle, quarter it and discard two diagonally opposite quarters. Repeat this mixing and quartering of the remaining material until only the quantity required for four divided samples remains (see Clause 5). Divide this material again into four quarters; each quarter then represents one divided sample. If only three divided samples are required, discard the fourth quarter. The procedure is illustrated in Figure 16.

9 Further treatment of samples

9.1 General

Combination of spot samples to form a composite sample, as well as mixing and subdividing of samples shall be carried out immediately after taking the sample, with no break in continuity, so that material fluid only at high temperatures remains pourable, or no loss of volatiles occurs with test material containing solvents. It is preferable that the work is carried out under cover, e.g. in a laboratory.

9.2 Sample and despatch containers or bottles

Sample containers and bottles shall be used to hold samples taken from sampling appliances or from permanent sampling facilities, combination containers and bottles shall be used for combining spot samples to form composite samples, and despatch containers shall be used for despatching. The containers or bottles shall be clean and dry before use.

The use of separate containers or bottles for each spot sample is particularly necessary when it is desired to derive an average sample from spot samples, taking the geometry of the storage tank into account.

For material which is fluid only when hot, unlacquered steel or tin-plate cans or jars with a wide opening and preferably with a spout are suitable sample and despatch containers (see 9.5, 5th paragraph). For despatch containers, only unlacquered, folded steel containers with well closed press-on lids are suitable.

For material fluid at low temperature other than emulsions, unlacquered tin-plate screw top cans, glass or suitable plastic jars can be used as despatch containers. Containers and bottles with narrow openings are recommended for sample and combination containers since this reduces, as far as possible, evaporation of lighter fractions.

For emulsions, only glass or plastic bottles shall be used for sample, combination or despatch containers. The use of glass bottles for despatching shall only be allowed when precautions have been taken to prevent their damage during transport.

For hard or granular test materials, bags or cartons of suitable materials or tins with press-on lids can be used. Samples from materials on rolls shall be rolled around a core with a diameter of at least 80 mm and packed in a tube.

9.3 Preparation of composite samples

Composite samples shall be prepared from spot samples if a representative sample is to be produced from spot samples, or the sample size required necessitates combining several spot samples, e.g. 5 kg of emulsion, drawn by using a small open sampling tube.

When spot samples are combined to form a composite sample, they shall be combined in the same volume ratio as the volumes of the test material to which they correspond.

Hot-flowing and cold-flowing materials shall be combined by pouring into a combination container and mixing until homogeneous without affecting the representative nature of the samples (e.g. polymer modified bitumens).

For viscous, plastic or semi-hard test materials, the spot samples shall be removed from the sampling tube, if necessary after gentle warming, and placed either in sample containers or directly into the combination container. The samples are warmed carefully and with constant agitation, placed in the combination container and mixed until homogeneous.

Composite samples of granular material, or of material broken up for sampling, shall be prepared at the point of sampling (see 8.5 and 8.6).

9.4 Splitting into divided samples

After homogenizing (see 9.3), spot or composite samples of liquid or molten viscous materials shall be immediately split into equally divided samples and placed into similar, clean despatch containers or bottles fitted with lids (see 4.3). The containers or the bottles shall be immediately closed tightly.

Divided samples of granular material shall be prepared at the sampling site (see 8.6).

9.5 Packaging, marking and despatch

All divided samples shall be clearly and durably labelled with a unique sample identification to correspond with the sampling report (see 4.4), either on the container (but not on the lid) or on a label attached to the container. The same labelling shall not be repeated by the manufacturer (or supplier) within a 3-year period.

Divided samples should be numbered sequentially, both on the labels and in the reports.

If the samples are intended to determine deviations from average quality, this shall be stated on the package or on the label.

For samples of emulsions, the despatch container shall be completely filled, and the temperature of the emulsion during storage and transport shall not be lower than 5 °C. Sample despatch containers shall be kept tightly closed until required.

Sample containers, other than strong steel cans or drums, should be adequately protected against damage before and during despatch and transport.

The supplier's instructions on storing emulsions should be followed.

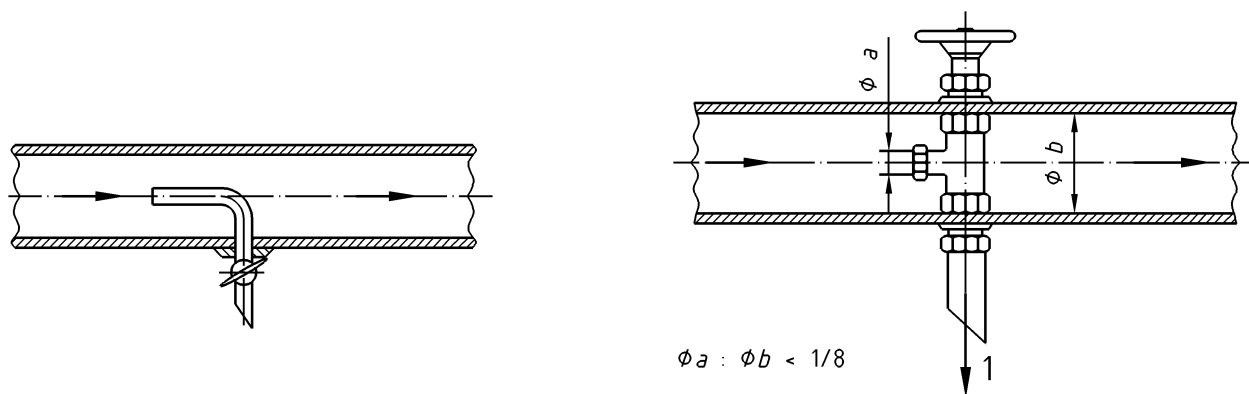

Key

1 sample outlet

Figure 1 — Sampling probe with an outside stop-valve

Figure 2 — Sampling probe with an inside stop valve

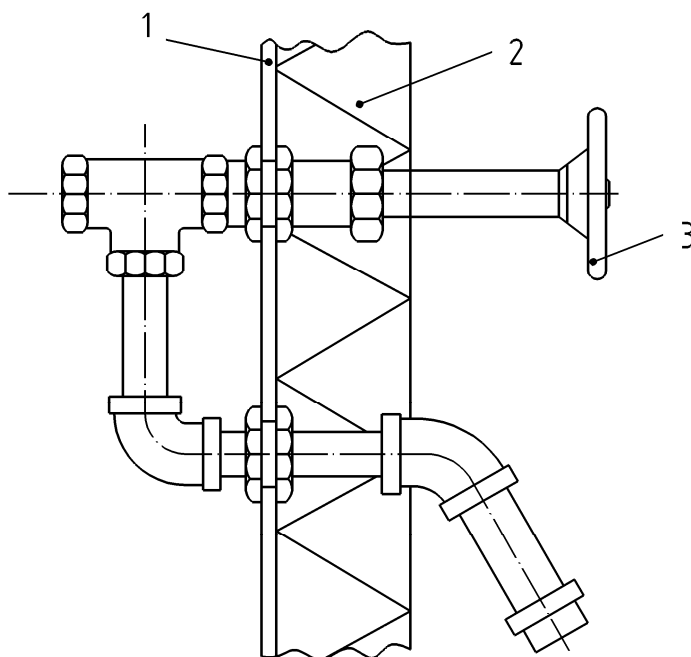

Key

- 1 tank shell
- 2 insulation
- 3 stop valve

Figure 3 — Sampling valve in an insulated container wall

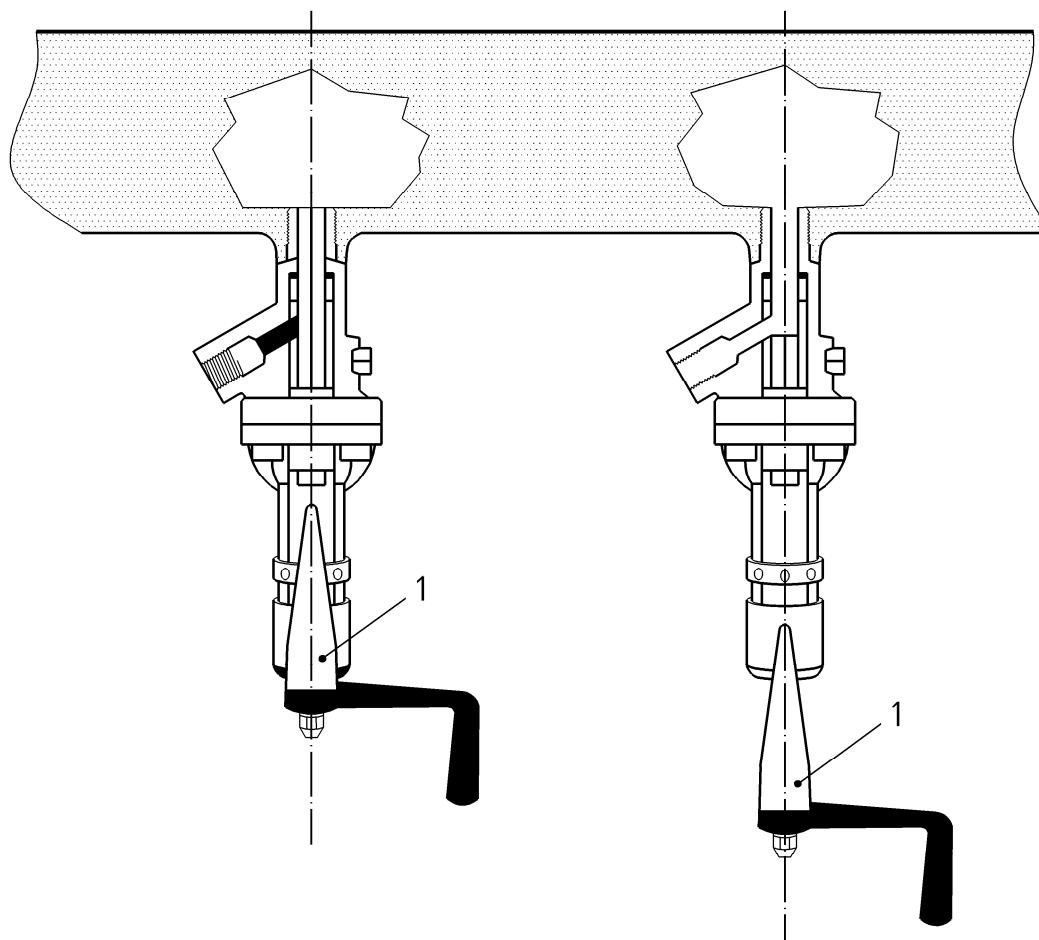

a) Closed position

b) Open position

Key

1 opening indicator

Figure 4 — Piston-type sampling valve

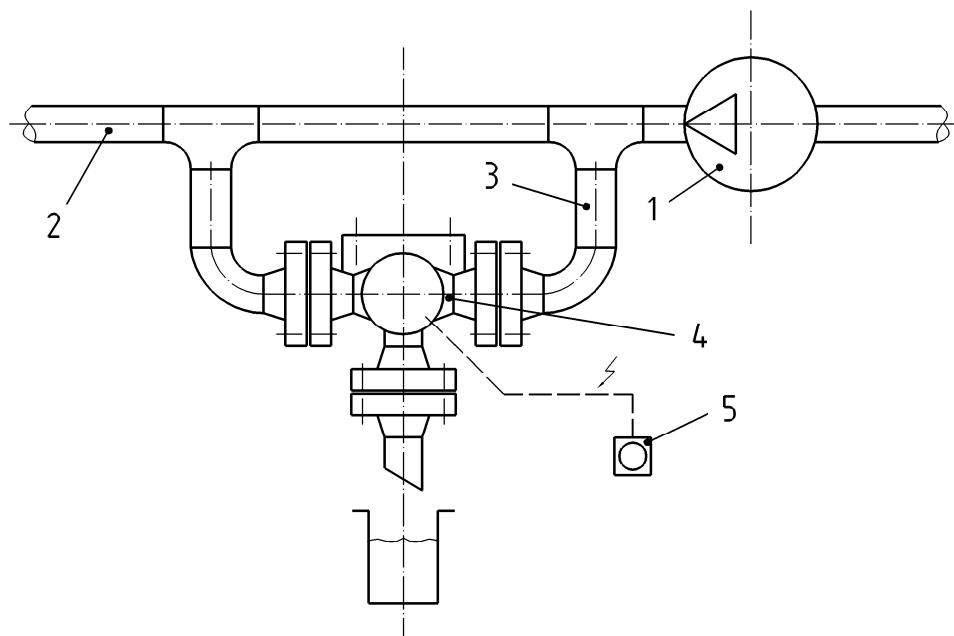

Key

- 1 pump
- 2 pipes to tank
- 3 bypass
- 4 sampling device
- 5 action button at a distance

**Figure 5 — Sampling device in an asphalt production installation
(positioned between tank and scales)**

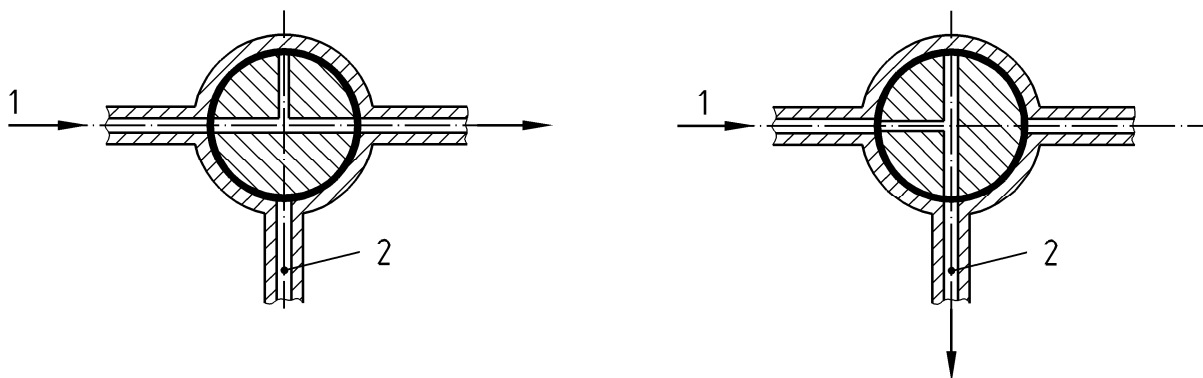

a) Position A: sample outlet closed

b) Position B: sample outlet open

Key

- 1 main stream
- 2 sample outlet

Figure 6 — Three-way valve in a pipeline

Dimensions in millimetres

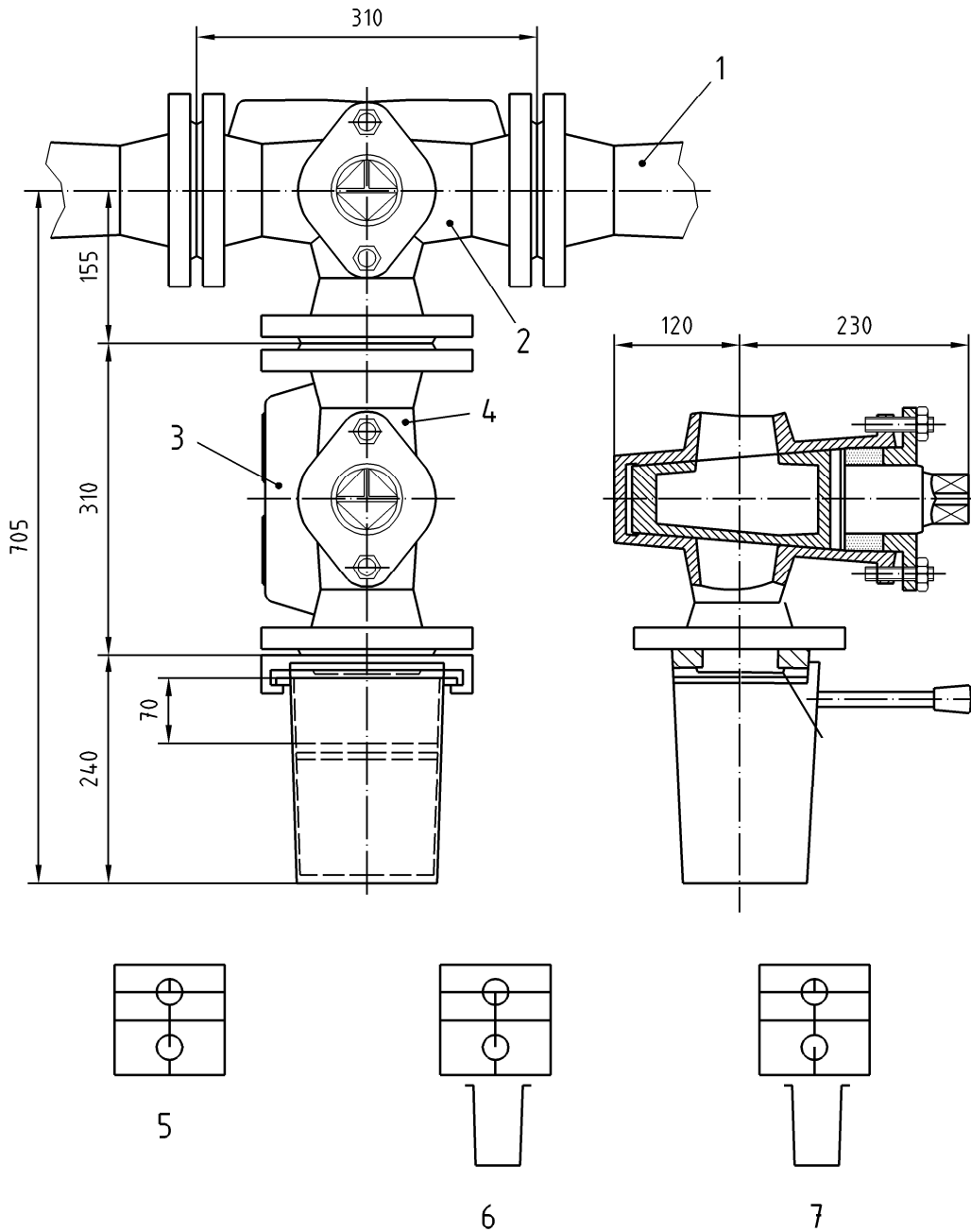

Key

- 1 pressure piping
- 2 three-way valve
- 3 heating pipe
- 4 two-way valve
- 5 normal
- 6 filling the space in between
- 7 volume of the space to the container

NOTE Dimensions in mm are approximate.

Figure 7 – Three-way valve

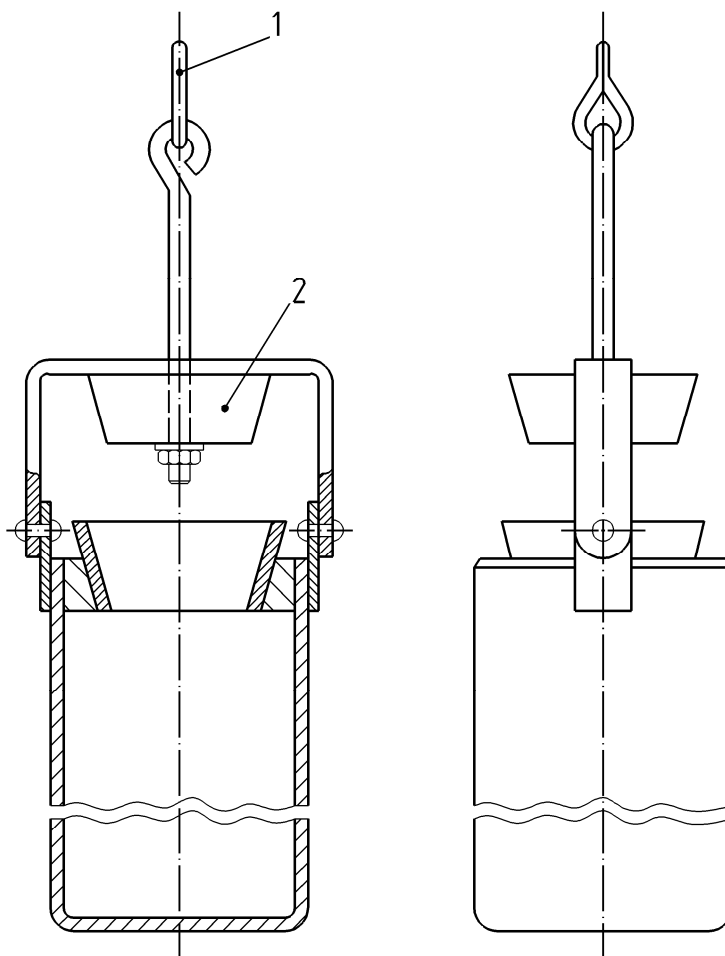

Key

- 1 steel wire PTFE covered
- 2 PTFE bung

Figure 8 — Sampling can: typical arrangement

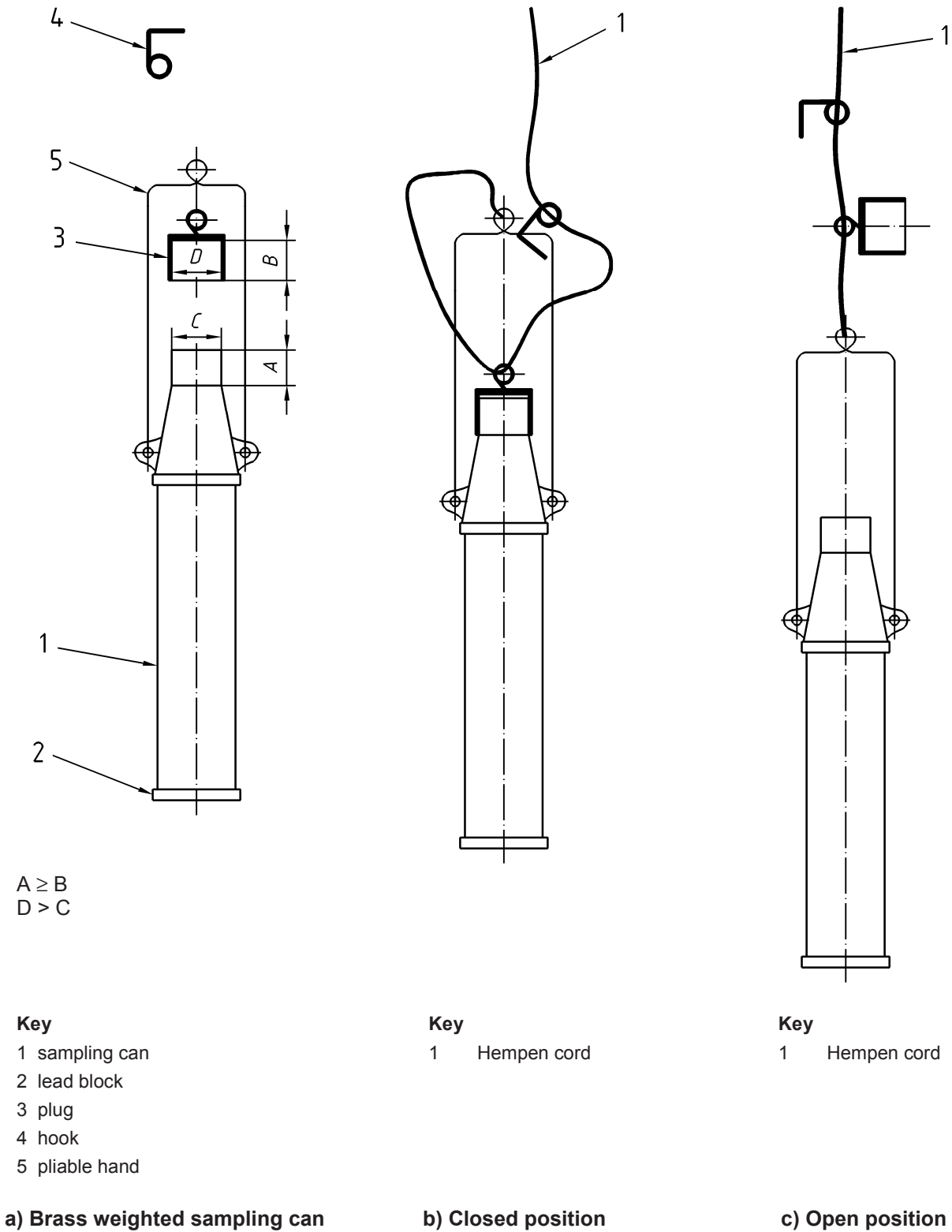
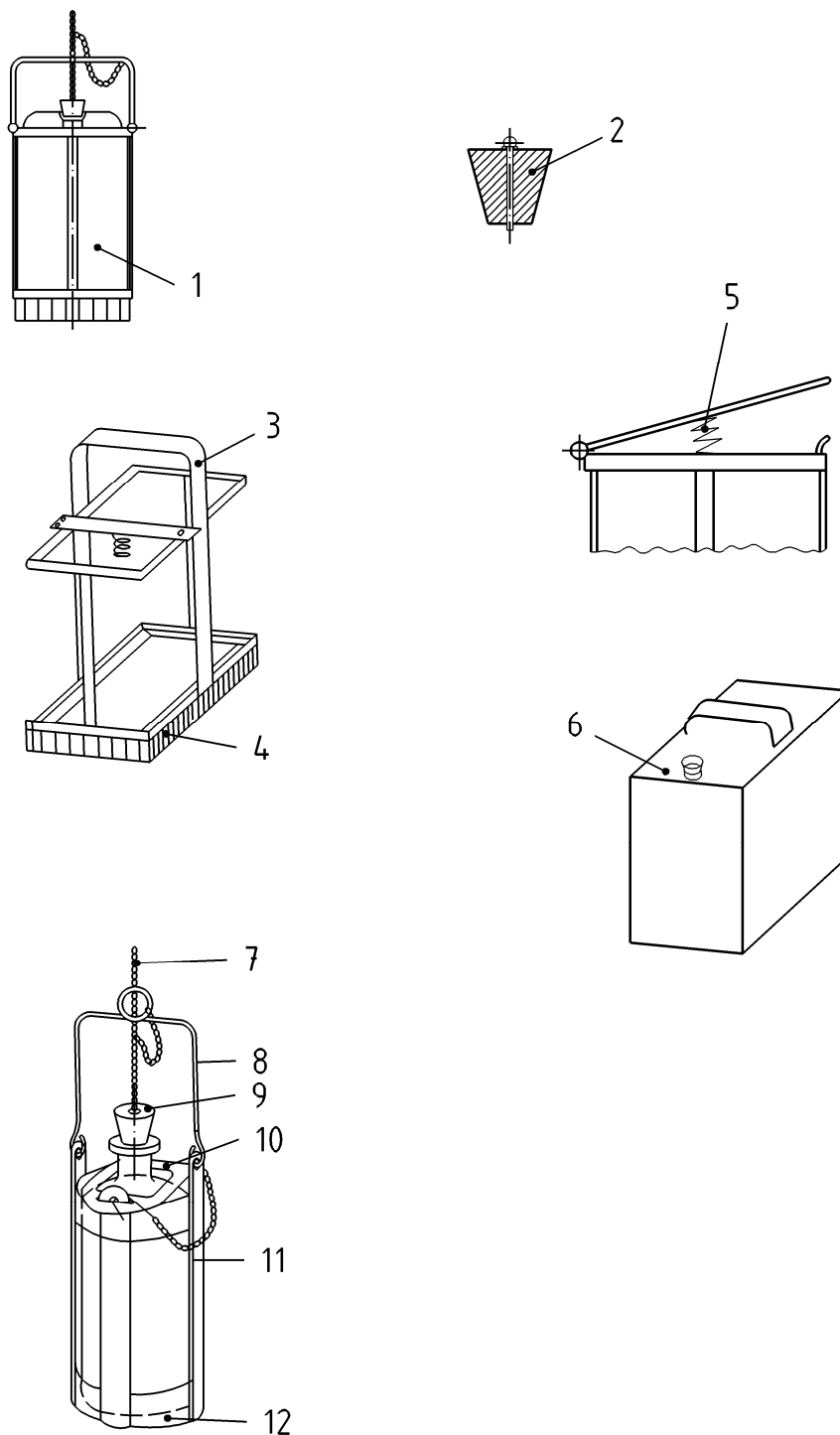

Figure 9 — Weighted sampling can



Key

- | | | | |
|---|----------------------|----|------------------------------------|
| 1 | can in weighted cage | 7 | brass or hemp line |
| 2 | bung | 8 | copper wire handle |
| 3 | weighted cage | 9 | bung |
| 4 | loading weight | 10 | hinged collar to retain sample can |
| 5 | can-retaining spring | 11 | copper strip |
| 6 | can | 12 | lead base |

Figure 10 — Typical weighted sampling cans and cages

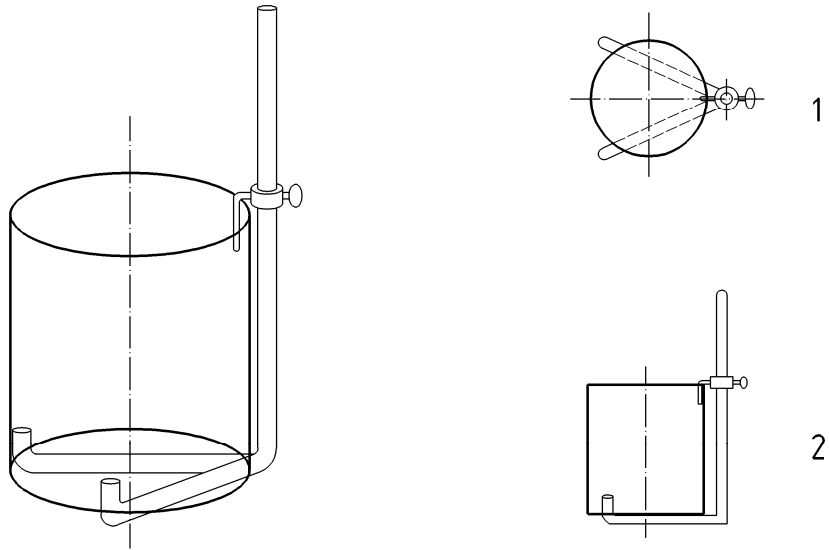

Key

- 1 bottom view
- 2 side view

Figure 11 — Typical holder for a surface sampling can

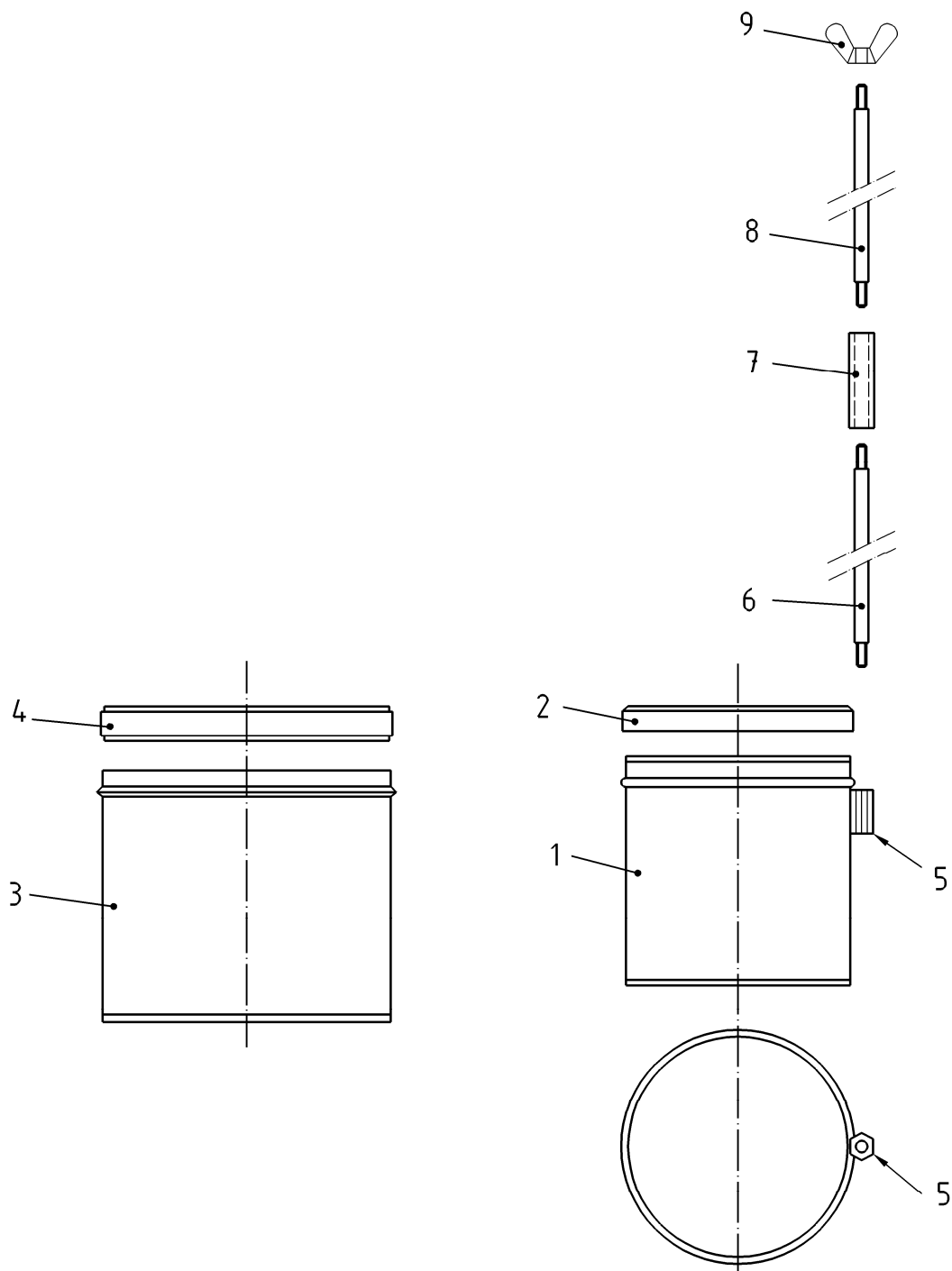

Key

- 1 tin 500 ml with screw
- 2 lid for tin 500 ml
- 3 tin 1 000 ml for placing the hot sample (in 500 ml tin)
- 4 lid for the 1 000 ml tin
- 5 screw, soldered (temperature resistant) at 500 ml tin

- 6 rod with screws on both ends
- 7 connection (sleeve)
- 8 elongation rod with screws on both ends
- 9 bolt

All screws M6

Figure 12 — Vertical straight-through and surface sampling can

Dimensions in millimetres

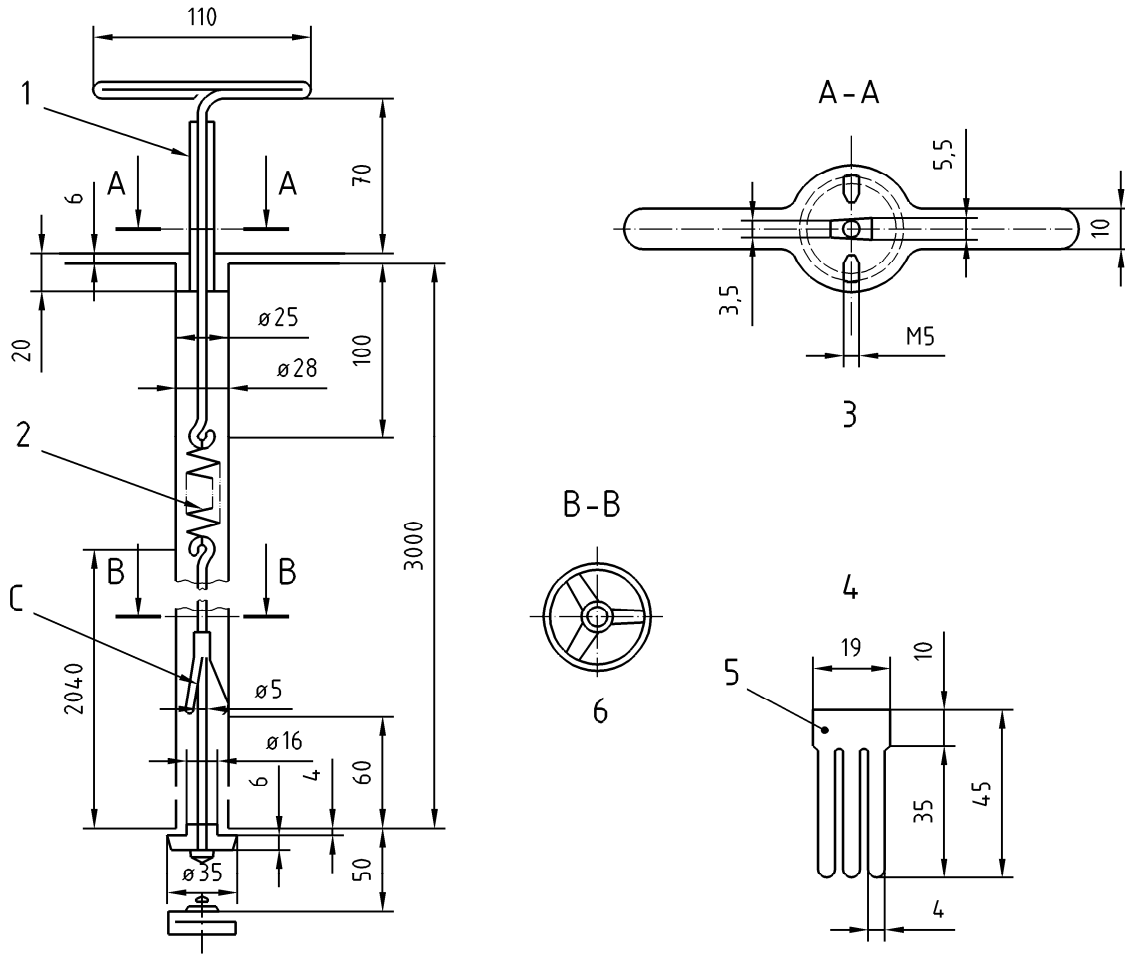

Key

- 1 3 mm Ø wire hard soldered
- 2 2 mm Ø steel wire, 8 turns, free length 60 mm, extended length 80 mm
- 3 view A-A
- 4 detail of part C
- 5 spring steel 1 thick
- 6 view B-B

NOTE Dimensions in mm are approximate.

Figure 13 — Bottom closing sampling tube (thief)

Dimensions in millimetres

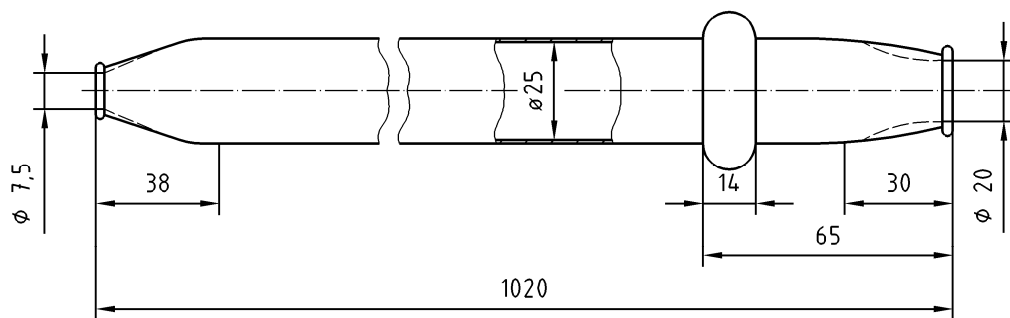

NOTE Dimensions in mm are approximate.

Figure 14 — Open sampling tube (thief)

Dimensions in millimetres

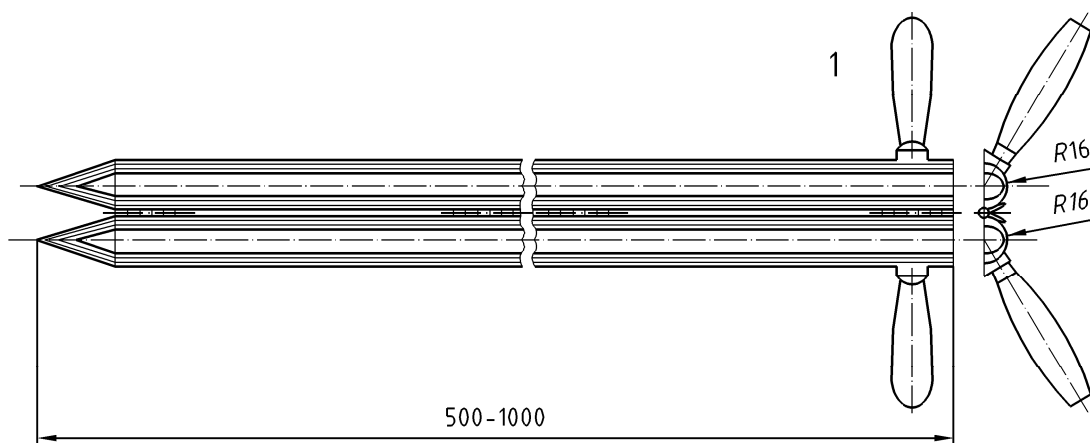

Key

1 enlarged side view

NOTE Dimensions in mm are approximate.

Figure 15 — Split sampling tube

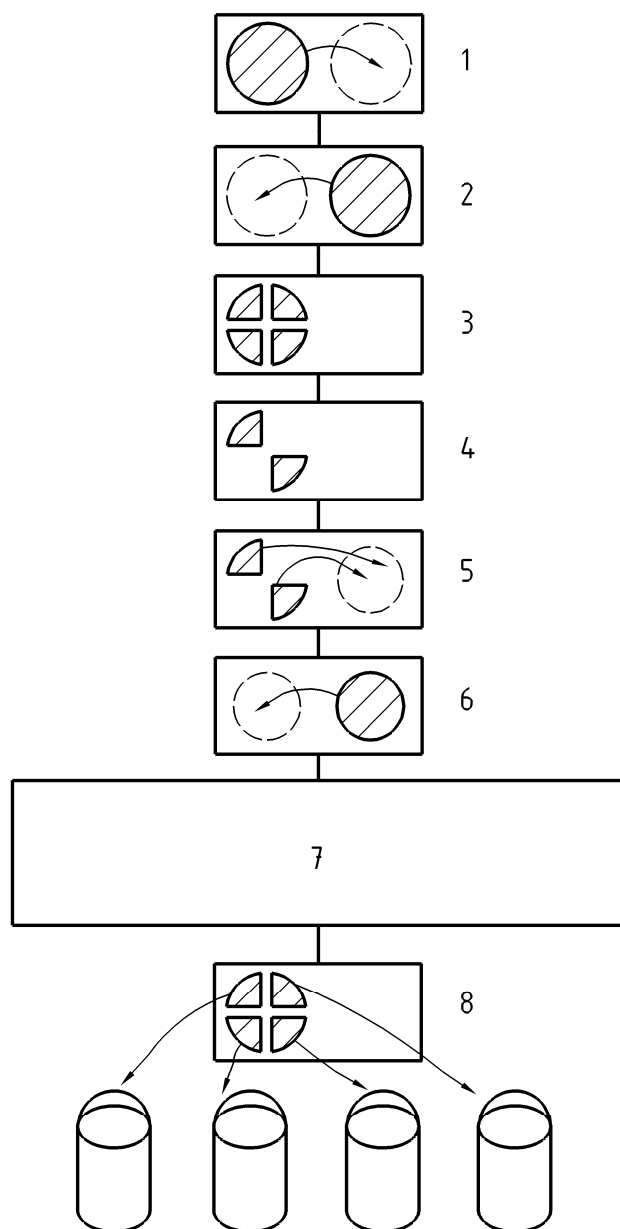

Key

- 1 turning over
- 2 turning over
- 3 quartering
- 4 discarding
- 5 mixing
- 6 turning over
- 7 The turning over, quartering and mixing should be repeated until only the quantity required for four divided samples remains.
- 8 division

Figure 16 — Scheme for dividing a sample of granular material

Annex A (informative)

Example of a form for reporting on the sampling of bituminous binders – Unique sample identification

A.1 Data on material under examination

- A.1.1** Amount and description of the sample.
- A.1.2** Nature and type of material under examination.
- A.1.3** Object of sampling (batch number, storage container, pipe identification).

A.2 Data on delivery and use

- A.2.1** Name and address of the manufacturer.
- A.2.2** Name and address of the supplier (if different from manufacturer).
- A.2.3** Delivery address and recipient if required.

A.3 Data on sampling

- A.3.1** Date and time of sampling.
- A.3.2** Name of the sampler.
- A.3.3** Number and amount of samples.
- A.3.4** Sampling method used.
- A.3.5** Data on sample, including consistency of material under examination.
- A.3.6** Distribution of sample.
- A.3.7** Reference to this European Standard.
- A.3.8** Any deviation, by agreement or otherwise, from the procedure described in the standard.
- A.3.9** Special observations, comments and notes.

Buying Parts of BS 2000

Orders for BS 2000 publications should be addressed to either:

Energy Institute – Library and Information Service

61 New Cavendish Street
London
W1G 7AR

Tel: +44 (0)20 7467 7100

Fax: +44 (0)20 7255 1472

www.energyinst.org.uk

Order standards securely via:

www.energyinstpubs.org.uk

or:

British Standards Institution – Customer Services

389 Chiswick High Road
London
W4 4AL

Tel: +44 (0)20 8996 9001

Fax: +44 (0)20 8996 7001

www.bsi-global.com

Order hard copy standards securely via:

www.bsi-global.com/bsonline

Copyright

Copyright exists in all BS 2000 publications. No part of this publication may be reproduced in any form without the prior permission in writing of BSI and the Energy Institute. Enquiries about copyright should be made to the Secretary of PTI/13 at the Energy Institute.



British Standards Institution (BSI)

BSI is the national body responsible for preparing British Standards and other standards-related publications, information and services.

BSI is incorporated by Royal Charter. British Standards and other standardization products are published by BSI Standards Limited.

About us

We bring together business, industry, government, consumers, innovators and others to shape their combined experience and expertise into standards-based solutions.

The knowledge embodied in our standards has been carefully assembled in a dependable format and refined through our open consultation process. Organizations of all sizes and across all sectors choose standards to help them achieve their goals.

Information on standards

We can provide you with the knowledge that your organization needs to succeed. Find out more about British Standards by visiting our website at bsigroup.com/standards or contacting our Customer Services team or Knowledge Centre.

Buying standards

You can buy and download PDF versions of BSI publications, including British and adopted European and international standards, through our website at bsigroup.com/shop, where hard copies can also be purchased.

If you need international and foreign standards from other Standards Development Organizations, hard copies can be ordered from our Customer Services team.

Subscriptions

Our range of subscription services are designed to make using standards easier for you. For further information on our subscription products go to bsigroup.com/subscriptions.

With **British Standards Online (BSOL)** you'll have instant access to over 55,000 British and adopted European and international standards from your desktop. It's available 24/7 and is refreshed daily so you'll always be up to date.

You can keep in touch with standards developments and receive substantial discounts on the purchase price of standards, both in single copy and subscription format, by becoming a **BSI Subscribing Member**.

PLUS is an updating service exclusive to BSI Subscribing Members. You will automatically receive the latest hard copy of your standards when they're revised or replaced.

To find out more about becoming a BSI Subscribing Member and the benefits of membership, please visit bsigroup.com/shop.

With a **Multi-User Network Licence (MUNL)** you are able to host standards publications on your intranet. Licences can cover as few or as many users as you wish. With updates supplied as soon as they're available, you can be sure your documentation is current. For further information, email bsmusales@bsigroup.com.

BSI Group Headquarters

389 Chiswick High Road London W4 4AL UK

Revisions

Our British Standards and other publications are updated by amendment or revision.

We continually improve the quality of our products and services to benefit your business. If you find an inaccuracy or ambiguity within a British Standard or other BSI publication please inform the Knowledge Centre.

Copyright

All the data, software and documentation set out in all British Standards and other BSI publications are the property of and copyrighted by BSI, or some person or entity that owns copyright in the information used (such as the international standardization bodies) and has formally licensed such information to BSI for commercial publication and use. Except as permitted under the Copyright, Designs and Patents Act 1988 no extract may be reproduced, stored in a retrieval system or transmitted in any form or by any means – electronic, photocopying, recording or otherwise – without prior written permission from BSI. Details and advice can be obtained from the Copyright & Licensing Department.

Useful Contacts:

Customer Services

Tel: +44 845 086 9001

Email (orders): orders@bsigroup.com

Email (enquiries): cservices@bsigroup.com

Subscriptions

Tel: +44 845 086 9001

Email: subscriptions@bsigroup.com

Knowledge Centre

Tel: +44 20 8996 7004

Email: knowledgecentre@bsigroup.com

Copyright & Licensing

Tel: +44 20 8996 7070

Email: copyright@bsigroup.com



...making excellence a habit.™