

Fire detection and fire alarm systems —

Part 20: Aspirating smoke detectors

The European Standard EN 54-20:2006 has the status of a British Standard

ICS 13.220.20

National foreword

This British Standard is the official English language version of EN 54-20:2006.

The UK participation in its preparation was entrusted by Technical Committee FSH/12, Fire detection and alarm systems, to Subcommittee FSH/12/2, Fire detectors, which has the responsibility to:

- aid enquirers to understand the text;
- present to the responsible international/European committee any enquiries on the interpretation, or proposals for change, and keep UK interests informed;
- monitor related international and European developments and promulgate them in the UK.

A list of organizations represented on this subcommittee can be obtained on request to its secretary.

Cross-references

The British Standards which implement international or European publications referred to in this document may be found in the *BSI Catalogue* under the section entitled “International Standards Correspondence Index”, or by using the “Search” facility of the *BSI Electronic Catalogue* or of British Standards Online.

This publication does not purport to include all the necessary provisions of a contract. Users are responsible for its correct application.

Compliance with a British Standard does not of itself confer immunity from legal obligations.

Summary of pages

This document comprises a front cover, an inside front cover, the EN title page, pages 2 to 80, an inside back cover and a back cover.

The BSI copyright notice displayed in this document indicates when the document was last issued.

Amendments issued since publication

| Amd. No. | Date | Comments |
|----------|------|----------|
| | | |
| | | |
| | | |
| | | |

This British Standard was published under the authority of the Standards Policy and Strategy Committee on 30 June 2006

© BSI 2006

ISBN 0 580 48870 5

ICS 13.220.20

English Version

Fire detection and fire alarm systems - Part 20: Aspirating smoke detectors

Systèmes de détection et d'alarme incendie - Partie 20 :
DéTECTEURS DE FUMÉE PAR ASPIRATION

Brandmeldeanlagen - Teil 20: Ansaugrauchmelder

This European Standard was approved by CEN on 18 May 2006.

CEN members are bound to comply with the CEN/CENELEC Internal Regulations which stipulate the conditions for giving this European Standard the status of a national standard without any alteration. Up-to-date lists and bibliographical references concerning such national standards may be obtained on application to the Central Secretariat or to any CEN member.

This European Standard exists in three official versions (English, French, German). A version in any other language made by translation under the responsibility of a CEN member into its own language and notified to the Central Secretariat has the same status as the official versions.

CEN members are the national standards bodies of Austria, Belgium, Cyprus, Czech Republic, Denmark, Estonia, Finland, France, Germany, Greece, Hungary, Iceland, Ireland, Italy, Latvia, Lithuania, Luxembourg, Malta, Netherlands, Norway, Poland, Portugal, Romania, Slovakia, Slovenia, Spain, Sweden, Switzerland and United Kingdom.



EUROPEAN COMMITTEE FOR STANDARDIZATION
COMITÉ EUROPÉEN DE NORMALISATION
EUROPÄISCHES KOMITEE FÜR NORMUNG

Management Centre: rue de Stassart, 36 B-1050 Brussels

Contents

Page

| | |
|---|----|
| Foreword..... | 4 |
| 1 Scope..... | 6 |
| 2 Normative references | 6 |
| 3 Terms and definitions..... | 7 |
| 4 Symbols and abbreviations | 7 |
| 5 Requirements | 8 |
| 5.1 Compliance..... | 8 |
| 5.2 Individual visual alarm indication | 8 |
| 5.3 Connection of ancillary devices | 8 |
| 5.4 Manufacturer's adjustments | 8 |
| 5.5 On site adjustment of response behaviour | 8 |
| 5.6 Response to slowly developing fires..... | 9 |
| 5.7 Mechanical strength of the pipework..... | 9 |
| 5.8 Hardware components and additional sensing elements in the sampling device | 10 |
| 5.9 Airflow monitoring | 10 |
| 5.10 Power supply..... | 11 |
| 5.11 Data..... | 11 |
| 5.12 Additional requirements for software controlled detectors | 12 |
| 6 Tests..... | 13 |
| 6.1 General..... | 13 |
| 6.2 Repeatability..... | 16 |
| 6.3 Reproducibility | 17 |
| 6.4 Variation in supply parameters | 17 |
| 6.5 Dry heat (operational)..... | 18 |
| 6.6 Cold (operational) | 19 |
| 6.7 Damp heat, steady state (operational) | 20 |
| 6.8 Damp heat, steady state (endurance)..... | 21 |
| 6.9 Sulfur dioxide (SO ₂) corrosion (endurance) | 22 |
| 6.10 Shock (operational)..... | 23 |
| 6.11 Impact (operational)..... | 24 |
| 6.12 Vibration, sinusoidal (operational)..... | 25 |
| 6.13 Vibration, sinusoidal (endurance)..... | 26 |
| 6.14 Electromagnetic compatibility (EMC) immunity tests..... | 27 |
| 6.15 Fire sensitivity | 28 |
| 7 Classification and designation | 31 |
| 8 Marking | 32 |
| Annex A (informative) Apparatus for Response Threshold Value (RTV) measurements | 33 |
| Annex B (normative) Smouldering (pyrolysis) wood fire (TF2)..... | 41 |
| B.1 Fuel..... | 41 |
| B.2 Hotplate..... | 41 |
| B.3 Arrangement..... | 41 |
| B.4 Heating rate | 42 |
| B.5 End of test condition | 42 |
| B.6 Test validity criteria | 42 |
| Annex C (normative) Reduced smouldering pyrolysis wood fires (TF2A and TF2B)..... | 44 |
| C.1 Fuel..... | 44 |

| | | |
|---|---|-----------|
| C.2 | Hotplate..... | 44 |
| C.3 | Arrangement..... | 44 |
| C.4 | Heating rate | 45 |
| C.5 | End of test condition | 45 |
| C.6 | Test validity criteria | 45 |
| Annex D (normative) Glowing smouldering cotton fire (TF3) | | 47 |
| D.1 | Fuel..... | 47 |
| D.2 | Arrangement..... | 47 |
| D.3 | Ignition | 48 |
| D.4 | End of test condition | 48 |
| D.5 | Test validity criteria | 48 |
| Annex E (normative) Reduced glowing smouldering cotton fire (TF3A and TF3B)..... | | 50 |
| E.1 | Fuel..... | 50 |
| E.2 | Arrangement..... | 50 |
| E.3 | Ignition | 51 |
| E.4 | End of test condition | 51 |
| E.5 | Test validity criteria | 52 |
| Annex F (normative) Flaming plastics (polyurethane) fire (TF4) | | 53 |
| F.1 | Fuel..... | 53 |
| F.2 | Arrangement..... | 53 |
| F.3 | Ignition | 53 |
| F.4 | End of test condition | 53 |
| F.5 | Test validity criteria | 53 |
| Annex G (normative) Flaming liquid (n-heptane) fire (TF5) | | 55 |
| G.1 | Fuel..... | 55 |
| G.2 | Arrangement..... | 55 |
| G.3 | Ignition | 55 |
| G.4 | End of test condition | 55 |
| G.5 | Test validity criteria | 55 |
| Annex H (normative) Reduced flaming liquid (n-heptane) fire (TF5A and TF5B)..... | | 57 |
| H.1 | Fuel..... | 57 |
| H.2 | Arrangement..... | 57 |
| H.3 | Ignition | 57 |
| H.4 | End of test condition | 58 |
| H.5 | Test validity criteria | 58 |
| Annex I (normative) Fire test room and ventilation system | | 60 |
| I.1 | Fire test room | 60 |
| I.2 | Ventilation system | 62 |
| Annex J (informative) Information concerning the requirements for the response to slowly developing fires..... | | 64 |
| Annex K (informative) Apparatus for air flow monitoring test..... | | 68 |
| K.1 | General..... | 68 |
| K.2 | Airflow measuring with worst-case sampling device | 68 |
| K.3 | Airflow monitoring test with test pipe network..... | 69 |
| Annex ZA (informative) Clauses of this European Standard addressing the provisions of the EU Construction Products Directive | | 71 |
| ZA.1 | Scope and relevant clauses | 71 |
| ZA.2 | Procedures for the attestation of conformity of aspirating smoke detectors covered by this standard | 72 |
| ZA.3 | CE Marking and labelling and accompanying documentation | 77 |
| ZA.4 | EC certificate and declaration of conformity | 78 |
| Bibliography | | 80 |

Foreword

This document (EN 54-20:2006) has been prepared by Technical Committee CEN/TC 72 “Fire detection and fire alarm systems”, the secretariat of which is held by BSI.

This European Standard shall be given the status of a national standard, either by publication of an identical text or by endorsement, at the latest by December 2006, and conflicting national standards shall be withdrawn at the latest by June 2009.

This document has been prepared under a mandate given to CEN by the European Commission and the European Free Trade Association, and supports essential requirements of EU Directive(s).

For relationship with EU Directive(s), see informative Annex ZA, which is an integral part of this document.

EN 54 “Fire detection and fire alarm systems” consists of the following parts:

Part 1: Introduction

Part 2: Control and indicating equipment

Part 3: Fire alarm devices – Sounders

Part 4: Power supply equipment

Part 5: Heat detectors - Point detectors

Part 7: Smoke detectors - Point detectors using scattered light, transmitted light or ionization

Part 10: Flame detectors - Point detectors

Part 11: Manual call points

Part 12: Smoke detectors - Line detectors using an optical light beam

Part 13: Compatibility assessment of system components

Part 14: Guidelines for planning, design, installation, commissioning, use and maintenance

Part 15: Point detectors using a combination of detected fire phenomena

Part 16: Voice alarm control and indicating equipment

Part 17: Short-circuit isolators

Part 18: Input/output devices

Part 20: Aspirating smoke detectors

Part 21: Alarm transmission and fault warning routing equipment

Part 22: Line-type heat detectors

Part 23: Fire alarm devices - Visual alarms

Part 24: Components of voice alarm systems – Loudspeakers

Part 25: Components using radio links and system requirements

According to the CEN/CENELEC Internal Regulations, the national standards organizations of the following countries are bound to implement this European Standard: Austria, Belgium, Cyprus, Czech Republic, Denmark, Estonia, Finland, France, Germany, Greece, Hungary, Iceland, Ireland, Italy, Latvia, Lithuania, Luxembourg, Malta, Netherlands, Norway, Poland, Portugal, Romania, Slovakia, Slovenia, Spain, Sweden, Switzerland and United Kingdom.

1 Scope

This European Standard specifies the requirements, test methods and performance criteria for aspirating smoke detectors for use in fire detection and fire alarm systems installed in buildings.

Aspirating smoke detectors developed for the protection of specific risks that incorporate special characteristics (including additional features or enhanced functionality for which this standard does not define a test or assessment method) are not covered by this standard. The performance requirements for any special characteristics are beyond the scope of this standard.

NOTE Certain types of detector contain radioactive materials. The national requirements for radiation protection differ from country to country and they are not therefore specified in this standard.

2 Normative references

The following referenced documents are indispensable for the application of this document. For dated references, only the edition cited applies. For undated references, the latest edition of the referenced document (including any amendments) applies.

EN 54-1:1996, *Fire detection and fire alarm systems – Part 1: Introduction*

EN 54-2, *Fire detection and fire alarm systems – Part 2: Control and indicating equipment*

EN 54-4, *Fire detection and fire alarm systems – Part 4: Power supply equipment*

EN 54-7:2000, *Fire detection and fire alarm systems – Part 7: Smoke detectors – Point detectors using scattered light, transmitted light or ionization*

EN 50130-4:1995, *Alarm systems – Part 4: Electromagnetic compatibility – Product family standard: Immunity requirements for components of fire, intruder and social alarm systems*

EN 60068-1, *Environmental testing - Part 1: General and guidance (IEC 60068-1:1988 + Corrigendum 1988 + A1:1992)*

EN 60068-2-1, *Environmental testing; part 2: tests; tests A: cold (IEC 60068-2-1:1990)*

EN 60068-2-2, *Basic environmental testing procedures; part 2: tests; tests B: dry heat (IEC 60068-2-2:1974 + IEC 60068-2-2A:1976)*

EN 60068-2-6, *Environmental testing - Part 2: Tests - Tests Fc: Vibration (sinusoidal) (IEC 60068-2-6:1995 + Corrigendum 1995)*

EN 60068-2-27, *Basic environmental testing procedures – Part 2: Tests – Test Ea and guidance: Shock (IEC 60068-2-27:1987)*

EN 60068-2-42, *Environmental testing - Part 2-42: Tests; Test Kc: Sulphur dioxide test for contacts and connections (IEC 60068-2-42:2003)*

EN 60068-2-75, *Environmental testing - Part 2: Tests - Test Eh: Hammer tests (IEC 60068-2-75:1997)*

EN 60068-2-78, *Environmental testing - Part 2-78: Tests; Test Cab: Damp heat, steady state (IEC 60068-2-78:2001)*

EN 61386-1:2004, *Conduit systems for electrical installations - Part 1: General requirements (IEC 61386-1:1996 + A1:2000)*

3 Terms and definitions

For the purposes of this document the terms and definitions given in EN 54-1:1996 and the following apply.

3.1

aspirating smoke detector

smoke detector, in which air and aerosols are drawn through a sampling device and carried to one or more smoke sensing elements by an integral aspirator (e.g. fan or pump)

NOTE Each smoke sensing element may contain more than one sensor exposed to the same smoke sample.

3.2

sampling device

component or series of components or dedicated device (e.g. a pipe network, dedicated duct, probe or hood) which forms part of the ASD and transfers samples of air to the smoke sensing element(s)

NOTE The sampling device may be supplied separately.

3.3

sampling point

any point at which an air sample is drawn into the sampling device

3.4

response threshold value (RTV)

measure of the aerosol concentration in the proximity of the smoke sensing element at the moment that the specimen generates an alarm signal, when it is tested as described in 6.1.5

3.5

transport time

time for aerosols to transfer from a sampling point to the smoke sensing element

3.6

recovery

treatment of a specimen, after conditioning, so that the properties of the specimen may be stabilized before measurement of the said property as required by this standard

4 Symbols and abbreviations

For the purposes of this standard, the following abbreviations apply:

| | |
|-------------|-----------------------------------|
| ASD: | Aspirating smoke detector. |
| CIE: | Control and indicating equipment. |
| CPC: | Condensation particle counter. |
| DUT: | Detector under test. |
| EEA: | European Economic Area. |
| EMC: | Electromagnetic compatibility. |
| EOT: | End of test. |
| FPC: | Factory production control. |

MIC: Measuring ionization chamber.

RTV: Response threshold value.

5 Requirements

5.1 Compliance

To comply with this standard the detector shall meet the requirements of this clause, which shall be verified by inspection and engineering assessment, and, when tested in accordance with the tests described in Clause 6, shall meet the requirements of the tests.

5.2 Individual visual alarm indication

Each aspirating smoke detector shall be provided with integral red visual indicator(s), visible from outside the aspirating smoke detector, by which the individual smoke sensing element(s) (see 3.1), which released an alarm, can be identified, until the alarm condition is reset. Where other conditions of the detector may be visually indicated, they shall be clearly distinguishable from the alarm indication.

5.3 Connection of ancillary devices

The detector may provide for connections to ancillary devices (e.g. remote indicators, control relays), but open- or short-circuit failures of these connections shall not prevent the correct operation of the detector.

5.4 Manufacturer's adjustments

It shall not be possible to change the manufacturer's settings except by special means (e.g. the use of a special code or tool) or by breaking or removing a seal.

5.5 On site adjustment of response behaviour

NOTE 1 The effective response behaviour of an aspirating smoke detector is dependent upon both the sensitivity settings of the smoke sensing element and the design of the sampling device. Many types of aspirating smoke detectors therefore have facilities to adjust the smoke sensing element sensitivity to suit the application and sampling device etc.

If there is provision for field-adjustment of the sensitivity of the smoke sensing element then:

- a) access to the means of adjustment shall be limited by the need for the use of tools or a special code;
- b) it shall be possible to determine what sensitivity settings have been selected and to relate these to documentation which describes the sensitivity settings required for different sampling devices and applications;

NOTE 2 These adjustments may be made at the detector or at the control and indicating equipment.

NOTE 3 Changing sensitivity settings may affect the classification of the installed ASD – see Clause 7.

- c) if it is possible to configure the detector (including the sampling device and the sensitivity settings) in such a way that the detector does not comply with this standard, it shall be clearly marked on the detector or in the associated data that, if such configurations are used, the detector does not comply with this standard.

5.6 Response to slowly developing fires

The provision of "drift compensation" (e.g. to compensate for sensor drift due to the build up of dirt in the detector), and/or the provision of algorithms to match a detector to its environment, shall not lead to a significant reduction in the detector's sensitivity to slowly developing fires.

Because it is not practical to make tests with very slow increases in smoke density, an assessment of the detector's response to slow increases in smoke density shall be made by analysis of the circuit/software, and/or physical tests and simulations.

Where such algorithms are used, the detector shall be deemed to meet the requirements of this sub-clause if the documentation and assessment shows:

- a) how and why a sensor drifts,
- b) how the compensation technique modifies the detector response to compensate for the drift,
- c) that suitable limits to the compensation are in place to prevent the algorithms/means being applied outside the known limitations of the sensor and to ensure ongoing compliance with the clauses of this standard,
- d) for any rate of increase in smoke density R , which is greater than $A/4$ per hour (where A is the detector's initial uncompensated response threshold value), the time for the detector to give an alarm does not exceed $1,6 \times A/R$ by more than 100 s,
- e) the range of compensation is limited such that, throughout this range, the compensation does not cause the response threshold value of the detector to exceed its initial value by a factor greater than 1,6.

NOTE Further information about the assessment of requirements d) and e) is given in Annex J.

5.7 Mechanical strength of the pipework

The sampling pipes and fittings shall have adequate mechanical strength and temperature resistance.

The minimum requirement shall be:

To use pipes classified in accordance with EN 61386-1 to at least Class 1131 (for the first four digits, see Table 1).

Table 1 — Mechanical requirements of sampling pipe

| Property | Class | Severity |
|---------------------------|-------|-------------------------------|
| Resistance to compression | 1 | 125 N |
| Resistance to impact | 1 | 0,5 kg, 100 mm height to fall |
| Temperature range | 31 | -15 °C to +60 °C |

Pipes which are not so classified by the manufacturer of the pipe shall either be tested in accordance with Table 2 for the classes in Table 1, or the ASD manufacturer shall provide evidence that the requirements of this sub-clause are met.

Table 2 — Mechanical tests

| Test | EN 61386-1:2004, subclause |
|--------------------|----------------------------|
| Compression test | 10.2 |
| Impact test | 10.3 |
| Resistance to heat | 12.2 |

The impact test shall be conducted at the minimum of the temperature range (i.e. -15 °C).

The pipe is deemed to have passed the resistance to heat test if any crushing of the pipe does not reduce the internal diameter to less than 80 % of its original value.

Where the supplier of the ASD does not supply pipe for the sampling device, the product documentation shall specify that the requirements of this sub-clause shall be met.

NOTE An example of suitable evidence that the pipe meets this requirement is a test report, approval certificate or a declaration of conformity from the manufacturers of the pipe, even though it is not marked in accordance with EN 61386-1.

5.8 Hardware components and additional sensing elements in the sampling device

Components, including optional components (box, filter, sensor, valve etc.) in the sampling device shall be described in the documentation. The ASD, including the hardware components listed (i.e. the worst case combination in accordance with the manufacturer's documentation), shall meet the requirements of this standard.

If the component incorporates a sensing element which participates in the signal output of the ASD (e.g. for localisation information) then the performance of the ASD, including these sensing elements, shall meet the requirements of this standard.

5.9 Airflow monitoring

5.9.1 A fault signal shall be given when the airflow is outside the operational limits as specified by the manufacturer in his data.

5.9.2 The airflow through the aspirating smoke detector shall be monitored to detect leakage or obstruction of the sampling device or sampling point(s).

Either a fault signal shall be given when any leakage or obstruction results in an increase or decrease in the volumetric airflow of 20 % and greater through the aspirating smoke detector, or where the aspirating smoke detector incorporates technology which provides for constant (or near constant)

volumetric flow rate, which is largely independent of the sampling device (e.g. incorporates speed control of the fan or uses a positive displacement pump), then a fault signal shall be given when there is a loss of 50 % and greater of sampling points.

In both cases a period of 300 s is allowed between the fault being applied and the fault signal being given.

NOTE This time is independent of any delay times between signalling the fault and its indication at the CIE and is to allow for spurious short term flow variations which would otherwise result in unwanted fault signals.

5.9.3 Where an aspirating smoke detector has a facility to memorize the “normal” flow (present when the detector is installed or serviced) and thereafter monitor for deviations from this normal flow, the action of setting the memorized “normal” flow shall be a voluntary action under level 3 access (as defined in EN 54-2).

5.9.4 Power cycling the aspirating smoke detector (turning it off and on) shall not result in a change to the memorized normal flow.

5.10 Power supply

The power for the aspirating detector shall be supplied by a power supply complying with EN 54-4.

NOTE This power supply may be common to the control and indicating equipment.

5.11 Data

Aspirating smoke detectors shall either be supplied with sufficient technical, installation and maintenance data to enable their correct installation, sensitivity setting and operation or, if all of these data are not supplied with each ASD then reference to the appropriate data sheet(s) shall be given on, or with, each aspirating smoke detector.

The manufacturer shall declare in these data the classification of each sampling device configuration and associated sensitivity settings. If the number of configurations is undetermined, the manufacturer shall provide the necessary means to determine the classification of any used configuration.

These data shall be referred to in the test report to describe and determine the 'worst case' configuration(s) to be used in the fire tests (see 6.15) and the transport time for the sampling point(s) in the fire test room.

NOTE 1 The transport time should not include any processing time and is specifically limited to the time it takes to transport aerosols from the sampling point (in the fire test room) to the sensing element.

The method used for determining the classification shall be clearly stated.

NOTE 2 This is likely to take into account the following parameters:

- sizes and number of sampling points (maximum and minimum) and any limitations on their position along the sampling device,
- sensitivity settings for the detector and how this should be adjusted,
- details of permitted sampling device arrangement (e.g. single pipe, branch, H-configurations),
- maximum length of the sampling device (e.g. the maximum pipe length and branch length),
- aspirator setting (if adjustable).

5.12 Additional requirements for software controlled detectors

5.12.1 General

For detectors that rely on software control to fulfil the requirements of this standard, the requirements of 5.12.2, 5.12.3 and 5.12.4 shall be met.

5.12.2 Software documentation

5.12.2.1 The manufacturer shall submit documentation to the testing authority which gives an overview of the software design. This documentation shall be in sufficient detail for the design to be inspected for compliance with this standard and shall include at least the following:

- a) functional description of the main program flow (e.g. as a flow diagram or structogram) including:
 - 1) brief description of the modules and the functions that they perform,
 - 2) way in which the modules interact,
 - 3) overall hierarchy of the program,
 - 4) way in which the software interacts with the hardware of the detector,
 - 5) way in which the modules are called, including any interrupt processing;
- b) description of which areas of memory are used for the various purposes (e.g. the program, site specific data and running data);
- c) designation, by which the software and its version can be uniquely identified.

5.12.2.2 The manufacturer shall also have available detailed design documentation, which only needs to be provided if required by the testing authority. It shall comprise at least the following:

- a) overview of the whole system configuration, including all software and hardware components;
- b) description of each module of the program, containing at least:
 - 1) name of the module,
 - 2) description of the tasks performed,
 - 3) description of the interfaces, including the type of data transfer, the valid data range and the checking for valid data;
- c) full source code listings, as hard copy or in machine-readable form (e.g. ASCII-code), including global and local variables, constants and labels used, and sufficient comment for the program flow to be recognized;
- d) details of any software tools used in the design and implementation phase (e.g. CASE-Tools, Compilers)

5.12.3 Software design

To ensure the reliability of the detector, the following requirements for software design shall apply:

- a) software shall have a modular structure,

- b) design of the interfaces for manually and automatically generated data shall not permit invalid data to cause error in the program operation,
- c) software shall be designed to avoid the occurrence of deadlock of the program flow.

5.12.4 The storage of programs and data

The program necessary to comply with this European Standard and any pre-set data, such as manufacturer's settings, shall be held in non-volatile memory. Writing to areas of memory containing this program and data shall only be possible by the use of some special tool or code and shall not be possible during normal operation of the detector.

Site-specific data shall be held in memory which will retain data for at least two weeks without external power to the detector, unless provision is made for the automatic renewal of such data, following loss of power, within 1 h of power being restored.

6 Tests

6.1 General

6.1.1 Atmospheric conditions for tests

Unless otherwise stated in a test procedure, the testing shall be carried out after the test specimen has been allowed to stabilize in the standard atmospheric conditions for testing as described in EN 60068-1 as follows:

- a) temperature : (15 to 35) °C;
- b) relative humidity : (25 to 75) %;
- c) air pressure : (86 to 106) kPa.

If variations in these parameters have a significant effect on a measurement, then such variations shall be kept to a minimum during a series of measurements carried out as part of one test on one specimen.

6.1.2 Operating conditions for tests

If a test method requires a specimen to be operational, then the specimen shall be connected to supply and monitoring equipment with characteristics as required by the manufacturer's data. Unless otherwise specified in the test method, the supply parameters applied to the specimen shall be set within the manufacturer's specified range(s) and shall remain substantially constant throughout the tests. The value chosen for each parameter shall normally be the nominal value, or the mean of the specified range.

Where an aspirating smoke detector has multiple sensitivity settings, the sensitivity of the DUT during all tests in Table 3 (with the exception of the fire sensitivity test in 6.15) shall be set at the highest sensitivity setting used during the fire sensitivity test(s).

NOTE It is not intended that the environmental tests are conducted at all possible sensitivity settings, only at the highest used during the fire sensitivity test. This is particularly relevant where multiple classes and/or multiple configurations are submitted.

To allow the flow monitoring function to be checked as required before, during and/or after environmental tests, the sampling device may be simulated by a simpler sampling device (e.g. stub pipe with appropriate orifice(s)) to providing a typical airflow through the detector.

During the dry heat, damp heat and cold tests, a sufficient length of pipe shall be installed in the chamber to allow the temperature of the test aerosol entering the DUT to stabilize at the test temperature.

The details of the supply and monitoring equipment and the alarm criteria used shall be given in the test report.

6.1.3 Mounting arrangements

When necessary, the specimen shall be mounted by its normal means of attachment in accordance with the manufacturer's instructions. If these instructions describe more than one method of mounting then the method considered to be most unfavourable shall be chosen for each test.

6.1.4 Tolerances

Unless otherwise stated, the tolerances for the environmental test parameters shall be as given in the basic reference standards for the test (i.e. the relevant Parts of EN 60068-2 as listed in Clause 2).

If a specific tolerance or limit is not specified in a requirement or test procedure, then deviation limits of $\pm 5\%$ shall be applied.

6.1.5 Measurement of response threshold value

6.1.5.1 General

Because there are a number of different types of aspirating detectors available operating on quite different principles, which have very different ranges of sensitivity, various methods can be used to measure the response threshold value. The object of any method chosen shall be to determine a measure of the aerosol concentration, which when passing through the detector, just causes an alarm to be raised. This can generally be achieved by introducing smoke or an aerosol into the sampled air stream so that the detector is subjected to a slowly increasing concentration, and recording the concentration at the moment when an alarm is generated. Because the response threshold value is only used as a relative measurement, various parameters to measure the aerosol concentration may be used, providing that the chosen parameter is essentially proportional to the particle number concentration, for the particular test aerosol. For further information it is recommended to refer to Annex A.

6.1.5.2 Typical RTV measurement procedure

The specimen for which the response threshold value is to be measured shall be connected to measuring apparatus as recommended in Annex A. The airflow through the detector shall be controlled to a typical rate within the manufacturer's specification.

The DUT shall be connected to its supply and monitoring equipment as described in 6.1.2 and shall be allowed to stabilize for a period of at least 15 min unless otherwise specified by the manufacturer.

Before commencing each measurement the measuring apparatus and DUT shall be purged sufficiently to ensure that the new results are not affected by the previous measurement.

The aerosol concentration shall then be increased at an appropriate rate, depending upon the detector's sensitivity. The rate of increase in aerosol density shall be similar for all measurements on a particular detector type. It is recommended that the alarm signal is generated between 2 min and 10 min after the start of the measurement. Preliminary testing may be necessary to determine the appropriate rate for a particular detector type.

The response threshold value **N** shall be taken as the aerosol concentration at the moment when the detector gives the alarm signal. The particular measuring unit for the aerosol concentration depends on the measuring apparatus employed.

6.1.6 Test of the airflow monitoring facility

In accordance with the requirement in 5.9.2, when testing of the air flow monitoring facility is required it shall be tested as follows:

- a) where the volumetric flow is not maintained constant, the increase and decrease in flow shall be verified as follows:
 - 1) the normal volumetric airflow (e.g. litres/min) (F_n) shall be determined from the sampling configuration used for the fire tests using suitable instrumentation;
 - 2) the DUT shall be set up at a Test flow rate ($F_t = F_n \pm 10\%$) for testing the airflow monitoring. For a DUT that has a memorised normal flow the F_t shall be entered to the memory in accordance with the normal operating instructions for the DUT. This shall only be done once at the start of each environmental test and shall not be done during or after conditioning;
 - 3) for decreased flow the volumetric airflow is decreased from F_t by 20 % ($F_t - 20\%$);
 - 4) for increased flow the volumetric airflow is increased from F_t by 20 % ($F_t + 20\%$);

An example of a possible practical arrangement to achieve this test is given in Annex K.

- b) where the tests of a) cannot be applied (e.g. where the volumetric flow is maintained constant), the flow monitoring facility is to be verified by the loss of maximum of the 50 % of sampling points. The sampling points lost shall be those furthest from the sensing element on the worst case sampling device used in the fire sensitivity test(s). Loss of the points shall be separately tested for:
 - 1) total blockage of 50 % of the sampling points furthest from the sensing element; and
 - 2) breakage of the sampling device such that the same points are lost by breakage.

6.1.7 Provision for tests

Eight specimen aspirating detectors (or at least sufficient specimens to allow the reproducibility test to include eight smoke sensitive parts (see Table 3 notes) are required to conduct the tests as indicated in the test schedule, see 6.1.8, along with sufficient sampling pipes and fittings to set up the various sampling device configuration required by the tests.

The specimens submitted shall be representative of the manufacturer's normal production with regard to their construction and calibration.

NOTE This implies that the mean response threshold value of the eight specimens, found in the reproducibility test, should also represent the production mean, and that the limits specified in the reproducibility test should also be applicable to the manufacturer's production.

6.1.8 Test schedule

The specimens shall be tested according to the test schedule in Table 3. The specimens shall be numbered arbitrarily (with the exception of No. 8).

Table 3 — Test schedule

| Test | Clause | Specimen No(s) ^a |
|---|--------|-----------------------------|
| Repeatability | 6.2 | 1 |
| Reproducibility | 6.3 | 1 to 8 ^b |
| Variation of supply voltage | 6.4 | 1 |
| Dry heat (operational) | 6.5 | 1 |
| Cold (operational) | 6.6 | 1 |
| Damp heat, Steady State (operational) | 6.7 | 1 |
| Damp heat, Steady State (endurance) | 6.8 | 2 |
| SO ₂ corrosion (endurance) | 6.9 | 3 |
| Shock (operational) | 6.10 | 4 |
| Impact (operational) | 6.11 | 4 |
| Vibration (operational) | 6.12 | 5 |
| Vibration (endurance) | 6.13 | 5 |
| Electromagnetic compatibility, Immunity tests | 6.14 | 6 and 7 |
| Fire sensitivity | 6.15 | 8 |
| <p>^a The schedule shows the specimen numbers recommended for each test. Other arrangements may be used to improve the efficiency or cost of testing, or to reduce the number of specimens damaged by the testing. However, the reproducibility of the sensitivity of at least eight smoke sensitive parts shall be measured in the reproducibility test. If fewer specimens are to be used for the rest of the tests then the possible damaging effects of subjecting a specimen to a number of tests, especially endurance tests, have to be considered.</p> <p>^b The least sensitive specimen shall be designated specimen No 8 and used in the fire sensitivity tests.</p> | | |

6.2 Repeatability

6.2.1 Object

To show that the detector has stable behaviour with respect to its sensitivity even after a number of alarm conditions.

6.2.2 Test procedure

The response threshold value of the specimen to be tested shall be measured six times as described in 6.1.5.

The maximum and minimum of these six response threshold values shall be designated N_{\max} and N_{\min} respectively.

6.2.3 Requirements

The ratio of the response threshold values $N_{\max} : N_{\min}$ shall not be greater than 1,6.

6.3 Reproducibility

6.3.1 Object

To show that the sensitivity of the detector does not vary unduly from specimen to specimen.

6.3.2 Test procedure

The function of the airflow monitoring facility shall be checked, on each specimen, as described in 6.1.6.

The response threshold value of each of the test specimens shall be measured as described in 6.1.5.

The mean of these eight response threshold values shall be calculated and shall be designated N_{mean} .

The maximum and minimum of these eight response threshold values shall be designated N_{max} and N_{min} respectively.

6.3.3 Requirements

The correct fault signals, in accordance with 5.9, shall be given during the checks of the airflow monitoring facility.

The ratio of the response threshold values $N_{\text{max}} : N_{\text{mean}}$ shall not be greater than 1,33.

The ratio of the response threshold values $N_{\text{mean}} : N_{\text{min}}$ shall not be greater than 1,5.

6.4 Variation in supply parameters

6.4.1 Object

To show that within the specified range(s) of the supply parameters, (e.g. voltage), the sensitivity of the detector is not unduly dependent on these parameters.

This is either demonstrated by testing according to 6.4.2.1 or may be demonstrated by consideration of the electronic design of ASD and appropriate testing in accordance with 6.4.3.

6.4.2 Standard test procedure

6.4.2.1 Test procedure

The response threshold value of the specimen to be tested shall be measured as described in 6.1.5, and the function of the airflow monitoring facility shall be checked, as described in 6.1.6, under the nominal and extremes of the specified supply conditions (e.g. nominal, maximum and minimum supply voltage).

The maximum and minimum of the three response threshold values shall be designated N_{max} and N_{min} respectively.

6.4.2.2 Requirements

The correct fault signals, in accordance with 5.9, shall be given during the checks of the airflow monitoring facility.

The ratio of the response threshold values $N_{\text{max}} : N_{\text{min}}$ shall not be greater than 1,6.

6.4.3 Alternative test procedure

Where it can be shown by design examination that the sensitivity of the detector and speed of the airflow are independent of the supply voltage, then appropriate measurements (e.g. of internal voltages and flow rate) may be used to demonstrate that the detector meets this requirement.

6.5 Dry heat (operational)

6.5.1 Object

To demonstrate the ability of the detector to function correctly at high ambient temperature, that may occur for short periods in the service environment.

6.5.2 Test procedure

6.5.2.1 Reference

The test apparatus and procedure shall be as described in EN 60068-2-2, Test Bb, and as described in 6.5.2.2 to 6.5.2.7.

6.5.2.2 Initial measurements

Before conditioning, the response threshold value shall be measured as described in 6.1.5, with the temperature stabilising pipes installed as required in 6.5.2.5.

6.5.2.3 State of the specimen during conditioning

The specimen shall be mounted as described in 6.1.3 and shall be connected to its supply and monitoring equipment as described in 6.1.2.

6.5.2.4 Conditioning

The following conditioning shall be applied:

Temperature: $(+ 55 \pm 2) ^\circ\text{C}$,
Duration: 16 h.

6.5.2.5 Measurements during conditioning

The specimen shall be monitored during the transition to the conditioning temperature and during the conditioning period to detect any alarm or fault signals.

During the last hour of the conditioning period, the function of the airflow monitoring facility shall be checked as described in 6.1.6 and the response threshold value shall be measured as described in 6.1.5. For the RTV measurement, a sufficient length of pipe shall be installed in the chamber to allow the temperature of the test aerosol to stabilize at the test temperature before entering the detector.

It may also be necessary to have a length of pipe external to the chamber to transport the test aerosol from its source (e.g. a standard smoke tunnel). In this case the reference detector referred to in Figure A.4 is likely to be needed.

6.5.2.6 Final measurements

After a recovery period of at least 1 h at laboratory conditions, the function of the airflow monitoring facility shall be checked as described in 6.1.6 and the response threshold value shall be measured as described in 6.1.5.

6.5.2.7 Designation of measurements

The maximum and minimum of the three response threshold values measured in this test (i.e. before, during and after) shall be designated N_{\max} and N_{\min} respectively.

6.5.3 Requirements

No alarm or fault signals shall be given during the period that the temperature is increasing to the conditioning temperature or during the conditioning period, except as required by the tests in the last hour.

The correct fault signals, in accordance with 5.9, shall be given during the checks of the airflow monitoring facility.

The ratio of the response threshold values $N_{\max} : N_{\min}$ shall not be greater than 1,6.

6.6 Cold (operational)

6.6.1 Object

To demonstrate the ability of the detector to function correctly at low ambient temperatures appropriate to the anticipated service environment.

6.6.2 Test procedure

6.6.2.1 Reference

The test apparatus and procedure shall be as described in EN 60068-2-1, Test Ab and as described in 6.6.2.2 to 6.6.2.6.

6.6.2.2 Initial measurements

Before conditioning, the response threshold value shall be measured as described in 6.1.5, with the temperature stabilising pipes installed as required in 6.5.2.5.

6.6.2.3 State of the specimen during conditioning

The specimen shall be mounted as described in 6.1.3 and shall be connected to its supply and monitoring equipment as described in 6.1.2.

6.6.2.4 Conditioning

The following conditioning shall be applied:

Temperature: $(-10 \pm 3) ^\circ\text{C}$,
Duration: 16 h.

If the detector cannot operate at less than $0 ^\circ\text{C}$, then:

- a) the cold test shall be conducted at $(+5 \pm 3) ^\circ\text{C}$;
- b) the detector shall give a fault warning if the temperature falls below $0 ^\circ\text{C}$. This shall be checked by reducing the temperature to $(-5 \pm 3) ^\circ\text{C}$; and
- c) the manufacturer's information shall clearly state that the detector will not operate below $0 ^\circ\text{C}$ and that special precautions have to be taken against the temperature falling below $0 ^\circ\text{C}$.

6.6.2.5 Measurements during conditioning

The specimen shall be monitored during transition to the conditioning temperature and during the conditioning period to detect any alarm or fault signals.

During the last hour of the conditioning period, the function of the airflow monitoring facility shall be checked as described in 6.1.6 and the response threshold value shall be measured as described in 6.1.5. For the RTV measurement, a sufficient length of pipe shall be installed in the chamber to allow the temperature of the test aerosol to stabilize at the test temperature before entering the detector.

6.6.2.6 Final measurements

After a recovery period of at least 1 h at laboratory conditions, the function of the airflow monitoring facility shall be checked as described in 6.1.6 and the response threshold value shall be measured as described in 6.1.5.

The maximum and minimum of the response threshold values measured in this test shall be designated N_{\max} and N_{\min} respectively.

6.6.3 Requirements

No alarm or fault signals shall be given during the period in which the temperature is decreasing to the conditioning temperature or during the conditioning period, except as required by the tests in the last hour.

The correct fault signals, in accordance with 5.9, shall be given during the checks of the airflow monitoring facility.

The ratio of the response threshold values $N_{\max} : N_{\min}$ shall not be greater than 1,6.

6.7 Damp heat, steady state (operational)

6.7.1 Object

To demonstrate the ability of the detector to function correctly at high relative humidity (without condensation), which may occur for short periods in the anticipated service environment.

6.7.2 Test procedure

6.7.2.1 Reference

The test apparatus and procedure shall be as described in EN 60068-2-78, Test Cab and as described in 6.7.2.2 to 6.7.2.6.

6.7.2.2 Initial measurements

Before conditioning, the response threshold value shall be measured as described in 6.1.5, with the temperature stabilising pipes installed as required in 6.7.2.5.

6.7.2.3 State of the specimen during conditioning

The specimen shall be mounted as described in 6.1.3 and shall be connected to its supply and monitoring equipment as described in 6.1.2.

6.7.2.4 Conditioning

The following conditioning shall be applied:

| | |
|--------------------|--------------|
| Temperature: | (40 ± 2) °C, |
| Relative humidity: | (93 ± 3) %, |
| Duration: | 4 days. |

6.7.2.5 Measurements during conditioning

The specimen shall be monitored during the transition to the conditioning temperature and during the conditioning period to detect any alarm or fault signals.

During the last hour of the conditioning period, the function of the airflow monitoring facility shall be checked as described in 6.1.6 and the response threshold value shall be measured as described in 6.1.5. For the RTV measurement, a sufficient length of pipe shall be installed in the chamber to allow the temperature of the test aerosol to stabilize at the test temperature before entering the detector.

NOTE For practical reasons, it is accepted that the test aerosol will not be at the same relative humidity as the conditioning environment.

6.7.2.6 Final measurements

After a recovery period of at least 1 h at laboratory conditions, the function of the airflow monitoring facility shall be checked as described in 6.1.6 and the response threshold value shall be measured as described in 6.1.5.

The maximum and minimum of the response threshold values measured in this test shall be designated N_{\max} and N_{\min} respectively.

6.7.3 Requirements

No alarm or fault signals shall be given during the period that the temperature is increasing to the conditioning temperature or during the conditioning period, except as required by the tests in the last hour.

The correct fault signals, in accordance with 5.9, shall be given during the checks of the airflow monitoring facility.

The ratio of the response threshold values $N_{\max} : N_{\min}$ shall not be greater than 1,6.

6.8 Damp heat, steady state (endurance)

6.8.1 Object

To demonstrate the ability of the detector to withstand the long term effects of humidity in the service environment (e.g. changes in electrical properties of materials, chemical reactions involving moisture, galvanic corrosion).

6.8.2 Test procedure

6.8.2.1 Reference

The test apparatus and procedure shall be as described in EN 60068-2-78, Test Cab , and as described in 6.8.2.2 to 6.8.2.5.

6.8.2.2 Initial measurements

Before conditioning, the response threshold value shall be measured as described in 6.1.5.

6.8.2.3 State of the specimen during conditioning

The specimen shall be mounted as described in 6.1.3 but shall not be supplied with power during the conditioning.

6.8.2.4 Conditioning

The following conditioning shall be applied:

| | |
|--------------------|-------------------------------|
| Temperature: | $(40 \pm 2) ^\circ\text{C}$, |
| Relative humidity: | $(93 \pm 3) \%$, |
| Duration: | 21 days. |

6.8.2.5 Final measurements

After a recovery period of at least 1 h at laboratory conditions, the function of the airflow monitoring facility shall be checked as described in 6.1.6 and the response threshold value shall be measured as described in 6.1.5.

The maximum and minimum of the response threshold values measured in this test shall be designated N_{\max} and N_{\min} respectively.

6.8.3 Requirements

The correct fault signals, in accordance with 5.9, shall be given during the checks of the airflow monitoring facility.

The ratio of the response threshold values $N_{\max} : N_{\min}$ shall not be greater than 1,6.

6.9 Sulfer dioxide (SO₂) corrosion (endurance)

6.9.1 Object

To demonstrate the ability of the detector to withstand the corrosive effects of sulfur dioxide as an atmospheric pollutant.

6.9.2 Test procedure

6.9.2.1 Reference

The test apparatus and procedure shall be as described in EN 60068-2-42, Test Kc, except that the conditioning shall be as described in 6.9.2.4.

6.9.2.2 Initial measurements

Before conditioning, the response threshold value shall be measured as described in 6.1.5.

6.9.2.3 State of the specimen during conditioning

The specimen shall be mounted as described in 6.1.3. It shall not be supplied with power during the conditioning, but it may have untinned copper wires, of the appropriate diameter, connected to

sufficient terminals, to allow the final measurement to be made, without making further connections to the specimen.

6.9.2.4 Conditioning

The following conditioning shall be applied:

| | |
|--------------------------------|------------------------------------|
| Temperature: | $(25 \pm 2) ^\circ\text{C}$, |
| Relative humidity: | $(93 \pm 3) \%$ (no condensation), |
| SO ₂ concentration: | (25 ± 5) ppm (by volume), |
| Duration: | 21 days. |

6.9.2.5 Final measurements

Immediately after the conditioning, the specimen shall be subjected to a drying period of 16 h at $(40 \pm 2) ^\circ\text{C}$, $\leq 50 \%$ RH, followed by a recovery period of at least 1 h at laboratory conditions. After this recovery period the function of the airflow monitoring facility shall be checked as described in 6.1.6, and the response threshold value shall be measured as described in 6.1.5.

The maximum and minimum of the response threshold values measured in this test shall be designated N_{\max} and N_{\min} respectively.

6.9.3 Requirements

The correct fault signals, in accordance with 5.9, shall be given during the checks of the airflow monitoring facility.

The ratio of the response threshold values $N_{\max} : N_{\min}$ shall not be greater than 1,6.

6.10 Shock (operational)

6.10.1 Object

To demonstrate the immunity of the detector to mechanical shocks, which are likely to occur, albeit infrequently, in the anticipated service environment.

6.10.2 Test procedure

6.10.2.1 Reference

The test apparatus and procedure shall be as described in EN 60068-2-27, Test Ea, except that the conditioning shall be as described in 6.10.2.4.

6.10.2.2 Initial measurements

Before conditioning, the response threshold value shall be measured as described in 6.1.5.

6.10.2.3 State of the specimen during conditioning

The specimen shall be mounted as described in 6.1.3 to a rigid fixture, and shall be connected to its supply and monitoring equipment as described in 6.1.2.

6.10.2.4 Conditioning

For specimens with a mass $\leq 4,75$ kg the following conditioning shall be applied:

| | |
|-----------------------|--|
| Shock pulse type: | Half sine, |
| Pulse duration: | 6 ms, |
| Peak acceleration: | $10 \times (100 - 20M) \text{ m s}^{-2}$ (where M is the specimen's mass in kg), |
| Number of directions: | 6, |
| Pulses per direction: | 3. |

No test is applied to specimens with a mass $> 4,75$ kg.

6.10.2.5 Measurements during conditioning

The specimen shall be monitored during the conditioning period to detect any alarm or fault signals.

6.10.2.6 Final measurements

After the conditioning, the function of the airflow monitoring facility shall be checked as described in 6.1.6 and the response threshold value shall be measured as described in 6.1.5.

The maximum and minimum of the response threshold values measured in this test shall be designated N_{\max} and N_{\min} respectively.

6.10.3 Requirements

No alarm or fault signals shall be given during the conditioning.

The correct fault signals, in accordance with 5.9, shall be given during the checks of the airflow monitoring facility.

The ratio of the response threshold values $N_{\max} : N_{\min}$ shall not be greater than 1,6.

6.11 Impact (operational)

6.11.1 Object

To demonstrate the immunity of the detector to mechanical impacts upon its surface, which it may sustain in the normal service environment, and which it can reasonably be expected to withstand.

6.11.2 Test procedure

6.11.2.1 Reference

The test apparatus and procedure shall be as described in EN 60068-2-75, Test Ehb.

6.11.2.2 Initial measurements

Before conditioning, the response threshold value shall be measured as described in 6.1.5.

6.11.2.3 State of the specimen during conditioning

The specimen shall be mounted as described in 6.1.3 to a rigid structure, as required by EN 60068-2-75, and shall be connected to its supply and monitoring equipment as described in 6.1.2.

6.11.2.4 Conditioning

Impacts shall be applied to all accessible surfaces of the specimen. For all such surfaces three blows shall be applied to any point(s) considered likely to cause damage to or impair the operation of the specimen.

Care shall be taken to ensure that the results from a series of three blows do not influence subsequent series. In case of doubts, the defect shall be disregarded and a further three blows shall be applied to the same position on a new specimen.

The following conditioning shall be applied:

| | |
|------------------------------|-----------------|
| Impact energy: | (0,5 ± 0,04) J, |
| Number of impacts per point: | 3. |

6.11.2.5 Measurements during conditioning

The specimen shall be monitored during the conditioning period to detect any alarm or fault signals.

6.11.2.6 Final measurements

After the conditioning, the function of the airflow monitoring facility shall be checked as described in 6.1.6, and the response threshold value shall be measured as described in 6.1.5.

The maximum and minimum of the response threshold values measured in this test shall be designated N_{max} and N_{min} respectively.

6.11.3 Requirements

No alarm or fault signals shall be given during the conditioning.

The correct fault signals, in accordance with 5.9, shall be given during the checks of the airflow monitoring facility.

The ratio of the response threshold values $N_{max} : N_{min}$ shall not be greater than 1,6.

6.12 Vibration, sinusoidal (operational)

6.12.1 Object

To demonstrate the immunity of the detector to vibration at levels considered appropriate to the normal service environment.

6.12.2 Test procedure

6.12.2.1 Reference

The test apparatus and procedure shall be as described in EN 60068-2-6, Test Fc, and as described in 6.12.2.2 to 6.12.2.6.

6.12.2.2 Initial measurements

Before conditioning, the response threshold value shall be measured as described in 6.1.5.

6.12.2.3 State of the specimen during conditioning

The specimen shall be mounted on a rigid fixture as described in 6.1.3 and shall be connected to its supply and monitoring equipment as described in 6.1.2.

The vibration shall be applied in each of three mutually perpendicular axes, in turn, the specimen shall be mounted so that one of the three axes is perpendicular to its normal mounting plane.

6.12.2.4 Conditioning

The following conditioning shall be applied:

| | |
|-------------------------|---|
| Frequency range: | (10 to 150) Hz, |
| Acceleration amplitude: | 5 m s ⁻² (\approx 0,5 g _n), |
| Number of axes: | 3, |
| Sweep rate: | 1 octave min ⁻¹ , |
| Number of sweep cycles: | 1 per axis. |

NOTE The vibration operational and endurance tests may be combined such that the specimen is subjected to the operational test conditioning followed by the endurance test conditioning in one axis before changing to the next axis. Only one initial and one final measurement need then be made.

6.12.2.5 Measurements during conditioning

The specimen shall be monitored during the conditioning period to detect any alarm or fault signals.

6.12.2.6 Final measurements

After the conditioning, the function of the airflow monitoring facility shall be checked as described in 6.1.6, and the response threshold value shall be measured as described in 6.1.5.

The maximum and minimum of the response threshold values measured in this test shall be designated N_{\max} and N_{\min} respectively.

6.12.3 Requirements

No alarm or fault signals shall be given during the conditioning.

The correct fault signals, in accordance with 5.9, shall be given during the checks of the airflow monitoring facility.

The ratio of the response threshold values $N_{\max} : N_{\min}$ shall not be greater than 1,6.

6.13 Vibration, sinusoidal (endurance)

6.13.1 Object

To demonstrate the ability of the detector to withstand the long term effects of vibration at levels appropriate to the service environment.

6.13.2 Test procedure

6.13.2.1 Reference

The test apparatus and procedure shall be as described in EN 60068-2-6, Test Fc, and as described in 6.13.2.2 to 6.13.2.5.

6.13.2.2 Initial measurements

Before conditioning, the response threshold value shall be measured as described in 6.1.5.

6.13.2.3 State of the specimen during conditioning

The specimen shall be mounted on a rigid fixture as described in 6.1.3, but shall not be supplied with power during conditioning.

The vibration shall be applied to each of three mutually perpendicular axes in turn. The specimen shall be mounted so that one of the three axes is perpendicular to its normal mounting axis.

6.13.2.4 Conditioning

The following conditioning shall be applied:

| | |
|-------------------------|--|
| Frequency range: | (10 to 150) Hz, |
| Acceleration amplitude: | 10 m s ⁻² (≈1,0 g _n), |
| Number of axes: | 3, |
| Sweep rate: | 1 octave min ⁻¹ , |
| Number of sweep cycles: | 20 per axis. |

NOTE The vibration operational and endurance tests may be combined such that the specimen is subjected to the operational test conditioning followed by the endurance test conditioning in one axis before changing to the next axis. Only one initial and one final measurement need then be made.

6.13.2.5 Final measurements

After the conditioning, the function of the airflow monitoring facility shall be checked as described in 6.1.6, and the response threshold value shall be measured as described in 6.1.5.

The maximum and minimum of the response threshold values measured in this test shall be designated **N_{max}** and **N_{min}** respectively.

6.13.3 Requirements

The correct fault signals, in accordance with 5.9, shall be given during the checks of the airflow monitoring facility.

The ratio of the response threshold values **N_{max} : N_{min}** shall not be greater than 1,6.

6.14 Electromagnetic compatibility (EMC) immunity tests

EMC immunity tests shall be carried out as described in EN 50130-4:1995. This will mean conducting the following tests:

- 1) mains supply voltage variations¹⁾ – if the aspirating detector incorporates a mains supply,
- 2) mains supply voltage dips and short interruptions – if the aspirating detector incorporates a mains supply,
- 3) electrostatic discharge,

1) The mains supply voltage variations test can be combined with the variation in supply parameters test (see 6.4).

- 4) radiated electromagnetic fields,
- 5) conducted disturbances induced by electromagnetic fields,
- 6) fast transient bursts,
- 7) slow high energy surges.

For these tests the following shall apply:

- a) the functional test, called for in the initial and final measurements, shall be a check of the airflow monitoring facility as described in 6.1.6 and a measurement of the response threshold value as described in 6.1.5;
- b) the required operating condition shall be as described in 6.1.2;
- c) the acceptance criteria for the functional test after the conditioning shall be that the correct fault signals, in accordance with 5.9, shall be given during the checks of the airflow monitoring facility, and the ratio of the response threshold values $N_{\max} : N_{\min}$ shall not be greater than 1,6, where N_{\max} and N_{\min} are respectively the maximum and minimum of the response threshold values measured in the initial and final measurements.

6.15 Fire sensitivity

6.15.1 Object

To show that the detector has adequate sensitivity to a broad spectrum of smoke types as required for general application in fire detection systems for buildings and other applications as applicable to the class of detector.

6.15.2 Principle

The detector is exposed to a series of test fires with a sampling device suitable for room protection and incorporating the "worst case" arrangement with respect to dilution and transport times, all in accordance with the manufacturer's recommendations. The test fires are those used for assessing point smoke detectors and the number of sampling points in the fire test room shall be that recommended by the manufacturer to cover the same area as a point smoke detector. Sample points not in the fire test room shall draw in clean air during the tests.

6.15.3 Test procedure

6.15.3.1 Fire test room

The fire sensitivity tests shall be conducted in a rectangular room with a flat horizontal ceiling, and the following dimensions:

Length: 9 m to 11 m,
Width: 6 m to 8 m,
Height: 3,8 m to 4,2 m.

The fire test room shall be equipped with the following measuring instruments as indicated in Annex I:

Measuring ionization chamber (MIC),
Obscuration meter.

6.15.3.2 Test fires

The specimens shall be subjected to test fires (as defined in Annexes B to H) in accordance with Table 4.

Table 4 — Fire test requirements for multi-class detectors

| Detector Class | Combination of configurations | Configuration to be used | Test fires to be applied (see Annexes B to H) |
|---|--------------------------------|--------------------------|---|
| A only | Config A | Config A | TF2A, TF3A, TF4, TF5A |
| B only | Config B | Config B | TF2B, TF3B, TF4, TF5B |
| C only | Config C | Config C | TF2, TF3, TF4, TF5 |
| B and C | Config B = Config C | Config B/C | TF2B, TF3B, TF4, TF5B |
| B and C | Config B ≠ Config C | Config B | TF2B, TF3B, TF5B |
| | | Config C | TF2, TF3, TF4, TF5 |
| A, B and C | Config A = Config B = Config C | Config A/B/C | TF2A, TF3A, TF4, TF5A |
| A, B and C | Config A = Config B ≠ Config C | Config A/B | TF2A, TF3A, TF4, TF5A |
| | | Config C | TF2, TF3, TF4, TF5 |
| A, B and C | Config A ≠ Config B = Config C | Config A | TF2A, TF3A, TF5A |
| | | Config B/C | TF2B, TF3B, TF4, TF5B |
| A, B and C | Config A ≠ Config B ≠ Config C | Config A | TF2A, TF3A, TF5A |
| | | Config B | TF2B, TF3B, TF5B |
| | | Config C | TF2, TF3, TF4, TF5 |
| <p>NOTE</p> <p>“Config A” means the worst case configuration for the Class A testing;</p> <p>“Config B” means the worst case configuration for the Class B testing;</p> <p>“Config C” means the worst case configuration for the Class C testing;</p> <p>“=” means that configurations are the same (e.g. Config A = Config B means that the same configuration is used for the Class A testing as for the Class B testing);</p> <p>“≠” means that configurations are different (e.g. Config B ≠ Config C means that a different configuration is used for the Class B testing than for the Class C testing).</p> | | | |

The type, quantity and arrangement of the fuel and the method of ignition are described in Annexes B to H for each test fire, along with the end of test conditions and the required profile curve limits. For convenience the EOT conditions are summarized in Table 5:

To be a valid test fire, the development of the fire shall be such that the profile curves. Specifically m against time and m against y (when specified), fall within the specified limits, up to the time when all of the specimens have generated an alarm signal or the end of test condition is reached, whichever is the earlier. If these conditions are not met then the test is invalid and shall be repeated. It is permissible, and may be necessary, to adjust the quantity, condition (e.g. moisture content) and arrangement of the fuel to obtain valid test fires.

Table 5 — Summary of End-of-Test obscuration (m) values for the test fires (units dB m⁻¹)

| | Class A | Class B | Class C |
|-----|---------|---------|------------------------------------|
| TF2 | 0,05 | 0,15 | 2 |
| TF3 | 0,05 | 0,15 | 2 |
| TF4 | n/a | N/a | 1,27<EOT<1,73 (actually, y=6) |
| TF5 | 0,1 | 0,3 | 0,92< EOT< 1,24 (actually, y=6) |

6.15.3.3 Mounting of the specimens

The design of the sampling device shall incorporate the "worst case" allowable with respect to the dilution (i.e. the maximum number of sampling points) and transport time (i.e. maximum pipe lengths). This sampling pipe network shall be installed with the worst case sampling point (s) exposed to the test fires. The number of sampling point(s) in the fire test room shall not exceed the minimum number of points that the manufacturer recommends to cover the same area as a point smoke detector. The sampling points in the fire test room shall be mounted in the designated area as defined in the respective annexes and shall be the "worst case" sampling points with respect to the system performance in the tests which may be those points with the longest transport time or those points with the lowest effective sensitivity. The rest of the sampling points shall be arranged outside the fire test room and shall draw in clean air during the tests.

6.15.3.4 Initial conditions

Before each test fire the room shall be ventilated with clean air until it is free from smoke, so that the conditions listed below can be obtained.

The ventilation system shall be switched off and all doors, windows and other openings shall be closed. The air in the room shall then be allowed to stabilize, and the following conditions shall be obtained before the test is started:

| | |
|-----------------------------|---|
| Air temperature T : | $(23 \begin{smallmatrix} +5 \\ -3 \end{smallmatrix})$ °C, |
| Air movement: | Negligible or stable where the re-circulation fan is operational, |
| Smoke density (ionization): | $y \leq 0,05$, |
| Smoke density (optical): | $m \leq 0,02$ dB m ⁻¹ . |

NOTE The stability of the air and temperature affects the smoke flow within the room. This is particularly important for the test fires which produce low thermal lift for the smoke (e.g. TF2 and TF3). It is therefore recommended that the difference between the temperature near the floor and the ceiling is < 2 °CC, and that local heat sources that can cause convection currents (e.g. lights and heaters) should be avoided. If it is necessary for people to be in the room at the beginning of the test fire they should leave as soon as possible, taking care to produce the minimum disturbance to the air.

6.15.3.5 Recording of fire parameters and response values

During each fire test the fire parameters in Table 6 shall be recorded continuously or at least once per second.

The alarm signal given by the ASD shall be monitored such that the time of response for the ASD to each test fire shall be recorded along with the fire parameters y_a and m_a at the moment of response.

Table 6 — Parameters to be recorded during test fires

| Parameter | Symbol | Units |
|----------------------------|------------|--------------------|
| Temperature change | ΔT | K |
| Smoke density (ionisation) | Y | Dimensionless |
| Smoke density (optical) | M | dB m ⁻¹ |

6.15.4 Requirements

The aspirating smoke detector shall generate an alarm signal, in each test fire, before a time T_i after the specified end of test condition is reached where the correction time T_i is the transport time for the sampling point(s) in the fire test room up to a maximum of 60 s.

7 Classification and designation

Due to the inherent flexibility in the design of sampling devices, aspirating smoke detectors are generally intended for use in many varied and often rather specialized applications. Therefore it is not possible to conduct type tests that define acceptance criteria for all of these applications. However, in recognition of the diversity of application three classes are defined to enable system designers and installers to select the most appropriate sensitivity.

The manufacturer shall clearly state, in the data presented in 5.11, to which class or classes the aspirating smoke detector is designed. To demonstrate compliance with a specific class the aspirating smoke detector shall be subjected to appropriate fire sensitivity test as defined in 6.15.

Table 7 provides a summary of the various classes of detector and the corresponding fire tests used for the classification.

Table 7 — Classification table for aspirating smoke detectors

| Class | Description | Example application(s) | Requirement |
|-------|---|--|--|
| A | Aspirating smoke detector providing very high sensitivity | Very early detection: the detection of very dilute smoke for example entering air conditioning ducts to detect the extremely dilute concentrations of smoke that might emanate from equipment in the environmentally controlled area such as a clean room. | Passes test fires TF2A, TF3A, TF4 and TF5A |
| B | Aspirating smoke detector providing enhanced sensitivity | Early detection: for example special fire detection within or close to particularly valuable, vulnerable or critical items such as computer or electronic equipment cabinets. | Passes test fires TF2B, TF3B, TF4 and TF5B |
| C | Aspirating smoke detector providing normal sensitivity | Standard detection: general fire detection in normal rooms or spaces, giving, for example, at least an equivalent level of detection as a point or beam type smoke detection system. | Passes test fires TF2, TF3, TF4 and TF5 |

8 Marking

Each detector shall be clearly marked with the following information:

- a) number of this standard and the class(es) to which it conforms,
- b) name or trademark of the manufacturer or supplier,
- c) model designation (type or number),
- d) wiring terminal designations,
- e) some mark(s) or code(s) (e.g. a serial No. or batch code), by which the manufacturer can identify, at least, the date or batch and place of manufacture, and the version number(s) of any software, contained within the detector.

Where any marking on the device uses symbols or abbreviations not in common use, these shall be explained in the data supplied with the device.

The marking shall be visible during installation and shall be accessible during maintenance.

The markings shall not be placed on screws or other easily removable parts.

Annex A (informative)

Apparatus for Response Threshold Value (RTV) measurements

To measure the response threshold value of an aspirating smoke detector, it is essential to be able to generate an aerosol in a precisely controlled manner so that the detector can be subjected to sampled air with a slowly and consistently increasing aerosol concentration, and to be able to obtain a measure of the concentration which is essentially proportional to the particle number concentration.

To test the wide range of types and classes of aspirating detectors, either it should be possible to adjust the test apparatus to give a wide range of airflow rates and aerosol concentrations, or different sets of test apparatus should be utilized to suit the various types and classes of ASD.

It is essential that the test apparatus used is capable of generating repeatable results.

The following three examples are provided for the guidance of the test houses. All three consist of four main functional blocks: aerosol generation, aerosol dilution, aerosol measurement and the DUT (see Figure A.1).

Measurement of the aerosol concentration entering the DUT is not mandatory but is recommended.

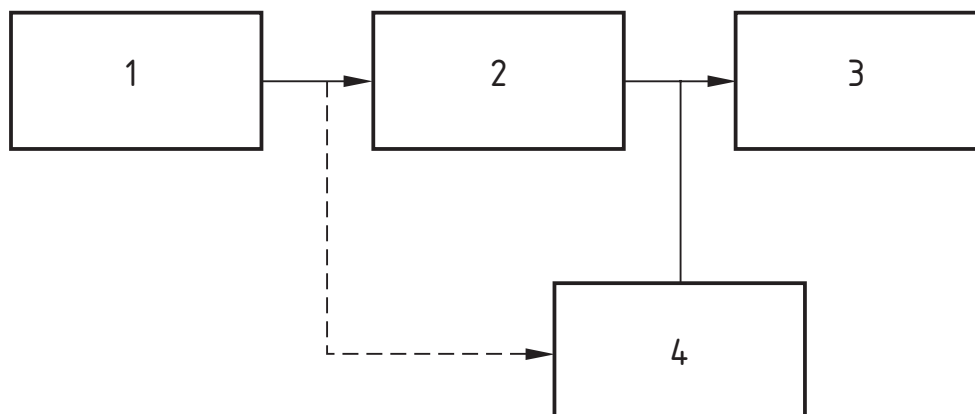

Key

- 1 aerosol generator
- 2 dilution stage
- 3 DUT
- 4 aerosol measurement

Figure A.1 — Functional block diagram for measuring RTV

RTV measurement apparatus – Example 1

The apparatus described below allows wide adjustment of the aerosol concentration and direct measurement of the concentration entering the DUT. As such it is particularly suited to generating and measuring the low aerosol concentrations needed for testing the more sensitive aspirating smoke detectors.

The apparatus uses compressed air to provide a highly controlled dilution stage and a Condensation Particle Counter (CPC) to directly measure the very low concentration of aerosol entering the DUT (see Figure A.2).

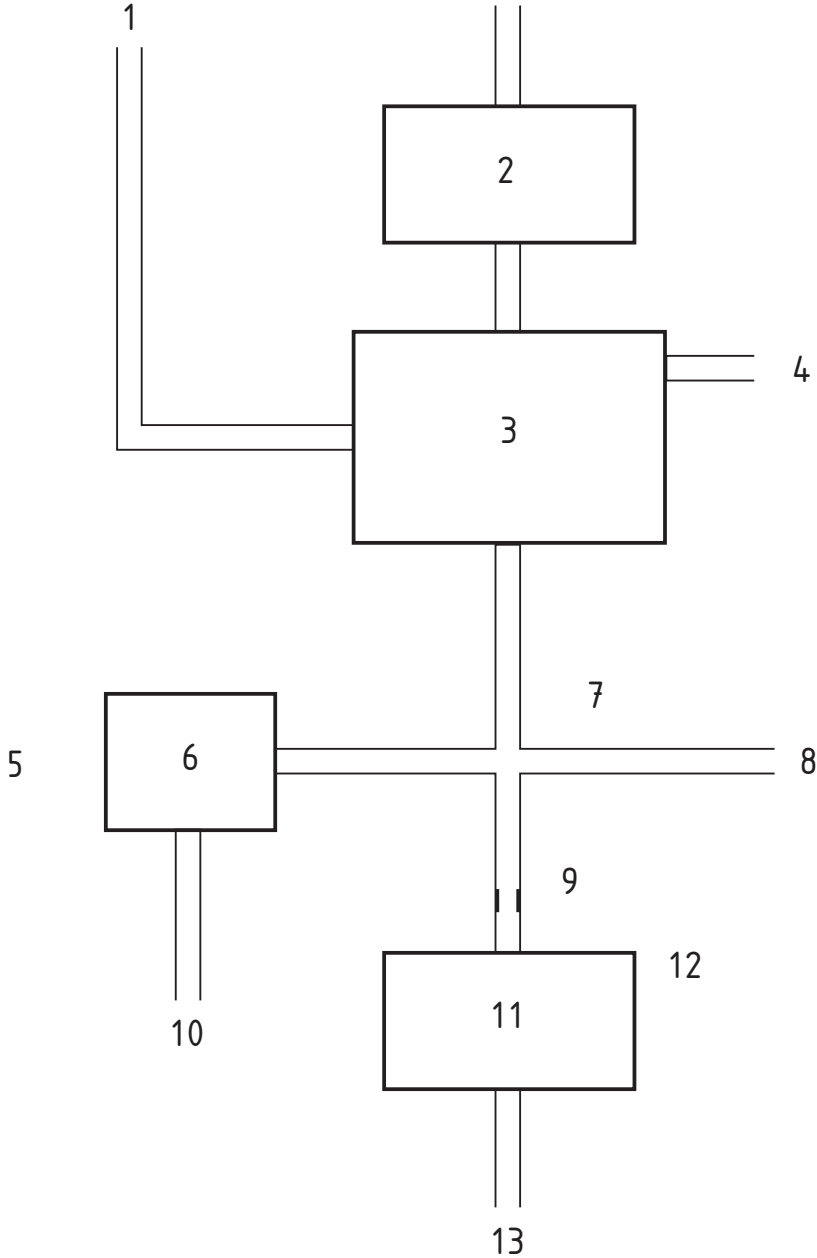

- Key**
- 1 compressed air supply
 - 2 aerosol generator
 - 3 controllable aerosol dilution
 - 4 aerosol waste
 - 5 aerosol measurement
 - 6 CPC
 - 7 junction
 - 8 vent
 - 9 restriction
 - 10 CPC Exhaust
 - 11 DUT
 - 12 aspirating detector under test
 - 13 detector exhaust

Figure A.2 — Block diagram of the apparatus Example 1 for measuring RTV

The aerosol generator generates a polydisperse paraffin mist as specified in EN 54-7:2000, Annex B. The aerosol passes into a dilution system where it is mixed with clean air in a manner which allows precisely adjustable dilution. The diluted aerosol is then presented to the aspirating detector under test (DUT) and a condensation particle counter (CPC), which measures the aerosol at the same concentration as that entering the DUT. The flow rate through the aerosol generator/dilution system is set so that it just exceeds the sum of the flows required by the DUT and the CPC with the excess flowing out of the vent **8** (see Figure A.2) This allows the DUT and CPC to draw the aerosol from the same point which is at approximately atmospheric pressure. Both the CPC and the DUT operate with their own aspirating pumps. The restriction **9** is added to simulate the pressure drop of the sampling pipe system and to allow the flow through the DUT to be within the manufacturer's specifications. The distances from junction **7** to the CPC and the DUT should be short, so that the CPC and DUT effectively measure the same aerosol density at the same time.

Figure A.3 shows further details of a suitable test apparatus.

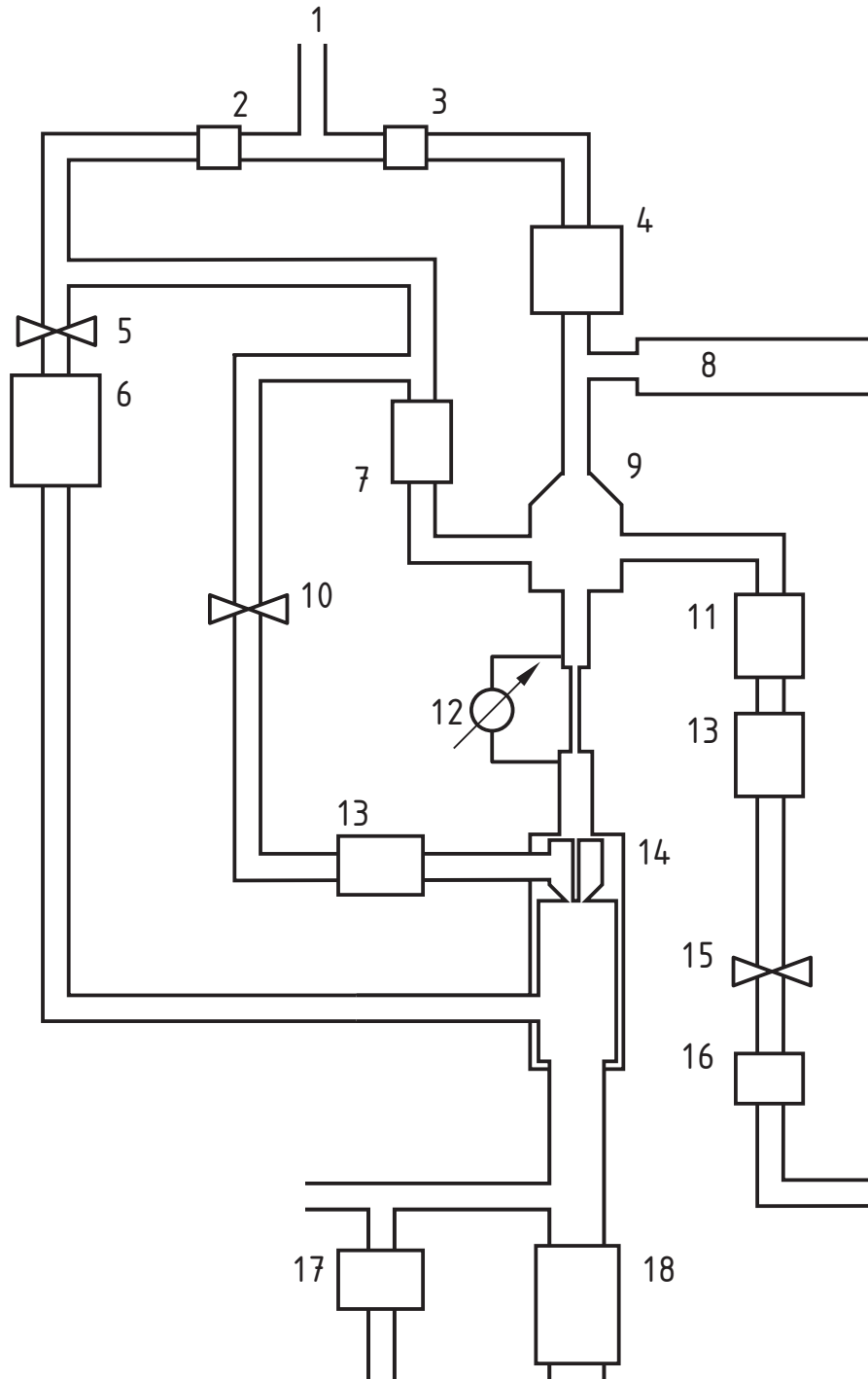
**Key**

- | | |
|--------------------------------|----------------------------------|
| 1 compressed air (800 kPa) | 10 secondary fresh air valve |
| 2 pressure reduction (200 kPa) | 11 particle filter |
| 3 pressure reduction (600 kPa) | 12 orifice-meter |
| 4 aerosol-generator | 13 flow-meter |
| 5 principal fresh air valve | 14 dilution |
| 6 fresh air flow meter | 15 aerosol waste valve |
| 7 flow-controller | 16 pump |
| 8 waste aerosol | 17 condensation particle counter |
| 9 mixing nozzle | 18 aspirating-smoke-detector |

Figure A.3 — Detailed arrangement of the apparatus Example 1 for measuring RTV

Although the set up appears rather complex, it has been designed to be able to produce a wide range of overall flow rates, ranges of aerosol concentrations and rates of increase of aerosol concentration. The principal fresh air valve **5** (see Figure A.3) is used to set the clean air flow rate, which effectively sets the overall flow rate since this is large when compared to the aerosol flow rate. Adjustment of the secondary fresh air valve **10** and the aerosol waste valve **15** allows the overall range of aerosol concentration to be set. These valves can all be set to appropriate positions for a particular type of aspirating detector, and should not normally be adjusted during a series of measurements. The flow controller **7** is an electronically controlled mass flow controller, which is used to control the dilution. By adjusting this flow controller the aerosol concentration presented to the DUT can be controlled from effectively zero to a maximum value, dependent on the settings of valves **5**, **10** and **15**.

RTV Measurement Apparatus Example 2

The apparatus described below uses a standard smoke tunnel (described in EN 54-7:2000, Annex A) as the aerosol generator and first stage of dilution. Aerosol concentration in the tunnel is measured using the instruments described in EN 54-7:2000, Annex C. A second stage of dilution is arranged using an appropriate sampling device which mixes clean air drawn from the laboratory environment with test aerosol drawn from the smoke tunnel.

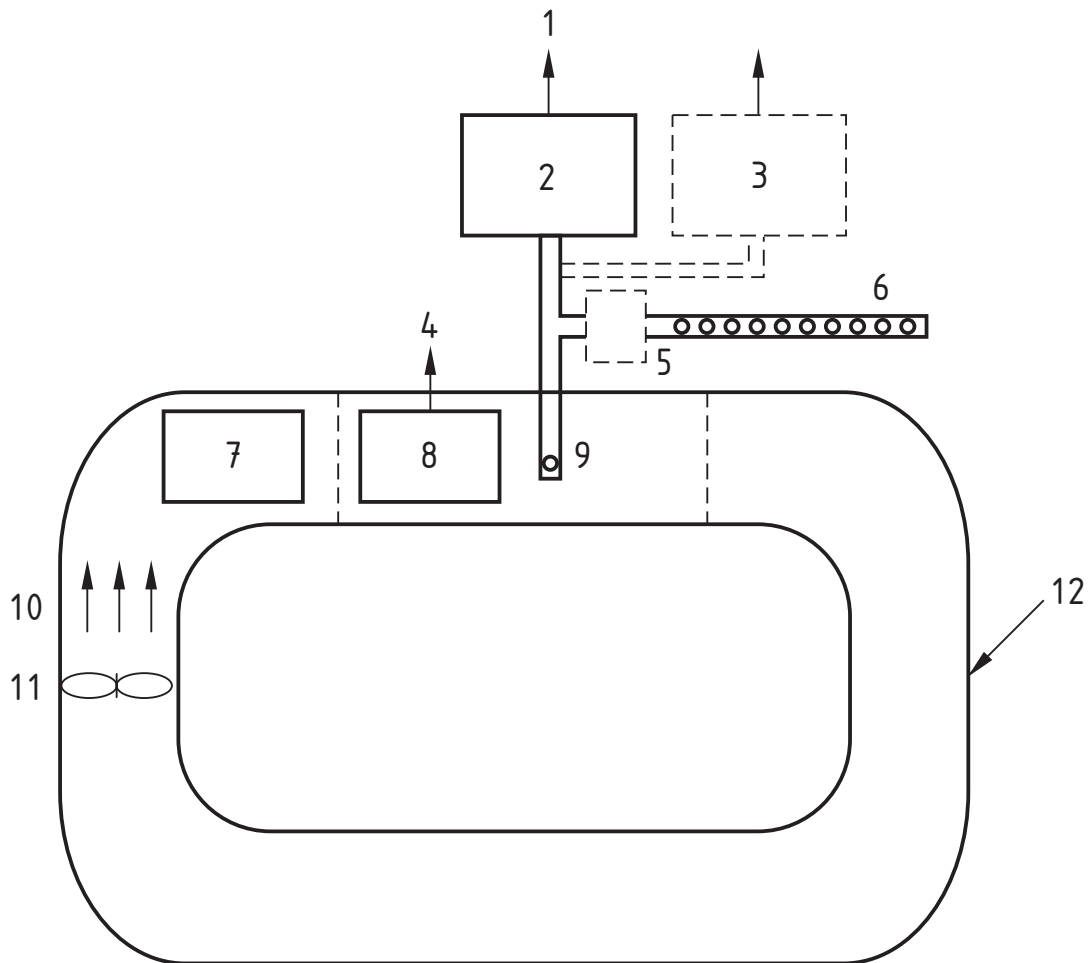
**Key**

- 1 supply and monitoring equipment
- 2 DUT – Detector under test
- 3 reference detector (optional)
- 4 N aerosol concentration
- 5 fine filter (optional)
- 6 dilution:
 - 1 sampling point in the smoke tunnel
 - n sampling points outside
- 7 aerosol generator
- 8 aerosol measurement
- 9 working volume
- 10 air flow
- 11 fan
- 12 smoke tunnel (see EN 54-7)

Figure A.4 — Arrangement of the apparatus Example 2 for measuring RTV

It is important to note that the aerosol concentration measured in the smoke tunnel is NOT a direct measurement of the aerosol concentration entering the DUT. As such it is essential that other parameters that may affect the measurement remain constant. The following are some considerations for achieving repeatable reliable results using the apparatus shown in Figure A.4.

The dilution achieved with the sampling device should be consistent and repeatable:

- it is essential that the tunnel does not leak and potentially contaminate the clean air entering the sampling device,
- it is recommended that the same physical sampling device is used in all measurements so that minor variations in the sampling device do not affect the measurements recorded,
- it is recommended that the sampling device is arranged to be as short as is practically possible to minimize the transport time.

The rate of rise of the aerosol concentration in the tunnel should be consistent and sufficiently slow to ensure that the delays inherent to the detector (including the transport delay of the sampling device and other processing delays) do not affect the results. Figure A.5 illustrates the fact that the delays (T) with variability (dT) means that a fast rate of rise in the tunnel would result in a higher (and less accurate) RTV measurement (RTV_{fast}) than a slow rate of rise (RTV_{slow}).

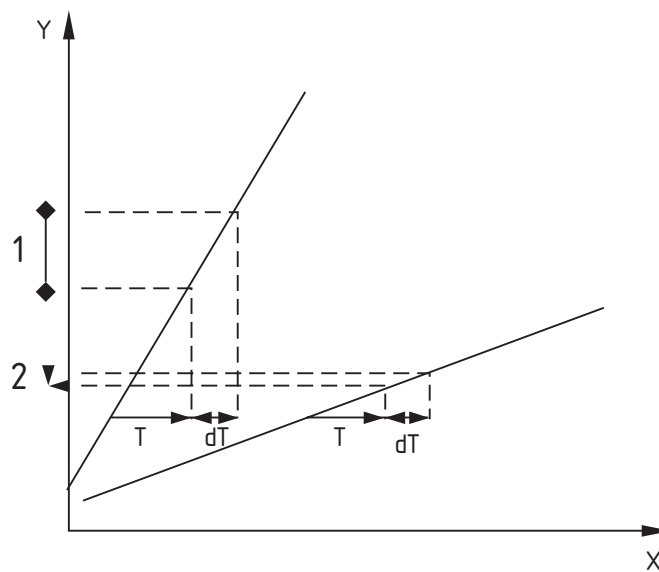

Key
 X time
 Y smoke concentration
 1 RTV_{fast}
 2 RTV_{slow}

Figure A.5 — Graph showing effect of rate on rise on RTV accuracy

Due to the possible inaccuracies in the test apparatus shown as Example 2, as a precaution, it is recommended that, where possible, a “reference sample” of the DUT is arranged in series or parallel with the DUT (as appropriate to the particular design of ASD). Such a reference sample provides confirmation that any changes in the measured RTV are a function of the experiment (hot, cold, damp heat etc.) as opposed to the test apparatus and conditions. Where the DUT does not have an output which is essentially proportional to aerosol concentration, it is recommended that another suitable instrument is used such as an alternative ASD device.

Annex B (normative)

Smouldering (pyrolysis) wood fire (TF2)

B.1 Fuel

Approximately 10 dried beech wood sticks (moisture content $\approx 5\%$), each stick having dimensions of 75 mm \times 25 mm \times 20 mm.

B.2 Hotplate

The hotplate shall have a 220 mm diameter grooved surface with eight concentric grooves, each 2 mm deep and 5 mm wide, with the outer groove 4 mm from the edge and a distance of 3 mm between grooves. The hotplate shall have a rating of approximately 2 kW.

The temperature of the hotplate shall be measured by a sensor attached to the fifth groove, counted from the edge of the hotplate, and secured to provide a good thermal contact.

B.3 Arrangement

The sticks shall be arranged on the grooved hotplate surface, with the 20 mm side in contact with the surface such that the temperature probe lies between the sticks and is not covered, as shown in Figure B.1.

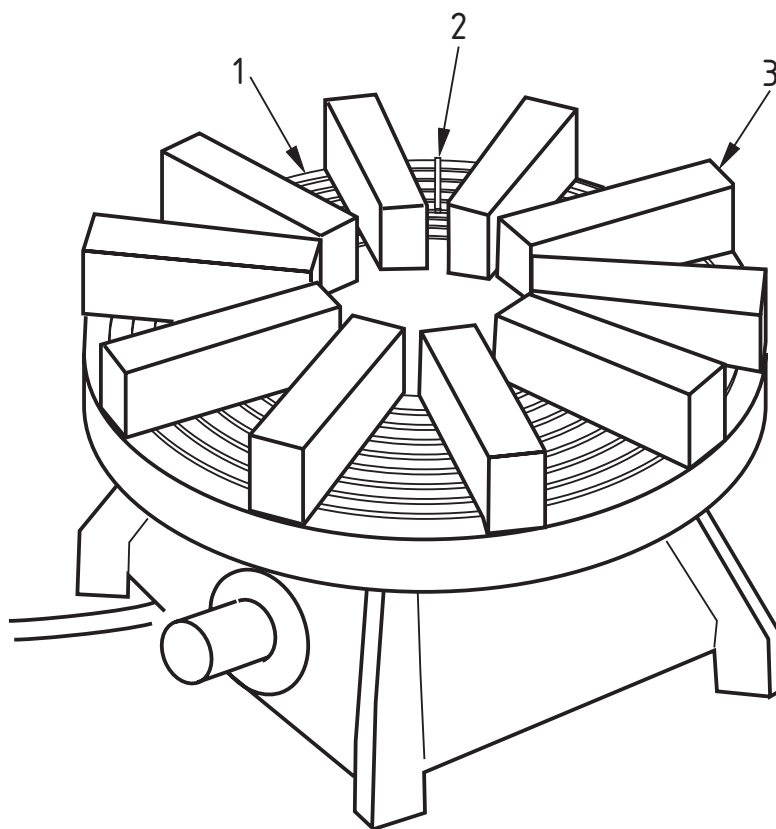
**Key**

- 1 grooved hotplate
- 2 temperature sensor
- 3 wooden sticks

Figure B.1 — Arrangement of the sticks on the hotplate

B.4 Heating rate

The hotplate shall be powered such that its temperature rises from ambient to 600 °C in approximately 11 min.

B.5 End of test condition

$$m_E = 2 \text{ dB m}^{-1}.$$

B.6 Test validity criteria

The development of the fire shall be such that the curves of m against y , and m against time fall within the limits shown in Figures B.2 and B.3 respectively and no flaming occurs, up to the time when $m = 2 \text{ dB m}^{-1}$, or the specimen has generated an alarm signal, whichever is the earliest.

If the end of test condition, $m_E = 2 \text{ dB m}^{-1}$, is reached before the specimen of detector using ionization has responded, then the test is only considered valid if a y -value of 1,6 has been reached.

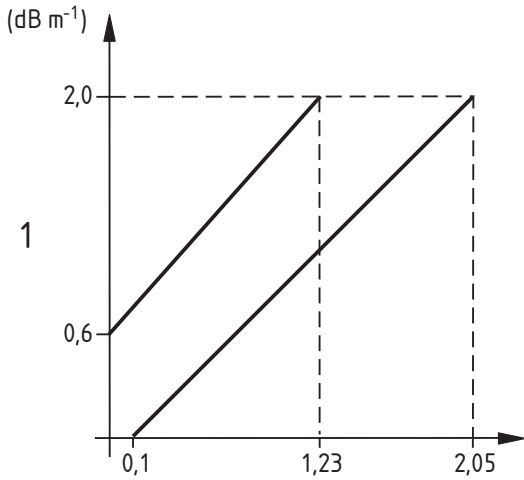

Key
 1 *m*-value
 2 *y*-value

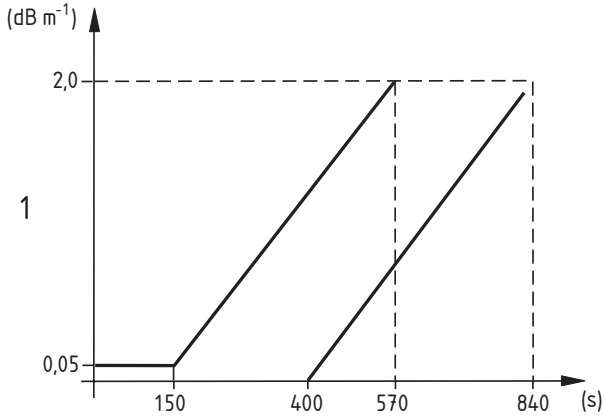

Key
 1 *m*-value
 2 time

Figure B.1 — Limits for *m* against *y*, Fire TF2

Figure B.2 — Limits for *m* against time, Fire TF2

Licensed copy: Southbank University, 26/03/2008, Uncontrolled Copy, © BSI

Annex C (normative)

Reduced smouldering pyrolysis wood fires (TF2A and TF2B)

C.1 Fuel

Three or more dried beech wood sticks (moisture content ~ 5 %), each stick having dimensions of approximately 75 mm × 25 mm × 20 mm.

C.2 Hotplate

The hotplate shall have a 220 mm diameter grooved surface with eight concentric grooves, each 2 mm deep and 5 mm wide, with the outer groove 4 mm from the edge and a distance of 3 mm between grooves. The hotplate shall have a rating of approximately 2 kW.

The temperature of the hotplate shall be measured by a sensor attached to the fifth groove, counted from the edge of the hotplate, and secured to provide a good thermal contact.

C.3 Arrangement

The sticks shall be arranged on the grooved hotplate surface, with the 20 mm side in contact with the surface such that the temperature probe lies between the sticks and is not covered, as shown in Figure C.1.

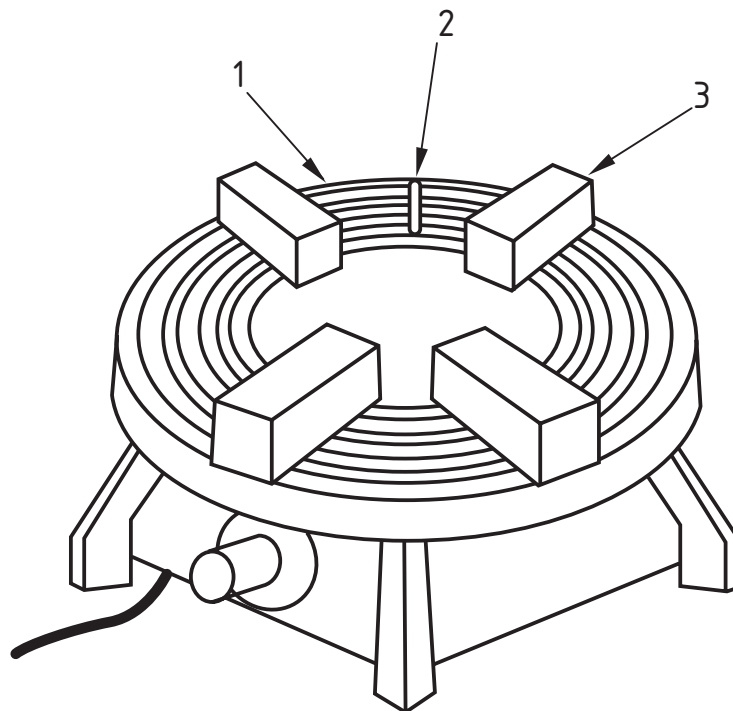
**Key**

- 1 grooved hotplate
- 2 temperature sensor
- 3 3 (or more) wooden sticks

Figure C.1 — Arrangement of the sticks on the hotplate

C.4 Heating rate

The hotplate shall be powered such that its temperature rises from ambient to the target temperature in approximately 11 min.

The target temperature for the reduced test fires shall be 500 °C.

NOTE For the TF2 test (used for Class C detectors), the target temperature is 600 °C.

C.5 End of test condition

| | | |
|----------|---------|--------------------------------|
| For TF2A | Class A | $m_E = 0,05 \text{ dB m}^{-1}$ |
| For TF2B | Class B | $m_E = 0,15 \text{ dB m}^{-1}$ |

C.6 Test validity criteria

The development of the fire shall be such that the curves of m against time for TF2A and TF2B fall within the limits shown in Figures C.2 and C.3 respectively, and no flaming occurs, up to the time when $m = \text{EOT condition}$, or the specimen has generated an alarm signal, whichever is the earliest.

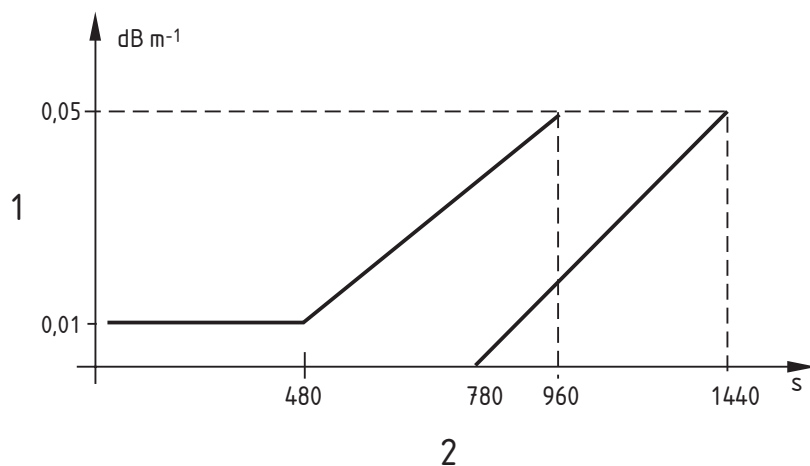

Key
 1 m -value
 2 time

Figure C.2 — Limits for m against time, Fire TF2A

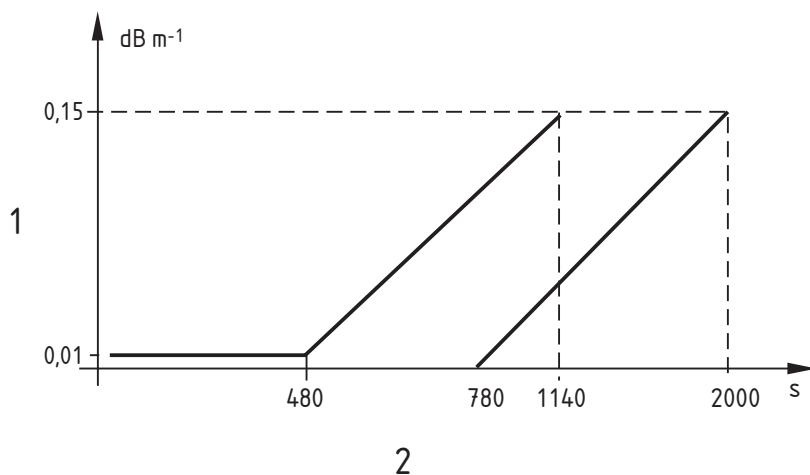

Key
 1 m -value
 2 time

Figure C.3 — Limits for m against time, Fire TF2B

Annex D

(normative)

Glowing smouldering cotton fire (TF3)

D.1 Fuel

Approximately 90 pieces of braided cotton wick, each approximately 80 cm long and weighing approximately 3 g. The wicks shall be free from any protective coating and shall be washed and dried if necessary.

D.2 Arrangement

The wicks shall be fastened to a ring approximately 10 cm in diameter and suspended approximately 1 m above a non-combustible plate as shown in Figure D.1.

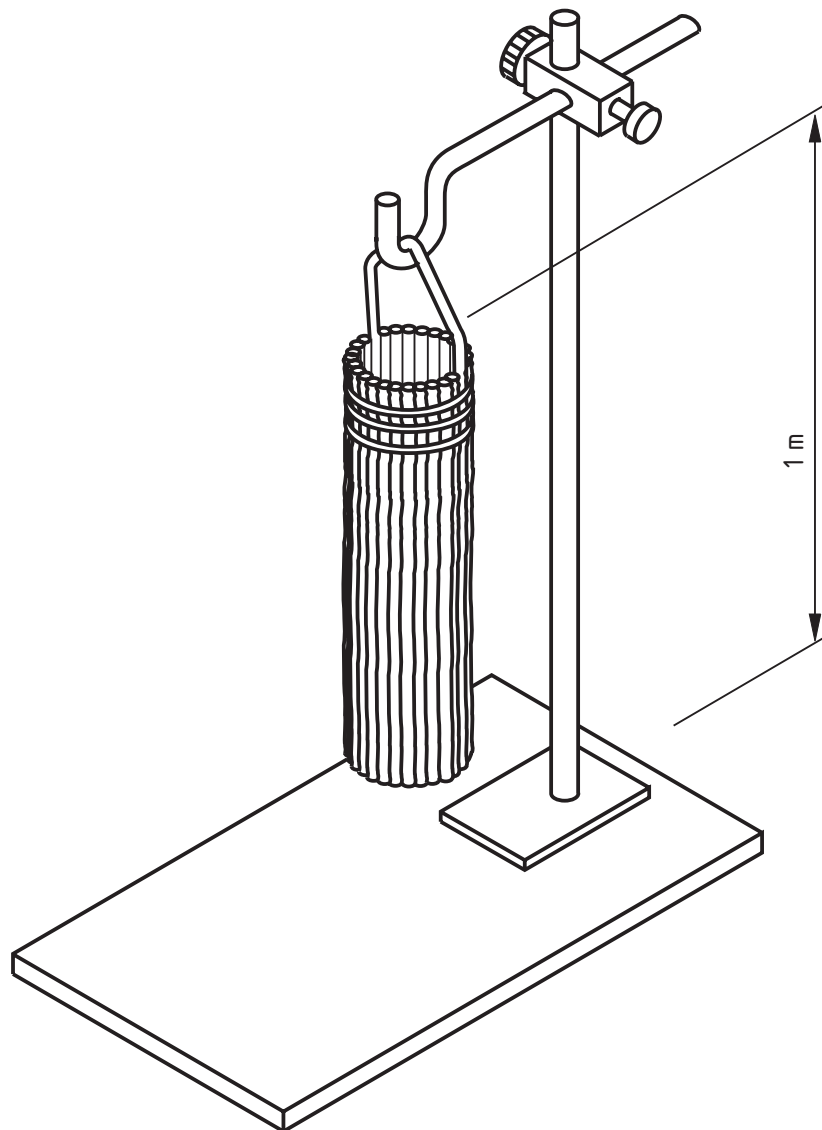

Figure D.1 — Arrangement of the cotton wicks

D.3 Ignition

The lower end of each wick shall be ignited so that the wicks continue to glow. Any flaming shall be blown out immediately. The test time shall start when all wicks are glowing.

D.4 End of test condition

$$m_E = 2 \text{ dB m}^{-1}$$

D.5 Test validity criteria

The development of the fire shall be such that the curves of m against y , and m against time, fall within the limits shown in Figures D.2 and D.3 respectively, up to the time when $m = 2 \text{ dB m}^{-1}$, or the specimen has generated an alarm signal, whichever is the earliest.

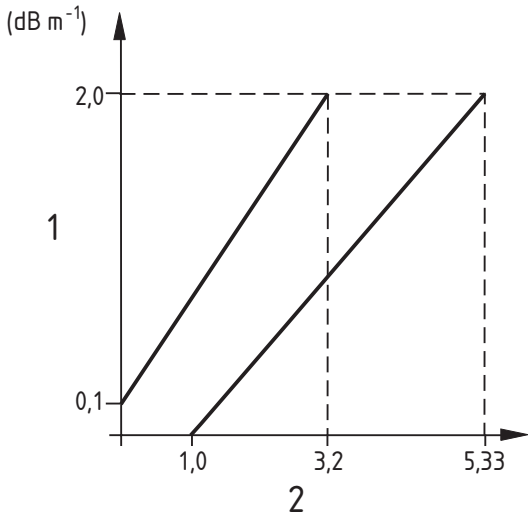

Key
 1 *m*-value
 2 *y*-value

Figure D.2 — Limits for *m* against *y*, Fire TF3

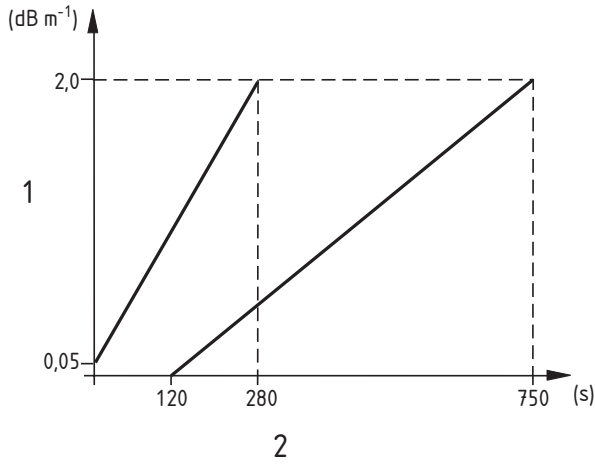

Key
 1 *m*-value
 2 time

Figure D.3 — Limits for *m* against time, Fire TF3

Annex E (normative)

Reduced glowing smouldering cotton fire (TF3A and TF3B)

E.1 Fuel

Approximately 30 or 40 pieces of braided cotton wick, each approximately 80 cm long and weighing approximately 3 g. The wicks shall be free from any protective coating and shall be washed and dried if necessary.

E.2 Arrangement

The wicks shall be fastened to a ring approximately 10 cm in diameter and suspended approximately 1 m above a non-combustible plate. The wicks shall be positioned adjacent to one another and the remaining open part of the arc shall be completed using a curved sheet of non-combustible material to complete the "chimney" as shown in Figure E.1.

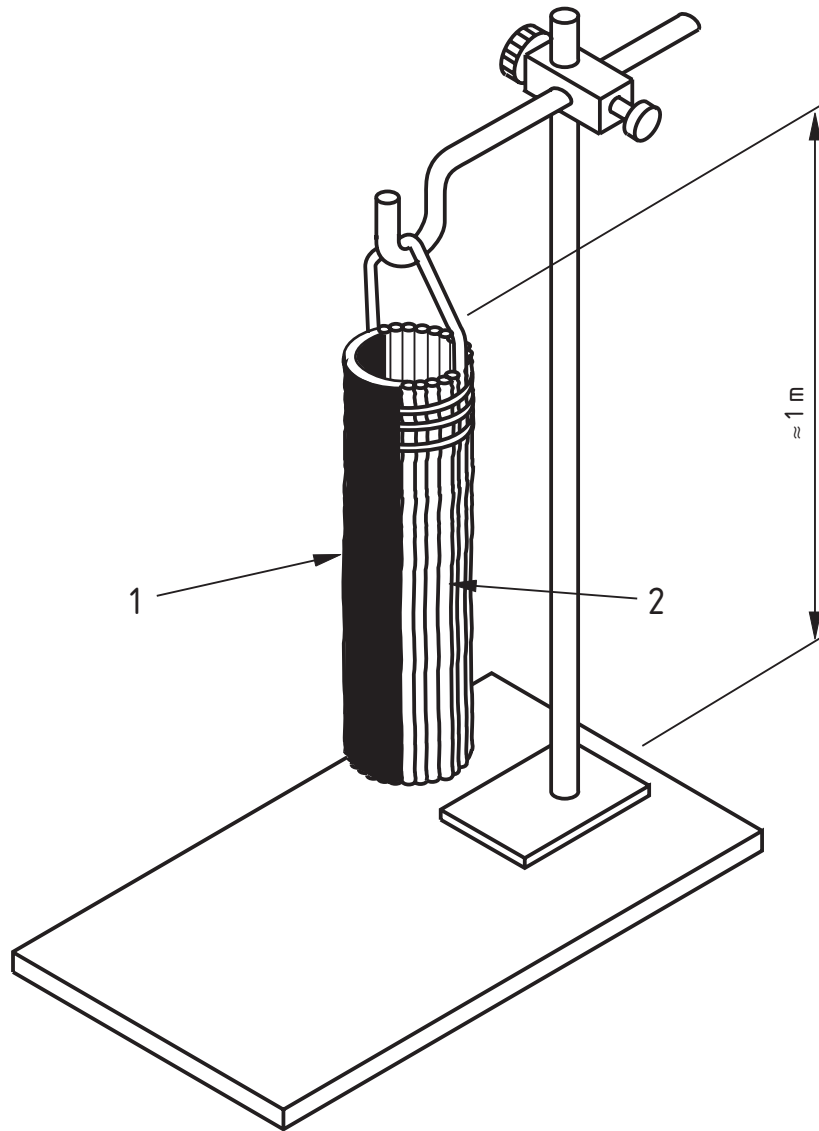
**Key**

- 1 curved sheet of non combustible material
 2 cotton wicks

Figure E.1 — Arrangement of the cotton wicks

E.3 Ignition

The lower end of each wick shall be ignited so that the wicks continue to glow. Any flaming shall be blown out immediately. The test time shall start when all wicks are glowing.

E.4 End of test condition

| | | |
|----------|---------|--------------------------------|
| For TF3A | Class A | $m_E = 0,05 \text{ dB m}^{-1}$ |
| For TF3B | Class B | $m_E = 0,15 \text{ dB m}^{-1}$ |

E.5 Test validity criteria

The development of the fire shall be such that the curve of m against time, for TF3A and TF3B, fall within the limits shown in Figures E.2 and E.3 respectively, up to the time when $m = \text{EOT condition}$, or the specimen has generated an alarm signal, whichever is the earliest.

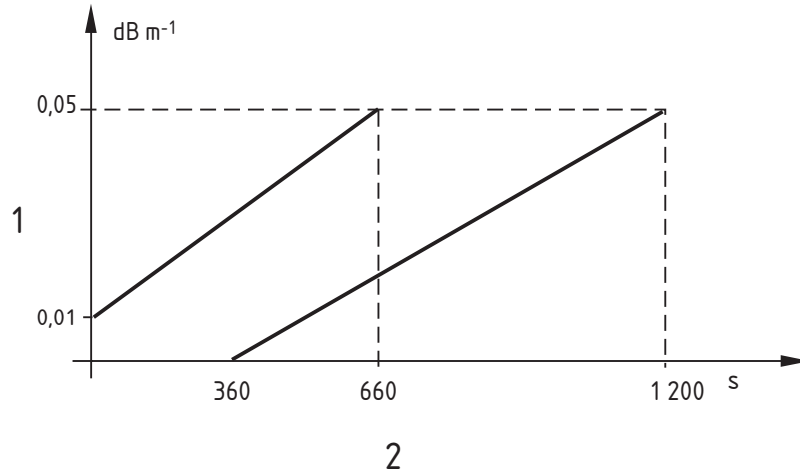

Key
 1 m -value
 2 time

Figure E.2 — Limits for m against time, Fire TF3A

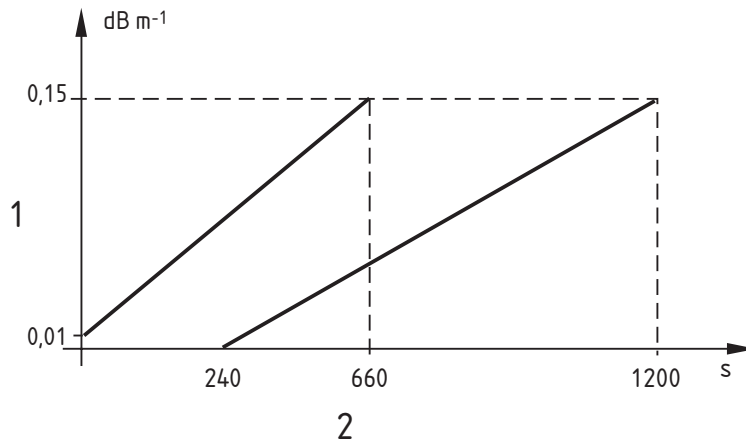

Key
 1 m -value
 2 time

Figure E.3 — Limits for m against time, Fire TF3B

Annex F (normative)

Flaming plastics (polyurethane) fire (TF4)

F.1 Fuel

Soft polyurethane foam, without flame retardant additives and having a density of approximately 20 kg m^{-3} . Three mats, approximately $50 \text{ cm} \times 50 \text{ cm} \times 2 \text{ cm}$ are usually found sufficient, however the exact fuel quantity may be adjusted to obtain valid tests.

F.2 Arrangement

The mats shall be placed one on top of another on a base formed from aluminium foil with the edges folded up to provide a tray.

F.3 Ignition

The mats shall normally be ignited at a corner of the lower mat, however the exact position of ignition may be adjusted to obtain valid tests. A small quantity of a clean burning material (e.g. 5 cm^3 of methylated spirit) may be used to assist the ignition.

F.4 End of test condition

$$y_E = 6$$

F.5 Test validity criteria

The development of the fire shall be such that the curves of m against y , and m against time fall within the limits shown in Figures F.1 and F.2 respectively, up to the time when $y = 6$, or the specimen has generated an alarm signal, whichever is the earliest.

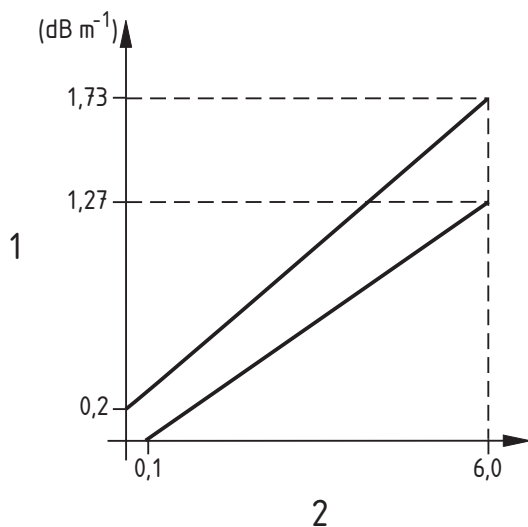

Key
 1 m -value
 2 y -value

**Figure F.1 — Limits for m against y ,
 Fire TF4**

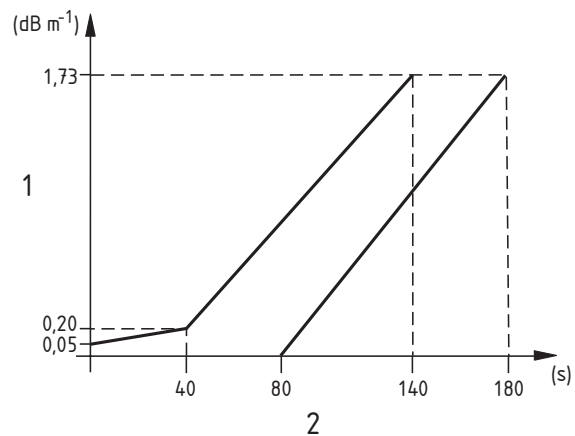

Key
 1 m -value
 2 time

**Figure F.2 — Limits for m against time,
 Fire TF4**

Annex G (normative)

Flaming liquid (n-heptane) fire (TF5)

G.1 Fuel

Approximately 650 g of a mixture of n-heptane (purity $\geq 99\%$) with approximately 3 % of toluene (purity $\geq 99\%$), by volume. The precise quantities may be varied to obtain valid tests.

G.2 Arrangement

The heptane/toluene mixture shall be burnt in a square steel tray with dimensions approximately 33 cm \times 33 cm \times 5 cm.

G.3 Ignition

Ignition shall be by flame or spark etc.

G.4 End of test condition

$$y_E = 6$$

G.5 Test validity criteria

The development of the fire shall be such that the curves of m against y , and m against time, fall within the limits shown in Figures G.1 and G.2 respectively, up to the time when $y = 6$, or the specimen has generated an alarm signal, whichever is the earliest.

If the end of test condition, $y_E = 6$, is reached before the specimen of detector using scattered or transmitted light has responded, then the test is only considered valid if an m -value of 1,1 dB m⁻¹ has been reached.

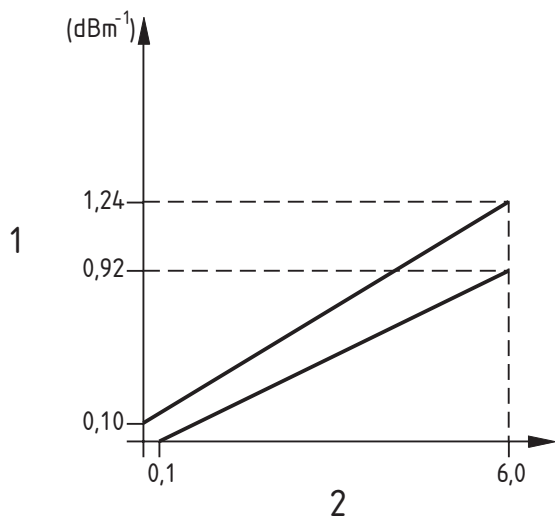

Key
 1 *m*-value
 2 *y*-value

Figure G.1 — Limits for *m* against *y*, Fire TF5

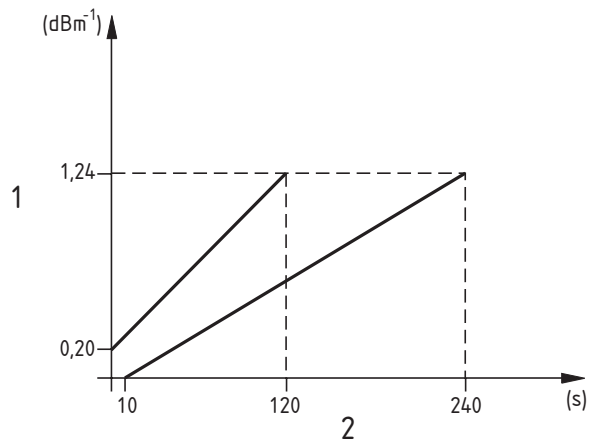

Key
 1 *m*-value
 2 time

Figure G.2 — Limits for *m* against time, Fire TF5

Annex H (normative)

Reduced flaming liquid (n-heptane) fire (TF5A and TF5B)

H.1 Fuel

Approximately 200 ml (TF5A) or 300 ml (TF5B) of n-heptane (purity ~ 99 %), by volume. The precise quantities may be varied to obtain valid tests.

NOTE The use of toluene in the n-heptane is not accepted, since the presence of toluene in the fuel will significantly modify the behaviour of the fire giving an initial peak burn which is not suitable for reduced test fires.

H.2 Arrangement

The heptane shall be burnt in a square, 2 mm thick, steel tray with dimensions approximately:

| | | |
|-----|------|--------------------------|
| For | TF5A | 100 mm × 100 mm × 100 mm |
| | TF5B | 175 mm × 175 mm × 100 mm |

placed on a 2 mm thick sheet metal base with dimensions of approximately 350 mm × 350 mm as illustrated in Figure H.1.

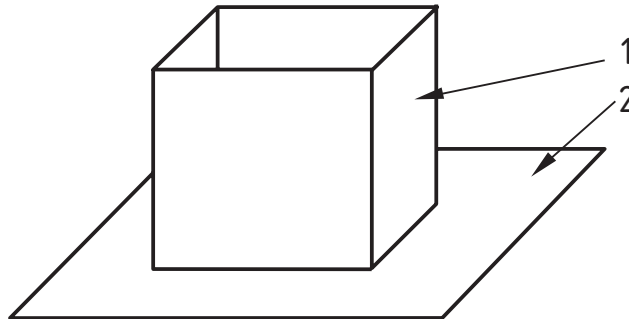

Key

- 1 tray
- 2 base plate

Figure H.1 — Arrangement of the tray for test fire TF5A and TF5B

NOTE The base plate may be the tray used in TF5 and is needed to act as a heat sink to avoid boiling of the small quantities of fuel used in the reduced test fires.

H.3 Ignition

Ignition shall be by flame or spark etc.

H.4 End of test condition

For TF5A (Class A) $m = 0,1 \text{ dB m}^{-1}$
 For TF5B (Class B) $m = 0,3 \text{ dB m}^{-1}$

H.5 Test validity criteria

The development of the fire shall be such that the curves of m against time for TF5A and TF5B fall within the limits shown in Figure H.2 and H.3 respectively, up to the time when $m = \text{EOT condition}$, or the specimen has generated an alarm signal, whichever is the earliest.

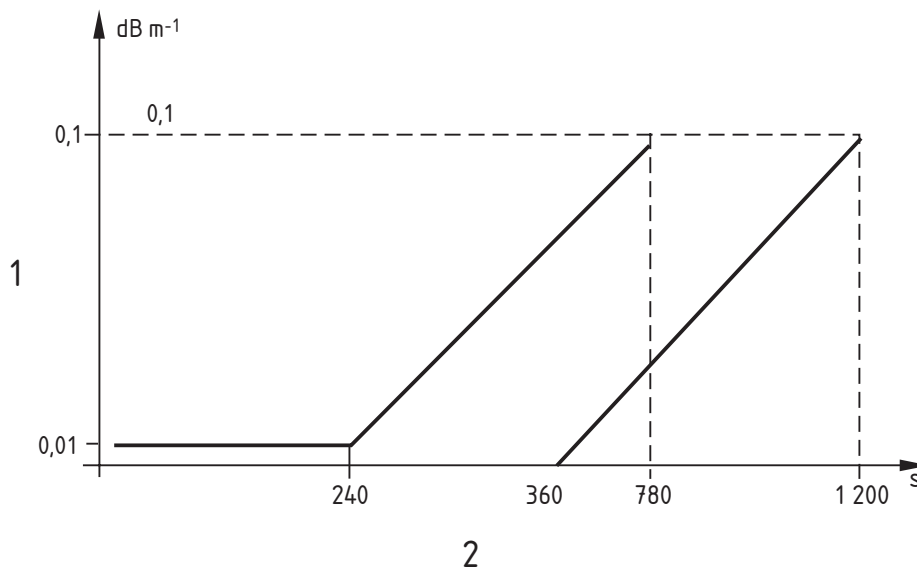

Key
 1 m -value
 2 time

Figure H.2 — Limits for m against time, Fire TF5A

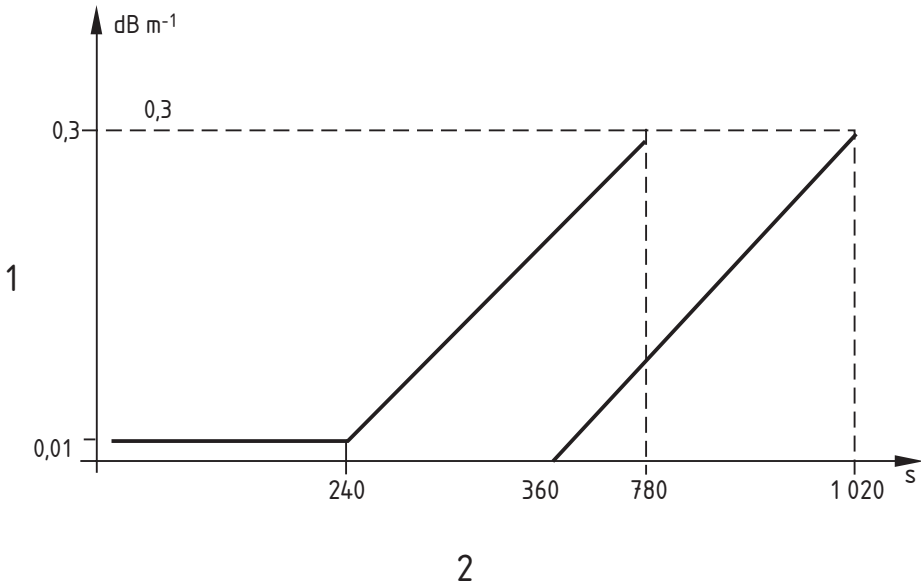

Key
1 *m*-value
2 time

Figure H.3 — Limits for *m* against *time*, Fire TF5B

Annex I (normative)

Fire test room and ventilation system

I.1 Fire test room

The sampling point, the MIC, the temperature probe and the measuring part of the obscuration meter shall all be located within the volume shown in Figures I.1 and I.2.

The sampling point shall be located on the 3 m arc marked 1 in Figure I.1. The optimum position is marked 2 in Figure I.1.

The ventilation system shall be located in the position marked 3 in Figure I.1. The air flow produced by this system shall be in the direction of the test fire (located at the position marked 4 in Figure I.1). The description of the ventilation system is given in I.2.

The sampling point, the MIC and the mechanical parts of the obscuration meter shall be at least 100 mm apart, measured to the nearest edges. The centre line of the beam of the obscuration meter shall be at least 35 mm below the ceiling.

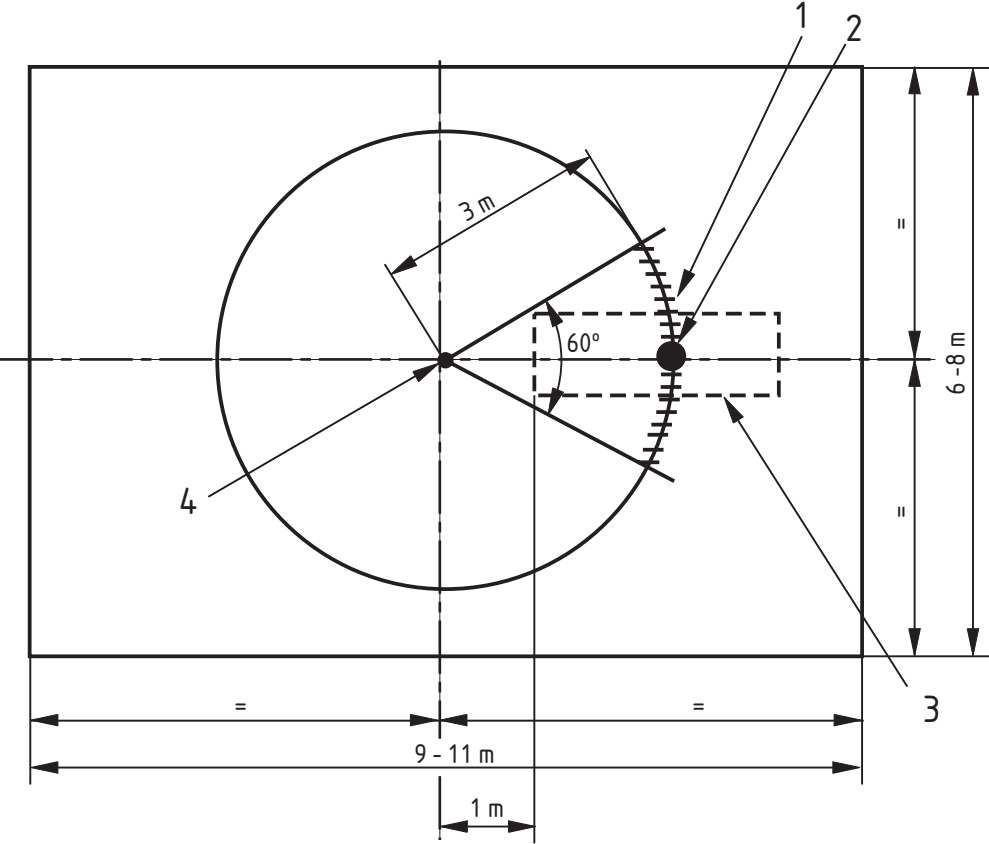

- Key**
- 1 sampling point and measuring instruments (see Figure I.2)
 - 2 optimum position of the sampling point
 - 3 ventilation system (see Figure I.3)
 - 4 position of test fire

Figure I.1 — Plan view of the fire test room

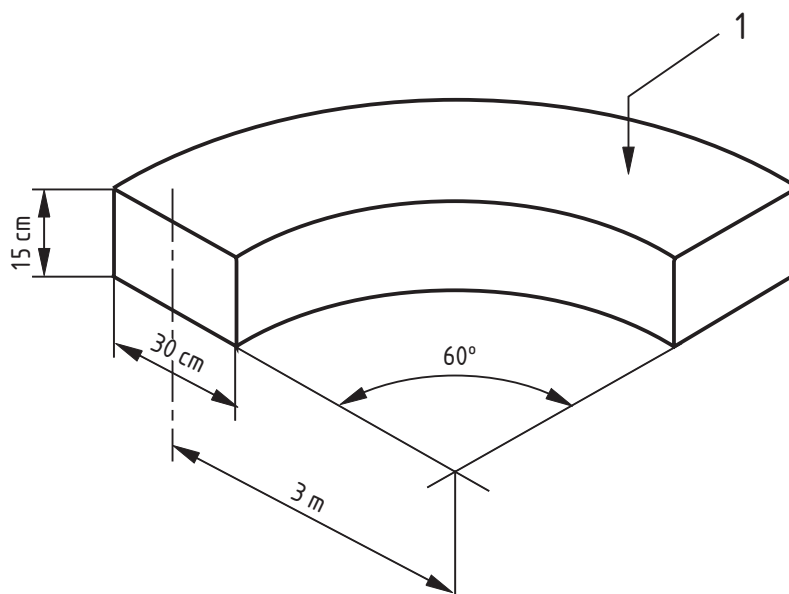
**Key**

1 ceiling

Figure I.2 — Mounting position for specimens and measuring instruments**I.2 Ventilation system**

As a consequence of the low quantity of aerosols generated by reduced fire tests, it is necessary, for the reduced fire tests TF2A, TF2B, TF3A, TF3B, TF5A and TF5B, to introduce in the fire test room a ventilation system to increase the homogeneity of the atmosphere close to the sampling points. The following specifies those characteristics of the ventilation system which are of primary importance.

The ventilation system consists of a square duct opened in both extremities (see Figure I.3).

A fan is located in the duct as described in Figure I.3. The diameter of the fan shall be as close as possible of the dimensions of the sides of the square section of the duct. At the location of the fan, the section of the duct not occupied by the van shall be closed. The axis of the fan shall be the same as the axis of the square duct.

The ventilation system shall create an air flow at $(1,0 \pm 0,2) \text{ m s}^{-1}$ at the output of the duct (the air flow direction is given in Figure I.3). Conformity with this requirement shall be regularly verified during the fire tests, by measurements at the centre of the duct output section (see Position 6 in Figure I.3).

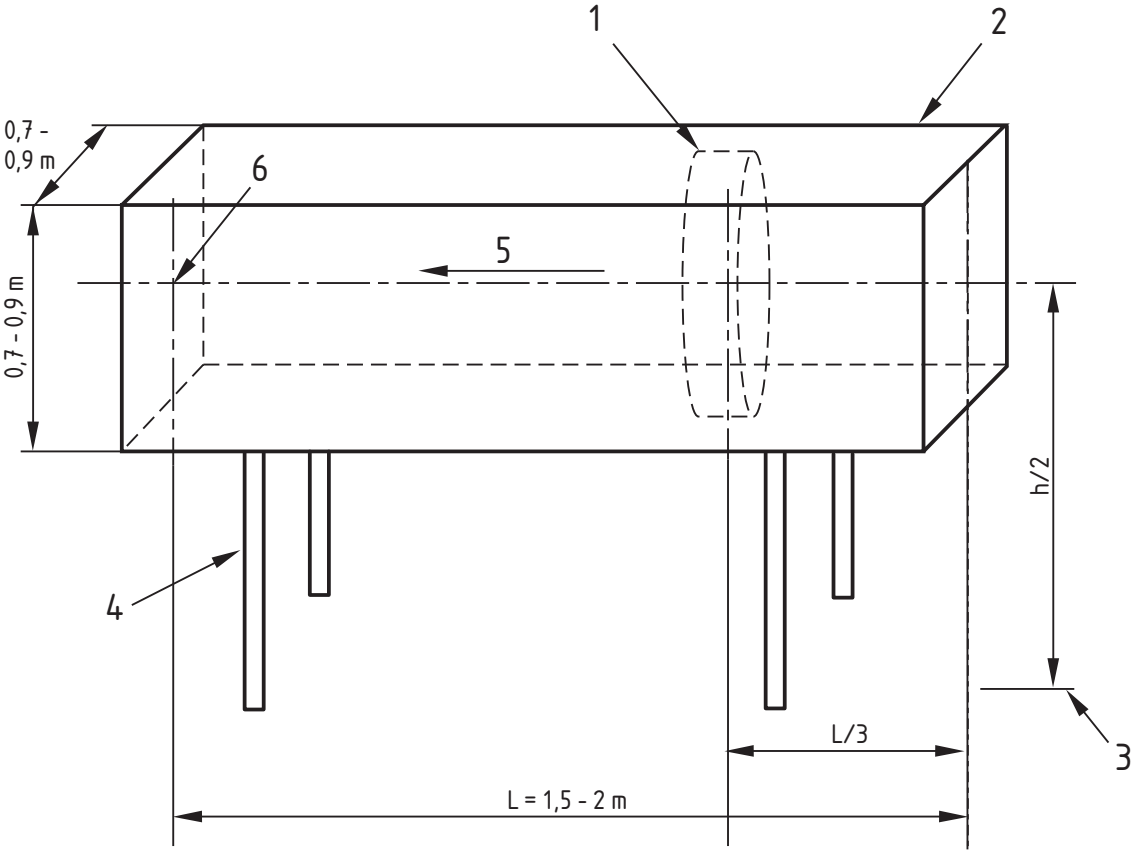

- Key**
- 1 fan
 - 2 square duct
 - 3 ground
 - 4 stand
 - 5 air flow
 - 6 location of the flow velocity measurement
 - h height of the fire test room (as described in 5.18.3.1 of EN 54-7:2000)
 - L length of the duct

Figure I.3 — Ventilation system

Annex J (informative)

Information concerning the requirements for the response to slowly developing fires

A simple detector operates by comparing the signal from the sensor with a certain fixed threshold (alarm threshold). When the sensor signal reaches the threshold, the detector generates an alarm signal. The smoke density at which this occurs is the response threshold value for the detector. In this simple detector the alarm threshold is fixed and does not depend on the rate of change of sensor signal with time.

It is known that the sensor signal in clean air can change over the life of the detector. Such changes can be caused, for example, by contamination of the sensing chamber with dust or by other long-term effects such as component ageing. This drift can, in time, lead to increased sensitivity and eventually to false alarms.

It may be considered beneficial therefore to provide compensation for such drift to maintain a more constant level of response threshold value with time. It is assumed that the compensation is achieved by increasing the alarm threshold to offset some or all of the upward drift in the sensor output.

Any compensation for drift will reduce the sensitivity of the detector to slow changes in the sensor output even if these changes are caused by a real, but gradual, increase in smoke level. The object of requirement 5.6a) is to ensure that the compensation does not reduce the sensitivity to a slowly developing fire to an unacceptable degree.

For the purposes of this standard it is assumed that the development of any fire which presents a serious danger to life or property will be such that the sensor output will change at a rate of at least $A/4$ per hour where A is the nominal response threshold value of the detector. The response to rates of change less than $A/4$ per hour is not specified in this standard, and there is therefore no requirement for the detector to respond to these lower rates of change.

To avoid restricting the way in which compensation is achieved, 5.6 requires only that the time to alarm, for all rates of change greater than $A/4$ per hour, does not exceed $1,6 \times$ the time to alarm, if the compensation were not present.

If the threshold increases in a linear fashion with time in response to a rise in the sensor signal, and if the extent of the compensation is not limited, then the maximum rate of compensation allowed can be seen from Figure J.1 to be $0,6A/6,4 = 0,094A$ per hour, since at this compensation rate the sensor output will reach the compensated threshold in exactly 6,4 h.

Although it has been assumed above that the threshold is compensated linearly and continuously, the process need not be linear or continuous. For example, the stepwise adjustment shown in Figure J.2 also meets the requirement since, in this case, an alarm is reached in 6 h, which is less than the limiting value of 6,4 h.

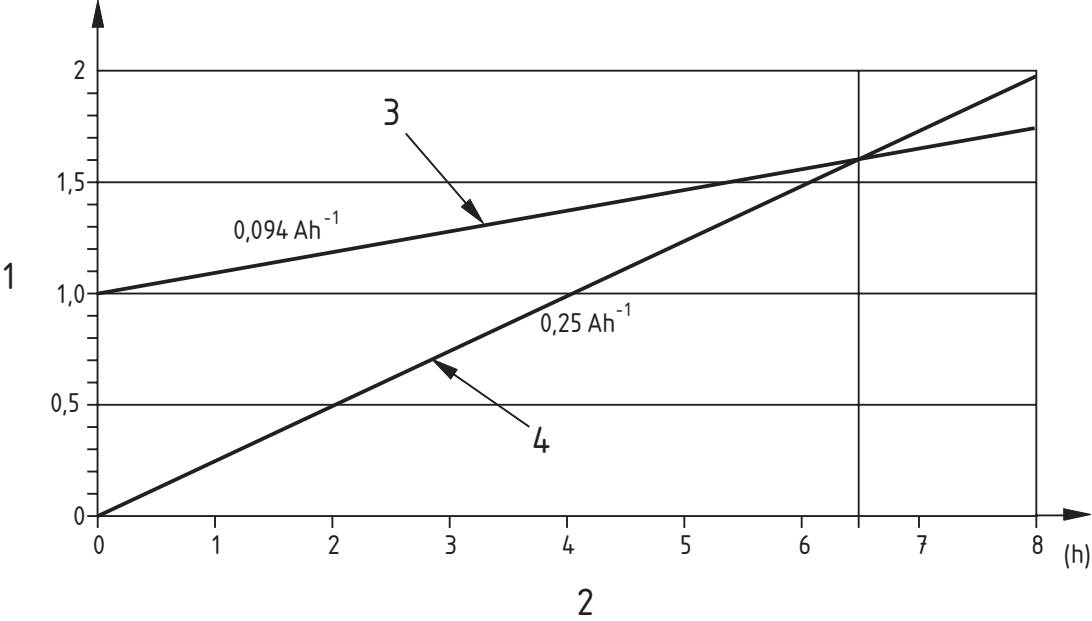

Key
1 relative alarm threshold (relative to A) 3 compensated alarm threshold
2 time 4 sensor output

Figure J.1 — Linear compensation – limiting case

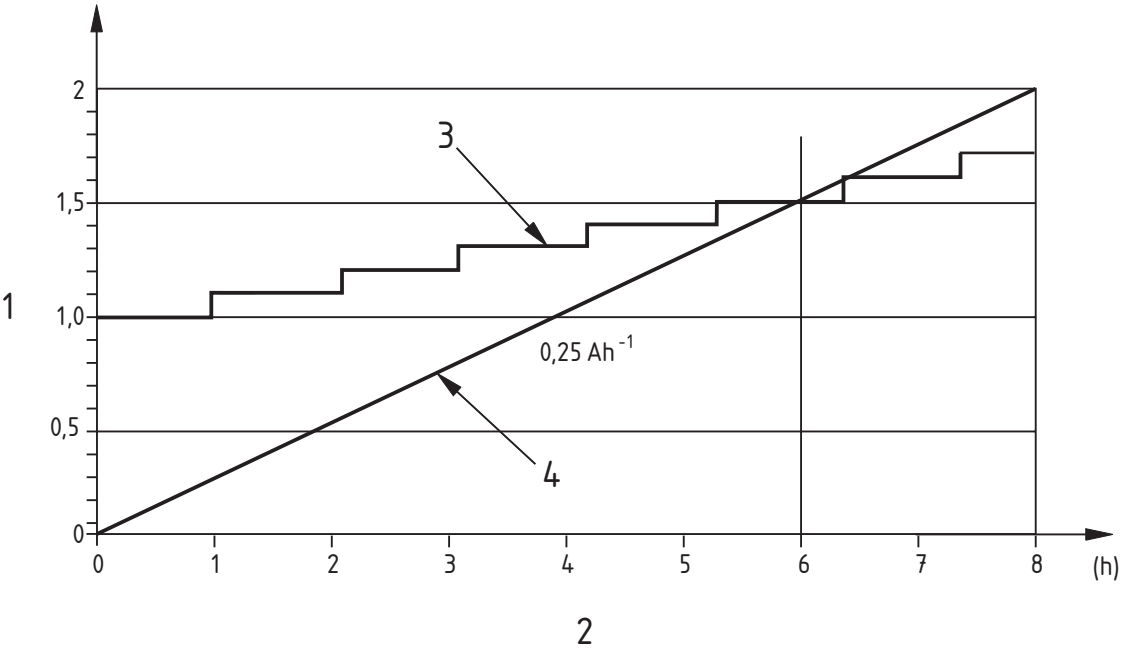

Key
1 relative alarm threshold (relative to A) 3 compensated alarm threshold
2 time 4 sensor output

Figure J.2 — Stepwise compensation – limiting case

Furthermore, the rate of compensation need not be limited to 0,094A per hour if the extent of the compensation is restricted to 0,6A. The relatively rapid rate of compensation shown in Figure J.3 also meets the requirement in reaching an alarm condition in 6,4 h. In this case the maximum rate of compensation will be limited only by the requirements of the test fires.

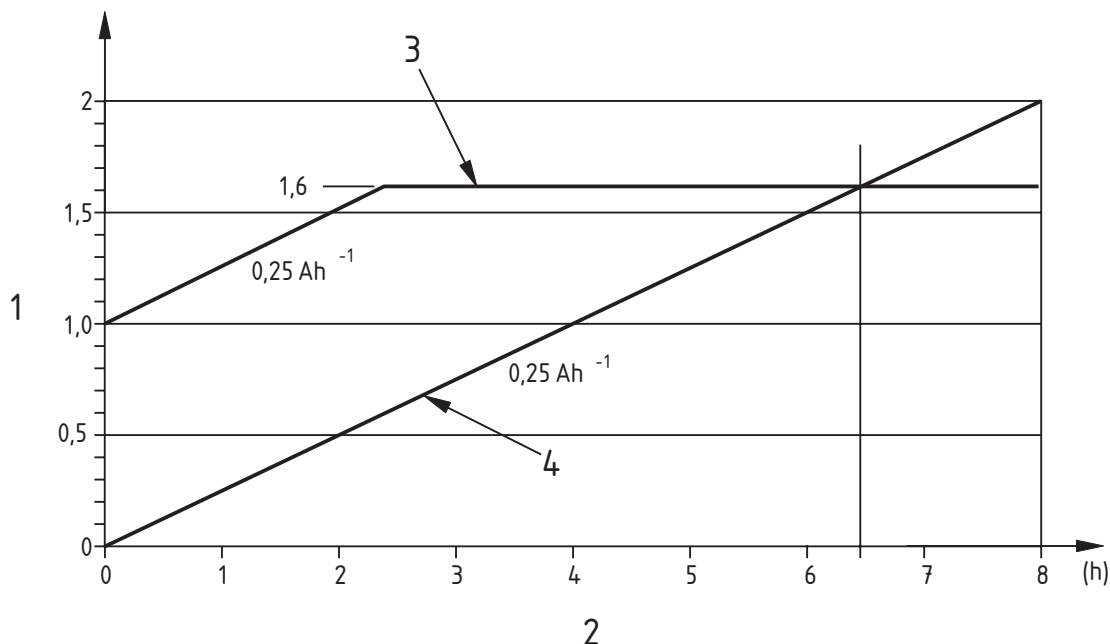

Key

- | | |
|--|-------------------------------|
| 1 relative alarm threshold (relative to A) | 3 compensated alarm threshold |
| 2 time | 4 sensor output |

Figure J.3 — High-rate, limited-extent compensation

The requirements of 5.6a) allow considerable freedom in the way in which compensation for slow changes is achieved. However, it is recognized that in any practical detector the range over which the output of the sensor is linearly related to smoke (or other stimulus which is equivalent to smoke) is finite. If the range of compensation takes the sensor output into this non-linear region then the sensitivity of the detector could become degraded to an unacceptable degree.

As an example, consider a detector having the transfer characteristic shown in Figure J.4, in which both axes are expressed in terms of response threshold value A. The non-linearity of the characteristic causes the effective sensitivity to reduce at higher values of stimulus. In this instance, it is necessary to limit the compensation to less than $1,1 \times A$, since, to produce a change in output of A, the stimulus has to increase from $1,1 \times A$ to $2,7 \times A$. This reduction in sensitivity by a factor of 1,6 represents the maximum allowed by 5.6b).

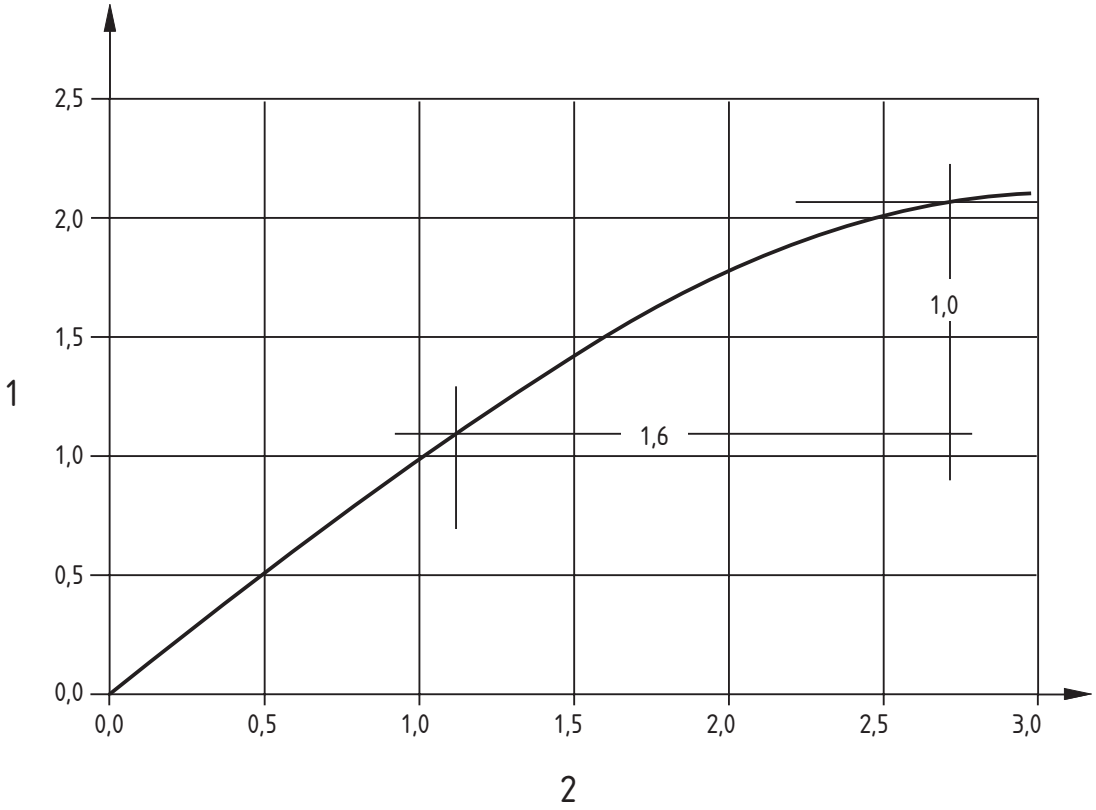

Key
1 output
2 stimulus

Figure J.4 — Example of non-linear transfer characteristic

Annex K (informative)

Apparatus for air flow monitoring test

K.1 General

This annex describes the apparatus and procedure for the airflow monitoring test.

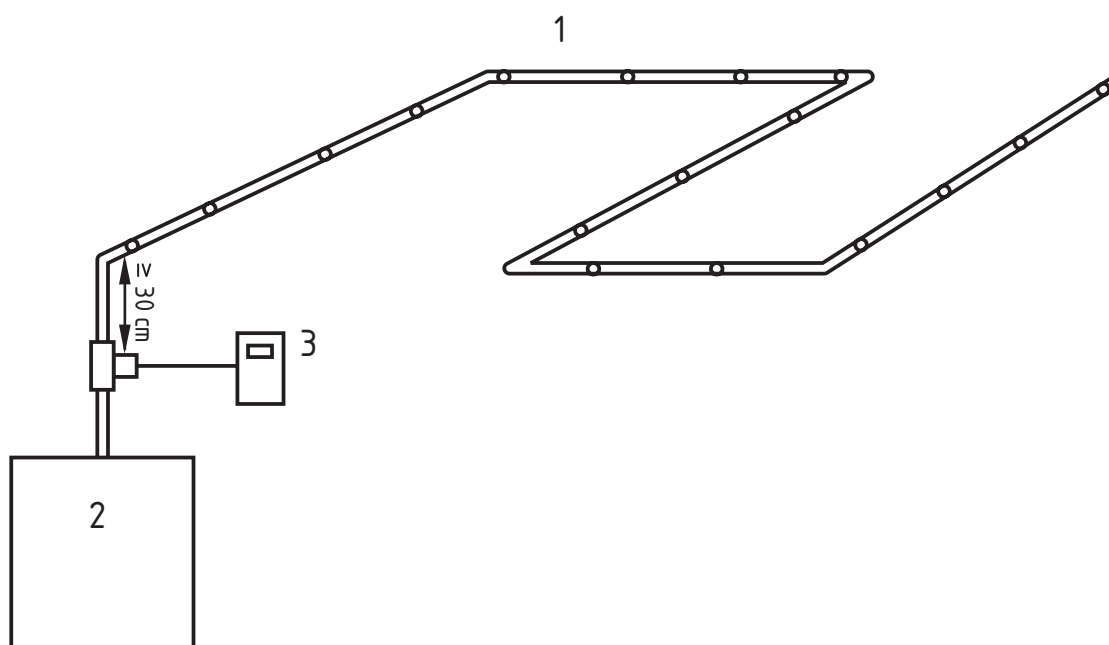

Key

- 1 worst-case sampling device (defined by manufacturer)
- 2 DUT – Detector under test
- 3 anemometer

Figure K.1 — Air flow measuring with worst-case pipe network

K.2 Airflow measuring with worst-case sampling device

Using the equipment shown in Figure K.1:

- a) DUT is set up in accordance with the manufacturer's instructions,
- b) the normal air flow value (F_n) is measured using a suitably calibrated flow meter such as an anemometer with the worst-case sampling device (as defined by manufacturer for the fire tests),
- c) there is no sampling point between the DUT and the anemometer,
- d) the minimum distance between the anemometer and the first sampling point is 30 cm.

NOTE In this example the air flow value is the air speed (m/s) which is directly correlated to the volumetric airflow as required in 6.1.6.

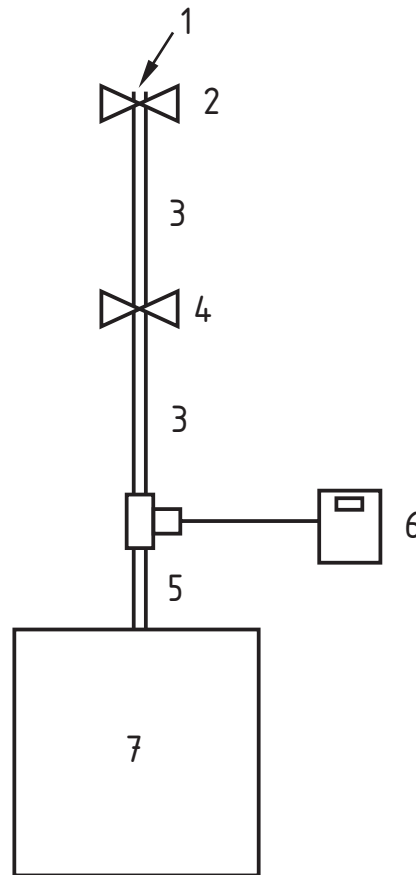

Key

- 1 open pipe
- 2 secondary flow control valve
- 3 test pipe network (1-2 m without sampling points)
- 4 primary flow control valve
- 5 minimum distance 30 cm
- 6 anemometer
- 7 DUT

Figure K.2 — Air flow measuring with test pipe network

K.3 Airflow monitoring test with test pipe network

Using the equipment shown in Figure K.2:

- a) DUT is set up with test pipe network,
- b) set the secondary flow control valve **2** to middle position. This allows variation of the air flow value in both directions (+/- 20 %) when required,

- c) using the primary flow control valve **4**, adjust the flow rate until the reading is within +/- 10 % of the normal air flow value (F_n measured in K.2) to give the Test flow value (F_t).

The same test pipe network is used for the environmental tests in which the air flow monitoring is tested.

Annex ZA (informative)

Clauses of this European Standard addressing the provisions of the EU Construction Products Directive (89/106/EEC)

ZA.1 Scope and relevant clauses

This European Standard has been prepared under Mandate M/109 given to CEN by the European Commission and the European Free Trade Association.

The clauses of this European Standard, shown in this annex, meet the requirements of the Mandate given under the EU Construction Products Directive (89/106/EEC).

Compliance with these clauses confers a presumption of fitness (as defined by the Construction Products Directive) of the construction product covered by this European Standard for its intended use according to Clause 1 (Scope) of this standard; reference shall be made to the information given with the CE marking (see ZA.3)

WARNING —Other requirements and other EU Directives may be applicable to the product(s) falling within the scope of this standard.

NOTE In addition to any specific clauses relating to dangerous substances contained in this standard, there may be other requirements applicable to the products falling within its scope (e.g. transposed European legislation and national laws, regulations and administrative provisions). These requirements need also to be complied with, when and where they apply. An informative database of European and national provisions on dangerous substances is available at the Construction web site on EUROPA (accessed through <http://europa.eu.int>).

This Annex ZA has the same scope, in relation to the products covered, as Clause 1 of this standard. This annex establishes the conditions for the CE marking of aspirating smoke detectors intended for the use shown below and identifies the relevant clauses applicable.

Construction Product: Aspirating smoke detector for fire detection and fire alarm systems for buildings.

Intended use: Fire safety.

Table ZA.1 — Relevant clauses

| Essential characteristics | Clauses in this European Standard | Mandated level(s) | Notes |
|---|-----------------------------------|-------------------|-------|
| Nominal activation conditions/sensitivity, response delay (response time) and performance under fire conditions | 5.6, 6.2, 6.3, 6.15 | None | a) |
| Operational reliability | 5.2 to 5.5, 5.7 to 5.12 | | |
| Tolerance to supply voltage | 6.4 | | |
| Durability of operational reliability, Temperature resistance | 6.5, 6.6 | | |
| Durability of operational reliability, Vibration resistance | 6.10, 6.11, 6.12, 6.13 | | |
| Durability of operational reliability, Electrical stability | 6.14 | | |
| Durability of operational reliability, Humidity resistance | 6.7, 6.8 | | |
| Durability of operational reliability, Corrosion resistance | 6.9 | | |
| <p>^{a)} The products covered by this standard are assumed to enter the alarm condition, in an event of fire, before the fire becomes so large as to affect their functioning. There is therefore no requirement to function when exposed to direct attack from fire.</p> | | | |

ZA.2 Procedures for the attestation of conformity of aspirating smoke detectors covered by this standard

ZA.2.1 System of attestation of conformity

The mandate requires that the attestation of conformity system to be applied shall be that shown in Table ZA.2.

Table ZA.2 — Attestation of conformity system

| Product | Intended use | Levels or classes | Attestation of conformity system |
|---|--------------|-------------------|----------------------------------|
| Fire detection/fire alarm: Aspirating smoke detector | Fire safety | None | 1 |
| System 1: See CPD Annex III.2.(i), without audit-testing of samples by the notified body. | | | |

ZA.2.2 Evaluation of conformity

ZA.2.2.1 General

The evaluation of conformity of the product with the requirements of the European Standard in question shall be demonstrated by:

- a) Tasks to be provided by the manufacturer:
 - 1) factory production control;
 - 2) testing of samples by the manufacturer in accordance with a prescribed test plan;
- b) Tasks to be undertaken under the responsibility of a Notified Product Certification Body:
 - 1) type testing of the product;
 - 2) initial inspection of the factory and factory production control;
 - 3) periodic surveillance, assessment and approval of the factory production control.

NOTE The manufacturer is a natural or legal person, who places the product on the market under his own name. Normally, the manufacturer designs and manufactures the product himself. As a first alternative, he may have it designed, manufactured, assembled, packed, processed or labelled by subcontracting. As a second alternative he may assemble, pack, process, or label ready-made products.

The manufacturer shall ensure:

- that the initial type testing in accordance with this European Standard is initiated and carried out under the responsibility of a notified product certification body; and
- that the product continuously complies with the initial type testing samples, for which compliance with the European Standard in question has been verified.

He shall always retain the overall control and shall have the necessary competence to take the responsibility for the product. The manufacturer shall be fully responsible for the conformity of the product to all relevant regulatory requirements.

ZA.2.2.2 Type testing

ZA.2.2.2.1 Type testing shall be performed to demonstrate conformity with this European Standard.

Type testing of the product shall be carried out in accordance with the clauses shown in Table ZA.1, except as described in ZA.2.2.2.2 and ZA.2.2.2.3.

ZA.2.2.2.2 Tests previously performed, such as type tests for product certification, may be taken into account providing that they were made to the same or a more rigorous test method under the same system of attestation of conformity as required by this standard on the same product or products of similar design, construction and functionality, such that the results are applicable to the product in question.

NOTE Same system of attestation of conformity means testing by an independent third party under the responsibility of a product certification body which is now a notified product certification body.

ZA.2.2.2.3 Where one or more characteristics are the same for products with similar design, construction and functionality then the results of tests for these characteristics on one product may be applied to the other similar product or products.

ZA.2.2.2.4 Test samples shall be representative of the normal production. If the test samples are prototypes, they shall be representative of the intended future production and shall be selected by the manufacturer.

NOTE In the case of prototypes and third party certification, this means that it is the manufacturer not the third party who is responsible for selecting the samples. During the initial inspection of the factory and of the factory production control (see ZA 2.2.3.4), it is verified, that the type tested samples are representative of the product being produced.

ZA.2.2.2.5 All type testing and its results shall be documented in a test report. All test reports shall be retained by the manufacturer for at least ten years after the last date of production of the product to which they relate.

ZA.2.2.3 Factory production control

ZA.2.2.3.1 General

Factory production control (FPC) is the permanent internal control of production exercised by the manufacturer.

All the elements, requirements and provisions adopted by the manufacturer shall be documented in a systematic manner in the form of written policies and procedures. This production control system documentation shall ensure a common understanding of conformity evaluation and enable the achievement of the required product characteristics and the effective operation of the production control system to be checked.

Factory production control therefore brings together operational techniques and all measures allowing maintenance and control of the conformity of the product with its technical specifications. Its implementation may be achieved by controls and tests on measuring equipment, raw materials and constituents, processes, machines and manufacturing equipment and finished products, including material properties in components, and by making use of the results thus obtained.

ZA.2.2.3.2 General requirements

The manufacturer shall establish, document and maintain an FPC system to ensure that the products placed on the market conform to the stated performance characteristics and the samples subjected to type testing.

Where subcontracting takes place, the manufacturer shall retain the overall control of the product and ensure that he receives all the information that is necessary to fulfil his responsibilities according to the European Standard in question. If the manufacturer has part of the product designed, manufactured, assembled, packed, processed and/or labelled by subcontracting, the FPC of the subcontractor may be taken into account, where appropriate for the product in question. The manufacturer who subcontracts all of his activities may in no circumstances pass these responsibilities on to a subcontractor.

The FPC system shall fulfil the requirements as described in the following clauses of EN ISO 9001:2000, where applicable:

- 4.2 except 4.2.1a);
- 5.1 e), 5.5.1, 5.5.2;
- Clause 6;
- 7.1 except 7.1 a), 7.2.3 c), 7.4, 7.5, 7.6;
- 8.2.3, 8.2.4, 8.3, 8.5.2.

The FPC system may be part of an existing quality management system, (e.g. in accordance with EN ISO 9001:2000), the scope of which covers the manufacture of the product.

Where a quality management system is certified in accordance with EN ISO 9001:2000, by a certification body which is now a notified certification body, then the assessment reports of this quality management system should be taken into account with respect to these clauses.

ZA.2.2.3.3 Product specific requirements

The FPC system shall:

- address this European Standard; and
- ensure that the products placed on the market conform to the stated performance characteristics.

The FPC system shall include a product specific FPC or quality plan, which identifies procedures to demonstrate conformity of the product at appropriate stages, i.e.

- a) the controls and tests to be carried out prior to and/or during manufacture according to a frequency laid down; and/or
- b) the verifications and tests to be carried out on finished products according to a frequency laid down.

If the manufacturer uses only finished products, the operations under b) shall lead to an equivalent level of conformity of the product as if normal FPC had been carried out during the production.

If the manufacturer carries out parts of the production himself, the operations under b) may be reduced and partly replaced by operations under a). Generally, the more parts of the production that are carried out by the manufacturer, the more operations under b) may be replaced by operations under a). In any case the operation shall lead to an equivalent level of conformity of the product as if normal FPC had been carried out during the production.

NOTE Depending on the specific case, it can be necessary to carry out the operations referred to under a) and b), only the operations under a) or only those under b).

The operations under a) centre as much on the intermediate states of the product as on manufacturing machines and their adjustment, and measuring equipment etc. These controls and tests and their frequency shall be chosen based on product type and composition, the manufacturing process and its complexity, the sensitivity of product features to variations in manufacturing parameters etc.

The manufacturer shall establish and maintain records that provide evidence that the production has been sampled and tested. These records shall show clearly whether the production has satisfied the defined acceptance criteria and shall be available for at least three years. These records shall be available for inspection.

Where the product fails to satisfy the acceptance measures, the provisions for non-conforming products shall apply, the necessary corrective action shall immediately be taken and the products or batches not conforming shall be isolated and properly identified. Once the fault has been corrected, the test or verification in question shall be repeated.

The results of controls and tests shall be properly recorded. The product description, date of manufacture, test method adopted, test results and acceptance criteria shall be entered in the records under the signature of the person responsible for the control/test. With regard to any control result not meeting the requirements of this European Standard, the corrective measures taken to rectify the situation (e.g. a further test carried out, modification of manufacturing process, discarding or putting right of product) shall be indicated in the records.

Individual products or batches of products and the related manufacturing documentation shall be completely identifiable and retraceable.

ZA.2.2.3.4 Initial inspection of factory and FPC

Initial inspection of FPC shall be carried out when the production process has been finalized and preferably in operation. The factory and FPC documentation shall be assessed to verify that the requirements of ZA.2.2.3.1 and ZA.2.2.3.2 are fulfilled.

In the assessment it shall be verified:

- a) that all resources necessary for the achievement of the product characteristics required by this European Standard are or will be available; and
- b) that the FPC procedures in accordance with the FPC documentation are or will be implemented and followed in practice; and
- c) that the product complies or will comply with the initial type testing samples, for which compliance with this European Standard has been verified.

All locations where final assembly or at least final testing of the relevant product is performed, shall be assessed to verify that the above conditions a) to c) are in place.

If the FPC system covers more than one product, production line or production process, and it is verified that the general requirements are fulfilled when assessing one product, production line or production process, then the assessment of the general requirements does not need to be repeated when assessing the FPC for another product, production line or production process.

Provided that the production process is similar, assessments previously performed in accordance with the provisions of this standard may be taken into account providing that they were made to the same system of attestation of conformity on the same product or products of similar design, construction and functionality, such that the results may be considered applicable to the product in question.

NOTE Same system of attestation of conformity means inspection of FPC by an independent third party under the control of a product certification body which is now a notified product certification body.

All assessment and its results shall be documented in a report.

ZA.2.2.3.5 Periodic surveillance of FPC

Surveillance of the FPC shall be undertaken once a year.

The surveillance of the FPC shall include a review of the quality plan(s) and production processes(s) for each product to determine if any changes have been made since the last assessment or surveillance and the significance of any changes shall be assessed.

Checks shall be made to ensure that the quality plans are still correctly implemented and that the production equipment is still correctly maintained and calibrated.

The records of tests and measurements made during the production process and to finished products shall be reviewed to ensure that the values obtained still correspond with those values for the samples submitted to type testing and that the correct actions have been taken for non-compliant devices.

The surveillance of the FPC may be carried out as part of a surveillance or reassessment of a quality management system (e.g. in accordance with EN ISO 9001:2000).

ZA.2.2.4 Procedure for modifications

If modifications are made to the product, production process or FPC system that could affect any of the product characteristics required by this standard, then all characteristics covered by the clauses shown in Table ZA.1, which may be changed by the modification, shall be subject to type testing or engineering evaluation, except as described in ZA.2.2.2.2 and ZA.2.2.2.3. Where relevant, a re-assessment of the factory and of the FPC system shall be performed for those aspects, which may be affected by the modification.

All assessments and their results shall be documented in a report.

ZA.3 CE Marking and labelling and accompanying documentation

The manufacturer, or his authorised representative established in the EEA, is responsible for the affixing of the CE marking. The CE-marking symbol (in accordance with Directive 93/68/EEC) shall be placed on the product and be accompanied by the number of the EC certificate of conformity and the Notified Body number. If the Notified Body number is included as part of the number on the EC certificate of conformity, then the number of the EC certificate of conformity is sufficient.

The CE marking symbol shall in addition be shown on the accompanying commercial documentation supplemented by:

- a) identification number of the Notified Product Certification Body;
- b) name or identifying mark and registered address of the manufacturer;
- c) last two digits of the year in which the marking was affixed;
- d) number of the EC certificate of conformity;
- e) reference to this European Standard (EN 54-20), its date and any amendments;
- f) description of the construction product (i.e. aspirating smoke detector for fire detection and fire alarm systems for buildings);
- g) response class or classes (e.g. ABC);
- h) other information required by 5.12 or a reference to a document, which shall be uniquely identifiable and available from the manufacturer, containing this information.

NOTE Reference to a separate document is permitted only where the quantity of information would be so large that it could not practically be included in the commercial documentation accompanying the product.

Where the product exceeds the minimum performance levels stated in this standard, and where the manufacturer so desires, the CE marking may be accompanied by an indication of the parameter(s) concerned and the actual test result(s).

Figure ZA.1 shows an example of the CE marking information on the accompanying commercial documentation.

| |
|--|
|  0123 |
| AnyCo Ltd, P.O. Box 21, B1050 06 0123 – CPD – 002 |
| EN 54-20 Aspirating smoke detectors for fire detection and fire alarm systems for buildings Class: A, B and C Technical data: see Doc.123/2006 held by the manufacturer |

Figure ZA.1 — Example of CE marking information in the accompanying commercial documentation

ZA.4 EC certificate and declaration of conformity

The manufacturer, or his authorised representative established in the EEA shall prepare and retain a declaration of conformity, which authorizes the affixing of the CE marking. This declaration shall include:

- name and address of the manufacturer, or his authorized representative established in the EEA, and the place of production;

NOTE 1 The manufacturer may also be the person responsible for placing the product onto the EEA market, if he takes responsibility for CE marking.

- description of the construction product (i.e. aspirating smoke detector for fire detection and fire alarm systems for buildings) and a copy of the information accompanying the CE marking;

NOTE 2 Where some of the information required for the Declaration is already given in the CE marking information, it does not need to be repeated.

- type/model designation of the product;
- provisions to which the product conforms (i.e. Annex ZA of this EN);
- any particular conditions applicable to the use of the product (if necessary);
- name and address (or identification number) of the Notified Product Certification Body;
- name of and position held by the person empowered to sign the declaration on behalf of the manufacturer or of his authorized representative.

The declaration shall contain a certificate of conformity with the following information:

- name and address of the Notified Product Certification Body;
- certificate number;
- name and address of the manufacturer, or his authorized representative established in the EEA;
- description of the construction product (i.e. Aspirating smoke detector for fire detection and fire alarm systems for buildings);
- type/model designation of the product;
- provisions to which the product conforms (i.e. Annex ZA of this EN);
- any particular conditions applicable to the use of the product (if necessary);
- any conditions of validity of the certificate, where applicable;
- name of and position held by the person empowered to sign the certificate.

The above-mentioned declaration and certificate shall be presented (if requested) in the language or languages accepted in the Member State in which the product is to be used.

Bibliography

- [1] EN ISO 9001:2000, Quality management systems - Requirements (ISO 9001:2000)

BSI — British Standards Institution

BSI is the independent national body responsible for preparing British Standards. It presents the UK view on standards in Europe and at the international level. It is incorporated by Royal Charter.

Revisions

British Standards are updated by amendment or revision. Users of British Standards should make sure that they possess the latest amendments or editions.

It is the constant aim of BSI to improve the quality of our products and services. We would be grateful if anyone finding an inaccuracy or ambiguity while using this British Standard would inform the Secretary of the technical committee responsible, the identity of which can be found on the inside front cover.
Tel: +44 (0)20 8996 9000. Fax: +44 (0)20 8996 7400.

BSI offers members an individual updating service called PLUS which ensures that subscribers automatically receive the latest editions of standards.

Buying standards

Orders for all BSI, international and foreign standards publications should be addressed to Customer Services. Tel: +44 (0)20 8996 9001.
Fax: +44 (0)20 8996 7001. Email: orders@bsi-global.com. Standards are also available from the BSI website at <http://www.bsi-global.com>.

In response to orders for international standards, it is BSI policy to supply the BSI implementation of those that have been published as British Standards, unless otherwise requested.

Information on standards

BSI provides a wide range of information on national, European and international standards through its Library and its Technical Help to Exporters Service. Various BSI electronic information services are also available which give details on all its products and services. Contact the Information Centre.
Tel: +44 (0)20 8996 7111. Fax: +44 (0)20 8996 7048. Email: info@bsi-global.com.

Subscribing members of BSI are kept up to date with standards developments and receive substantial discounts on the purchase price of standards. For details of these and other benefits contact Membership Administration.
Tel: +44 (0)20 8996 7002. Fax: +44 (0)20 8996 7001.
Email: membership@bsi-global.com.

Information regarding online access to British Standards via British Standards Online can be found at <http://www.bsi-global.com/bsonline>.

Further information about BSI is available on the BSI website at <http://www.bsi-global.com>.

Copyright

Copyright subsists in all BSI publications. BSI also holds the copyright, in the UK, of the publications of the international standardization bodies. Except as permitted under the Copyright, Designs and Patents Act 1988 no extract may be reproduced, stored in a retrieval system or transmitted in any form or by any means – electronic, photocopying, recording or otherwise – without prior written permission from BSI.

This does not preclude the free use, in the course of implementing the standard, of necessary details such as symbols, and size, type or grade designations. If these details are to be used for any other purpose than implementation then the prior written permission of BSI must be obtained.

Details and advice can be obtained from the Copyright & Licensing Manager.
Tel: +44 (0)20 8996 7070. Fax: +44 (0)20 8996 7553.
Email: copyright@bsi-global.com.