

Lighting columns —

Part 6: Requirements for aluminium lighting columns

The European Standard EN 40-6:2002 has the status of a
British Standard

ICS 77.150.10; 93.080.40

National foreword

This British Standard is the official English language version of EN 40-6:2002. It supersedes BS EN 40-6:2000 which is withdrawn.

EN 40-6:2002 is a candidate “harmonized” European Standard and fully takes into account the requirements of the European Commission mandate M/111, Circulation fixtures, given under the EU Construction Products Directive (89/106/EEC), and intended to lead to CE marking. The date of applicability of EN 40-6:2002 as a “harmonized” European Standard, i.e. the date after which this standard may be used for CE marking purposes, is subject to an announcement in the *Official Journal of the European Communities*.

EN 40-6:2002 is the subject of transitional arrangements agreed under the European Commission mandate. The Member States have agreed a nominal transition period for the co-existence of EN 40-6:2002 and their corresponding national standard(s). It is intended that this period will comprise a nominal nine month period during which any required changes to national regulations are to be made, followed by a further nominal twelve month period for the implementation of CE marking. At the end of this co-existence period, the national standard(s) will be withdrawn. In the UK, there are no corresponding national standards.

The UK participation in its preparation was entrusted by Technical Committee B/509, Road equipment, to Subcommittee B/509/50, Road equipment — Street lighting columns, which has the responsibility to:

- aid enquirers to understand the text;
- present to the responsible international/European committee any enquiries on the interpretation, or proposals for change, and keep the UK interests informed;
- monitor related international and European developments and promulgate them in the UK.

A list of organizations represented on this subcommittee can be obtained on request to its secretary.

Cross-references

The British Standards which implement international or European publications referred to in this document may be found in the *BSI Catalogue* under the section entitled “International Standards Correspondence Index”, or by using the “Search” facility of the *BSI Electronic Catalogue* or of British Standards Online.

This publication does not purport to include all the necessary provisions of a contract. Users are responsible for their correct application.

Compliance with a British Standard does not of itself confer immunity from legal obligations.

Summary of pages

This document comprises a front cover, an inside front cover, the EN title page, pages 23 and a back cover.

The BSI copyright date displayed in this document indicates when the document was last issued.

Amendments issued since publication

Amd. No.	Date	Comments

This British Standard, having been prepared under the direction of the Building and Civil Engineering Sector Policy and Strategy Committee, was published under the authority of the Standards Policy and Strategy Committee on 17 July 2002

© BSI 17 July 2002

ISBN 0 580 40083 2

English version

Lighting columns - Part 6: Requirements for aluminium lighting columns

Candélabres d'éclairage public - Partie 6: Exigences pour les candélabres d'éclairage public en aluminium

Lichtmaste - Teil 6: Anforderungen für Lichtmaste aus Aluminium

This European Standard was approved by CEN on 25 February 2002.

CEN members are bound to comply with the CEN/CENELEC Internal Regulations which stipulate the conditions for giving this European Standard the status of a national standard without any alteration. Up-to-date lists and bibliographical references concerning such national standards may be obtained on application to the Management Centre or to any CEN member.

This European Standard exists in three official versions (English, French, German). A version in any other language made by translation under the responsibility of a CEN member into its own language and notified to the Management Centre has the same status as the official versions.

CEN members are the national standards bodies of Austria, Belgium, Czech Republic, Denmark, Finland, France, Germany, Greece, Iceland, Ireland, Italy, Luxembourg, Malta, Netherlands, Norway, Portugal, Spain, Sweden, Switzerland and United Kingdom.



EUROPEAN COMMITTEE FOR STANDARDIZATION
COMITÉ EUROPÉEN DE NORMALISATION
EUROPÄISCHES KOMITEE FÜR NORMUNG

Management Centre: rue de Stassart, 36 B-1050 Brussels

Contents

	page
Foreword	3
1 Scope	4
2 Normative references	4
3 Terms and definitions	5
4 Materials	6
5 Dimensions	6
6 Design and design verification	6
7 Welding	6
8 Joints	7
9 Protection against mechanical impact	7
10 Internal finish and sharp edges	8
11 Corrosion protection	8
12 Marking	9
13 Conformity control	9
14 Acceptance criteria	13
15 Re-testing	14
16 Performance under vehicle impact – Passive safety	15
Annex A (informative) Corrosion protection for aluminium lighting columns	16
Annex B (informative) Recommendations for storage and installation	17
Annex C (normative) Initial type tests	18
Annex ZA (informative) Clauses of this European Standard addressing the provisions of the EU Construction Products Directive	19

Foreword

This document EN 40-6:2002 has been prepared by Technical Committee CEN/TC 50 "Lighting columns and spigots", the secretariat of which is held by BSI.

This European Standard shall be given the status of a national standard, either by publication of an identical text or by endorsement, at the latest by October 2002, and conflicting national standards shall be withdrawn at the latest by January 2004.

This document supercedes EN 40-6:2000.

This document has been prepared under a mandate given to CEN by the European Commission and the European Free Trade Association and supports essential requirements of EU Directive 89/106/EEC.

For relationship with EU Directive 89/106/EEC see informative annex ZA which is an integral part of this document.

In this standard the annexes A and B are informative and the annex C is normative.

Wherever reference is made to classes, they are considered to be technical classes and not classes according to 3(2) of the Construction Products Directive.

This European Standard is the sixth in a series relating to specifications for lighting columns. At present the Parts of this standard are as follows:

Part 1: Definitions and terms

Part 2: General requirements and dimensions

Part 3: Design and verification

3-1: Specification for characteristic loads

3-2: Verification by testing

3-3: Verification by calculation

Part 4: Requirements for reinforced and prestressed concrete lighting columns

Part 5: Requirements for steel lighting columns

Part 6: Requirements for aluminium lighting columns

Part 7: Requirements for fibre reinforced polymer composite lighting columns

According to the CEN/CENELEC Internal Regulations, the national standards organizations of the following countries are bound to implement this European Standard: Austria, Belgium, Czech Republic, Denmark, Finland, France, Germany, Greece, Iceland, Ireland, Italy,

Luxembourg, Malta, Netherlands, Norway, Portugal, Spain, Sweden, Switzerland and the United Kingdom.

1 Scope

This European Standard specifies requirements for aluminium lighting columns. It includes materials and conformity control. It applies to post top columns not exceeding 20 m height for post top lanterns and to columns with brackets not exceeding 18 m height for side entry lanterns.

This European Standard specifies performance related to the essential requirements of resistance to horizontal (wind) loads and performance under vehicle impact (passive safety) in support of the Essential Requirement No 4 Safety in use measured according to the corresponding test methods included in this European Standard or available in separate European Standards.

It provides for the evaluation of conformity of the products to this European Standard.

2 Normative references

This European Standard incorporates, by dated or undated reference, provisions from other publications. These normative references are cited at the appropriate places in the text, and the publications are listed hereafter. For dated references, subsequent amendments to or revisions of any of these publications apply to this European Standard only when incorporated in it by amendment or revision. For undated references the latest edition of the publication referred to applies (including amendments).

EN 40-1	Lighting columns - Part 1: Definitions and terms.
prEN 40-2:1999	Lighting columns - Part 2: General requirements and dimensions.
EN 40-3-1	Lighting columns - Design and verification - Part 3-1: Specification for characteristic loads.
EN 40-3-2	Lighting columns - Design and verification - Part 3-2: Verification by testing.
prEN 40-3-3	Lighting columns - Design and verification - Part 3-3: Verification by calculation.
EN 288-1	Specification and approval of welding procedures for metallic materials – Part 1: General rules for fusion welding.
EN 288-2	Specification and approval of welding procedures for metallic materials – Part 2: Welding procedures specification for arc welding.

EN 288-4	Specification and approval of welding procedures for metallic materials – Part 4: Welding procedure tests for the arc welding of aluminium and its alloys.
EN 288-8	Specification and approval of welding procedures for metallic materials – Part 8: Approval by a pre-production welding test.
EN 485-3	Aluminium and aluminium alloys - Sheet, strip and plates -Part 3: Tolerances on shape and dimensions for hot rolled products.
EN 485-4	Aluminium and aluminium alloys - Sheet, strip and plates – Part 4: Tolerances on shape and dimensions for cold rolled products.
EN 571-1	Non-destructive testing – Penetrant testing – General principles.
EN 755-7	Aluminium and aluminium alloys - Extruded rod/bar, tube and profiles - Part 7: Seamless tubes, tolerances on dimension and form.
EN 755-8	Aluminium and aluminium alloys - Extruded rod/bar, tube and profiles - Part 8: Porthole tubes, tolerances on dimensions and form.
EN 970	Non-destructive examination of fusion welds - Visual examination.
EN 1011-1	Welding - Recommendations for welding of metallic materials – General guidance for arc welding.
EN 1011-4	Welding - Recommendations for welding of metallic materials - Arc welding of aluminium and aluminium alloys.
EN 1706	Aluminium and aluminium alloys - Castings - Chemical composition and mechanical properties.
EN 10025	Hot rolled products of non-alloy structural steels - Technical delivery conditions.
EN 10204	Metallic products - Types of inspection documents.
EN 12767	Passive safety of support structures for road equipment – Requirements and test methods.
EN 50102	Degrees of protection provided by enclosures for electrical equipment against external mechanical impacts (IK code).

3 Terms and definitions

For the purposes of this European Standard, the terms and definitions given in EN 40-1 apply.

4 Materials

4.1 Aluminium

Materials used shall comply with one of the following standards: EN 485-3, EN 485-4, EN 755-7, EN 755-8 and EN 1706.

Electrolytic action between the foundation bolts and the flange plate shall be prevented by insulation or physical separation.

4.2 Foundation bolts

The minimum mechanical properties of the steel used for foundation bolts shall comply with the requirements of EN 10025 grade S 235 JR.

5 Dimensions

Dimensions shall be in accordance with prEN 40-2.

6 Design and design verification

The column shall be designed to sustain safely the dead loads and the wind loads specified in EN 40-3-1.

The structural design of a lighting column shall be verified either by calculation in accordance with prEN 40-3-3 or by testing in accordance with EN 40-3-2.

7 Welding

7.1 Welding process

Arc welding of aluminium and its alloys shall be in accordance with EN 1011-1 and prEN 1011-4.

7.2 Welding procedures

Welding procedures shall comply with EN 288-1 and EN 288-2.

Written procedures shall be provided for the main structural joints which shall include where relevant the flange plate joint, the base compartment to shaft joint, the door reinforcement, any intermediate column joint, the column to bracket joint and the column seam weld when this is carried out at the time of column manufacture.

Welding procedures shall be approved in accordance with EN 288-8. Pre-production test pieces shall represent the main structural joints.

Welding procedures shall be verified by testing to the requirements of EN 288-4. The welding consumables and procedures used shall be such that the mechanical properties of the as-deposited weld metal will not be less than the respective minimum values required by the designer's specifications for the parent metal to be welded. Verification shall be by a welding co-ordinator.

Procedures shall be reviewed and reapproved where necessary after a period of seven years.

7.3 Welding personnel

Welders shall be tested for each approved procedure to which they shall be required to work (see 7.2). Test pieces shall be as used in the original procedure tests. The approval range shall be in accordance with that for the original procedure.

8 Joints

8.1 General

All joints shall be designed to the requirements specified in clause 6.

NOTE Design of joint details should avoid moisture retention and corrosion.

8.2 Friction joints

When joints are made by drawing parts together to form a friction joint the additional stresses in the connection shall be included in the design.

8.3 Welded joints

Welded joints shall comply with the requirements of clause 7.

9 Protection against mechanical impact

A type test shall be carried out on each type of column base, or part, provided that each end of the part extends at least 0,3 m above and below the door opening. The test shall comply with an impact protection category of IK08 as specified in EN 50102 with the door fitted.

The test equipment shall be either impact pendulum hammer or vertical free fall hammer.

The number of impacts shall be five and shall be applied around the circumference at the mid height of the door. For circular columns these shall be equi-spaced around the remaining circumference excluding the door. For octagonal columns these shall be on each of the adjacent faces excluding the door.

After testing there shall be no indentation greater than 3 mm in depth when measured with a profile gauge. The test validates those products of which the outside diameter (or flat dimension) is equal to or less than the diameter being tested, with the same wall thickness and material strength.

NOTE 1 A type is defined by the shape, the dimensions and thickness and material of the section at mid door height.

NOTE 2 For sections other than circular or octagonal the provisions defined above apply.

10 Internal finish and sharp edges

10.1 Cableways

Cableways shall conform with the requirements of prEN 40-2.

10.2 Access points

All access points used for the installation and fitting of electrical equipment shall be free from rough edges and burrs.

11 Corrosion protection

11.1 Areas of the column for consideration of corrosion protection

For corrosion protection purposes the column is divided into the following areas:

Area A : The exterior surface of the column from the top to a minimum of 0,2 m above ground level or the whole exterior for a column with flange plate.

NOTE 1 The minimum of 0,2 m allows a protection overlap.

Area B : The exterior surface of the ground section including a minimum length of 0,25 m above ground level.

Area C : The interior surface of the column.

NOTE 2 The minimum values in A and B can be increased in countries where snow can cause corrosion problems.

11.2 Corrosion protection measures

Unless otherwise specified the corrosion protection measures given in annex A are recommended.

NOTE Additional measures for corrosion protection at the erection site, do not fall within the scope of this standard.

12 Marking

All columns and brackets shall be clearly and durably marked with:

- a) the name or symbol of the manufacturer;
- b) the year of manufacture;
- c) a reference to this standard;
- d) a unique product code.

The marking shall be formed either in the material or by painting, hard stamping or by a securely fixed label.

NOTE For CE marking and labelling see ZA.3.

13 Conformity control

13.1 Evaluation of conformity

13.1.1 Factory production control

Lighting columns and brackets shall be manufactured under a permanent factory production control system which incorporates the relevant requirements of 13.3 to 13.10 and clauses 14 and 15.

The production control system shall include the following operations:

- the specification and verification of raw materials and constituents;
- the identification of the controlling and checking procedures for the design of new or modified products including the inspection and calibration of equipment;
- the controls and tests to be carried out during manufacture according to a frequency laid down;
- the identification and recording of any instances of non-conformity;
- the procedures for correcting any instances of non-conformity.

The manufacturer shall record the results of the production control system. These records shall include at least the following:

- identification of the product tested;
- the dates of sampling;
- the test methods used;
- the test and inspection results;
- the dates of the tests;
- the identification of the responsible authority within the factory;
- calibration of records.

Where third party surveillance is required the following shall apply:

- the tests necessary to confirm conformity shall be identified;
- the frequency of surveillance tests shall be specified;
- the third party shall be able to undertake verification of the manufacturer's test records;
- records shall be made available to the third party for examination.

13.1.2 Initial type testing

Initial type tests shall conform to annex C.

13.2 Sampling

If required in a particular specification of the customer all lighting columns and/or brackets manufactured shall be submitted for verification. A control sample for verification testing shall be taken randomly from each lot and presented for testing. The minimum number of articles from each lot to form the control sample shall comply with Table 1.

A lot shall consist of columns or brackets of the same nominal height/projection, type and design strength.

Table 1 - Control sample size related to lot size

Number of articles in the lot	Minimum number of articles in the control sample
1 to 3	1
4 to 500	3
501 to 1 200	5

13.3 Dimensional verification

All dimensional parameters given in prEN 40-2 and applicable to the lot shall be verified. These include:

length/projection;

cross-section - at each end and at all changes in cross-section;

door opening;

cable entry slot;

planting depth ;

flange plate dimensions ;

base plate dimensions ;

lantern fixing diameter, length and angle.

Tolerances shall be in accordance with prEN 40-2.

Measurements shall be taken with the column and/or bracket in the horizontal position. Dimensions shall be verified using a measuring tape or gauge which shall be checked for accuracy according to a documented calibration procedure.

13.4 Straightness verification

When any article in the control sample indicates non-compliance, it shall be verified by either or both of the following methods. The column shall be placed horizontally on flat ground or timber bearers with the face showing the greatest curvature at 90° to the vertical plane.

Method A: A line shall be fixed at each end of the column above the maximum bow, tautened, and measurements taken from the line to the column surface with rule or tape measure at a minimum of six locations at or near the apparent position of maximum curvature.

Method B: A gauge as shown in Figure 1 shall be placed with edge 'X' on the suspect surface normal to the axis of the column and moved along that surface at intervals not exceeding 1 m. For polygonal columns the two adjacent surfaces shall also then be checked and for circular columns the surfaces at $15^\circ \pm 5^\circ$ on each side of the line originally checked.

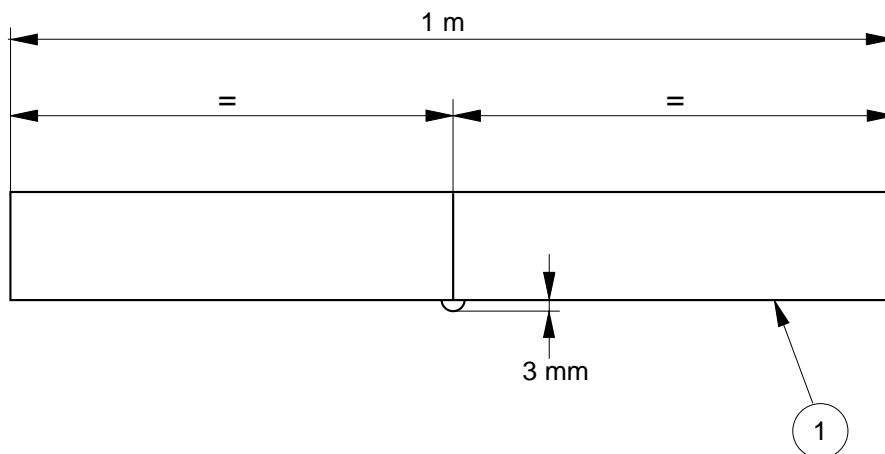

Key
1 Edge 'X'

Figure 1 - Steel gauge for verifying straightness

13.5 Material verification

The material specification shall be verified by a manufacturer's inspection document which accords with EN 10204. Records shall be in place to establish that the verified material(s) have been used in the articles in the lot.

13.6 Weld verification

13.6.1 *Scope of inspection*

Joint configuration shall be inspected after assembly and before welding. The weld preparation and fit-up shall be within the tolerances specified in 7.2.

All welded joints shall be subject to visual inspection prior to the application of any surface protection treatment.

Where specified, or where visual inspection indicates that unacceptable weld discontinuities may be present, the appropriate method of non-destructive testing (NDT) shall be applied to the joints concerned as specified in 13.6.3.

13.6.2 *Inspection personnel*

The manufacturer shall ensure that all personnel selected to carry out inspection have received adequate training. Training records shall be retained and shall be made available for examination when required.

13.6.3 *Non-destructive inspection method*

Visual inspection shall be carried out in accordance with EN 970.

Where, on visual inspection, the presence of surface breaking, cracking or lack of fusion is suspected, penetrant testing in accordance with EN 571 shall be carried out by agreement. The method of inspection shall be appropriate to the types and locations of weld discontinuities being assessed.

13.6.4 *Destructive inspection*

Where verification of the results of non-destructive testing is considered necessary any sectioning and examination criteria shall be agreed.

13.7 Design verification

Design shall be based on the loads specified in EN 40-3-1 and shall be verified either by testing to EN 40-3-2 or by calculation to prEN 40-3-3.

13.8 Verification of corrosion protection

Visual inspection shall be carried out to confirm that protective measures have been carried out on area B and the ground section of area C. (see 11.1)

13.9 Identification verification

The marking shall be checked to confirm correct identification.

13.10 Records

Details of all materials, processes and procedures used and details of sampling and testing and personal training records shall be recorded and retained for a minimum of seven years and made available for examination when required.

14 Acceptance criteria

14.1 General requirement

The lot shall be deemed acceptable, provided all the relevant requirements are met by all the articles in the control sample.

14.2 Dimensions

All applicable dimensions of the checklist given in 13.3 shall be within the specified tolerances.

14.3 Straightness

Method A: When verified by method A in 13.4 no measurement between the line and the column shall exceed that calculated for the column length in accordance with 5.1 of prEN 40-2:1999.

Method B: When verified by method B in 13.4 it shall not be possible for both ends of the gauge to be in contact with the column at any location.

14.4 Material

Verification shall confirm that the material specification and nominal thickness are not less than those specified in the design.

14.5 Welding

14.5.1 *Welding and inspection personnel*

Test results for welders as required in 7.3, and training records as required in 13.6.2 shall be kept current and made available for review on request.

14.5.2 *Welds*

Welding surfaces shall be free from sharp edges, spatter and contaminants.

The throat dimensions of butt welds and the leg length and apparent throat dimensions of fillet welds, as measured by welding gauge and taking into account lack of fit, shall not be less than those specified except that local shortfalls of up to 0,5 mm shall be accepted provided the average over any length is not less than the specified dimensions.

The external toe angle shall not be less than 110°.

The surface of all welds shall be free from cracks and lack of fusion including overlap. Isolated discontinuous porosity will be accepted provided it is not detrimental to the surface protection to be provided.

Undercut shall not result in a section loss of more than 5 % over any 50 mm length of joint, nor shall its depth exceed 0,5 mm or 10 % of the design thickness, whichever is the less.

Work shall be deemed acceptable when the above criteria are met.

14.5.3 Non-destructive inspection

If the additional non-destructive inspection checks reveal satisfactory welds then the lot shall be deemed acceptable.

Where surface breaking porosity, cracking, lack of fusion, lack of penetration or gross internal porosity is confirmed by follow-up penetrant testing in accordance with EN 571-1, the columns shall be deemed to fail. Clause 15 shall apply to the status of the lot.

14.5.4 Destructive inspection

Where destructive inspection to 13.6.4 has been agreed, compliance with 14.5.2 and EN 288-4 shall constitute acceptance.

14.6 Design

A verification of compliance in accordance with 13.7 shall be provided.

14.7 Corrosion protection

A visual inspection shall confirm the presence of protective coating to the ground section of area C and to the whole of area B.

14.8 Identification

Marking shall be legible and comply with the requirements of clause 12 and 13.9.

14.9 Records

Examination shall show that all relevant records are current and available.

15 Re-testing

If any article in the first control sample fails on any of the acceptance criteria 14.2 to 14.9 then two further control samples shall be taken and subjected to re-assessment of the appropriate properties.

If additional samples meet the appropriate requirements of 14.2 to 14.9 then the lot shall be deemed to be acceptable.

If either of the second control samples fails then all items in the lot shall be quarantined until further testing or rectification is agreed.

16 Performance under vehicle impact – Passive safety

When required, the performance of the lighting column regarding passive safety under vehicle impact shall conform to the classification given in EN 12767.

If passive safety is not required the column shall be deemed to be class 0 according to EN 12767.

Annex A
(informative)

Corrosion protection for aluminium lighting columns

The following surface treatment should be carried out:

Area A: None.

Area B: Non-porous, electrically insulating bitumen - containing coating with a minimum layer thickness of $250\mu\text{m}$, or any other material of the required thickness to provide the same degree of protection. The coating should only be applied after degreasing and an appropriate preliminary treatment to ensure adhesion.

Area C: No surface treatment is necessary with the exception of the ground section where protection should be applied as for area B.

NOTE Aluminium alloy columns with the exception of the ground section are customarily delivered in the natural condition.

Annex B

(informative)

Recommendations for storage and installation

It is recommended to avoid storing directly on the ground and in the vicinity of the zones where powdery materials are stored.

The lighting columns should not be stored over a long period without adequate ventilation.

Lighting columns with flange plates should be installed directly on the concrete foundation if this is reasonably smooth and flat. If this is not the case any semi-rigid device capable of ensuring the verticality of the lighting column as well as the correct seating of the support plate can be incorporated. Levelling nuts under the flange should only be used where they have been allowed for in the design.

If the support plate is to be covered it is advisable to make sure that the envisaged material is not aggressive or else install an insulating material between the column base and the coating.

Annex C (normative)

Initial type tests

C.1 When a product shall first demonstrate conformity with this standard, for example when a new product type is developed, and before offering it for sale, appropriate tests shall be carried out to confirm that the properties of the product meet the requirements of this standard.

The tests shall be either physical tests or by calculation. Where tests have previously been done in conformity with the requirements of this standard the results may be taken into account for initial type testing.

Whenever a significant change occurs in the raw material or the production process which could change the properties of the finished product this shall be considered as constituting a new product type.

C.2 The tests shall be the reference tests called up in this standard for the properties selected from the following list, consistent with the intended use of the product:

- a)
 - dimensions;
 - straightness;
 - materials;
 - welding;
 - protection against mechanical impact;

- b)
 - design;
 - corrosion protection;
 - performance under vehicle impact (passive safety).

The results of the initial tests shall be recorded.

Annex ZA (informative)

Clauses of this European Standard addressing the provisions of the EU Construction Products Directive

ZA.1 Scope and relevant characteristics

This European Standard has been prepared under a mandate given to CEN by the European Commission and the European Free Trade Association.

The clauses of this European Standard, shown in this annex, meet the requirements of the mandate M/111 given under the EU Construction Products Directive (89/106/EEC).

Compliance with these clauses confers a presumption of fitness of the construction product covered by this European Standard for its intended use(s).

WARNING: Other requirements and other EU Directives, not affecting the fitness of intended use(s), can be applicable to the construction product falling within the scope of this European Standard.

NOTE 1 In addition to any specific clauses relating to dangerous substances contained in this standard there may be other requirements applicable to the products falling within its scope (e.g. transposed European legislation and national laws, regulations and administrative provisions). In order to meet the provisions of the EU Construction Products Directive these requirements need also to be complied with when and where they apply.

NOTE 2 An informative database of European and national provisions on dangerous substances is available at the Construction web site on EUROPA (*CREATE*, accessed through <http://europa.eu.int>).

Table ZA.1 - Scope and relevant requirement clauses

Construction products: Aluminium lighting columns			
Intended uses: Road lighting columns for circulation areas			
Requirement/ Characteristic	Requirement Clause(s) in this or other European Standard(s):	Mandated level(s) and/or class(es):	Notes:
Resistance to horizontal loads	6 and 8		
Performance under vehicle impact (passive safety)	16		
Durability	11	None	

The requirement on a certain characteristic is not of application in those Member States where there are no regulations for such characteristic. In this case, manufacturers willing to place their products in the market of these Member States are not obliged to determine nor to declare the performance of their products with regard to this characteristic and the option "no performance determined" (NPD) in the information accompanying the CE marking (see ZA.3) may be used.

The NPD option may not be used where the characteristic is subject to a threshold level. Otherwise it may be used when and where the characteristic, for a given intended use, is not subject to regulatory requirements.

ZA.2 Procedure for the attestation of conformity

The system of attestation of conformity of aluminium lighting columns of Table ZA.1, in accordance with the decision of the Commission 96/579/EEC of 24 June 1996 as given in Annex III of the mandate M/111 for Circulation fixtures, is shown in Table ZA.2 for the indicated intended use(s) and relevant level(s) or class(es):

Table ZA.2 - System of attestation of conformity

Product	Intended use	Levels or classes	Attestation of conformity system
Road lighting columns	For circulation areas	None	1
System 1: See CPD Annex III.2.(i) without audit testing of samples			

The attestation of conformity of the aluminium lighting columns in Table(s) ZA.1 shall be based on the evaluation of conformity procedure indicated in Table ZA.3 resulting from application of the clauses of this European Standard indicated therein.

Table ZA.3 - Assignment of evaluation of conformity tasks

Tasks		Content of the task	Evaluation of conformity clauses to apply
Tasks for the manufacturer	Factory production control (F.P.C)	Parameters related to all characteristics of Table ZA.1	13.1.1
	Further testing of samples taken at the factory	All characteristics of Table ZA.1	13.1.1
Tasks for the notified body	Initial type testing	All characteristics of Table ZA.1	13.1.2 (C.1 and C.2b)
	Initial inspection of factory and of F.P.C	Parameters related to all characteristics of Table ZA.1	13.1.1
	Continuous surveillance, assessment and approval of F.P.C.	Parameters related to all characteristics of Table ZA.1	13.1.1

When compliance with the conditions of this annex is achieved, the certification body shall draw up a certificate of conformity (EC Certificate of conformity) with the information indicated below.

The EU Certificate of conformity shall include the following information:

- Name, address and identification number of the certification body;
- Name and address of the manufacturer, or his authorised representative established in the EEA and place of production;
- Description of the product (type, identification, use, copy of information accompanying the CE marking giving indications to identify the characteristics of the product);
- Provisions to which the product conforms (e.g. annex ZA of this European Standard);
- Particular conditions applicable to the use of the product (e.g. provisions for the use of a common cement under certain conditions, etc);
- The number of the certificate;
- Conditions and period of validity of the certificate, where applicable;
- Name of, and position held by, the person empowered to sign the certificate.

This EU Certificate of conformity entitles the manufacturer to affix the CE marking, as described in ZA.3.

In addition the manufacturer shall draw up a declaration of conformity (EC Declaration of conformity) including the following:

- name and address of the manufacturer, or his authorised representative established in the EEA;
- name and address of the certification body;
- description of the product (type, identification, use, ...), and a copy of the information accompanying the CE marking;
- provisions to which the product conforms (e.g. Annex ZA of this EN);
- particular conditions applicable to the use of the product (e.g. provisions for use under certain conditions, etc.);
- number of the accompanying EC Certificate of conformity;
- name of, and position held by, the person empowered to sign the declaration on behalf of the manufacturer or of his authorised representative.

The above mentioned declaration and certificate shall be available in the official language or languages of the Member State(s) of the EU in which the product is to be used.

ZA.3 CE marking and labeling

The manufacturer or his authorised representative established within the EU or EFTA is responsible for the affixing of the CE marking.

The CE conformity symbol shall be in accordance with Directive 93/68/EEC and shall be accompanied by the following information:

- the identification number of the certification body;
- the name or identifying mark of the producer;
- the registered address of the producer;
- the last two digits of the year in which the marking was affixed;
- the number of the EU certificate of conformity;
- a reference to this European Standard;
- description of the product and intended use (code number and name);
- the characteristics of the product (see ZA.1) values to declare:
 - Resistance to horizontal loads: type of design verification (calculation (C) or testing (T)), reference wind velocity, wind area and weight at top, deflection class, terrain category if different to II.
 - Performance under vehicle impact: performance type, backfill type of testing if not standard.

The CE marking and the accompanying information shall be placed in one of the following locations: on the product itself, on a label attached to it, on its packaging or on the accompanying commercial documentation.

Example of CE marking:

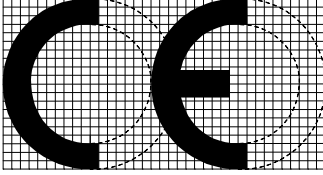
Identification number of notified body Any Company Ltd, PO Box 21, B-1050 00
Certificate number: EN 40-6:2002 Aluminium road lighting columns for circulation areas Code number and name Resistance to horizontal loads: $C-v = 26 \text{ m/s}$; $0,25 \text{ m}^2 - 20 \text{ kg} - 6\%$ Performance under impact (passive safety): Class 0

In addition to any specific information relating to dangerous substances shown above, the product should also be accompanied, when and where required and in the appropriate form, by documentation listing any other legislation on dangerous substances for which compliance is claimed, together with any information required by that legislation.

NOTE European legislation without national derogations need not be mentioned.

BSI — British Standards Institution

BSI is the independent national body responsible for preparing British Standards. It presents the UK view on standards in Europe and at the international level. It is incorporated by Royal Charter.

Revisions

British Standards are updated by amendment or revision. Users of British Standards should make sure that they possess the latest amendments or editions.

It is the constant aim of BSI to improve the quality of our products and services. We would be grateful if anyone finding an inaccuracy or ambiguity while using this British Standard would inform the Secretary of the technical committee responsible, the identity of which can be found on the inside front cover.
Tel: +44 (0)20 8996 9000. Fax: +44 (0)20 8996 7400.

BSI offers members an individual updating service called PLUS which ensures that subscribers automatically receive the latest editions of standards.

Buying standards

Orders for all BSI, international and foreign standards publications should be addressed to Customer Services. Tel: +44 (0)20 8996 9001.
Fax: +44 (0)20 8996 7001. Email: orders@bsi-global.com. Standards are also available from the BSI website at <http://www.bsi-global.com>.

In response to orders for international standards, it is BSI policy to supply the BSI implementation of those that have been published as British Standards, unless otherwise requested.

Information on standards

BSI provides a wide range of information on national, European and international standards through its Library and its Technical Help to Exporters Service. Various BSI electronic information services are also available which give details on all its products and services. Contact the Information Centre.
Tel: +44 (0)20 8996 7111. Fax: +44 (0)20 8996 7048. Email: info@bsi-global.com.

Subscribing members of BSI are kept up to date with standards developments and receive substantial discounts on the purchase price of standards. For details of these and other benefits contact Membership Administration.
Tel: +44 (0)20 8996 7002. Fax: +44 (0)20 8996 7001.
Email: membership@bsi-global.com.

Information regarding online access to British Standards via British Standards Online can be found at <http://www.bsi-global.com/bsonline>.

Further information about BSI is available on the BSI website at <http://www.bsi-global.com>.

Copyright

Copyright subsists in all BSI publications. BSI also holds the copyright, in the UK, of the publications of the international standardization bodies. Except as permitted under the Copyright, Designs and Patents Act 1988 no extract may be reproduced, stored in a retrieval system or transmitted in any form or by any means – electronic, photocopying, recording or otherwise – without prior written permission from BSI.

This does not preclude the free use, in the course of implementing the standard, of necessary details such as symbols, and size, type or grade designations. If these details are to be used for any other purpose than implementation then the prior written permission of BSI must be obtained.

Details and advice can be obtained from the Copyright & Licensing Manager.
Tel: +44 (0)20 8996 7070. Fax: +44 (0)20 8996 7553.
Email: copyright@bsi-global.com.

BSI
389 Chiswick High Road
London
W4 4AL