

BS EN ISO 28927-11:2011



BSI Standards Publication

Hand-held portable power tools — Test methods for evaluation of vibration emission

Part 11: Stone hammers (ISO 28927-11:2011)

bsi.

...making excellence a habit.™

National foreword

This British Standard is the UK implementation of EN ISO 28927-11:2011. Together with BS EN ISO 28927-9:2009, it supersedes BS EN ISO 8662-14:1997, which is withdrawn.

The UK participation in its preparation was entrusted to Technical Committee MCE/8/-/2, Hand-held, non-electric power tools - Safety.

A list of organizations represented on this committee can be obtained on request to its secretary.

This publication does not purport to include all the necessary provisions of a contract. Users are responsible for its correct application.

© BSI 2011

ISBN 978 0 580 64169 5

ICS 13.160; 25.140.10

Compliance with a British Standard cannot confer immunity from legal obligations.

This British Standard was published under the authority of the Standards Policy and Strategy Committee on 31 July 2011.

Amendments issued since publication

Date	Text affected
------	---------------

EUROPEAN STANDARD

NORME EUROPÉENNE

EUROPÄISCHE NORM

EN ISO 28927-11

February 2011

ICS 25.140.10; 13.160

Supersedes EN ISO 8662-14:1996

English Version

Hand-held portable power tools - Test methods for evaluation of vibration emission - Part 11: Stone hammers (ISO 28927-11:2011)

Machines à moteur portatives - Méthodes d'essai pour l'évaluation de l'émission de vibrations - Partie 11: Casse-pierres (ISO 28927-11:2011)

Handgehaltene motorbetriebene Maschinen - Messverfahren zur Ermittlung der Schwingungsemission - Teil 11: Steinbearbeitungsmaschinen (ISO 28927-11:2011)

This European Standard was approved by CEN on 29 January 2011.

CEN members are bound to comply with the CEN/CENELEC Internal Regulations which stipulate the conditions for giving this European Standard the status of a national standard without any alteration. Up-to-date lists and bibliographical references concerning such national standards may be obtained on application to the CEN-CENELEC Management Centre or to any CEN member.

This European Standard exists in three official versions (English, French, German). A version in any other language made by translation under the responsibility of a CEN member into its own language and notified to the CEN-CENELEC Management Centre has the same status as the official versions.

CEN members are the national standards bodies of Austria, Belgium, Bulgaria, Croatia, Cyprus, Czech Republic, Denmark, Estonia, Finland, France, Germany, Greece, Hungary, Iceland, Ireland, Italy, Latvia, Lithuania, Luxembourg, Malta, Netherlands, Norway, Poland, Portugal, Romania, Slovakia, Slovenia, Spain, Sweden, Switzerland and United Kingdom.



EUROPEAN COMMITTEE FOR STANDARDIZATION
COMITÉ EUROPÉEN DE NORMALISATION
EUROPÄISCHES KOMITEE FÜR NORMUNG

Management Centre: Avenue Marnix 17, B-1000 Brussels

Foreword

This document (EN ISO 28927-11:2011) has been prepared by Technical Committee ISO/TC 118 "Compressors and pneumatic tools, machines and equipment" in collaboration with Technical Committee CEN/TC 231 "Mechanical vibration and shock" the secretariat of which is held by DIN.

This European Standard shall be given the status of a national standard, either by publication of an identical text or by endorsement, at the latest by August 2011, and conflicting national standards shall be withdrawn at the latest by August 2011.

Attention is drawn to the possibility that some of the elements of this document may be the subject of patent rights. CEN [and/or CENELEC] shall not be held responsible for identifying any or all such patent rights.

This document supersedes EN ISO 8662-14:1996.

This document has been prepared under a mandate given to CEN by the European Commission and the European Free Trade Association, and supports essential requirements of EU Directive.

For relationship with EU Directive, see informative Annex ZA, which is an integral part of this document.

According to the CEN/CENELEC Internal Regulations, the national standards organizations of the following countries are bound to implement this European Standard: Austria, Belgium, Bulgaria, Croatia, Cyprus, Czech Republic, Denmark, Estonia, Finland, France, Germany, Greece, Hungary, Iceland, Ireland, Italy, Latvia, Lithuania, Luxembourg, Malta, Netherlands, Norway, Poland, Portugal, Romania, Slovakia, Slovenia, Spain, Sweden, Switzerland and the United Kingdom.

Endorsement notice

The text of ISO 28927-11:2011 has been approved by CEN as a EN ISO 28927-11:2011 without any modification.

Annex ZA (informative)

Relationship between this European Standard and the Essential Requirements of EU Directive 2006/42/EC

This European Standard has been prepared under a mandate given to CEN by the European Commission and the European Free Trade Association to provide a means of conforming to Essential Requirements of the New Approach Directive 2006/42/EC on machinery.

Once this standard is cited in the Official Journal of the European Union under that Directive and has been implemented as a national standard in at least one Member State, compliance with the clauses of this standard confers, within the limits of the scope of this standard, a presumption of conformity with the corresponding Essential Requirements of that Directive excerpt ER 2.2.1.1 and associated EFTA regulations.

WARNING — Other requirements and other EU Directives may be applicable to the product(s) falling within the scope of this European Standard.

Contents

Page

Foreword	iv
Introduction.....	vi
1 Scope	1
2 Normative references	1
3 Terms, definitions and symbols	1
3.1 Terms and definitions	2
3.2 Symbols.....	2
4 Basic standards and vibration test codes	2
5 Description of the family of machines	3
6 Characterization of vibration.....	4
6.1 Direction of measurement	4
6.2 Location of measurements.....	4
6.3 Magnitude of vibration	6
6.4 Combination of vibration directions.....	6
7 Instrumentation requirements	7
7.1 General	7
7.2 Mounting of transducers	7
7.3 Frequency weighting filter.....	7
7.4 Integration time.....	7
7.5 Auxiliary equipment	8
7.6 Calibration	8
8 Testing and operating conditions of the machinery.....	8
8.1 General	8
8.2 Operating conditions	8
8.3 Other quantities to be specified.....	9
8.4 Attached equipment, workpiece and task.....	9
8.5 Operator	11
9 Measurement procedure and validity.....	11
9.1 Reported vibration values	11
9.2 Declaration and verification of the vibration emission value	12
10 Test report.....	12
Annex A (informative) Model test report for vibration emission of stone hammers.....	14
Annex B (normative) Determination of uncertainty	16
Bibliography.....	18

Foreword

ISO (the International Organization for Standardization) is a worldwide federation of national standards bodies (ISO member bodies). The work of preparing International Standards is normally carried out through ISO technical committees. Each member body interested in a subject for which a technical committee has been established has the right to be represented on that committee. International organizations, governmental and non-governmental, in liaison with ISO, also take part in the work. ISO collaborates closely with the International Electrotechnical Commission (IEC) on all matters of electrotechnical standardization.

International Standards are drafted in accordance with the rules given in the ISO/IEC Directives, Part 2.

The main task of technical committees is to prepare International Standards. Draft International Standards adopted by the technical committees are circulated to the member bodies for voting. Publication as an International Standard requires approval by at least 75 % of the member bodies casting a vote.

Attention is drawn to the possibility that some of the elements of this document may be the subject of patent rights. ISO shall not be held responsible for identifying any or all such patent rights.

ISO 28927-11 was prepared by Technical Committee ISO/TC 118, *Compressors and pneumatic tools, machines and equipment*, Subcommittee SC 3, *Pneumatic tools and machines*.

This first edition of ISO 28927-11 cancels and replaces ISO 8662-14:1996, of which it constitutes a technical revision. The most important changes are

- vibration measurement in three axes and at both hand positions,
- new transducer positions are used,
- definition of the transducer positions and orientation has been improved,
- needle scalers have been moved to a new part “Scaling hammers and needle scalers” (ISO 28927-9), and
- energy absorber has been deleted and all tools are tested on stone.

ISO 28927 consists of the following parts, under the general title *Hand-held portable power tools — Test methods for evaluation of vibration emission*:

- *Part 1: Angle and vertical grinders*¹⁾
- *Part 2: Wrenches, nutrunners and screwdrivers*²⁾
- *Part 3: Polishers and rotary, orbital and random orbital sanders*³⁾

1) Together with ISO 28927-4, replaces ISO 8662-4, *Hand-held portable power tools — Measurement of vibrations at the handle — Part 4: Grinders*.

2) Replaces ISO 8662-7, *Hand-held portable power tools — Measurement of vibrations at the handle — Part 7: Wrenches, screwdrivers and nut runners with impact, impulse or ratchet action*. All screwdrivers and nutrunners except for one-shot tools now covered.

3) Replaces ISO 8662-8, *Hand-held portable power tools — Measurement of vibrations at the handle — Part 8: Polishers and rotary, orbital and random orbital sanders*.

- Part 4: Straight grinders⁴⁾
- Part 5: Drills and impact drills⁵⁾
- Part 6: Rammers⁶⁾
- Part 7: Nibblers and shears⁷⁾
- Part 8: Saws, polishing and filing machines with reciprocating action and small saws with oscillating or rotating action⁸⁾
- Part 9: Scaling hammers and needle scalers⁹⁾
- Part 10: Percussive drills, hammers and breakers¹⁰⁾
- Part 11: Stone hammers¹¹⁾
- Part 12: Die grinders¹²⁾

4) Together with ISO 29827-1, replaces ISO 8662-4, *Hand-held portable power tools — Measurement of vibrations at the handle — Part 4: Grinders*.

5) Replaces ISO 8662-6, *Hand-held portable power tools — Measurement of vibrations at the handle — Part 6: Impact drills*. Non-impacting drills now covered.

6) Replaces ISO 8662-9, *Hand-held portable power tools — Measurement of vibrations at the handle — Part 9: Rammers*.

7) Replaces ISO 8662-10, *Hand-held portable power tools — Measurement of vibrations at the handle — Part 10: Nibblers and shears*.

8) Replaces ISO 8662-12, *Hand-held portable power tools — Measurement of vibrations at the handle — Part 12: Saws and files with reciprocating action and saws with oscillating or rotating action*.

9) Together with this part of ISO 29827, replaces ISO 8662-14, *Hand-held portable power tools — Measurement of vibrations at the handle — Part 14: Stone-working tools and needle scalers*.

10) To be published. Replaces ISO 8662-2, *Hand-held portable power tools — Measurement of vibrations at the handle — Part 2: Chipping hammers and riveting hammers*, ISO 8662-3, *Hand-held portable power tools — Measurement of vibrations at the handle — Part 3: Rock drills and rotary hammers*, and ISO 8662-5, *Hand-held portable power tools — Measurement of vibrations at the handle — Part 5: Pavement breakers and hammers for construction work*. It also incorporates the Amendments ISO 8662-2:1992/Amd.1:1999, ISO 8662-3:1992/Amd.1:1999 and ISO 8662-5:1992/Amd.1:1999. Chipping and riveting hammers, rock drills and rotary hammers all covered.

11) Together with ISO 29827-9, replaces ISO 8662-14, *Hand-held portable power tools — Measurement of vibrations at the handle — Part 14: Stone-working tools and needle scalers*.

12) Under preparation. Replaces ISO 8662-13, *Hand-held portable power tools — Measurement of vibrations at the handle — Part 13: Die grinders*. It also incorporates the Technical Corrigendum ISO 8662-13:1997/Cor.1:1998.

Introduction

This document is a type-C standard as stated in ISO 12100.

When requirements of this type-C standard are different from those which are stated in type-A or -B standards, the requirements of this type-C standard take precedence over the requirements of the other standards for machines that have been designed and built according to the requirements of this type-C standard.

The vibration test codes for portable hand-held machines given in ISO 28927 (all parts) are based on ISO 20643, which gives general specifications for the measurement of the vibration emission of hand-held and hand-guided machinery. ISO 28927 (all parts) specifies the operation of the machines under type-test conditions and other requirements for the performance of type tests. The structure/numbering of its clauses follows that of ISO 20643.

The basic principle for transducer positioning first introduced in the IEC 60745 series of European standards is followed, representing a deviation from ISO 20643 for reasons of consistency. The transducers are primarily positioned next to the hand in the area between the thumb and the index finger, where they give the least disturbance to the operator gripping the machine.

It has been found that vibrations generated by stone hammers vary considerably in typical use. For stone hammers, impacting action is the prime source of vibration. The variation is largely due to variations in the handling of the machine and the characteristics of the material to work on. Differences in the support of the material also cause differences in vibration. This part of ISO 28927 uses a working process where the machine is used to work on a stone surface. To improve reproducibility of the test, it is important that the material has good support and that inserted tools used are in good condition.

The values obtained are type-test values intended to be representative of the average of the upper quartile of typical vibration magnitudes in real-world use of the machines. However, the actual magnitudes vary considerably from time to time and depend on many factors, including the operator, the task and the inserted tool or consumable. The state of maintenance of the machine itself might also be of importance. Under real working conditions the influences of the operator and process can be particularly important at low magnitudes. It is therefore not recommended that emission values below $2,5 \text{ m/s}^2$ be used for estimating the vibration magnitude under real working conditions. In such cases, $2,5 \text{ m/s}^2$ is the recommended vibration magnitude for estimating the machine vibration.

If accurate values for a specific work place are required, then measurements [according to ISO 5349 (all parts)] in that work situation could be necessary. Vibration values measured in real working conditions can be either higher or lower than the values obtained using this part of ISO 28927.

Higher vibration magnitudes can easily occur in real work situations, caused by the use of excessively worn inserted tools.

The vibration test codes given in ISO 28927 (all parts) supersede those given in ISO 8662 (all parts), which has been replaced by the corresponding parts of ISO 28927 (see Foreword).

NOTE ISO 8662-11, *Hand-held portable power tools — Measurement of vibrations at the handle — Part 11: Fastener driving tools*, could be replaced by a future part of ISO 28927.

Hand-held portable power tools — Test methods for evaluation of vibration emission —

Part 11: Stone hammers

1 Scope

This part of ISO 28927 specifies a laboratory method for measuring hand-transmitted vibration emission at the handles of hand-held stone hammers. It is a type-test procedure for establishing the magnitude of vibration in the gripping areas of a stone hammer when operated in laboratory conditions. It is intended that the results be used to compare different models of the same type of machine.

This part of ISO 28927 is applicable to engraving pens and stone hammers intended for use by stone masons (see Clause 5), driven pneumatically or by other means. It is not applicable to demolition hammers or to chipping hammers primarily intended for use on metal or in construction.

NOTE To avoid confusion with the terms “power tool” and “inserted tool”, “machine” is used hereinafter for the former.

2 Normative references

The following referenced documents are indispensable for the application of this document. For dated references, only the edition cited applies. For undated references, the latest edition of the referenced document (including any amendments) applies.

ISO 2787, *Rotary and percussive pneumatic tools — Performance tests*

ISO 5349, (all parts), *Mechanical vibration — Measurement and evaluation of human exposure to hand-transmitted vibration*

ISO 5391:2003, *Pneumatic tools and machines — Vocabulary*

ISO 17066, *Hydraulic tools — Vocabulary*

ISO 20643:2005, *Mechanical vibration — Hand-held or hand-guided machinery — Principles for evaluation of vibration emission*

EN 12096, *Mechanical vibration — Declaration and verification of vibration emission values*

3 Terms, definitions and symbols

For the purposes of this document, the terms and definitions given in ISO 5391, ISO 17066 and ISO 20643 and the following apply.

3.1 Terms and definitions

3.1.1

stone hammer

percussive machine for carving and chipping stone

NOTE Adapted from ISO 5391:2003, definition 2.2.6.

3.1.2

chisel

inserted tool with a straight edge, intended for carving stone

3.1.3

bush

inserted tool with teeth for levelling the surface of a stone workpiece and/or applying a pattern to the surface of the stone

3.1.4

bush hammering

mechanical process which produces textured surfaces

NOTE Textures vary from subtle to rough.

3.2 Symbols

Symbol	Description	Unit
a_{hw}	root-mean-square (r.m.s.) single-axis acceleration value of the frequency-weighted hand-transmitted vibration	m/s ²
a_{hv}	vibration total value of frequency-weighted r.m.s. acceleration; root sum of squares of the a_{hw} values for the three measured axes of vibration	m/s ²
$\overline{a_{hv}}$	arithmetic mean value of a_{hv} values of runs for one operator for one hand position	m/s ²
a_h	arithmetic mean value of $\overline{a_{hv}}$ values for all operators for one hand position	m/s ²
$\overline{a_h}$	arithmetic mean value of a_h values for one hand position on several machines	m/s ²
a_{hd}	declared vibration emission value	m/s ²
s_{n-1}	standard deviation for a test series (for a sample, s)	m/s ²
σ_R	standard deviation of reproducibility (for a population, σ)	m/s ²
C_v	coefficient of variation for a test series	
K	uncertainty	m/s ²

4 Basic standards and vibration test codes

This part of ISO 28927 is based on the requirements of ISO 20643 and corresponds to its structure in respect of clause subjects and numbering, except for the annexes.

Annex A presents a model test report and Annex B the means for determining the uncertainty, K .

5 Description of the family of machines

This part of ISO 28927 applies to stone hammers, which are usually pneumatically powered straight machines although some have a “D” handle or pistol grip handle. Some are fitted with spring-loaded sleeves to reduce vibration transmitted to the operator's hand. The chisel is generally not fixed in the hammer but held by the operator. Some chisels also have sleeves, attached either to the hammer or to the chisel with spring-loading to reduce vibration.

This part of ISO 28927 is applicable to hand-held power-driven portable stone hammers.

It is not applicable to demolition hammers or to chipping hammers primarily intended for use on metal or in construction.

Figures 1 to 3 show examples of stone hammers as specified in this part of ISO 28927. Figure 4 is an example of a sleeved chisel intended to be used when the chisel needs to be guided using the left hand.

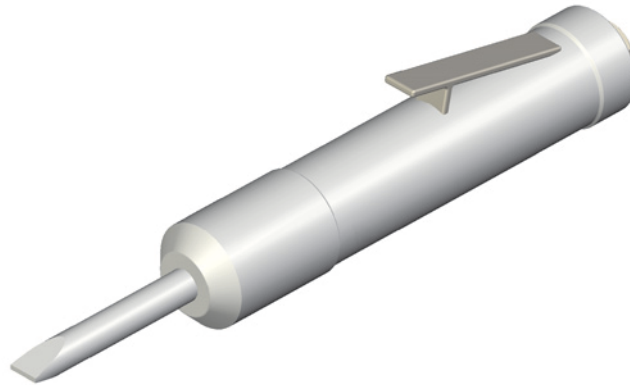

Figure 1 —Straight hammer

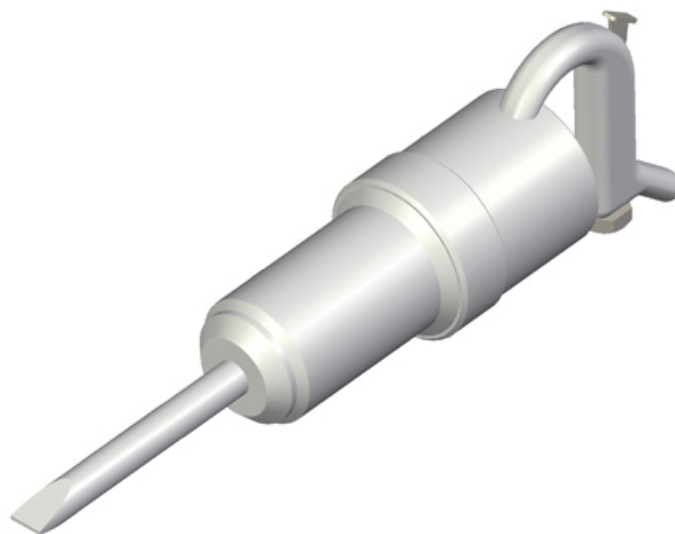

Figure 2 —Hammer with open or closed bow grip



Figure 3 —Pistol grip hammer

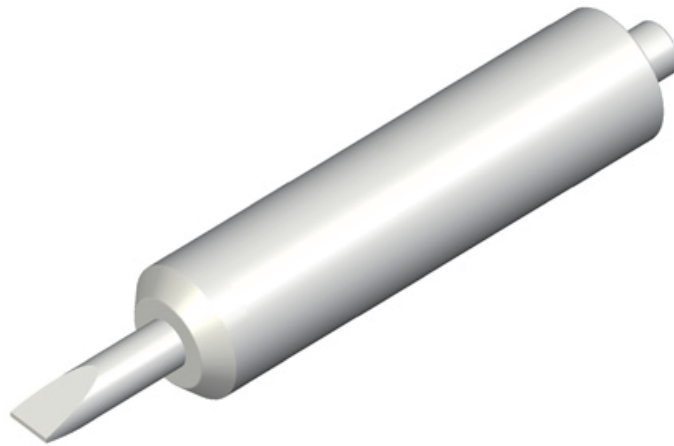

Figure 4 —Sleeved chisel

6 Characterization of vibration

6.1 Direction of measurement

The vibration transmitted to the hand shall be measured and reported for three directions of an orthogonal coordinate system. At each hand position, the vibration shall be measured simultaneously in the three directions shown in Figures 5 to 8.

6.2 Location of measurements

Measurements shall be made at the gripping zones, where the operator normally holds the machine and applies the feed force. For machines intended for one-handed operation, it is only necessary to measure at a single point.

The prescribed transducer location shall be as close as possible to the hand between the thumb and index finger. This shall apply to both hand positions, with the machine held as in normal operation. Whenever possible, measurements shall be made at the prescribed locations.

A secondary location is defined as being on the side of, and as close as possible to, the inner end of the handle where the prescribed location is found. If the prescribed location of the transducer cannot be used, this secondary location shall be used instead.

The prescribed or secondary locations shall also be used on anti-vibration handles.

Figures 5 to 8 show the prescribed and secondary locations and measurement directions for the hand positions normally used for the different types of machines in this family.

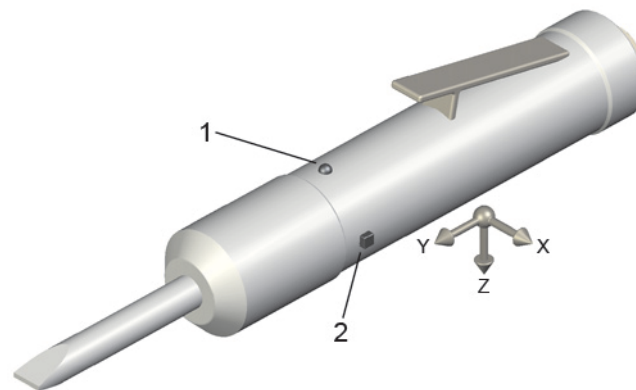

Key

- 1 prescribed location
- 2 secondary location

Figure 5 —Straight hammer

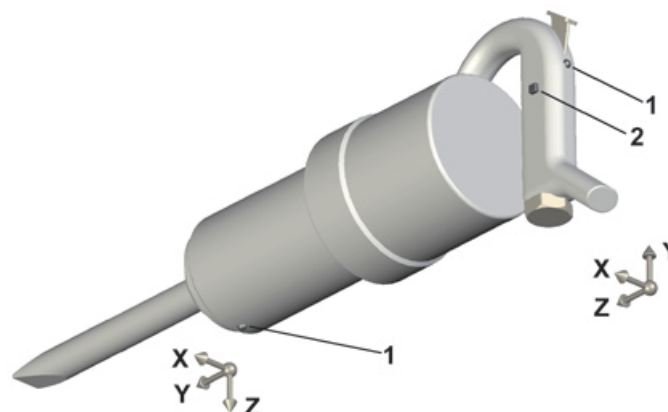

Key

- 1 prescribed location
- 2 secondary location

Figure 6 —Hammer with open or closed bow grip

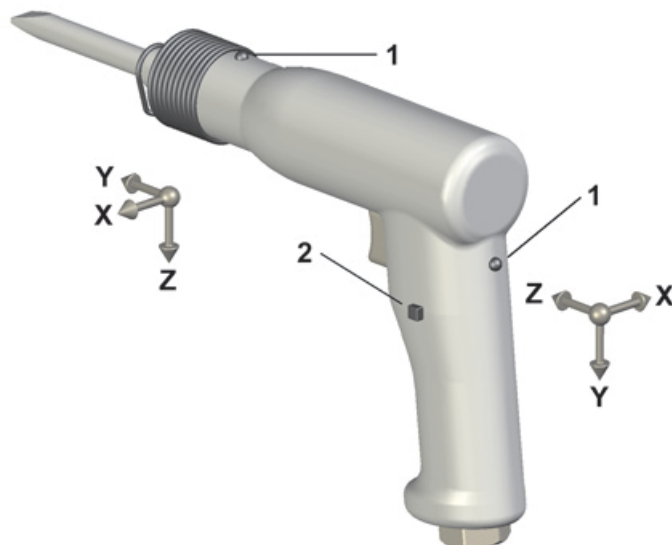

Key

- 1 prescribed location
- 2 secondary location

Figure 7 —Pistol grip hammer

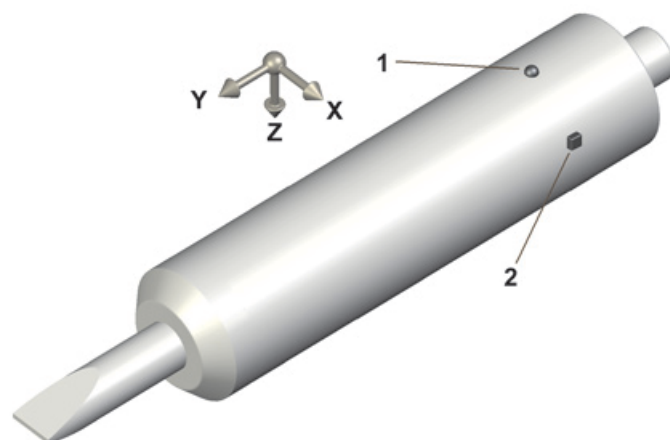

Key

- 1 prescribed location
- 2 secondary location

Figure 8 —Sleeved chisel

6.3 Magnitude of vibration

The magnitude of vibration shall be in accordance with ISO 20643:2005, 6.3.

6.4 Combination of vibration directions

The vibration total value in accordance with ISO 20643:2005, 6.4, shall be reported for both hand positions, as applicable. It is acceptable to report and carry out tests on the hand position having the highest reading. The vibration total value at that hand position shall be at least 30 % higher than at the other. This result may be obtained during a preliminary test carried out by a single operator during five test runs.

To obtain the vibration total value, a_{hv} , for each test run, the results in each direction shall be combined using Equation (1):

$$a_{hv} = \sqrt{a_{hwx}^2 + a_{hwy}^2 + a_{hwz}^2} \quad (1)$$

The a_{hv} value for each operator shall be calculated as the arithmetic mean of the a_{hv} values for the five tests.

For each hand position, the results from the three operators should be combined to one value, a_h , using the arithmetic mean of the three a_{hv} values.

7 Instrumentation requirements

7.1 General

The instrumentation shall be in accordance with ISO 20643:2005, 7.1.

7.2 Mounting of transducers

7.2.1 Specification of transducer

The specification of the transducer given in ISO 20643:2005, 7.2.1, applies.

The total mass of the transducers and mounting device shall be small enough, compared with that of the machine, handle, etc., so as not to influence the measurement result.

This is particularly important for low-mass plastic handles (covered in ISO 5349-2).

7.2.2 Fastening of transducers

The transducer or mounting block used shall be rigidly attached to the surface of the handle.

If three single-axis transducers are used, these shall be attached to three sides of a suitable mounting block.

For the two axes aligned parallel to the vibrating surface, the measurement axes of the two transducers (or the two transducer elements in a triaxial transducer) shall be a maximum of 10 mm from the surface.

It is normally necessary to use mechanical filters for measurements in accordance with this part of ISO 28927 to prevent d.c. shifts. At the time of publication of this part of ISO 28927, it is still good practice to use three accelerometers, one for each direction, mounted on a block, each with its own mechanical filter. However, some triaxial accelerometers may be suitable. It is also good practice to be observant of low-frequency components in the measurement signal below the blow frequency. Such components are often early signs of d.c. shifts or instrument overload in the high-frequency region.

7.3 Frequency weighting filter

Frequency weighting shall be in accordance with ISO 5349-1.

7.4 Integration time

The integration time shall be in accordance with ISO 20643:2005, 7.4. The integration time for each test run shall be at least 8 s, so as to be consistent with the duration of machine operation defined in Clause 8.

7.5 Auxiliary equipment

For pneumatic machines, the air pressure shall be measured using a pressure gauge with an accuracy equal to or better than 0,1 bar¹³⁾.

For hydraulic machines, the flow shall be measured using a flow meter with an accuracy equal to or better than 0,25 l/min.

For electrical machines, the voltage shall be measured using a volt meter with an accuracy equal to or better than 3 % of the actual value.

7.6 Calibration

The specifications for calibration given in ISO 20643:2005, 7.6, apply.

8 Testing and operating conditions of the machinery

8.1 General

Measurements shall be carried out on new, properly serviced and lubricated machines. If, for some types of machines, a warming-up period is specified by the manufacturer, this shall be undertaken prior to the start of the test.

Machines intended for one-handed operation shall be held using only one hand during testing. Measurements shall be made in one location only and for the hand position used. During measurement, a support handle shall not be mounted.

8.2 Operating conditions

8.2.1 Pneumatic machines

During testing, the machine shall operate at the rated pressure in accordance with the manufacturer's specifications. The operation shall be stable and smooth. The air pressure shall be measured and reported.

Air shall be supplied to the machine by means of a hose of the diameter recommended by the machine manufacturer. The test hose shall be attached to the machine via a threaded hose connector, preferably the one supplied with the machine. The length of the test hose shall be 3 m. The test hose shall be secured with a hose clip. Quick couplings shall not be used, since their mass influences the vibration magnitude.

The air pressure of pneumatically powered machines shall be measured in accordance with ISO 2787 and maintained as specified by the manufacturer. During testing, the air pressure measured immediately before the test hose shall not drop by more than 0,2 bar below the pressure recommended by the manufacturer.

8.2.2 Hydraulic machines

During testing, the machine shall be operated at the rated power supply, i.e. the rated flow, and shall be used in accordance with the manufacturer's specifications. The operation shall be stable and smooth. A warming-up period of about 10 min should be allowed before starting the measurements. The flow shall be measured and reported.

13) 1 bar = 0,1 MPa = 0,1 N/mm² = 10⁵ N/m².

8.2.3 Electrical machines

During testing, the machine shall be operated at the rated voltage, and shall be used in accordance with the manufacturer's specifications. The operation shall be stable and smooth. The voltage shall be measured and reported.

8.3 Other quantities to be specified

The power supply: air pressure, hydraulic flow and voltage used shall be measured and reported.

8.4 Attached equipment, workpiece and task

The hammer shall be fitted with an inserted tool of the type that is most commonly used with that hammer. For larger hammers, this may be a bush machine; for smaller hammers, it may be a flat chisel. Where more than one type of inserted tool is commonly used with the hammer, the lightest one shall be selected.

If the hammer is intended for use with a conventional chisel or bush (without a sleeve) and this is in contact with the operator's hand in intended use, it is not usually practicable to measure the vibration on the chisel or bush. However, it is likely that the vibration at this hand position would be much greater than that measured on the hammer. In such cases, a vibration emission value of "greater than 30 m/s²" shall be declared (see Clause 9) and measurement is not required.

The hammer shall be operated on stone with an apparent specific weight ranging from 25,0 kN/m³ to 32,5 kN/m³ (apparent density 2 500 kg/m³ to 3 200 kg/m³), such as granite, marble and hard limestone. The workpiece shall be a block of stone with a flat upper surface. The minimum dimensions shall be 500 mm (length), 250 mm (width) and 250 mm (height). The workpiece shall be mounted on a rigid heavy base with no resonances below 1 kHz. The height of the workpiece shall be such that the operator can adopt a comfortable, upright posture to carve a groove in the upper surface of the stone. For example, for an operator measuring 1,70 m in height, a workpiece height of approximately 1,20 m may be suitable.

In each test run, the operator shall carve a groove along the upper surface of the workpiece. The operation of the hammer shall be stable and smooth and shall allow a measurement period of least 8 s. The angle between the main axis of the machine and the stone surface shall be appropriate for the operation and similar to that used in real work. (For bush machines this is approximately 90°.)

The feed force applied shall be appropriate for normal, efficient operation of the hammer, and for machines with spring-loaded sleeves or suspension systems; it shall allow such systems to operate correctly, as recommended by the manufacturer.

NOTE The test in the previous test code, ISO 8662-14:1996, used an artificial operation with an energy absorber. The vibration was measured only on the hammer and only in one direction. This did not allow measurement at the chisel hand position, which is generally the position of greater vibration.

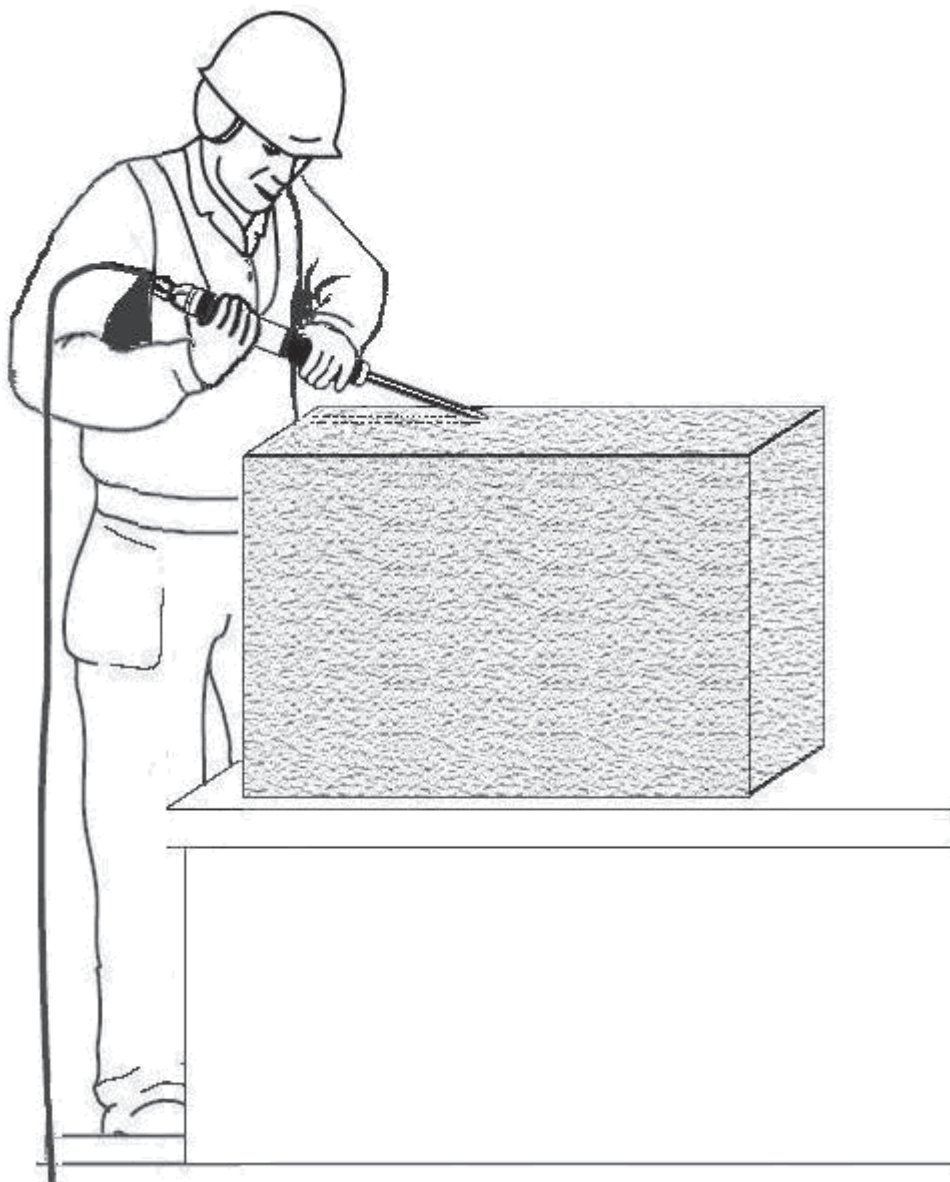

Figure 9 —Working position of operator —Stone hammer

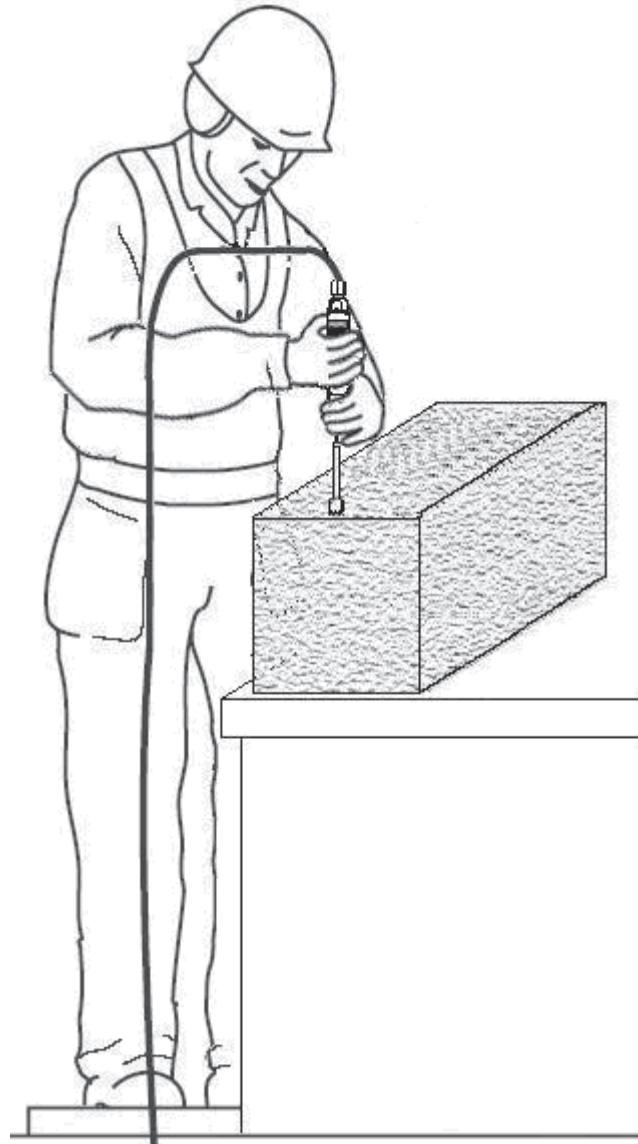

Figure 10 —Working position of operator —Bush hammer

8.5 Operator

Three different operators shall operate the machine during testing. The vibration of the machine is influenced by the operators. They shall, therefore, be skilled stone masons who are able to hold and operate the machine correctly.

9 Measurement procedure and validity

9.1 Reported vibration values

Three series of five consecutive tests shall be carried out on each machine tested, using a different operator for each series.

The values (see also 6.4) should be reported using the model test report shown in Annex A.

The coefficient of variation, C_v , and the standard deviation, s_{n-1} , shall be calculated for each hand position for each of the three operators. The C_v of a test series is defined as the ratio of s_{n-1} to the mean value of the series:

$$C_v = \frac{s_{n-1}}{\overline{a_{hv}}} \quad (2)$$

with s_{n-1} identical to s_{rec} (see Annex B) and where the standard deviation of the i th value, a_{hvi} , is given as Equation (3):

$$s_{n-1} = \sqrt{\frac{1}{n-1} \sum_{i=1}^n (a_{hvi} - \overline{a_{hv}})^2} \quad (3)$$

where

$\overline{a_{hv}}$ is the mean value of the series, in metres per square second;

n is equal to five, the number of measured values.

If C_v is greater than 0,15 or s_{n-1} is greater than 0,3 m/s², then the measurements shall be checked for error before data are accepted.

9.2 Declaration and verification of the vibration emission value

The $\overline{a_{hv}}$ value for each operator shall be calculated as the arithmetic mean of the a_{hv} values for the five test runs.

For each hand position, the result from the three operators should be combined into one value, a_h , using the arithmetic mean of the three $\overline{a_{hv}}$ values.

For tests using only one machine, the declared value, a_{hd} , is the highest of the a_h values reported for the two hand positions.

For tests using three or more machines, $\overline{a_h}$ values for each hand position shall be calculated as the arithmetic mean of the a_h values for the different machines on that hand position. The declared value, a_{hd} , is the highest of the $\overline{a_h}$ values reported for the two hand positions.

Both the declared value, a_{hd} , and the uncertainty, K , shall be presented with the precision determined in EN 12096. The value a_{hd} is to be given in metres per square second and presented by using two and a half significant digits for numbers starting with 1 (e.g. 1,20 m/s², 14,5 m/s²); otherwise two significant digits are sufficient (e.g. 0,93 m/s², 8,9 m/s²). The value of the uncertainty, K , shall be presented with the same number of decimals as a_{hd} .

K shall be determined in accordance with EN 12096, based on the standard deviation of reproducibility, σ_R . The value of K shall be calculated in accordance with the information given in Annex B.

10 Test report

The following information shall be given in the test report:

- reference to this part of ISO 28927, i.e. ISO 28927-11:2010;
- name of the measuring laboratory;
- date of measurement and name of the person responsible for the test;

- d) specification of the hand-held machine (manufacturer, type, serial number, etc.);
- e) declared emission value, a_{hd} , and uncertainty, K ;
- f) attached or inserted tools;
- g) energy supply (air pressure/input voltage, etc., as applicable);
- h) instrumentation (accelerometer mass, integrators, recording system hardware, software, etc.);
- i) position and fastening of transducers, measuring directions and individual vibration values;
- j) operating conditions as specified in 8.2 and 8.3;
- k) detailed results of the test (see Annex A).

If transducer positions or measurements other than those specified in this part of ISO 28927 are used, they shall be clearly defined and an explanation of the reason for the change in the position of the transducer shall be inserted in the test report.

Annex A (informative)

Model test report for vibration emission of stone hammers

See Tables A.1 and A.2.

Table A.1 —General information

The test has been carried out in accordance with ISO 28927-11: <i>Hand-held portable power tools — Test methods for evaluation of vibration emission —Part 11: Stone hammers</i>	
Tester:	
Measured by (company/labortatory):	Tested by: Reported by: Date:
Test object and declared value:	
Machine tested (power supply and machine type, manufacturer, machine model and name, mass):	Declared vibration emission value, a_{hd} , and uncertainty, K :
Measuring equipment:	
Transducers (manufacturer, type, positioning, fastening method, photos, mechanical filters, if used):	
Vibration instrumentation:	Auxiliary equipment:
Operating and test conditions, and results:	
Test conditions (see 8.2 to 8.4; material used, workpiece, operator posture and hand position):	
Power supply (air pressure, hydraulic flow, voltage):	Any other quantities to report:

Table A.2 — Measurement results for one machine

Date:		Machine type:				Serial number:									
Test	Operator	Test run	Main handle (hand position 1)				Support handle (hand position 2)								
			a_{hwX}	a_{hwY}	a_{hwZ}	a_{hv}	$\overline{a_{hv}}$	s_{n-1}	C_v	$\overline{a_{hv}}$	s_{n-1}	C_v			
1	1	1													
2	1	2													
3	1	3													
4	1	4													
5	1	5													
6	2	1													
7	2	2													
8	2	3													
9	2	4													
10	2	5													
11	3	1													
12	3	2													
13	3	3													
14	3	4													
15	3	5													
			a_h for hand position 1:				a_h for hand position 2:								
			s_R for hand position 1:				s_R for hand position 2:								

NOTE The a_{hv} and $\overline{a_{hv}}$ values are calculated according to 6.4 and 9.2, s_{n-1} and C_v are calculated according to 9.1, and s_R is calculated according to Annex B.

Annex B (normative)

Determination of uncertainty

B.1 General

The uncertainty value, K , represents the uncertainty of the declared vibration emission value, a_{hd} , and, in the case of batches, production variations of machinery. It is expressed in metres per square second.

The sum of a_{hd} and K indicates the limit below which the vibration emission value of a single machine, and/or a specified large proportion of the vibration emission values of a batch of machines, are stated to lie when the machines are new.

B.2 Tests on single machines

For tests made on only a single machine, K shall be given as

$$K = 1,65\sigma_R$$

where σ_R is the standard deviation of reproducibility, estimated by the value s_R , given by

$$a) \quad s_R = \sqrt{s_{rec}^2 + s_{op}^2}$$

or

$$b) \quad s_R = 0,06a_{hd} + 0,3$$

whichever is the greater.

NOTE 1 Equation b) is empirical, based on experience giving a lower limit for s_R .

The calculations are performed on the hand position giving the highest value of a_h , where

$\overline{s_{rec}^2}$ is the arithmetic mean value of the standard deviation from the results of five tests, s_{recj} , for operator j , identical to s_{n-1} according to 9.1, and with the s_{recj}^2 value for each operator calculated using:

$$s_{recj}^2 = \frac{1}{n-1} \sum_{i=1}^n (a_{hvj} - \overline{a_{hv}})^2$$

where

n is equal to five, the number of measured values;

a_{hvj} is the vibration total value for the i th test with the j th operator;

$\overline{a_{hv}}$ is the average vibration total value of measurements on the j th operator;

s_{op} is the standard deviation of the results from the three operators, i.e.

$$s_{op}^2 = \frac{1}{m-1} \sum_{j=1}^m (\overline{a_{hvj}} - a_h)^2$$

where

m is equal to three, i.e. the number of operators;

$\overline{a_{hvj}}$ is the average vibration value from the j th operator (average of five tests);

a_h is the average vibration value from all three operators;

a_{hd} is the highest of the a_h values reported for the two hand positions.

NOTE 2 The value of s_R is an estimate of the standard deviation of reproducibility of testing performed at different test centres. Since, at the time of publication, there is no information on reproducibility for the tests defined in this part of ISO 28927, the value for s_R is based on the repeatability of the test for individual test subjects and across the different test subjects, according to EN 12096.

B.3 Tests on batches of machines

For tests on three or more machines, the K value shall be given as

$$K = 1,5\sigma_t$$

where σ_t is estimated by the value s_t , given by

a) $s_t = \sqrt{s_R^2 + s_b^2}$

or

b) $s_t = 0,06a_{hd} + 0,3$

whichever is the greater.

The calculations are performed on the hand position giving the highest value of $\overline{a_h}$ and where

s_R^2 is the mean value of s_R^2 for the different machines in the batch, with the s_R value for each machine calculated using B.2 a) above;

s_b is the standard deviation of the test results for individual machines, i.e.

$$s_b^2 = \frac{1}{p-1} \sum_{l=1}^p (a_{hl} - \overline{a_h})^2$$

where

a_{hl} is the single-machine emission for one hand position on the l th machine;

$\overline{a_h}$ is the mean value of the single-machine emissions for one hand position;

a_{hd} is the highest of the $\overline{a_h}$ values reported for the two hand positions;

p is the number of machines tested (≥ 3).

Bibliography

- [1] ISO 12100, *Safety of machinery — General principles for design — Risk assessment and risk reduction*
- [2] IEC 60745 (all parts), *Hand-held motor-operated electric tools — Safety*

British Standards Institution (BSI)

BSI is the national body responsible for preparing British Standards and other standards-related publications, information and services.

BSI is incorporated by Royal Charter. British Standards and other standardization products are published by BSI Standards Limited.

About us

We bring together business, industry, government, consumers, innovators and others to shape their combined experience and expertise into standards-based solutions.

The knowledge embodied in our standards has been carefully assembled in a dependable format and refined through our open consultation process. Organizations of all sizes and across all sectors choose standards to help them achieve their goals.

Information on standards

We can provide you with the knowledge that your organization needs to succeed. Find out more about British Standards by visiting our website at bsigroup.com/standards or contacting our Customer Services team or Knowledge Centre.

Buying standards

You can buy and download PDF versions of BSI publications, including British and adopted European and international standards, through our website at bsigroup.com/shop, where hard copies can also be purchased.

If you need international and foreign standards from other Standards Development Organizations, hard copies can be ordered from our Customer Services team.

Subscriptions

Our range of subscription services are designed to make using standards easier for you. For further information on our subscription products go to bsigroup.com/subscriptions.

With **British Standards Online (BSOL)** you'll have instant access to over 55,000 British and adopted European and international standards from your desktop. It's available 24/7 and is refreshed daily so you'll always be up to date.

You can keep in touch with standards developments and receive substantial discounts on the purchase price of standards, both in single copy and subscription format, by becoming a **BSI Subscribing Member**.

PLUS is an updating service exclusive to BSI Subscribing Members. You will automatically receive the latest hard copy of your standards when they're revised or replaced.

To find out more about becoming a BSI Subscribing Member and the benefits of membership, please visit bsigroup.com/shop.

With a **Multi-User Network Licence (MUNL)** you are able to host standards publications on your intranet. Licences can cover as few or as many users as you wish. With updates supplied as soon as they're available, you can be sure your documentation is current. For further information, email bsmusales@bsigroup.com.

BSI Group Headquarters

389 Chiswick High Road London W4 4AL UK

Revisions

Our British Standards and other publications are updated by amendment or revision.

We continually improve the quality of our products and services to benefit your business. If you find an inaccuracy or ambiguity within a British Standard or other BSI publication please inform the Knowledge Centre.

Copyright

All the data, software and documentation set out in all British Standards and other BSI publications are the property of and copyrighted by BSI, or some person or entity that owns copyright in the information used (such as the international standardization bodies) and has formally licensed such information to BSI for commercial publication and use. Except as permitted under the Copyright, Designs and Patents Act 1988 no extract may be reproduced, stored in a retrieval system or transmitted in any form or by any means – electronic, photocopying, recording or otherwise – without prior written permission from BSI. Details and advice can be obtained from the Copyright & Licensing Department.

Useful Contacts:

Customer Services

Tel: +44 845 086 9001

Email (orders): orders@bsigroup.com

Email (enquiries): cservices@bsigroup.com

Subscriptions

Tel: +44 845 086 9001

Email: subscriptions@bsigroup.com

Knowledge Centre

Tel: +44 20 8996 7004

Email: knowledgecentre@bsigroup.com

Copyright & Licensing

Tel: +44 20 8996 7070

Email: copyright@bsigroup.com



...making excellence a habit.™