

BS EN ISO 28927-10:2011

Incorporating corrigendum July 2011



BSI Standards Publication

Hand-held portable power tools — Test methods for evaluation of vibration emission

Part 10: Percussive drills, hammers and breakers (ISO 28927-10:2011)

bsi.

...making excellence a habit.™

National foreword

This British Standard is the UK implementation of EN ISO 28927-10:2011. It supersedes BS EN 28662-2:1995, BS EN 28662-3:1995, and BS EN 28662-5:1995, which are withdrawn.

The UK participation in its preparation was entrusted to Technical Committee MCE/8/-/2, Hand-held, non-electric power tools - Safety.

A list of organizations represented on this committee can be obtained on request to its secretary.

This publication does not purport to include all the necessary provisions of a contract. Users are responsible for its correct application.

© BSI 2011

ISBN 978 0 580 75756 3

ICS 13.160; 25.140.01

Compliance with a British Standard cannot confer immunity from legal obligations.

This British Standard was published under the authority of the Standards Policy and Strategy Committee on 31 May 2011.

Amendments/corrigenda issued since publication

Date	Text affected
31 July 2011	Implementation of CEN correction notice May 2011: correction of supersession details in CEN Foreword

EUROPEAN STANDARD

EN ISO 28927-10

NORME EUROPÉENNE

EUROPÄISCHE NORM

April 2011

ICS 13.160; 25.140.10

English Version

**Hand-held portable power tools - Test methods for evaluation of
vibration emission - Part 10: Percussive drills, hammers and
breakers (ISO 28927-10:2011)**

Machines à moteur portatives - Méthodes d'essai pour
l'évaluation de l'émission de vibrations - Partie 10:
Marteaux à percussion, perforateurs et brise-béton (ISO
28927-10:2011)

Handgehaltene motorbetriebene Maschinen -
Messverfahren zur Ermittlung der Schwingungsemission -
Teil 10: Bohrhämmer, Schlaghämmer und
Aufbruchhämmer (ISO 28927-10:2011)

This European Standard was approved by CEN on 14 April 2011.

CEN members are bound to comply with the CEN/CENELEC Internal Regulations which stipulate the conditions for giving this European Standard the status of a national standard without any alteration. Up-to-date lists and bibliographical references concerning such national standards may be obtained on application to the CEN-CENELEC Management Centre or to any CEN member.

This European Standard exists in three official versions (English, French, German). A version in any other language made by translation under the responsibility of a CEN member into its own language and notified to the CEN-CENELEC Management Centre has the same status as the official versions.

CEN members are the national standards bodies of Austria, Belgium, Bulgaria, Croatia, Cyprus, Czech Republic, Denmark, Estonia, Finland, France, Germany, Greece, Hungary, Iceland, Ireland, Italy, Latvia, Lithuania, Luxembourg, Malta, Netherlands, Norway, Poland, Portugal, Romania, Slovakia, Slovenia, Spain, Sweden, Switzerland and United Kingdom.



EUROPEAN COMMITTEE FOR STANDARDIZATION
COMITÉ EUROPÉEN DE NORMALISATION
EUROPÄISCHES KOMITEE FÜR NORMUNG

Management Centre: Avenue Marnix 17, B-1000 Brussels

Annex ZA
(informative)

Relationship between this International Standard and the Essential Requirements of EU Directive 2006/42/EC

This International Standard has been prepared under a mandate given to CEN by the European Commission and the European Free Trade Association to provide a means of conforming to Essential Requirements of the New Approach Directive 2006/42/EC on machinery.

Once this standard is cited in the Official Journal of the European Union under that Directive and has been implemented as a national standard in at least one Member State, compliance with the clauses of this standard confers, within the limits of the scope of this standard, a presumption of conformity with the corresponding Essential Requirements of that Directive excerpt ER 2.2.1.1 and associated EFTA regulations.

WARNING — Other requirements and other EU Directives may be applicable to the product(s) falling within the scope of this standard.

Contents

Page

Foreword	iv
Introduction.....	v
1 Scope	1
2 Normative references	1
3 Terms, definitions and symbols	2
3.1 Terms and definitions	2
3.2 Symbols	3
4 Basic standards and vibration test codes	3
5 Description of the family of machines	3
6 Characterization of vibration	7
6.1 Direction of measurement	7
6.2 Location of measurements	7
6.3 Magnitude of vibration	11
6.4 Combination of vibration directions	12
7 Instrumentation requirements	12
7.1 General	12
7.2 Mounting of transducers	12
7.3 Frequency weighting filter	12
7.4 Integration time	12
7.5 Auxiliary equipment	13
7.6 Calibration	13
8 Testing and operating conditions of the machinery	13
8.1 General	13
8.2 Operating conditions	13
8.3 Other quantities to be specified	14
8.4 Attached equipment, workpiece and task	14
8.5 Operator	19
9 Measurement procedure and validity	19
9.1 Reported vibration values	19
9.2 Declaration and verification of the vibration emission value	19
10 Measurement report	20
Annex A (informative) Model test report for percussive drills, hammers and breakers	21
Annex B (normative) Determination of uncertainty	23
Annex C (normative) Design of steel ball absorber	26
Bibliography	27

Foreword

This document (EN ISO 28927-10:2011) has been prepared by Technical Committee ISO/TC 118 "Compressors and pneumatic tools, machines and equipment" in collaboration with Technical Committee CEN/TC 231 "Mechanical vibration and shock" the secretariat of which is held by DIN.

This European Standard shall be given the status of a national standard, either by publication of an identical text or by endorsement, at the latest by October 2011, and conflicting national standards shall be withdrawn at the latest by October 2011.

Attention is drawn to the possibility that some of the elements of this document may be the subject of patent rights. CEN [and/or CENELEC] shall not be held responsible for identifying any or all such patent rights.

This document supersedes EN 28662-2:1994, EN 28662-3:1994, EN 28662-5:1994.

This document has been prepared under a mandate given to CEN by the European Commission and the European Free Trade Association, and supports essential requirements of EU Directive.

For relationship with EU Directive, see informative Annex ZA, which is an integral part of this document.

According to the CEN/CENELEC Internal Regulations, the national standards organizations of the following countries are bound to implement this European Standard: Austria, Belgium, Bulgaria, Croatia, Cyprus, Czech Republic, Denmark, Estonia, Finland, France, Germany, Greece, Hungary, Iceland, Ireland, Italy, Latvia, Lithuania, Luxembourg, Malta, Netherlands, Norway, Poland, Portugal, Romania, Slovakia, Slovenia, Spain, Sweden, Switzerland and the United Kingdom.

Endorsement notice

The text of ISO 28927-10:2011 has been approved by CEN as a EN ISO 28927-10:2011 without any modification.

Introduction

This document is a type-C standard as stated in ISO 12100.

When requirements of this type-C standard are different from those which are stated in type-A or -B standards, the requirements of this type-C standard take precedence over the requirements of the other standards for machines that have been designed and built according to the requirements of this type-C standard.

The vibration test codes for portable hand-held machines given in ISO 28927 (all parts) are based on ISO 20643, which gives general specifications for the measurement of the vibration emission of hand-held and hand-guided machinery. ISO 28927 (all parts) specifies the operation of the machines under type-test conditions and other requirements for the performance of type tests. The structure/numbering of its clauses follows that of ISO 20643.

The basic principle for transducer positioning first introduced in the IEC 60745 series of European standards is followed, representing a deviation from ISO 20643 for reasons of consistency. The transducers are primarily positioned next to the hand in the area between the thumb and the index finger, where they give the least disturbance to the operator gripping the machine.

It has been found that vibrations generated by percussive machines vary considerably in typical use. For percussive machines, the impacting action is the dominating source of vibration and the variation in the result is affected by the quality of the working/inserted tool, the worked material and the skill of the operator.

The values obtained are type-test values intended to be representative of the average of the upper quartile of typical vibration magnitudes in real-world use of the machines. However, the actual magnitudes vary considerably from time to time and depend on many factors, including the operator, the task and the inserted tool or consumable. The state of maintenance of the machine itself might also be of importance. Under real working conditions the influences of the operator and process can be particularly important at low magnitudes. It is therefore not recommended that emission values below 2,5 m/s² be used for estimating the vibration magnitude under real working conditions. In such cases, 2,5 m/s² is the recommended vibration magnitude for estimating the machine vibration.

If accurate values for a specific work place are required, then measurements [according to ISO 5349 (all parts)] in that work situation could be necessary. Vibration values measured in real working conditions can be either higher or lower than the values obtained using this part of ISO 28927.

Higher vibration magnitudes can easily occur in real work situations, caused by the use of excessively worn or bent inserted tools.

The vibration test codes given in ISO 28927 (all parts) supersede those given in ISO 8662 (all parts) , which has been replaced by the corresponding parts of ISO 28927 (see Foreword).

NOTE ISO 8662-11, *Hand-held portable power tools — Measurement of vibrations at the handle — Part 11: Fastener driving tools*, could be replaced by a future part of ISO 28927.

This page deliberately set blank

Hand-held portable power tools — Test methods for evaluation of vibration emission —

Part 10:

Percussive drills, hammers and breakers

1 Scope

This part of ISO 28927 specifies a laboratory method for measuring hand-transmitted vibration emission at the handles of hand-held power driven percussive machines with and without rotary action [portable rock drills, plug hole drills, rotary hammers, breakers (e.g. pavement breakers, concrete breakers or road breakers), riveting hammers, chipping hammers, pick hammers or similar]. It is a type-test procedure for establishing the magnitude of vibration in the gripping areas of a machine fitted with an inserted tool bit.

This part of ISO 28927 is applicable to hand-held machines (see Clause 5), driven pneumatically or by other means, intended for making holes in hard materials, such as rock and concrete. It is also applicable to breakers intended to work downwards to break hard materials (concrete, rock, pavement, asphalt, etc.) and for hammers intended to work in any direction to perform riveting or chiselling work. It is not applicable to impact drills with direct mechanical impact mechanisms. This part of ISO 28927 is not applicable to jack leg type rock drills and push feed rock drills, which are hand guided (the feed force is not applied by hand, but by an additional device).

It is intended that the results be used to compare different models of the same type of machine.

NOTE To avoid confusion with the terms “power tool” and “inserted tool”, “machine” is used hereinafter for the former.

2 Normative references

The following referenced documents are indispensable for the application of this document. For dated references, only the edition cited applies. For undated references, the latest edition of the referenced document (including any amendments) applies.

ISO 2787, *Rotary and percussive pneumatic tools — Performance tests*

ISO 5349 (all parts), *Mechanical vibration — Measurement and evaluation of human exposure to hand-transmitted vibration*

ISO 5391:2003, *Pneumatic tools and machines — Vocabulary*

ISO 17066, *Hydraulic tools — Vocabulary*

ISO 20643:2005, *Mechanical vibration — Hand-held and hand-guided machinery — Principles for evaluation of vibration emission*

EN 12096, *Mechanical vibration — Declaration and verification of vibration emission values*

3 Terms, definitions and symbols

For the purposes of this document, the terms and definitions given in ISO 5391, ISO 17066 and ISO 20643, and the following apply.

3.1 Terms and definitions

3.1.1

rock drill

percussive power rotating machine with flushing for drilling holes in rock, concrete, etc.

NOTE 1 Adapted from ISO 5391:2003, definition 2.3.1.

NOTE 2 Light rock drills have a mass of ≤ 15 kg (inserted tool excluded when measured). Rock drills >15 kg are defined as heavy rock drills.

3.1.2

rotary hammer

rotary percussive drill with spiral drill bit and without air flushing

[ISO 5391:2003, definition 2.3.2]

3.1.3

breaker

percussive machine for breaking up concrete, rock, brickwork and asphalt, etc.

NOTE 1 Adapted from ISO 5391:2003, definition 2.2.12.

NOTE 2 This type of machine is generally used in a vertical position and is characterized by a "T-handle" with the body of the machine.

3.1.4

plug hole drill

rotating percussive machine with spiral or straight drill mainly intended for drilling in concrete, rock, bricks, etc.

NOTE Adapted from ISO 5391:2003, definition 2.3.3.

3.1.5

chipping hammer

chiselling hammer

percussive machine for chipping, caulking, trimming or fettling castings, welds, etc., normally using chisels or inserted cutting/shaped tools

NOTE Adapted from ISO 5391:2003, definition 2.2.1.

3.1.6

riveting hammer

percussive machine for forming rivet heads

NOTE Adapted from ISO 5391:2003, definition 3.4.1.

3.1.7

pick hammer

percussive machine for light demolition or mine work

NOTE Adapted from ISO 5391:2003, definition 2.2.10.

3.2 Symbols

Symbol	Description	Unit
a_{hw}	root-mean-square (r.m.s.) single-axis acceleration value of the frequency-weighted hand-transmitted vibration	m/s^2
a_{hv}	vibration total value of frequency-weighted r.m.s. acceleration; is the root sum of squares of the a_{hw} values for the three measured axes of vibration	m/s^2
$\overline{a_{hv}}$	arithmetic mean value of a_{hv} values of runs for one operator for one hand position	m/s^2
a_h	arithmetic mean value of $\overline{a_{hv}}$ values for all operators for one hand position	m/s^2
$\overline{a_h}$	arithmetic mean value of a_h values for one hand position on several machines	m/s^2
a_{hd}	declared vibration emission value	m/s^2
s_{n-1}	standard deviation for a test series (for a sample, s)	m/s^2
σ_R	standard deviation of reproducibility (for a population, σ)	m/s^2
C_v	coefficient of variation for a test series	—
K	uncertainty	m/s^2

4 Basic standards and vibration test codes

This part of ISO 28927 is based on the requirements of ISO 20643 and corresponds to its structure in respect of clause subjects and numbering, except for the annexes.

Annex A presents a model test report, Annex B the means for determining the uncertainty, K , and Annex C presents the design of a steel ball absorber.

5 Description of the family of machines

This part of ISO 28927 applies to hand-held machines for rotary percussive tools intended for making holes in hard materials, such as rock and concrete. It also applies to breakers intended to work downwards to break hard materials (concrete, rock, pavement, asphalt, etc.) and to hammers intended to work in any direction to perform riveting or chiselling work.

Typical examples of breakers, hammers and drills covered by this part of ISO 28927 are shown in Figures 1 to 7.



Figure 1 — Breaker/rock drill

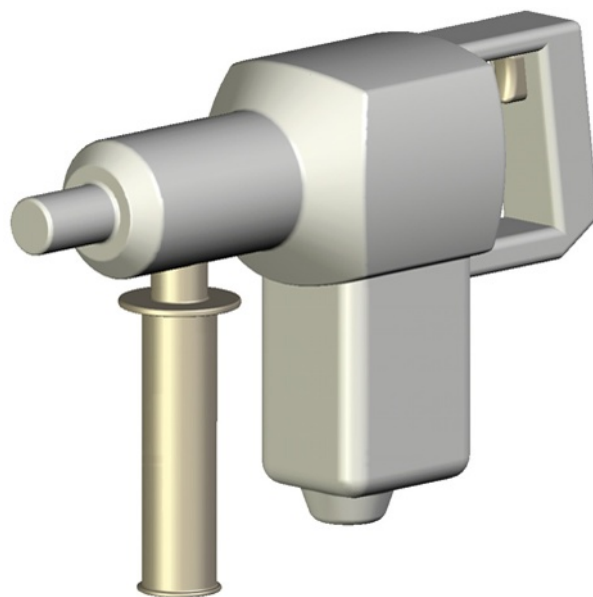

Figure 2 — Rotary hammer



Figure 3 — Large chipping hammer/plug hole drill

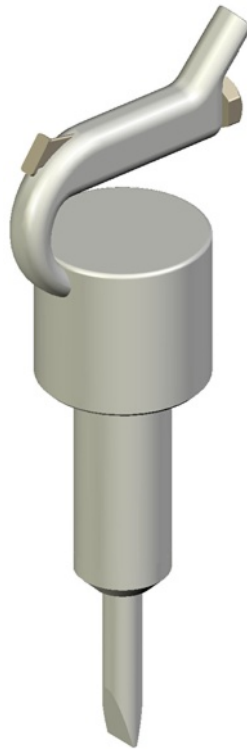

Figure 4 — Small chipping hammer



Figure 5 — Pick hammer

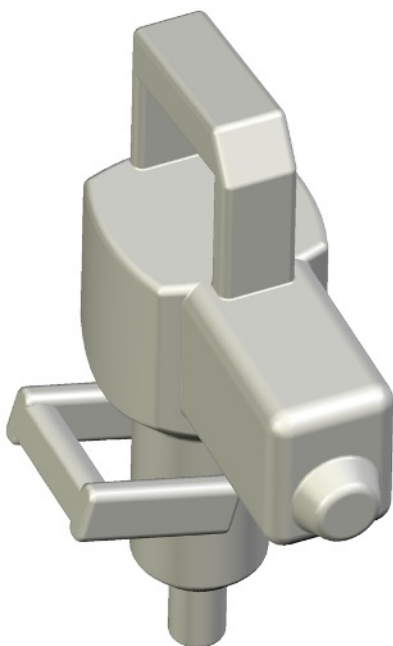
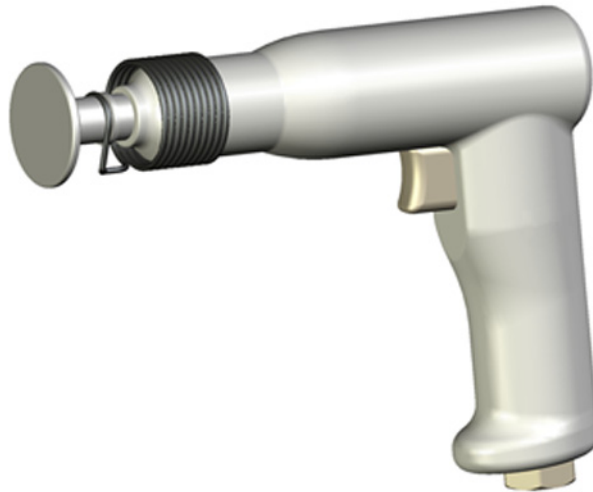

Figure 6 — Chiselling hammer



NOTE This example shows pistol grip.

Figure 7 — Riveting hammer

6 Characterization of vibration

6.1 Direction of measurement

The vibration transmitted to the hand shall be measured and reported for three directions of an orthogonal coordinate system. At each hand position, the vibration shall be measured simultaneously in the three directions shown in Figures 8 to 14.

6.2 Location of measurements

Measurement shall be made at the gripping zones, where the operator normally holds the machine and applies the feed force. For machines intended for one-handed operation, it is only necessary to measure at a single point.

The prescribed transducer location shall be as close as possible to the hand between the thumb and index finger. This shall apply to both hand positions, with the machine held as in normal operation. Whenever possible, measurements shall be made at the prescribed locations.

A secondary location is defined as being on the side of, and as close as possible to, the inner end of the handle where the prescribed location is found. If the prescribed location of the transducer cannot be used, this secondary location shall be used instead.

For breakers and rock drills with anti-vibration T-shaped handles of pivoting design, the transducer shall be positioned in the middle of the handle. Due to the pivoting action, vibration values vary a lot along the length of the handle and the centre of the handle is therefore regarded as being the most representative measurement point. These machines are only guided with low gripping forces and, therefore, the interference between accelerometer and hand is not regarded to be a problem.

Figures 8 to 15 show the prescribed and secondary locations and measurement directions for the hand positions normally used for the different types of machines in this family.

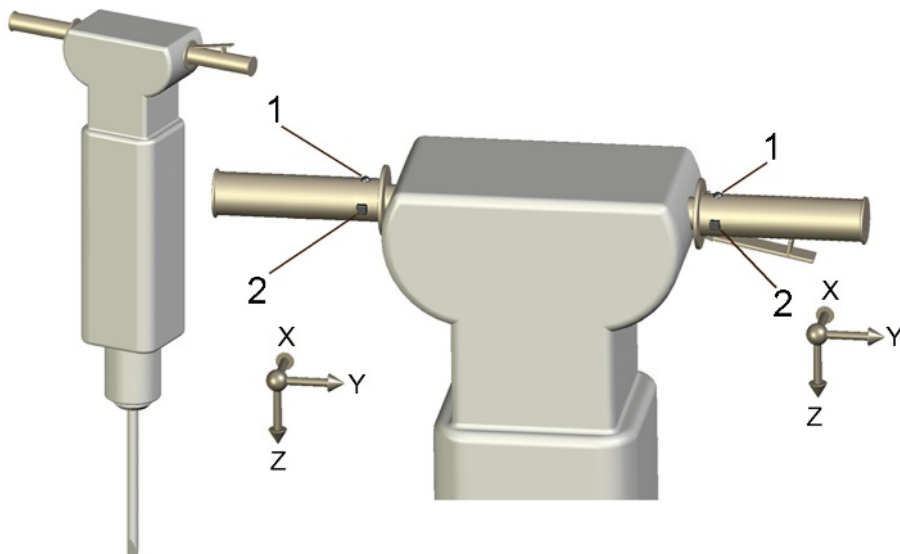

Key
1 prescribed location
2 secondary location

Figure 8 — Breaker/rock drill

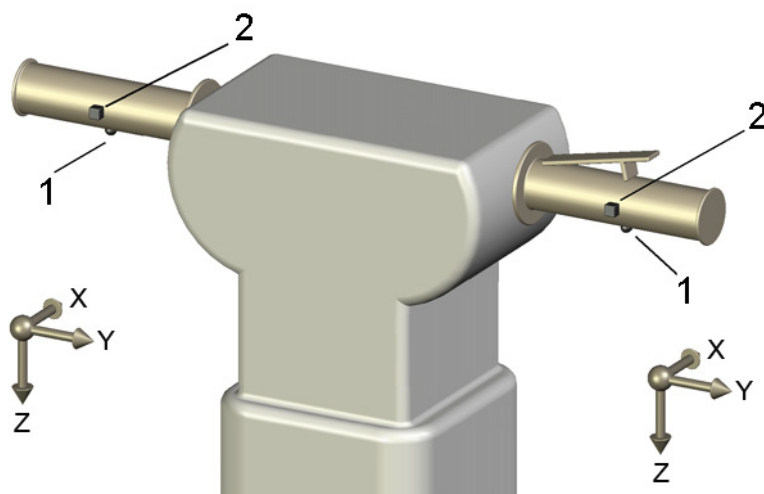

Key
1 prescribed location
2 secondary location

Figure 9 — Optional measurement positions for breaker/rock drill with T-shaped antivibration handles of pivoting type

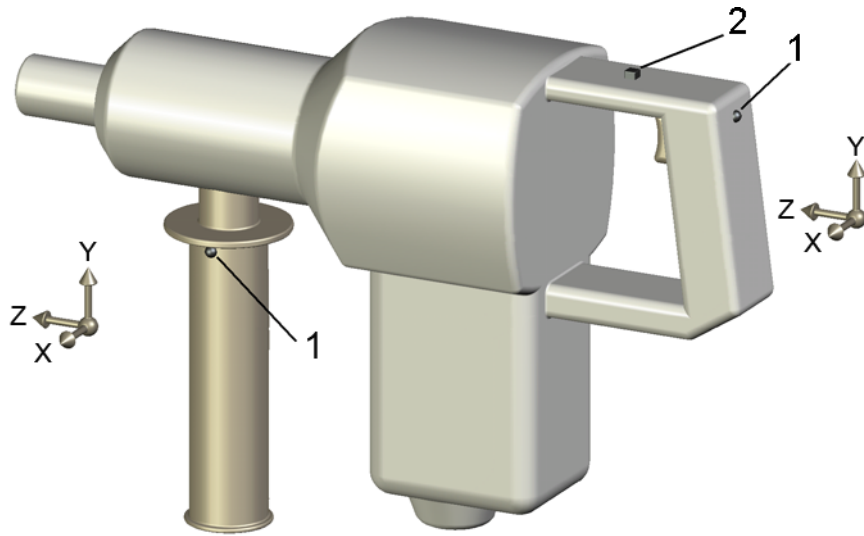

Key

- 1 prescribed location
- 2 secondary location

Figure 10 — Rotary hammer

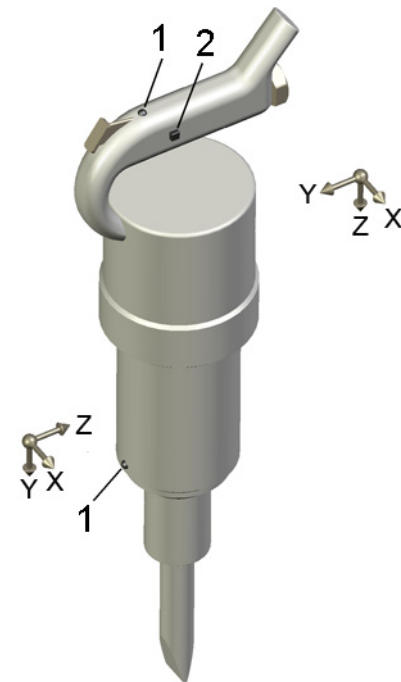

Key

- 1 prescribed location
- 2 secondary location

Figure 11 — Large chipping hammer/plug hole drill

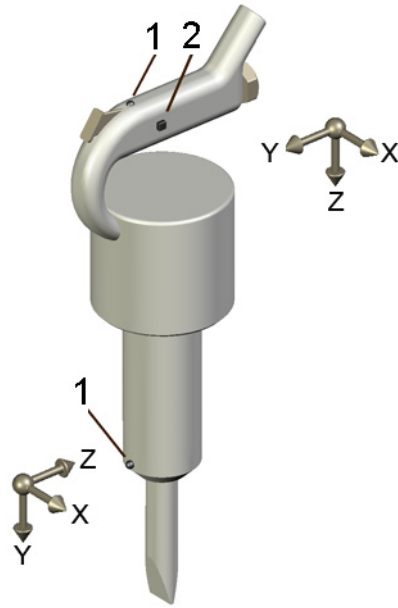
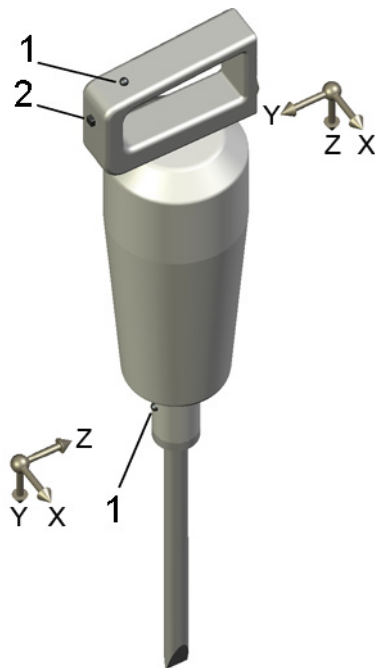

Figure 12 — Small chipping hammer



Key

- 1 prescribed location
- 2 secondary location

Figure 13 — Pick hammer

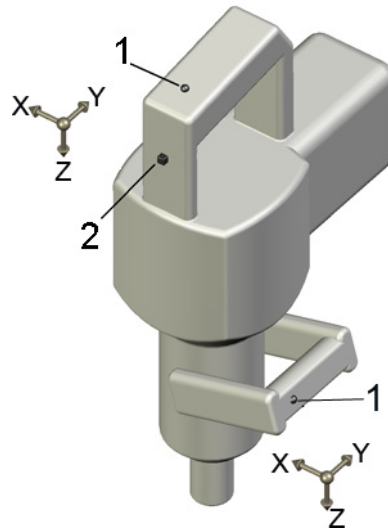

Key

- 1 prescribed location
- 2 secondary location

Figure 14 — Chiselling hammer

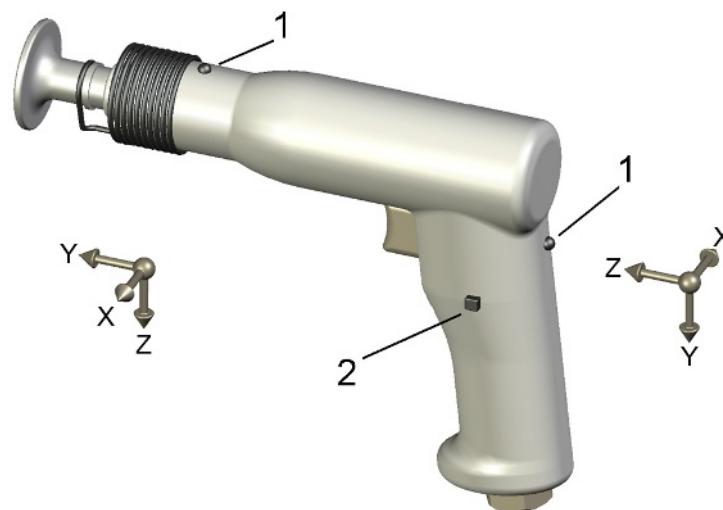

Key

- 1 prescribed location
- 2 secondary location

NOTE This example shows pistol grip.

Figure 15 — Riveting hammer

6.3 Magnitude of vibration

The definitions for the magnitude of vibration given in ISO 20643:2005, 6.3, apply.

6.4 Combination of vibration directions

The vibration total value defined in ISO 20643:2005, 6.4, shall be reported for both hand positions whenever applicable. It is acceptable to report and carry out tests on the hand position having the highest reading. The vibration total value at that hand position shall be at least 30 % higher than the other. This result may be obtained during a preliminary test done by a single operator during five test runs.

To obtain the vibration total value, a_{hv} , for each test run, the results measured in the three directions (x, y and z) shall be combined using Equation (1):

$$a_{hv} = \sqrt{a_{hwx}^2 + a_{hwy}^2 + a_{hwz}^2} \quad (1)$$

7 Instrumentation requirements

7.1 General

The instrumentation shall be in accordance with ISO 20643:2005, 7.1.

7.2 Mounting of transducers

7.2.1 Specification of transducer

The specification for the transducers given in ISO 20643:2005, 7.2.1, applies.

The total mass of the transducers and mounting device shall be small enough, compared with that of the machine, handle, etc., so as not to influence the measurement result.

This is particularly important for low-mass plastic handles (covered in ISO 5349-2).

7.2.2 Fastening of transducers

The transducer or the mounting block used shall be rigidly attached to the surface of the handle.

If three single-axis transducers are used, these shall be attached to three sides of a suitable mounting block.

For the two axes aligned parallel to the vibrating surface, the measurement axes of the two transducers (or the two transducer elements in a triaxial transducer) shall be at a maximum of 10 mm from the surface.

NOTE It is normally necessary to use mechanical filters for measurements according to this part of ISO 28927 to prevent d.c. shifts. At the time of publication of this part of ISO 28927, it is still good practice to use three accelerometers, one for each direction, mounted on a block, each with its own mechanical filter. However, some triaxial accelerometers can be suitable. It is also good practice to be observant of low-frequency components in the measurement signal below the low frequency. Such components are often early signs of d.c. shifts or instrument overload in the high-frequency region.

7.3 Frequency weighting filter

Frequency weighting filters shall be in accordance with ISO 5349-1.

7.4 Integration time

The specifications for the integration time shall be in accordance with ISO 20643:2005, 7.4. The integration time for each test run shall be at least 8 s, so as to be consistent with the duration of machine operation defined in 8.4.4.

7.5 Auxiliary equipment

For pneumatic machines, the air pressure shall be measured using a pressure gauge with an accuracy equal to or better than 0,1 bar¹⁾.

For hydraulic machines, the flow shall be measured using a flow meter with an accuracy equal to or better than 0,25 l/min.

For electrical machines, the voltage shall be measured using a volt meter with an accuracy equal to or better than 3 % of the actual value.

7.6 Calibration

The specifications for calibration given in ISO 20643:2005, 7.6, apply.

8 Testing and operating conditions of the machinery

8.1 General

Measurements shall be carried out on new, and properly serviced and lubricated machines. If for some types of machines, a warming up period is specified by the manufacturer, this shall be used prior to the start of the test.

Machines intended for one-handed operation shall be held with only one hand during the test. Measurements shall be made in one location only and for the hand position used. During measurement, a support handle shall not be mounted.

If a percussive machine can be used with rotation and without rotation, it shall be tested as a rotary drill and a chiselling hammer.

If the percussion of a rotary drill can be switched off, it shall be tested as a rotary hammer and a drill.

During testing, the energy absorber or the workpiece shall be positioned such that the operator can have an upright posture and work the machine vertically downwards while performing the test (see Figures 16 to 18).

The blow frequency of the machine during the test shall be measured and reported. It can be determined by an electronic filter or other suitable means (e.g. using the signal from the vibration transducer).

8.2 Operating conditions

8.2.1 Pneumatic percussive drills, hammers and breakers

During testing, the machine shall be operated at the rated air pressure, and shall be used in accordance with the manufacturer's specifications. The operation shall be stable and smooth. The air pressure shall be measured and reported.

Air shall be supplied to the pneumatic machines by means of a hose with the diameter recommended by the machine manufacturer. The test hose shall be attached to the machine via the threaded hose connector, preferably the one supplied with the machine. The length of the test hose shall be 3 m. The test hose shall be secured with a hose clamp on riveting hammers and chipping hammers. Quick-couplings shall not be used, since their mass influences the vibration magnitude.

1) 1 bar = 0,1 MPa = 0,1 N/mm² = 10⁵ N/m².

The air pressure of pneumatically powered machines shall be measured in accordance with ISO 2787 and be maintained as specified by the manufacturer. During testing, the air pressure measured immediately before the test hose shall not drop more than 0,2 bar below the pressure recommended by the manufacturer.

8.2.2 Non-pneumatic machines

For electrical and hydraulic machines and for machines powered by an internal combustion engine, a warming-up time of about 10 min should be allowed before starting the measurements. During testing, the machine shall operate at the rated power supply, i.e. the rated voltage or flow, and shall be used in accordance with the manufacturer's specifications. The operation of the machine shall be stable and smooth. The voltage or flow shall be measured and reported.

If a run-in time of a new machine is necessary to obtain the declared performance of the machine as defined by the manufacturer, the machine shall be run in according to these specifications before the test.

8.3 Other quantities to be specified

Feed force shall be measured and reported. The blow frequency shall be measured and reported.

8.4 Attached equipment, workpiece and task

8.4.1 Rotary hammers, plug hole drills and light rock drills

These machines are tested by drilling holes vertically downwards into non-reinforced concrete as shown in Figure 16. The concrete shall have an aggregate contribution as specified in Table 1. The compressive strength of the block shall be determined in accordance with ISO 679.

The dimensions of the block shall be at least 800 mm × 500 mm × 200 mm.

Table 1 — Concrete formulation (per cubic metre)

Cement ^a kg	Water m ³	Aggregate ^b 1 844 kg	
		Particle size mm	Fraction %
330	0,183	0 to 2	38 ± 3
		0 to 8	50 ± 5
		0 to 16	80 ± 5
		0 to 32	100
Compressive strength after 28 days shall be 40 N/mm ² .			
NOTE The particle size between 16 mm to 32 mm can be hard to find. In that case, a lower fraction of that size can be accepted.			
^a The water:cement mass ratio shall be 0,55 ± 0,02 (the mass tolerance of cement and water is +10 % to enable the concrete manufacturer to ensure compressive strength with local cement).			
^b Very hard aggregates, such as flint or granite, and very soft aggregates, such as limestone, shall not be used.			

For the test, the concrete block shall lie flat on a damping material (e.g. sand, insulation matting or wooden planks) to compensate for any unevenness of the surface. The concrete block shall not have any resonances within the frequency range for the hand-arm vibration as this can influence the test results.

8.4.2 Heavy rock drills and breakers without rotation

For heavy rock drills and breakers without rotation, a steel ball energy absorbing device shall be used as the loading device.

For heavy rock drills the drill bit shall rotate during the test.

These machines shall be operated vertically downwards on the loading device as shown in Figure 17. The machine piece (shank) shall not come into contact with the bushing as this can influence the test result.

The energy absorber shall be chosen from Table 2 according to the shank diameter or flat dimension (key size) d , of the inserted tool.

The energy absorber shall be mounted on a concrete block or base plate having a mass of at least 300 kg. The mounted energy absorber shall not have any resonances within the frequency range for the hand-arm vibration that could influence the test results.

8.4.3 Chiselling, chipping and riveting hammers

For chiselling, chipping and riveting hammers a steel ball energy absorbing device shall be used as the loading device.

These machines shall be operated vertically downwards on the loading device as shown in Figure 18. The chisel shall not come into contact with the bushing as this can influence the test result.

The energy absorber shall be chosen from Table 2 according to the shank diameter or flat dimension.

The energy absorber shall be mounted on a concrete block or base plate having a mass of at least 300 kg. The mounted energy absorber shall not have any resonances within the frequency range for the hand-arm vibration that could influence the test results.

Table 2 — Choice of size for the energy absorber

Shank dimension d mm	Energy absorber size	Steel tube diameter D mm	Steel ball diameter mm	Ball column height H mm
$d < 23$	40	40	4	100
$d \geq 23$	60	60	4	150

Further information about the loading device can be found in Annex C.



NOTE The operator is standing on a scale.

Figure 16 — Working position of operator — Light rock drill, plug hole drill and rotary hammer — Example

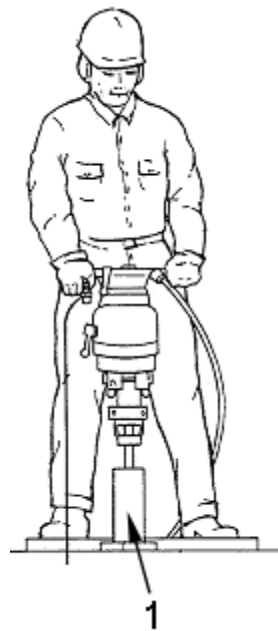

Key

1 steel ball energy absorber

NOTE The operator is standing on a scale.

Figure 17 — Working position of operator — Rock drill and breaker — Example



NOTE The operator is standing on a scale.

Figure 18 — Working position of operator — Chiselling hammer, chipping hammer, riveting hammer and pick hammer — Example

8.4.4 Feed force

The feed force to be applied, in addition to the weight of the machine, shall ensure that it operates at its normal level of performance, such that there is stable operation and no contact is established between the collar of the inserted tool and the machine chuck.

Excessive feed force shall be avoided. Vibration-reducing mechanisms shall not be overloaded to allow them proper operation.

NOTE For electrical machines, in general, stable operation with good performance is achieved by increasing the feed force by 30 N after the hammer has stopped bouncing and is operating smoothly.

The feed force shall be monitored and controlled during the test by letting the operator stand on a scale. The feed force is then the operator's own mass minus the reading on the scale.

8.4.5 Test procedure

8.4.5.1 General

Three operators shall each carry out a series of five measurements in accordance with this subclause (8.4.5.1) to 8.4.5.4.

A complete test sequence is set out in the model test report given in Annex A.

During the test, the workpiece or the energy absorber shall be positioned such that the operator can have an upright posture and work the machine vertically downward while performing the test (see Figures 16 to 18).

Each test run shall be such that the measurements can be carried out for not less than 8 s (drilling into concrete or working on the loading device), unless it is not possible, e.g. for a small drill bit with a very powerful machine.

8.4.5.2 Test procedure for rotary hammers, plug hole drills and light rock drills

Readings should be started once the drill bit comes into contact with the concrete block and stopped when the bit has reached a depth which is 80 % of the drill rod working length or before the bit breaks through the lower surface of the block.

The drill bit chosen for the test of non-electrical machines shall be according to Table 3. Start the test with a new drill bit.

Table 3 — Drill bit dimensions for non-electrical machines, as a function of the weight class

Machine weight kg	Approximate drill bit diameter mm	Approximate working length mm
≤8	15	200
>8	30	400

The working length and drill bit diameter should be chosen from the range of standard lengths and drill bit diameters, but should be as close as possible to the appropriate value recommended in this table.

For electrical machines, the diameter shall be selected according to its weight according to Table 4. Start the test with a new drill bit.

Table 4 — Drill bit dimension for electrical machines, as a function of weight class

Tool mass kg	≤3,5	>3,5 ≤5	>5 ≤7	>7 ≤10	>10 ≤18	>18
Diameter of drill bit mm	10	16	20	25	32	40
Usable length of drill bit mm	100		200		250	

8.4.5.3 Test procedure for heavy rock drills and breakers

Each measurement starts after stable operation is established, while operating the machine with normal feed force on the energy absorber, and stops after the minimum of 8 s of operation time.

For heavy rock drills the tool piece shall rotate during the test.

8.4.5.4 Test procedure for chiselling, chipping and riveting hammers

Each measurement starts after stable operation is established, while operating the machine with normal feed force on the energy absorber, and stops after the minimum of 8 s of operation time.

Machines intended to be operated horizontally with two hands shall be operated vertically on the energy absorber with one hand on the trigger position and one hand on the rear end of the machine. Measurements shall still be carried out on the front part of the machine as indicated in Figures 16 to 18. If the hammer is intended for use with a conventional chisel or bush (without a sleeve) and this is in contact with the operator's hand in intended use, it is not usually practicable to measure the vibration on the chisel or bush. However, it is likely that the vibration at this hand position would be much greater than that measured on the hammer. In such cases, a vibration emission value of "greater than 30 m/s²" shall be declared and measurement is not required.

8.5 Operator

Three different operators shall operate the machine during testing. The vibration of the machine can be influenced by the operators. They shall, therefore, be skilled enough to be able to hold and operate the machine correctly.

9 Measurement procedure and validity

9.1 Reported vibration values

Three series of five consecutive tests shall be carried out on each machine being tested, using a different operator for each series.

The values (see 6.4) should be reported for each machine as in Annex A.

The coefficient of variation, C_v , and the standard deviation, s_{n-1} , shall be calculated for each hand position for each of the three operators. The C_v of a test series is defined as the ratio of s_{n-1} to the mean value of the series:

$$C_v = \frac{s_{n-1}}{a_{hv}} \quad (2)$$

where the standard deviation of the i th value, a_{hvi} , measured and corrected using Equation (2) and expressed in m/s^2 , is

$$s_{n-1} = \sqrt{\frac{1}{n-1} \sum_{i=1}^n (a_{hvi} - \overline{a_{hv}})^2} \quad (3)$$

where

$\overline{a_{hv}}$ is the mean value of the series in m/s^2 ;

n is equal to five, the number of measured values.

If C_v is greater than 0,15, or s_{n-1} is greater than 0,3 m/s^2 , then the measurements shall be checked for error before the data are accepted.

9.2 Declaration and verification of the vibration emission value

The $\overline{a_{hv}}$ value for each operator shall be calculated as the arithmetic mean of the a_{hv} values for the five test runs.

For each hand position, the result from the three operators should be combined to one value, a_h , using the arithmetic mean of the three $\overline{a_{hv}}$ values.

For tests using only one machine, the declared value, a_{hd} , is the highest of the a_h values reported for the two hand positions.

For tests using three or more machines, $\overline{a_h}$ values for each hand position shall be calculated as the arithmetic mean of the a_h values for the different machines on that hand position. The declared value, a_{hd} , is the highest of the a_h values reported for the two hand positions.

Both a_{hd} and the uncertainty, K , shall be presented with the precision determined in EN 12096. The value of a_{hd} is to be given in m/s^2 and presented by using two and a half significant digits for numbers starting with 1

(e.g. 1,20 m/s², 14,5 m/s²); otherwise two significant digits are sufficient (e.g. 0,93 m/s², 8,9 m/s²). The value of K shall be presented with the same number of decimals as a_{hd} .

K shall be determined in accordance with EN 12096, based on the standard deviation of reproducibility, σ_R . The value of K shall be calculated in accordance with Annex B.

10 Measurement report

The following information shall be given in the test report:

- a) reference to this part of ISO 28927, i.e. ISO 28927-10:2011;
- b) name of the measuring laboratory;
- c) date of measurement and name of the persons responsible for the test;
- d) specification of the hand-held machine (manufacturer, type, serial number, etc.);
- e) declared emission value, a_{hd} , and uncertainty, K ;
- f) attached or inserted tools;
- g) energy supply (air pressure/input voltage, etc., as applicable);
- h) instrumentation (accelerometer mass, integrators, recording system hardware, software, etc.);
- i) position and fastening of transducers, measuring directions and individual vibration values;
- j) operating conditions as specified in 8.2 and 8.3;
- k) detailed results of the test (see Annex A).

If transducer positions or measurements other than those specified in this part of ISO 28927 are used, they shall be clearly defined and an explanation of the reason for the change in the position of the transducer shall be inserted in the test report.

Annex A
(informative)

Model test report for percussive drills, hammers and breakers

See Tables A.1 and A.2.

Table A.1 — General information and reported results

The test has been carried out in accordance with ISO 28927-10, <i>Hand-held portable power tools — Test methods for evaluation of vibration emission — Part 10: Percussive drills, hammers and breakers</i>	
Tester:	
Measured by (company/institution):	Tested by: Reported by: Date:
Test object and declared value:	
Machine tested (power supply and machine type, manufacturer, machine model and name, weight):	Declared vibration emission value, a_{hd} , and uncertainty, K :
Measuring equipment:	
Transducers (manufacturer, type, positioning, fastening method, photos, mechanical filters, if used):	
Vibration instrumentation:	Auxiliary equipment:
Operating and test conditions and results:	
Test conditions (see 8.2 to 8.4; test method used, size of energy absorber, operator posture and hand positions):	
Power supply (air pressure, hydraulic flow, voltage):	Measured feed force:
Measured blow frequency:	Any other quantities to report:

Table A.2 — Measurement results for one machine

Date:		Machine type:				Serial number:				Measured blow frequency:			
Test	Operator	Test run	Main handle (hand position 1)				Support handle (hand position 2)						
			a_{hwz}	a_{hwy}	a_{hwz}	a_{hvw}	a_{hwz}	a_{hwy}	a_{hwz}	a_{hvw}			
			Statistics for operator		Statistics for operator		Statistics for operator		Statistics for operator				
			$\overline{a_{hv}}$	C_v	$\overline{a_{hv}}$	C_v	$\overline{a_{hv}}$	C_v	$\overline{a_{hv}}$	C_v			
1	1	1											
2	1	2											
3	1	3											
4	1	4											
5	1	5											
6	2	1											
7	2	2											
8	2	3											
9	2	4											
10	2	5											
11	3	1											
12	3	2											
13	3	3											
14	3	4											
15	3	5											
			a_h for hand position 1:		a_h for hand position 2:		a_h for hand position 2:		a_h for hand position 2:				
			s_R for hand position 1:		s_R for hand position 1:		s_R for hand position 2:		s_R for hand position 2:				

NOTE The a_{hv} and $\overline{a_{hv}}$ values are calculated according to 6.4 and 9.2, s_{p-1} and C_v are calculated according to 9.1, and s_R is calculated according to Annex B.

Annex B (normative)

Determination of uncertainty

B.1 General

The uncertainty value, K , represents the uncertainty of the declared vibration emission value, a_{hd} , and, in the case of batches, production variations of machinery. It is expressed in metres per square second (m/s^2).

The sum of a_{hd} and K indicates the limit below which the vibration emission value of a single machine, and/or a specified large proportion of the vibration emission values of a batch of machines, are stated to lie when the machines are new.

B.2 Tests on single machines

For tests made on only a single machine, K shall be given as

$$K = 1,65 \sigma_R$$

where σ_R is the standard deviation of reproducibility, estimated by the value, s_R , given by

$$a) \quad s_R = \sqrt{s_{rec}^2 + s_{op}^2}$$

or

$$b) \quad s_R = 0,06a_{hd} + 0,3$$

whichever is the greater.

NOTE 1 Equation b) is empirical, based on experience giving a lower limit for s_R .

The calculations are performed on the hand position giving the highest value of a_h , where

$\overline{s_{rec}^2}$ is the arithmetic mean value of the standard deviation from the results of five tests, s_{recj} , for operator j , identical to s_{n-1} according to 9.2, and with the s_{recj}^2 value for each operator calculated using

$$s_{recj}^2 = \frac{1}{n-1} \sum_{i=1}^n (a_{hvj} - \overline{a_{hv}j})^2$$

where

n is equal to 5, the number of measured values;

a_{hvj} is the vibration total value for the i th test with the j th operator;

$\overline{a_{hv}j}$ is the average vibration total value of measurements on the j th operator;

s_{op} is the standard deviation of the results from the three operators, i.e.

$$s_{op}^2 = \frac{1}{m-1} \sum_{j=1}^m (\overline{a_{hvj}} - a_h)^2$$

where

m is equal to 3, i.e. the number of operators;

$\overline{a_{hvj}}$ is the average vibration value from the j th operator (average of five tests);

a_h is the average vibration value from all three operators;

a_{hd} is the highest of the a_h values reported for the two hand positions.

NOTE 2 The value of s_R is an estimate of the standard deviation of reproducibility of testing performed at different test centres. Since, at the time of publication, there is currently no information on reproducibility for the tests defined in this part of ISO 28927, the value for s_R is based on the repeatability of the test for individual test subjects and across the different test subjects, according to EN 12096.

B.3 Tests on batches of machines

For tests on three or more machines, the K value shall be given as

$$K = 1,5\sigma_t$$

where σ_t is estimated by the value s_t , given by

$$a) \quad s_t = \sqrt{s_R^2 + s_b^2}$$

or

$$b) \quad s_t = 0,06a_{hd} + 0,3$$

whichever is the greater.

The calculations are performed on the hand position giving the highest value of $\overline{a_h}$ and where

$\overline{s_R^2}$ is the mean value of s_R^2 for the different machines in the batch, with the s_R value for each machine calculated using B.2 a), above;

s_b is the standard deviation of the test results for individual machines, i.e.

$$s_b^2 = \frac{1}{p-1} \sum_{l=1}^p (a_{hl} - \overline{a_h})^2$$

where

a_{hl} is the single-machine emission for one hand position on the l th machine;

- \bar{a}_h is the mean value of the single-machine emissions for one hand position;
- a_{hd} is the highest of the \bar{a}_h values reported for the two hand positions;
- p is the number of machines tested (≥ 3).

Annex C (normative)

Design of steel ball absorber

C.1 General

A detailed description of the energy absorber and the inserted tool that shall be used is found in Reference [5].

The energy absorber consists of a steel tube, which is firmly mounted on a rigid base plate, having a minimum mass of 300 kg to prevent the machine from jumping, and filled with balls of hardened steel. At the top of the steel tube, resting on the balls, is inserted a test tool on which the machine works.

C.2 Energy absorber

Figure C.1 illustrates an energy absorber (loading device) and a test tool used to test electrical machines. The illustration shows changes (regarding dimensions) made to Reference [5] (the DYNALOAD document).

NOTE The dynamic loading device is given the common name of DYNALOAD.

Dimensions in millimetres

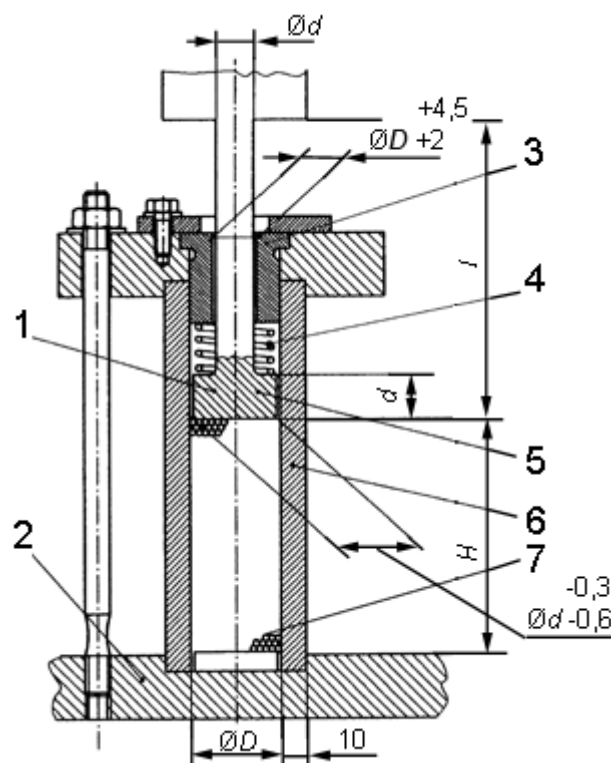

Key

- | | |
|---|--|
| 1 optional design of the inserted (test) tool | 5 hardened steel 55 HRC \pm 2 HRC |
| 2 steel plate mounted on a concrete block | 6 hardened steel 62 HRC \pm 2 HRC |
| 3 bushing | 7 hardened steel min. 63 HRC |
| 4 spring, rate <math>< 1,2</math> N/mm, slightly pre-stressed | l length of the inserted (test) tool |

Figure C.1 — Steel ball energy absorber for electrical tools

Electrical machines shall be tested on a modified energy absorber in accordance with Figure C.1. The illustration shows changes (regarding dimensions) made relative to the DYNALOAD document.

Bibliography

- [1] ISO 679, *Cement — Test methods — Determination of strength*
- [2] ISO 12100, *Safety of machinery — General principles for design — Risk assessment and risk reduction*
- [3] EN 755-2, *Aluminium and aluminium alloys — Extruded rod/bar, tube and profiles — Part 2: Mechanical properties*
- [4] IEC 60745 (all parts), *Hand-held motor-operated electric tools — Safety*
- [5] *DYNALOAD: Design, construction, use and maintenance*. PNEUROP, version 1.2, October 2005. Available at www.pneurop.eu/uploads/documents/pdf/DYNALOAD_2005.pdf²⁾

2) European Committee of Manufacturers of Compressors, Vacuum Pumps, Pneumatic Tools and Air and Condensate Treatment Equipment, represented by their National Associations (PNEUROP), Secretariat located at the British Compressed Air Society, Leicester House 8 Leicester Street, London WC2H 7BN, United Kingdom.

British Standards Institution (BSI)

BSI is the national body responsible for preparing British Standards and other standards-related publications, information and services.

BSI is incorporated by Royal Charter. British Standards and other standardization products are published by BSI Standards Limited.

About us

We bring together business, industry, government, consumers, innovators and others to shape their combined experience and expertise into standards-based solutions.

The knowledge embodied in our standards has been carefully assembled in a dependable format and refined through our open consultation process. Organizations of all sizes and across all sectors choose standards to help them achieve their goals.

Information on standards

We can provide you with the knowledge that your organization needs to succeed. Find out more about British Standards by visiting our website at bsigroup.com/standards or contacting our Customer Services team or Knowledge Centre.

Buying standards

You can buy and download PDF versions of BSI publications, including British and adopted European and international standards, through our website at bsigroup.com/shop, where hard copies can also be purchased.

If you need international and foreign standards from other Standards Development Organizations, hard copies can be ordered from our Customer Services team.

Subscriptions

Our range of subscription services are designed to make using standards easier for you. For further information on our subscription products go to bsigroup.com/subscriptions.

With **British Standards Online (BSOL)** you'll have instant access to over 55,000 British and adopted European and international standards from your desktop. It's available 24/7 and is refreshed daily so you'll always be up to date.

You can keep in touch with standards developments and receive substantial discounts on the purchase price of standards, both in single copy and subscription format, by becoming a **BSI Subscribing Member**.

PLUS is an updating service exclusive to BSI Subscribing Members. You will automatically receive the latest hard copy of your standards when they're revised or replaced.

To find out more about becoming a BSI Subscribing Member and the benefits of membership, please visit bsigroup.com/shop.

With a **Multi-User Network Licence (MUNL)** you are able to host standards publications on your intranet. Licences can cover as few or as many users as you wish. With updates supplied as soon as they're available, you can be sure your documentation is current. For further information, email bsmusales@bsigroup.com.

BSI Group Headquarters

389 Chiswick High Road London W4 4AL UK

Revisions

Our British Standards and other publications are updated by amendment or revision.

We continually improve the quality of our products and services to benefit your business. If you find an inaccuracy or ambiguity within a British Standard or other BSI publication please inform the Knowledge Centre.

Copyright

All the data, software and documentation set out in all British Standards and other BSI publications are the property of and copyrighted by BSI, or some person or entity that owns copyright in the information used (such as the international standardization bodies) and has formally licensed such information to BSI for commercial publication and use. Except as permitted under the Copyright, Designs and Patents Act 1988 no extract may be reproduced, stored in a retrieval system or transmitted in any form or by any means – electronic, photocopying, recording or otherwise – without prior written permission from BSI. Details and advice can be obtained from the Copyright & Licensing Department.

Useful Contacts:

Customer Services

Tel: +44 845 086 9001

Email (orders): orders@bsigroup.com

Email (enquiries): cservices@bsigroup.com

Subscriptions

Tel: +44 845 086 9001

Email: subscriptions@bsigroup.com

Knowledge Centre

Tel: +44 20 8996 7004

Email: knowledgecentre@bsigroup.com

Copyright & Licensing

Tel: +44 20 8996 7070

Email: copyright@bsigroup.com



...making excellence a habit.™