



BSI Standards Publication

Vitreous and porcelain enamels — Determination of resistance to chemical corrosion

Part 4: Determination of resistance to
chemical corrosion by alkaline liquids using
a cylindrical vessel

National foreword

This British Standard is the UK implementation of EN ISO 28706-4:2016. It supersedes BS EN ISO 28706-4:2011 which is withdrawn.

The UK participation in its preparation was entrusted to Technical Committee STI/36, Vitreous enamel coatings.

A list of organizations represented on this committee can be obtained on request to its secretary.

This publication does not purport to include all the necessary provisions of a contract. Users are responsible for its correct application.

© The British Standards Institution 2016.
Published by BSI Standards Limited 2016

ISBN 978 0 580 86615 9

ICS 25.220.50

Compliance with a British Standard cannot confer immunity from legal obligations.

This British Standard was published under the authority of the Standards Policy and Strategy Committee on 31 January 2016.

Amendments/corrigenda issued since publication

| Date | Text affected |
|------|---------------|
|------|---------------|

EUROPEAN STANDARD

EN ISO 28706-4

NORME EUROPÉENNE

EUROPÄISCHE NORM

January 2016

ICS 25.220.50

Supersedes EN ISO 28706-4:2011

English Version

Vitreous and porcelain enamels - Determination of
resistance to chemical corrosion - Part 4: Determination of
resistance to chemical corrosion by alkaline liquids using a
cylindrical vessel (ISO 28706-4:2016)

Émaux vitrifiés - Détermination de la résistance à la
corrosion chimique - Partie 4: Détermination de la
résistance à la corrosion chimique par des liquides
alcalins dans un récipient cylindrique (ISO 28706-
4:2016)

Emails und Emailierungen - Bestimmung der
Beständigkeit gegen chemische Korrosion - Teil 4:
Bestimmung der Beständigkeit gegen chemische
Korrosion durch alkalische Flüssigkeiten unter
Verwendung eines Gerätes mit zylindrischem Gefäß
(ISO 28706-4:2016)

This European Standard was approved by CEN on 7 November 2015.

CEN members are bound to comply with the CEN/CENELEC Internal Regulations which stipulate the conditions for giving this European Standard the status of a national standard without any alteration. Up-to-date lists and bibliographical references concerning such national standards may be obtained on application to the CEN-CENELEC Management Centre or to any CEN member.

This European Standard exists in three official versions (English, French, German). A version in any other language made by translation under the responsibility of a CEN member into its own language and notified to the CEN-CENELEC Management Centre has the same status as the official versions.

CEN members are the national standards bodies of Austria, Belgium, Bulgaria, Croatia, Cyprus, Czech Republic, Denmark, Estonia, Finland, Former Yugoslav Republic of Macedonia, France, Germany, Greece, Hungary, Iceland, Ireland, Italy, Latvia, Lithuania, Luxembourg, Malta, Netherlands, Norway, Poland, Portugal, Romania, Slovakia, Slovenia, Spain, Sweden, Switzerland, Turkey and United Kingdom.



EUROPEAN COMMITTEE FOR STANDARDIZATION
COMITÉ EUROPÉEN DE NORMALISATION
EUROPÄISCHES KOMITEE FÜR NORMUNG

CEN-CENELEC Management Centre: Avenue Marnix 17, B-1000 Brussels

European foreword

This document (EN ISO 28706-4:2016) has been prepared by Technical Committee ISO/TC 107 “Metallic and other inorganic coatings” in collaboration with Technical Committee CEN/TC 262 “Metallic and other inorganic coatings” the secretariat of which is held by BSI.

This European Standard shall be given the status of a national standard, either by publication of an identical text or by endorsement, at the latest by July 2016, and conflicting national standards shall be withdrawn at the latest by July 2016.

Attention is drawn to the possibility that some of the elements of this document may be the subject of patent rights. CEN [and/or CENELEC] shall not be held responsible for identifying any or all such patent rights.

This document supersedes EN ISO 28706-4:2011.

According to the CEN-CENELEC Internal Regulations, the national standards organizations of the following countries are bound to implement this European Standard: Austria, Belgium, Bulgaria, Croatia, Cyprus, Czech Republic, Denmark, Estonia, Finland, Former Yugoslav Republic of Macedonia, France, Germany, Greece, Hungary, Iceland, Ireland, Italy, Latvia, Lithuania, Luxembourg, Malta, Netherlands, Norway, Poland, Portugal, Romania, Slovakia, Slovenia, Spain, Sweden, Switzerland, Turkey and the United Kingdom.

Endorsement notice

The text of ISO 28706-4:2016 has been approved by CEN as EN ISO 28706-4:2016 without any modification.

Contents

Page

| | |
|--|-----------|
| Foreword | iv |
| Introduction | v |
| 1 Scope | 1 |
| 2 Normative references | 1 |
| 3 Principle | 1 |
| 4 Reagents | 2 |
| 5 Apparatus and material | 2 |
| 6 Test specimens | 7 |
| 7 Procedure | 7 |
| 8 Expression of results | 8 |
| 8.1 Total loss in mass per unit area..... | 8 |
| 8.2 Corrosion rate..... | 8 |
| 9 Hot 0,1 mol/l sodium hydroxide test | 9 |
| 9.1 General..... | 9 |
| 9.2 Test solution, $c(\text{NaOH}) = 0,1 \text{ mol/l}$ | 9 |
| 9.3 Test temperature..... | 9 |
| 9.4 Duration of the test..... | 9 |
| 9.5 Test report..... | 9 |
| 10 Hot 1,0 mol/l sodium hydroxide test | 10 |
| 10.1 General..... | 10 |
| 10.2 Test solution, $c(\text{NaOH}) = 1,0 \text{ mol/l}$ | 10 |
| 10.3 Test temperature..... | 10 |
| 10.4 Duration of the test..... | 10 |
| 10.5 Test report..... | 10 |
| 11 Other test solutions | 11 |
| 11.1 General..... | 11 |
| 11.2 Test solution..... | 11 |
| 11.3 Test temperature..... | 11 |
| 11.4 Duration of the test..... | 11 |
| 11.5 Test report..... | 11 |
| Bibliography | 12 |

Foreword

ISO (the International Organization for Standardization) is a worldwide federation of national standards bodies (ISO member bodies). The work of preparing International Standards is normally carried out through ISO technical committees. Each member body interested in a subject for which a technical committee has been established has the right to be represented on that committee. International organizations, governmental and non-governmental, in liaison with ISO, also take part in the work. ISO collaborates closely with the International Electrotechnical Commission (IEC) on all matters of electrotechnical standardization.

The procedures used to develop this document and those intended for its further maintenance are described in the ISO/IEC Directives, Part 1. In particular the different approval criteria needed for the different types of ISO documents should be noted. This document was drafted in accordance with the editorial rules of the ISO/IEC Directives, Part 2 (see www.iso.org/directives).

Attention is drawn to the possibility that some of the elements of this document may be the subject of patent rights. ISO shall not be held responsible for identifying any or all such patent rights. Details of any patent rights identified during the development of the document will be in the Introduction and/or on the ISO list of patent declarations received (see www.iso.org/patents).

Any trade name used in this document is information given for the convenience of users and does not constitute an endorsement.

For an explanation on the meaning of ISO specific terms and expressions related to conformity assessment, as well as information about ISO's adherence to the WTO principles in the Technical Barriers to Trade (TBT) see the following URL: [Foreword - Supplementary information](#).

The committee responsible for this document is ISO/TC 107, *Metallic and other inorganic coatings*.

This third edition cancels and replaces the second edition (ISO 28706-4:2008), of which it constitutes a minor revision.

ISO 28706 consists of the following parts, under the general title *Vitreous and porcelain enamels — Determination of resistance to chemical corrosion*:

- *Part 1: Determination of resistance to chemical corrosion by acids at room temperature*
- *Part 2: Determination of resistance to chemical corrosion by boiling acids, boiling neutral liquids and/or their vapours*
- *Part 3: Determination of resistance to chemical corrosion by alkaline liquids using a hexagonal vessel*
- *Part 4: Determination of resistance to chemical corrosion by alkaline liquids using a cylindrical vessel*
- *Part 5: Determination of resistance to chemical corrosion in closed systems*

Introduction

Corrosion of vitreous and porcelain enamels by aqueous solutions is a dissolution process. The main component of the enamel, SiO_2 , forms a three-dimensional silica network. After hydrolysis, it decomposes and forms silicic acid or silicates. These are released into the attacking medium. Other components, mainly metal oxides, are hydrolysed as well and form the corresponding hydrated metal ions or hydroxides. All corrosion products are more or less soluble in the attacking medium. The whole process results in a loss in mass per unit area.

For some aqueous solutions, the attack on the enamel proceeds linearly during the corrosion time; for other aqueous solutions, the attack on the enamel proceeds in a logarithmic manner during the corrosion time. Only for the first series of solutions can a scientifically exact rate of loss in mass per unit area ($\text{g}/\text{m}^2\cdot\text{h}$) be calculated as well as a corrosion rate (mm/year).

The most important parameters influencing aqueous corrosion of the enamel are the enamel quality, the temperature and the pH-value. Inhibition effects resulting from the limited solubility of silica can also contribute. The following list describes different types of enamel attack for different corrosion conditions:

- a) In aqueous alkali solutions like 0,1 mol/l NaOH (see [Clause 9](#) of this part of ISO 28706), the silica network of the enamel is considerably attacked at 80 °C. Silicates and most of the other hydrolysed components are soluble in the alkali. Attack proceeds linearly during regular test times. Therefore, test results are expressed in terms of a rate of loss in mass per unit area (mass loss per unit area and time) and a corrosion rate (millimetres per year).
- b) At room temperature, in weak aqueous acids like citric acid (see ISO 28706-1:2008, Clause 9) or also in stronger acids like sulfuric acid (see ISO 28706-1:2008, Clause 10), there is only minor attack on the silica network of the enamel. Other constituents are leached to some extent from the surface. Highly resistant enamels will show no visual change after exposure. On less resistant enamels, some staining or surface roughening will occur.
- c) In boiling aqueous acids (see ISO 28706-2), the silica network of the enamel is being attacked, and silica as well as the other enamel components are released into solution. However, the solubility of silica in acids is low. Soon, the attacking solutions will become saturated with dissolved silica and will then only leach the surface. The acid attack is inhibited and the rate of corrosion drops markedly.

NOTE The glass test equipment also releases silica by acid attack and contributes to the inhibition of the corrosion.

Inhibition is effectively prevented in vapour phase tests. The condensate formed on the test specimen is free of any dissolved enamel constituents.

Examples of enamel corrosion proceeding in a logarithmic manner [see 1)] and linearly [see 2)] are:

- 1) **Boiling citric acid** (see of ISO 28706-2:2008, Clause 10) **and boiling 30 % sulfuric acid** (see ISO 28706-2:2008, Clause 11)

Since only minor amounts of these acids are found in their vapours, the test is restricted to the liquid phase. The attack is influenced by inhibition effects, and corrosion depends on the time of exposure. Therefore, test results are expressed in terms of loss in mass per unit area; no rate of loss in mass per unit area is calculated.

- 2) **Boiling 20 % hydrochloric acid** (see ISO 28706-2:2008, Clause 12)

Since this is an azeotropic boiling acid, its concentration in the liquid and the vapour phase are identical, and liquid phase testing need not be performed. Vigorous boiling supplies an uninhibited condensate, and the attack proceeds linearly with time of exposure. Therefore,

test results are only expressed in terms of rate of loss in mass per unit area (mass loss per unit area and time) and the corrosion rate (millimetres per year).

- d) At high temperatures, with tests in the liquid phase under autoclave conditions (see ISO 28706-5), aqueous acid attack is severe. To avoid inhibition, the test time is restricted to 24 h and the ratio of attacking acid to attacked enamel surface is chosen so that it is comparatively high (similar to that in a chemical reaction vessel). In addition, only low-silica water is used for the preparation of test solutions. Under these conditions, attack will proceed linearly with time of exposure. Therefore, test results with 20 % hydrochloric acid (see ISO 28706-5:2010, Clause 8), artificial test solutions (see ISO 28706-5:2010, Clause 10) or process fluids (see ISO 28706-5:2010, Clause 11) are also expressed in terms of a rate of loss in mass per unit area (loss in mass per unit area and time).
- e) In boiling water (see ISO 28706-2:2008, Clause 13), the silica network is fairly stable. The enamel surface is leached and silica is dissolved only to a small extent. This type of attack is clearly represented by the vapour phase attack. In the liquid phase, some inhibition can be observed with highly resistant enamels. However, if the enamel being tested is weak, leached alkali from the enamel can raise pH-values to alkaline levels, thus increasing the attack by the liquid phase. Both liquid and vapour phase testing can give valuable information.
- f) Since the attack may or may not be linear, the results are expressed only in terms of loss in mass per unit area, and the test time should be indicated.
- g) For standard detergent solution (see ISO 28706-3:2008, Clause 9), it will not be certain whether the linear part of the corrosion curve will be reached during testing for 24 h or 168 h. Calculation of the corrosion rate is therefore not included in the test report.
- h) For other acids (see ISO 28706-2:2008, Clause 14) and other alkaline solutions (see ISO 28706-3:2008, Clause 10 and [Clause 11](#) of this part of ISO 28706), it will also not be known if a linear corrosion rate will be reached during the test period. Calculation of the corrosion rate is therefore not included in the test reports of those parts of this International Standard.

For vitreous enamels fired at temperatures below 700 °C, the test parameters (media, temperatures and times) of this part of ISO 28706 are not appropriate. For such enamels, for example aluminium enamels, other media, temperatures and/or times should be used. This can be done following the procedures described in the clauses for “Other test solutions” in Parts 1, 2, 3 and 4 of this International Standard.

Vitreous and porcelain enamels — Determination of resistance to chemical corrosion —

Part 4:

Determination of resistance to chemical corrosion by alkaline liquids using a cylindrical vessel

WARNING — This document calls for the use of substances and/or procedures that may be injurious to health if adequate safety measures are not taken. This document does not address any health hazards, safety or environmental matters associated with its use. It is the responsibility of the user of this document to establish appropriate health, safety and environmentally acceptable practices and take suitable actions for any national and International regulations. Compliance with this document does not of itself confer immunity from legal obligations.

1 Scope

This part of ISO 28706 describes a test method for the determination of the resistance of vitreous and porcelain enamelled articles to attack by alkaline liquids at temperatures between 25 °C and 95 °C. The apparatus used is a cylindrical vessel in which only one enamelled specimen is tested.

NOTE 1 The test method was initially set up for determination of the resistance of vitreous and porcelain enamels to a hot sodium hydroxide solution. Within the scope of this part of ISO 28706, the resistance of other alkaline liquids can be tested.

NOTE 2 This part of ISO 28706, which uses a cylindrical vessel, is generally used for tests carried out on vitreous and porcelain enamel coatings for the chemical industry.

2 Normative references

The following documents, in whole or in part, are normatively referenced in this document and are indispensable for its application. For dated references, only the edition cited applies. For undated references, the latest edition of the referenced document (including any amendments) applies.

ISO 48, *Rubber, vulcanized or thermoplastic — Determination of hardness (hardness between 10 IRHD and 100 IRHD)*

ISO 1042, *Laboratory glassware — One-mark volumetric flasks*

ISO 3696, *Water for analytical laboratory use — Specification and test methods*

ISO 28764, *Vitreous and porcelain enamels — Production of specimens for testing enamels on sheet steel, sheet aluminium and cast iron*

EN 10088-1, *Stainless steels — Part 1: List of stainless steels*

3 Principle

An enamelled specimen is exposed to attack by an alkaline liquid under specified conditions of temperature and time. The solution is not stirred during the test.

The loss in mass is determined and used to calculate the rate of loss in mass per unit area and, if necessary, the corrosion rate.

4 Reagents

During the determination, use only reagents of recognized analytical grade, unless otherwise specified.

4.1 Water, conforming to the requirements of grade 3 of ISO 3696, i.e. distilled water or water of equivalent purity.

4.2 Acetic acid solution, 50 ml/l, for cleaning the test specimens.

4.3 Degreasing solvent, such as ethanol (C₂H₅OH), or water containing a few drops of liquid detergent, suitable for cleaning and degreasing the test specimens.

4.4 Sodium hydroxide (NaOH).

5 Apparatus and material

5.1 Test apparatus: cylindrical vessel.

5.1.1 General

The assembled test apparatus is shown in [Figure 1](#). It is composed of the cylinder with the following welded-on elements as shown in [Figure 2](#):

- a plate on one end;
- a circular flange with six welded-on threaded bolts at the other end;
- a foot at the end remote from the circular flange;
- two lifting rings;
- a filling nozzle.

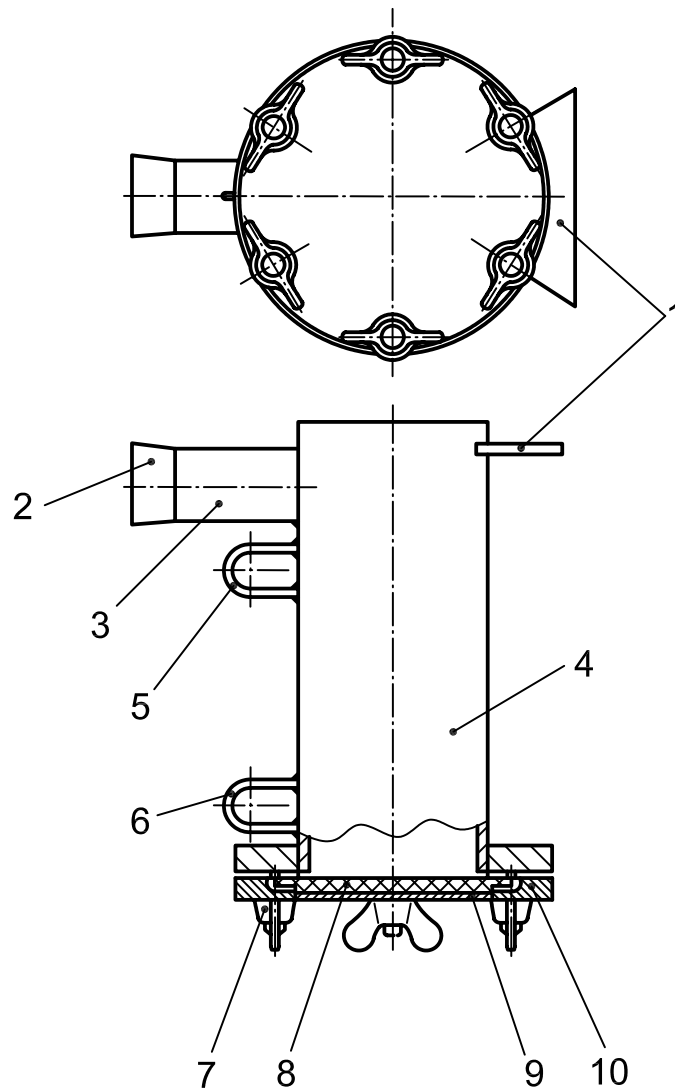

Key

- | | | | |
|---|----------------|----|---------------------|
| 1 | foot | 6 | lifting ring |
| 2 | stopper | 7 | wing nut |
| 3 | filling nozzle | 8 | test specimen |
| 4 | cylinder | 9 | protective envelope |
| 5 | lifting ring | 10 | flange plate |

Figure 1 — Test apparatus

The cylinder is sealed by the flange plate and a specimen which is enclosed in a protective envelope and put between the cylinder and the flange plate. The flange plate is fastened to the circular flange by means of six wing nuts. The filling nozzle is closed with a stopper.

The height of the foot depends on the outer diameter of the circular flange. It shall be placed in a way that the surface of the test specimen is totally covered by the liquid if the test apparatus is filled with 1 l of the test solution and placed on a plane surface.

5.1.2 Cylinder, with all surfaces consisting of bare metal and all edges deburred. All parts shall be made of the same stainless steel, for example 1.4571 stainless steel conforming to the requirements of EN 10088-1.

NOTE The main constituents of 1.4571 steel are 16,5 % to 18,5 % Cr, 10,5 % to 13,5 % Ni, 2 % to 2,5 % Mo, maximum 0,08 % C and an addition of Ti.

5.1.3 Protective envelope, shown in [Figure 3](#), made of synthetic rubber of hardness 70 IRHD as determined in accordance with ISO 48. The material shall be resistant to alkaline solutions at 100 °C (e.g. chloroprene or ethylene-propylene).

The rubber and the circular dam usually have a thickness of 2 mm; other thicknesses can also be used, however.

Dimensions in millimetres

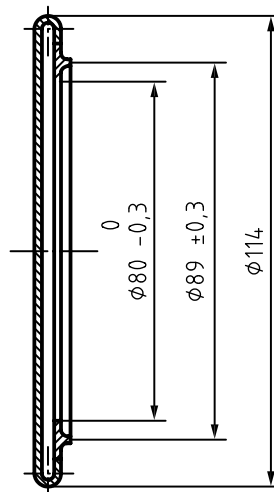

Figure 3 — Protective envelope

5.1.4 Flange plate, shown in [Figure 4](#), with all surfaces consisting of bare metal and all edges deburred. It shall be made of stainless steel, for example 1.4571 stainless steel conforming to EN 10088-1.

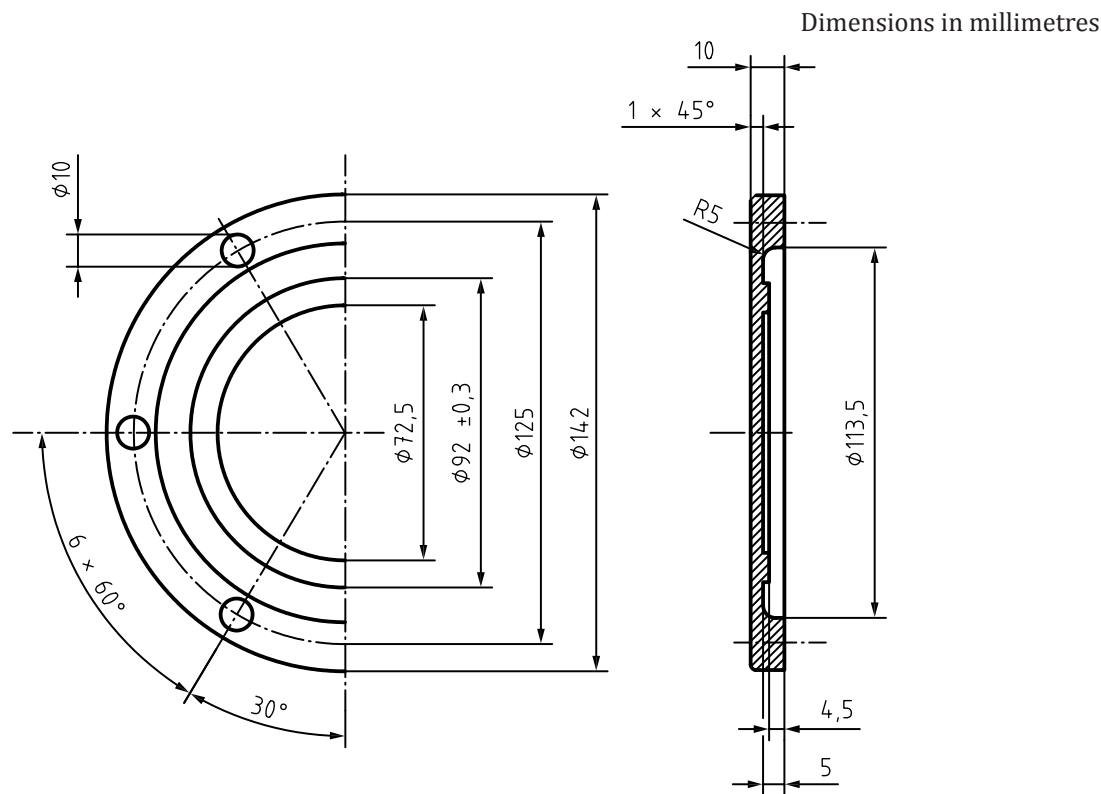

Figure 4 — Flange plate

5.1.5 Six wing nuts, with threads fitting the threaded bolts of the cylinder. They shall be made of stainless steel, for example 1.4571 stainless steel conforming to the requirements of EN 10088-1.

5.1.6 Stopper, shown in [Figure 5](#), made of synthetic rubber of hardness 70 IRHD as determined in accordance with ISO 48. The material shall be resistant to alkaline solutions at 100 °C (e.g. chloroprene or ethylene-propylene).

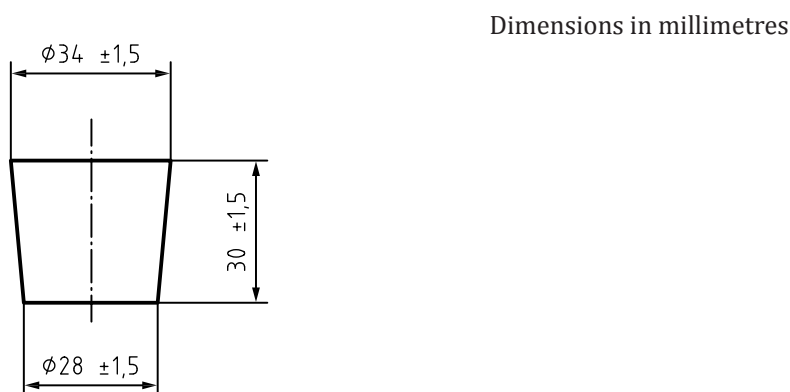

Figure 5 — Stopper

5.2 Thermostatically controlled water bath (containing demineralized or distilled water), incorporating a stirrer or other rotating device, for use with one or more pieces of test apparatus. It shall be capable of being sealed against losses by evaporation and shall allow temperatures up to 100 °C to be kept constant to 0,1 °C.

5.3 Thermometer, calibrated, graduated in 0,1 °C steps, for use with the thermostatically controlled water bath.

5.4 Drying oven, capable of maintaining temperatures of at least 130 °C.

5.5 Desiccator, with an internal diameter of at least 200 mm.

5.6 Polypropylene bottle, of 1 000 ml capacity, capable of being closed.

5.7 One-mark volumetric flask, of 1 000 ml capacity, conforming to the requirements of class A of ISO 1042.

5.8 Funnel, of maximum diameter 70 mm.

5.9 Balance, accurate to $0,2 \times 10^{-3}$ g.

5.10 Cotton wool.

6 Test specimens

Prepare the test specimens in accordance with ISO 28764.

Rinse the test specimens with water. If necessary, use a degreasing solvent (4.3). Then dry them for 2 h in the drying oven (5.4) at $110 \text{ °C} \pm 5 \text{ °C}$. Allow the specimens to stand for at least 2 h in the desiccator (see 5.5) and, finally, weigh each to the nearest $0,2 \times 10^{-3}$ g. Record the starting mass, m_s .

7 Procedure

Test at least two specimens. Carry out one determination for each test specimen.

Place a test specimen in the protective envelope (5.1.3) such that the face with the enamel coating faces the opening in the envelope.

Fix the test specimen in the test apparatus such that the side with the unprotected enamel coating faces the interior of the apparatus.

Screw down the wing nuts (5.1.5) evenly so that the test apparatus is watertight.

NOTE Damage to the enamel on weak or distorted test specimens in the apparatus can be avoided by placing a rubber ring between the protective envelope and the flange plate of the apparatus. 2 mm to 3 mm thick rubber rings made of heat-resistant rubber are suitable for this purpose (inside diameter 80 mm, outside diameter 100 mm, Shore hardness A/70/1 as determined in accordance with ISO 868).

Place the sealed test apparatus in the thermostatically controlled water bath (5.2), heated to the specified temperature (see Clauses 9, 10 and 11), such that the filling nozzle projects out of the water bath by about 10 mm. Leave the test apparatus in this position for at least 10 min before filling it with the test solution.

The test apparatus can also be placed in the cold thermostatically controlled water bath and heated to the specified temperature.

Heat about 1 000 ml of the test solution (see Clauses 9, 10 and 11) to the required temperature (see Clauses 9, 10 and 11) in the polypropylene bottle (5.6) and then pour 1 000 ml of it through the funnel (5.8) into the test apparatus which is still in the thermostatically controlled water bath. Then seal the cylinder of the test apparatus with the stopper and cover the opening of the water bath.

With its bulb close to the test apparatus in the water bath at half the height of the test apparatus, use the thermometer (5.3) to check that the test temperature is maintained throughout the test. If two or more pieces of test apparatus are used, place the thermometer between them.

When the specified test period (see Clauses 9, 10 and 11) has elapsed, remove the test apparatus from the bath using hooks, pour away the test solution and rinse the interior of the test apparatus with water (4.1).

Take the test specimen out of the protective envelope and wipe it three times with cotton wool (5.10) soaked in cold acetic acid solution (4.2), then rinse it with cold water (4.1).

Carefully remove any residues of the protective envelope from the test specimen, then dry the latter for 2 h in the drying oven (5.4) at $110\text{ °C} \pm 5\text{ °C}$.

After a further 2 h in the desiccator (5.5), weigh the test specimen to the nearest $0,2 \times 10^{-3}\text{ g}$ and record the final mass, m_f .

Calculate the arithmetic mean value of three measurements of the diameter of areas exposed to attack. The individual values shall not differ from the mean value by more than $\pm 1\text{ mm}$. Calculate the exposed area of attack, A , using this mean value of the diameter.

8 Expression of results

8.1 Total loss in mass per unit area

Calculate the total loss in mass per unit area for the total duration of the test, $\Delta\rho_A$, expressed in g/m^2 , using Formula (1):

$$\Delta\rho_A = \frac{(m_s - m_f)}{A} \quad (1)$$

where

m_s is the starting mass, in g;

m_f is the final mass, in g;

A is the area exposed to attack, in m^2 .

In order to distinguish between the test results for different test periods, the number of test hours shall be stated as a subscript to the symbol; for example, for a test period of 24 h, $\Delta\rho_{A24}$.

Results for test specimens which show defects such as pinholes down to the metal, chipped edges or edge corrosion shall be discarded and a corresponding number of new specimens shall be tested.

Express the result as the arithmetic mean of the individual values to the nearest $0,1\text{ g}/\text{m}^2$. The individual values shall not differ from the mean value by more than 20 %.

8.2 Corrosion rate

For the sodium hydroxide test (see Clause 9), the corrosion of the enamel proceeds linearly with time. The corrosion rate, v , expressed as the rate of loss in mass per unit area, $\text{g}\cdot\text{m}^{-2}\cdot\text{h}^{-1}$, is calculated from Formula (2):

$$v = \frac{\Delta\rho_A}{t} \quad (2)$$

where t is the test time, in h.

Calculate the corrosion rate, w , in mm per year from Formula (3):

$$w = 3,504v \quad (3)$$

NOTE In Formula (3), it is assumed that enamel is a homogeneous material (without gas bubbles) with a density of 2,5 g/cm³.

Express the result as the arithmetic mean of the individual values, in millimetres per year, to the nearest 0,01 mm/year.

9 Hot 0,1 mol/l sodium hydroxide test

9.1 General

Carry out this test following the procedure described in [Clause 7](#).

9.2 Test solution, $c(\text{NaOH}) = 0,1 \text{ mol/l}$

Dissolve 4 g of NaOH in water ([4.1](#)) which is free of carbon dioxide and make up to 1 l with the same water.

Use a fresh solution for each test.

NOTE When preparing the test solution, it is advisable to use a standard phial with 4 g of NaOH. The standard phial is placed in the mouth of a one-mark volumetric flask ([5.7](#)) and the upper and lower membranes of the phial are tapped with a blunt glass rod to allow the standard solution to drop into the flask. The glass rod and the phial are rinsed with water ([4.1](#)) which is free of carbon dioxide, adding the rinsings to the flask, and the solution made up to 1 l.

9.3 Test temperature

The test temperature shall be 80 °C ± 1 °C.

9.4 Duration of the test

The heating time at 80 °C shall be 24 h.

9.5 Test report

The test report shall include the following information:

- a) all information necessary for the identification of the sample tested;
- b) a reference to [Clause 9](#) of this part of ISO 28706, e.g.
“Tested in accordance with ISO 28706-4:2016, Clause 9 — Hot 0,1 mol/l sodium hydroxide”;
- c) the results, giving
 - 1) the loss in mass per unit area, $\Delta\rho_{A24}$, as calculated (see [8.1](#)), in grams per square metre, for each individual determination, plus the arithmetic mean, rounded to the nearest 0,1 g/m²,
 - 2) the rate of loss in mass per unit area (see [8.2](#)), in grams per square metre per hour, for each individual determination, plus the arithmetic mean, rounded to the nearest $1 \times 10^{-3} \text{ g}/(\text{m}^2\cdot\text{h})$, and
 - 3) the corrosion rate (see [8.2](#)), in millimetres per year, rounded to the nearest 0,01 mm/year;
- d) any deviations from the procedure specified;
- e) any unusual features observed during the test;

f) the date of the test.

10 Hot 1,0 mol/l sodium hydroxide test

10.1 General

Carry out this test following the procedure described in [Clause 7](#).

10.2 Test solution, $c(\text{NaOH}) = 1,0 \text{ mol/l}$

Dissolve 40 g of NaOH in water ([4.1](#)) which is free of carbon dioxide and make up to 1 l with the same water.

Use a fresh solution for each test.

NOTE When preparing the test solution, it is advisable to use a standard phial with 40 g of NaOH. The standard phial is placed in the mouth of a one-mark volumetric flask ([5.7](#)) and the upper and lower membranes of the phial are tapped with a blunt glass rod to allow the standard solution to drop into the flask. The glass rod and the phial are rinsed with water ([4.1](#)) which is free of carbon dioxide, adding the rinsings to the flask, and the solution made up to 1 l.

10.3 Test temperature

The test temperature shall be $80 \text{ }^\circ\text{C} \pm 1 \text{ }^\circ\text{C}$.

10.4 Duration of the test

The heating time at $80 \text{ }^\circ\text{C}$ shall be 24 h.

10.5 Test report

The test report shall include the following information:

- a) all information necessary for the identification of the sample tested;
- b) a reference to [Clause 10](#) of this part of ISO 28706, e.g.
“Tested in accordance with ISO 28706-4:2016, Clause 10 — Hot 1,0 mol/l sodium hydroxide”;
- c) the results, giving
 - 1) the loss in mass per unit area, $\Delta\rho_{A24}$, as calculated (see [8.1](#)), in grams per square metre, for each individual determination, plus the arithmetic mean, rounded to the nearest $0,1 \text{ g/m}^2$,
 - 2) the rate of loss in mass per unit area (see [8.2](#)), in grams per square metre per hour, for each individual determination, plus the arithmetic mean, rounded to the nearest $1 \times 10^{-3} \text{ g}/(\text{m}^2\cdot\text{h})$, and
 - 3) the corrosion rate (see [8.2](#)), in millimetres per year, rounded to the nearest $0,01 \text{ mm/year}$;
- d) any deviations from the procedure specified;
- e) any unusual features observed during the test;
- f) the date of the test.

11 Other test solutions

11.1 General

Carry out this test following the procedure described in [Clause 7](#).

11.2 Test solution

Prepare an agreed test solution using water ([4.1](#)) and reagents of analytical grade. No test solutions may be used that could damage the apparatus.

11.3 Test temperature

The test temperature shall be agreed and included in the test report.

11.4 Duration of the test

The heating time at the test temperature shall be included in the test report.

11.5 Test report

The test report shall include the following information:

- a) all information necessary for the identification of the sample tested;
- b) a reference to [Clause 11](#) of this part of ISO 28706, e.g.
“Tested in accordance with ISO 28706-4:2016, Clause 11 — Other test solutions”;
- c) a description of the test solution;
- d) the temperature at which the test was performed, in °C;
- e) the duration of the test, in hours;
- f) the results, giving
 - 1) the loss in mass per unit area as calculated for the time period over which testing was conducted (see [8.1](#)), in grams per square metre, for each individual determination, plus the arithmetic mean, rounded to the nearest 0,1 g/m², and
 - 2) if necessary, the rate of loss in mass per unit area and the corrosion rate (see [8.2](#)), also for each individual determination, plus the arithmetic mean, rounded to the nearest 1×10^{-3} g/(m²·h) and 0,01 mm/year, respectively;
- g) any deviations from the procedure specified;
- h) any unusual features observed during the test;
- i) the date of the test.

Bibliography

- [1] ISO 868, *Plastics and ebonite — Determination of indentation hardness by means of a durometer (Shore hardness)*

British Standards Institution (BSI)

BSI is the national body responsible for preparing British Standards and other standards-related publications, information and services.

BSI is incorporated by Royal Charter. British Standards and other standardization products are published by BSI Standards Limited.

About us

We bring together business, industry, government, consumers, innovators and others to shape their combined experience and expertise into standards-based solutions.

The knowledge embodied in our standards has been carefully assembled in a dependable format and refined through our open consultation process. Organizations of all sizes and across all sectors choose standards to help them achieve their goals.

Information on standards

We can provide you with the knowledge that your organization needs to succeed. Find out more about British Standards by visiting our website at bsigroup.com/standards or contacting our Customer Services team or Knowledge Centre.

Buying standards

You can buy and download PDF versions of BSI publications, including British and adopted European and international standards, through our website at bsigroup.com/shop, where hard copies can also be purchased.

If you need international and foreign standards from other Standards Development Organizations, hard copies can be ordered from our Customer Services team.

Subscriptions

Our range of subscription services are designed to make using standards easier for you. For further information on our subscription products go to bsigroup.com/subscriptions.

With **British Standards Online (BSOL)** you'll have instant access to over 55,000 British and adopted European and international standards from your desktop. It's available 24/7 and is refreshed daily so you'll always be up to date.

You can keep in touch with standards developments and receive substantial discounts on the purchase price of standards, both in single copy and subscription format, by becoming a **BSI Subscribing Member**.

PLUS is an updating service exclusive to BSI Subscribing Members. You will automatically receive the latest hard copy of your standards when they're revised or replaced.

To find out more about becoming a BSI Subscribing Member and the benefits of membership, please visit bsigroup.com/shop.

With a **Multi-User Network Licence (MUNL)** you are able to host standards publications on your intranet. Licences can cover as few or as many users as you wish. With updates supplied as soon as they're available, you can be sure your documentation is current. For further information, email bsmusales@bsigroup.com.

Revisions

Our British Standards and other publications are updated by amendment or revision.

We continually improve the quality of our products and services to benefit your business. If you find an inaccuracy or ambiguity within a British Standard or other BSI publication please inform the Knowledge Centre.

Copyright

All the data, software and documentation set out in all British Standards and other BSI publications are the property of and copyrighted by BSI, or some person or entity that owns copyright in the information used (such as the international standardization bodies) and has formally licensed such information to BSI for commercial publication and use. Except as permitted under the Copyright, Designs and Patents Act 1988 no extract may be reproduced, stored in a retrieval system or transmitted in any form or by any means – electronic, photocopying, recording or otherwise – without prior written permission from BSI. Details and advice can be obtained from the Copyright & Licensing Department.

Useful Contacts:

Customer Services

Tel: +44 845 086 9001

Email (orders): orders@bsigroup.com

Email (enquiries): cservices@bsigroup.com

Subscriptions

Tel: +44 845 086 9001

Email: subscriptions@bsigroup.com

Knowledge Centre

Tel: +44 20 8996 7004

Email: knowledgecentre@bsigroup.com

Copyright & Licensing

Tel: +44 20 8996 7070

Email: copyright@bsigroup.com

BSI Group Headquarters

389 Chiswick High Road London W4 4AL UK

