



BSI Standards Publication

Vitreous and porcelain enamels — Determination of resistance to chemical corrosion

Part 2: Determination of resistance to chemical corrosion by boiling acids, boiling neutral liquids, alkaline liquids and/or their vapours (ISO 28706-2:2017)

National foreword

This British Standard is the UK implementation of EN ISO 28706-2:2017. It supersedes BS EN ISO 28706-2:2011 which is withdrawn.

The UK participation in its preparation was entrusted to Technical Committee STI/36, Vitreous enamel coatings.

A list of organizations represented on this committee can be obtained on request to its secretary.

This publication does not purport to include all the necessary provisions of a contract. Users are responsible for its correct application.

© The British Standards Institution 2017.
Published by BSI Standards Limited 2017

ISBN 978 0 580 85101 8

ICS 25.220.50

Compliance with a British Standard cannot confer immunity from legal obligations.

This British Standard was published under the authority of the Standards Policy and Strategy Committee on 31 March 2017.

Amendments/corrigenda issued since publication

Date	Text affected
------	---------------

English Version

Vitreous and porcelain enamels - Determination of
resistance to chemical corrosion - Part 2: Determination of
resistance to chemical corrosion by boiling acids, boiling
neutral liquids, alkaline liquids and/or their vapours (ISO
28706-2:2017)

Émaux vitrifiés - Détermination de la résistance à la
corrosion chimique - Partie 2: Détermination de la
résistance à la corrosion chimique par des acides
bouillants, des liquides neutres bouillants, ou des
liquides alcalins et/ou leurs vapeurs (ISO 28706-
2:2017)

Emails und Emaillierungen - Bestimmung der
Beständigkeit gegen chemische Korrosion - Teil 2:
Bestimmung der Beständigkeit gegen chemische
Korrosion durch kochende Säuren, kochende neutrale
Flüssigkeiten, alkalische Flüssigkeiten und/oder deren
Dämpfe (ISO 28706-2:2017)

This European Standard was approved by CEN on 28 February 2017.

CEN members are bound to comply with the CEN/CENELEC Internal Regulations which stipulate the conditions for giving this European Standard the status of a national standard without any alteration. Up-to-date lists and bibliographical references concerning such national standards may be obtained on application to the CEN-CENELEC Management Centre or to any CEN member.

This European Standard exists in three official versions (English, French, German). A version in any other language made by translation under the responsibility of a CEN member into its own language and notified to the CEN-CENELEC Management Centre has the same status as the official versions.

CEN members are the national standards bodies of Austria, Belgium, Bulgaria, Croatia, Cyprus, Czech Republic, Denmark, Estonia, Finland, Former Yugoslav Republic of Macedonia, France, Germany, Greece, Hungary, Iceland, Ireland, Italy, Latvia, Lithuania, Luxembourg, Malta, Netherlands, Norway, Poland, Portugal, Romania, Serbia, Slovakia, Slovenia, Spain, Sweden, Switzerland, Turkey and United Kingdom.



EUROPEAN COMMITTEE FOR STANDARDIZATION
COMITÉ EUROPÉEN DE NORMALISATION
EUROPÄISCHES KOMITEE FÜR NORMUNG

CEN-CENELEC Management Centre: Avenue Marnix 17, B-1000 Brussels

European foreword

This document (EN ISO 28706-2:2017) has been prepared by Technical Committee ISO/TC 107 "Metallic and other inorganic coatings" in collaboration with Technical Committee CEN/TC 262 "Metallic and other inorganic coatings" the secretariat of which is held by BSI.

This European Standard shall be given the status of a national standard, either by publication of an identical text or by endorsement, at the latest by September 2017 and conflicting national standards shall be withdrawn at the latest by September 2017.

Attention is drawn to the possibility that some of the elements of this document may be the subject of patent rights. CEN [and/or CENELEC] shall not be held responsible for identifying any or all such patent rights.

This document supersedes EN ISO 28706-2:2011.

According to the CEN-CENELEC Internal Regulations, the national standards organizations of the following countries are bound to implement this European Standard: Austria, Belgium, Bulgaria, Croatia, Cyprus, Czech Republic, Denmark, Estonia, Finland, Former Yugoslav Republic of Macedonia, France, Germany, Greece, Hungary, Iceland, Ireland, Italy, Latvia, Lithuania, Luxembourg, Malta, Netherlands, Norway, Poland, Portugal, Romania, Serbia, Slovakia, Slovenia, Spain, Sweden, Switzerland, Turkey and the United Kingdom.

Endorsement notice

The text of ISO 28706-2:2017 has been approved by CEN as EN ISO 28706-2:2017 without any modification.

Contents

	Page
Foreword	v
Introduction	vi
1 Scope	1
2 Normative references	1
3 Terms and definitions	1
4 Principle	2
5 Reagents	2
6 Apparatus and materials	3
6.1 Test apparatus	3
6.2 Test materials	8
7 Packing rings	8
7.1 General	8
7.2 Packing A	8
7.3 Packing B	9
8 Test specimens	9
9 Procedure	9
10 Expression of results	10
10.1 Total loss in mass per unit area	10
10.2 Corrosion rate	10
11 Boiling citric acid	11
11.1 General	11
11.2 Test solution	11
11.3 Duration of the test	11
11.4 Test report	11
12 Boiling sulfuric acid	11
12.1 General	11
12.2 Test solution	11
12.3 Duration of the test	12
12.4 Test report	12
13 Boiling hydrochloric acid	12
13.1 General	12
13.2 Test solution	12
13.3 Duration of the test	12
13.4 Test report	13
14 Boiling distilled or demineralized water	13
14.1 General	13
14.2 Test solution	13
14.3 Duration of the test	13
14.4 Test report	14
15 Standard detergent solution	14
15.1 General	14
15.2 Test solution	14
15.3 Test temperature	15
15.4 Duration of the test	15
15.5 Test report	15
16 Other test solutions and/or conditions	15
16.1 General	15

16.2	Test solution.....	15
16.3	Duration of the test.....	15
16.4	Test report.....	16
Bibliography		17

Foreword

ISO (the International Organization for Standardization) is a worldwide federation of national standards bodies (ISO member bodies). The work of preparing International Standards is normally carried out through ISO technical committees. Each member body interested in a subject for which a technical committee has been established has the right to be represented on that committee. International organizations, governmental and non-governmental, in liaison with ISO, also take part in the work. ISO collaborates closely with the International Electrotechnical Commission (IEC) on all matters of electrotechnical standardization.

The procedures used to develop this document and those intended for its further maintenance are described in the ISO/IEC Directives, Part 1. In particular the different approval criteria needed for the different types of ISO documents should be noted. This document was drafted in accordance with the editorial rules of the ISO/IEC Directives, Part 2 (see www.iso.org/directives).

Attention is drawn to the possibility that some of the elements of this document may be the subject of patent rights. ISO shall not be held responsible for identifying any or all such patent rights. Details of any patent rights identified during the development of the document will be in the Introduction and/or on the ISO list of patent declarations received (see www.iso.org/patents).

Any trade name used in this document is information given for the convenience of users and does not constitute an endorsement.

For an explanation on the voluntary nature of standards, the meaning of ISO specific terms and expressions related to conformity assessment, as well as information about ISO's adherence to the World Trade Organization (WTO) principles in the Technical Barriers to Trade (TBT) see the following URL: www.iso.org/iso/foreword.html.

This document was prepared by Technical Committee ISO/TC 107, *Metallic and other inorganic coatings*.

This second edition cancels and replaces the first edition (ISO 28706-2:2008), which has been technically revised with changes as follows.

- This document can also be used to determine resistance to chemical corrosion using alkaline liquids. The title of this document has therefore been amended and a section on standard detergent solutions has been included.
- Additional reagents can be used for testing purposes and these have been included.

A list of all parts in the ISO 28706 series can be found on the ISO website.

Introduction

Corrosion of vitreous and porcelain enamels by aqueous solutions is a dissolution process. The main component of the enamel, SiO₂, forms a three-dimensional silica network. After hydrolysis, it decomposes and forms silicic acid or silicates. These are released into the attacking medium. Other components, mainly metal oxides, are hydrolysed as well and form the corresponding hydrated metal ions or hydroxides. All corrosion products are more or less soluble in the attacking medium. The whole process results in a loss in mass per unit area.

For some aqueous solutions, the attack on the enamel proceeds linearly during the corrosion time; for other aqueous solutions, the attack on the enamel proceeds in a logarithmic manner during the corrosion time. Only for the first series of solutions can a scientifically exact rate of loss in mass per unit area (g/m²·h) be calculated as well as a corrosion rate (millimetres per year).

The most important parameters influencing aqueous corrosion of the enamel are the enamel quality, the temperature and the pH value. Inhibition effects resulting from the limited solubility of silica can also contribute. The following list describes different types of enamel attack for different corrosion conditions.

- a) In aqueous alkali solutions such as 0,1 mol/l NaOH (see ISO 28706-4:2016, Clause 9), the silica network of the enamel is considerably attacked at 80 °C. Silicates and most of the other hydrolysed components are soluble in the alkali. Attack proceeds linearly during regular test times. Therefore, test results are expressed in terms of a rate of loss in mass per unit area (mass loss per unit area and time) and a corrosion rate (millimetres per year).
- b) At room temperature, in weak aqueous acids such as citric acid (see ISO 28706-1:2008, Clause 9) or also in stronger acids such as sulfuric acid (see ISO 28706-1:2008, Clause 10), there is only minor attack on the silica network of the enamel. Other constituents are leached to some extent from the surface. Highly resistant enamels will show no visual change after exposure. On less resistant enamels, some staining or surface roughening will occur.
- c) In boiling aqueous acids (as described in this document), the silica network of the enamel is being attacked, and silica as well as the other enamel components are released into solution. However, the solubility of silica in acids is low. Soon, the attacking solutions will become saturated with dissolved silica and will then only leach the surface. The acid attack is inhibited and the rate of corrosion drops markedly.

NOTE The glass test equipment also releases silica by acid attack and contributes to the inhibition of the corrosion.

Inhibition is effectively prevented in vapour phase tests. The condensate formed on the test specimen is free of any dissolved enamel constituents.

Examples of enamel corrosion proceeding in a logarithmic manner [see 1)] and linearly [see 2)] are as follows:

- 1) **Boiling citric acid** (see [Clause 11](#)) and **boiling 30 % sulfuric acid** (see [Clause 12](#)).

Since only minute amounts of these acids are found in their vapours, the test is restricted to the liquid phase. The attack is influenced by inhibition effects and corrosion depends on the time of exposure. Therefore, test results are expressed in terms of loss in mass per unit area; no rate of loss in mass per unit area is calculated.

- 2) **Boiling 20 % hydrochloric acid** (see [Clause 13](#)).

Since this is an azeotropic boiling acid, its concentration in the liquid and the vapour phase are identical, and liquid phase testing need not be performed. Vigorous boiling supplies an uninhibited condensate, and the attack proceeds linearly with time of exposure. Therefore,

test results are only expressed in terms of rate of loss in mass per unit area (mass loss per unit area and time) and the corrosion rate (millimetres per year).

- d) At high temperatures, with tests in the liquid phase under autoclave conditions (see ISO 28706-5), aqueous acid attack is severe. To avoid inhibition, the test time is restricted to 24 h and the ratio of attacking acid to attacked enamel surface is chosen so that it is comparatively high (similar to that in a chemical reaction vessel). In addition, only low-silica water is used for the preparation of test solutions. Under these conditions, attack will proceed linearly with time of exposure. Therefore, test results with 20 % hydrochloric acid (see ISO 28706-5:2010, Clause 8), artificial test solutions (see ISO 28706-5:2010, Clause 10) or process fluids (see ISO 28706-5:2010, Clause 11) are also expressed in terms of a rate of loss in mass per unit area (loss in mass per unit area and time).
- e) In boiling water (see [Clause 14](#)), the silica network is fairly stable. The enamel surface is leached and silica is dissolved only to a small extent. This type of attack is clearly represented by the vapour phase attack. In the liquid phase, some inhibition can be observed with highly resistant enamels. However, if the enamel being tested is weak, leached alkali from the enamel can raise pH values to alkaline levels, thus increasing the attack by the liquid phase. Both liquid and vapour phase testing can give valuable information.
- f) Since the attack may or may not be linear, the results are expressed only in terms of loss in mass per unit area and the test time should be indicated.
- g) For standard detergent solution (see ISO 28706-3:2008, Clause 9), it will not be certain whether the linear part of the corrosion curve will be reached during testing for 24 h or 168 h. Calculation of the corrosion rate is therefore not included in the test report.
- h) For other acids (see [Clause 15](#)) and other alkaline solutions (see ISO 28706-3:2008, Clause 10 and ISO 28706-4:2016, Clause 10), it will also not be known if a linear corrosion rate will be reached during the test period. Calculation of the corrosion rate is therefore not included in the test reports of those parts of this document.

For vitreous enamels fired at temperatures below 700 °C, the test parameters (media, temperatures and times) of this document are not appropriate. For such enamels, for example aluminium enamels, other media, temperatures and/or times should be used. This can be done following the procedures described in the clauses for “Other test solutions” in ISO 28706-1, ISO 28706-2, ISO 28706-3 and ISO 28706-4.

Vitreous and porcelain enamels — Determination of resistance to chemical corrosion —

Part 2:

Determination of resistance to chemical corrosion by boiling acids, boiling neutral liquids, alkaline liquids and/or their vapours

WARNING — This document calls for the use of substances and/or procedures that may be injurious to health if adequate safety measures are not taken. This document does not address any health hazards, safety or environmental matters associated with its use. Is it the responsibility of the user of this document to establish appropriate health, safety and environmentally acceptable practices and take suitable actions for any national and international regulations.

1 Scope

This document specifies a test method for the determination of the resistance of flat surfaces of vitreous and porcelain enamels to boiling acids, boiling neutral liquids, alkaline liquids and/or their vapours.

This method allows the determination of the resistance of vitreous and porcelain enamels to the liquid and vapour phases of the corrosive medium simultaneously.

2 Normative references

The following documents are referred to in the text in such a way that some or all of their content constitutes requirements of this document. For dated references, only the edition cited applies. For undated references, the latest edition of the referenced document (including any amendments) applies.

ISO 48, *Rubber, vulcanized or thermoplastic — Determination of hardness (hardness between 10 IRHD and 100 IRHD)*

ISO 649-1, *Laboratory glassware — Density hydrometers for general purposes — Part 1: Specification*

ISO 718, *Laboratory glassware — Thermal shock and thermal shock endurance — Test methods*

ISO 3585, *Borosilicate glass 3.3 — Properties*

ISO 3696, *Water for analytical laboratory use — Specification and test methods*

ISO 4788, *Laboratory glassware — Graduated measuring cylinders*

ISO 4799, *Laboratory glassware — Condensers*

ISO 28764, *Vitreous and porcelain enamels — Production of specimens for testing enamels on sheet steel, sheet aluminium and cast iron*

3 Terms and definitions

No terms and definitions are defined in this document.

ISO and IEC maintain terminological databases for use in standardization at the following addresses:

— IEC Electropedia: available at <http://www.electropedia.org/>

— ISO Online browsing platform: available at <http://www.iso.org/obp>

4 Principle

A set of similarly enamelled test specimens is placed in the liquid zone and/or in the vapour zone of the test apparatus, as required, and exposed to attack by a boiling acid or boiling neutral liquid, or its vapour, under specified conditions.

The same design of test apparatus and the same test principle is employed for the different liquids.

The loss in mass is determined and used to calculate the rate of loss in mass per unit area and, if necessary, the corrosion rate.

5 Reagents

During the determination, use only reagents of recognized analytical grade, unless otherwise specified.

5.1 Water, conforming to the requirements of grade 3 of ISO 3696, i.e. distilled water or water of equivalent purity.

5.2 Acetic acid solution, volume concentration 50 ml/l, for cleaning the test apparatus and test specimens.

5.3 Degreasing solvent, such as ethanol, or water containing a few drops of liquid detergent, suitable for cleaning the test apparatus and test specimens.

5.4 Citric acid monohydrate, (C₆H₈O₇·H₂O), crystalline.

5.5 Sulfuric acid, analytical grade, 30 % (by mass) solution, density range 1,217 g/ml to 1,220 g/ml (measured with a hydrometer; see 6.2.7).

5.6 Hydrochloric acid, analytical grade, 20 % (by mass) solution, density range 1,097 g/ml to 1,099 g/ml (measured with a hydrometer; see 6.2.7).

5.7 Sodium tripolyphosphate (Na₅P₃O₁₀).

5.8 Sodium carbonate (Na₂CO₃), anhydrous.

5.9 Sodium perborate, hydrated (NaBO₂·H₂O₂·3H₂O).

5.10 Sodium silicate, containing about 81 % (by mass) of Na₂SiO₃.

5.11 Alkylsulfonate [CH₃(CH₂)_x - C(SO₂Na)H - (CH₂)₃ - CH₃].

6 Apparatus and materials

6.1 Test apparatus

6.1.1 The test apparatus (see [Figures 1](#) and [2](#)) consists of a cylinder ([6.1.2](#); see [Figure 3](#)), with an adjacent support, having a standard socket for holding a reflux condenser ([6.1.3](#)) with a graduated collector ([6.1.4](#)) on one side.

Two test specimens shall form the top and bottom of the cylinder. One of them may be replaced by a glass plate ([6.1.14](#)) if required. The cylinder with the specimens shall be supported between two plates (see [Figure 2](#)) locked at the corners by threaded bolts ([6.1.8](#)), wing nuts ([6.1.7](#)) and hexagonal nuts ([6.1.6](#)). A synthetic-fibre washer ([6.1.9](#)) is fixed between the plates ([6.1.5](#)) and each specimen. The specimens are sealed against the ends of the cylinder with packing rings ([6.1.10](#)), the material of which is dependent on the type of test solution. Any uncoated area of the test specimen shall be protected from exposure to the attacking medium.

When testing specimens cut from an enamelled article, the packing rings ([6.1.10](#)) are replaced by protective envelopes (see [Figure 5](#)) in which the specimens are placed.

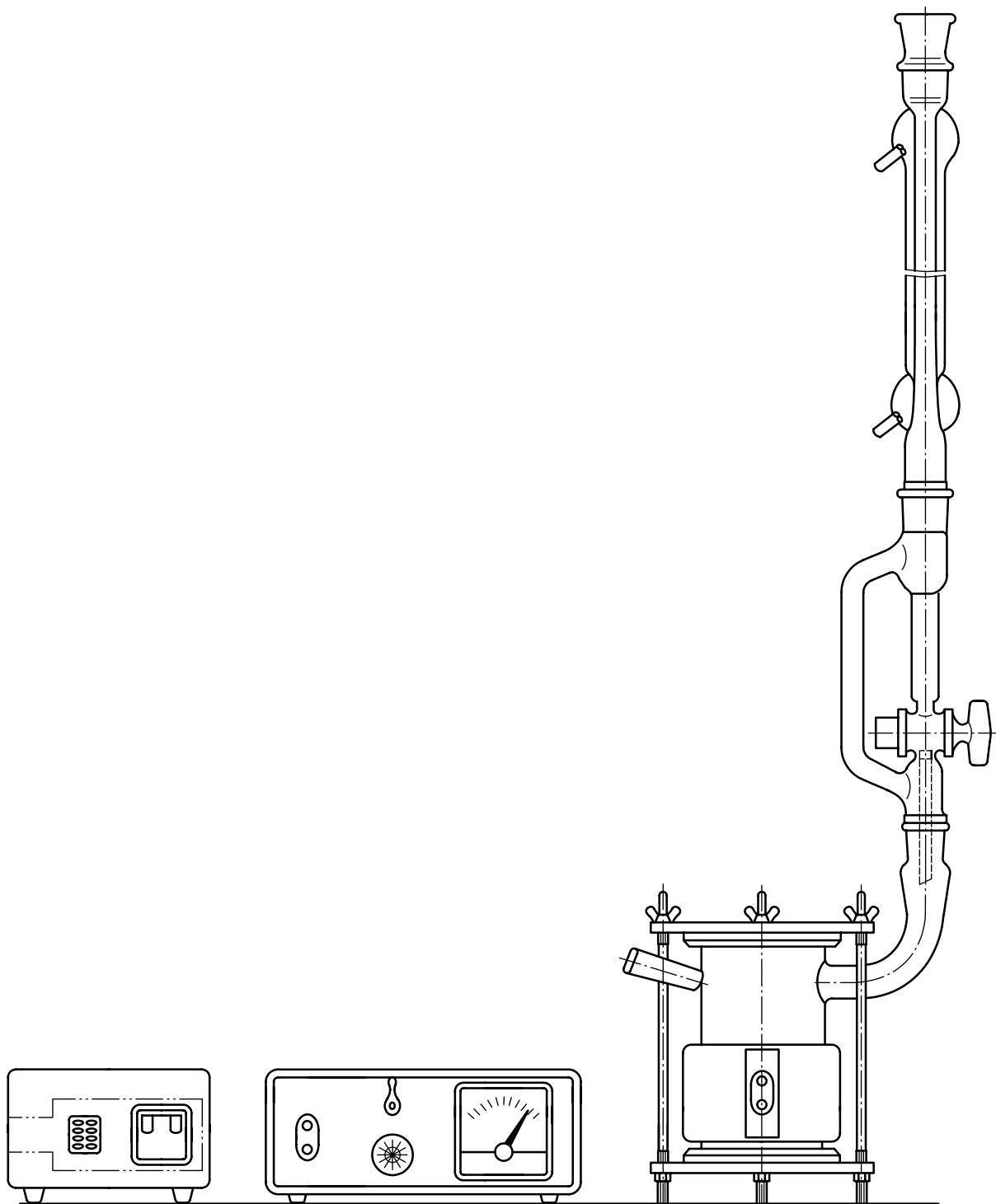
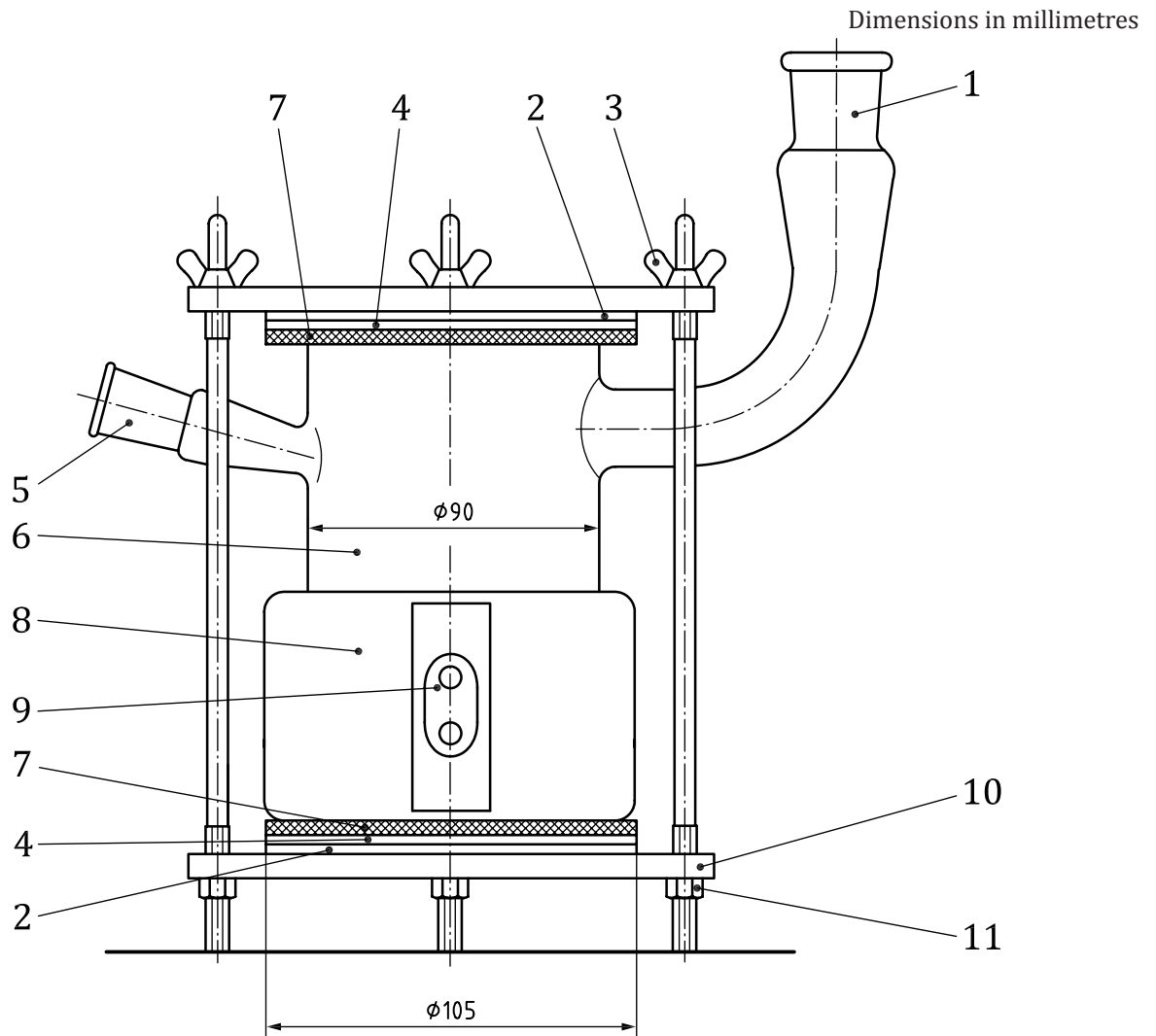

Figure 1 — View of assembled test equipment



Key

- | | | | |
|---|-----------------------------|----|------------------|
| 1 | socket for reflux condenser | 7 | packing ring |
| 2 | synthetic-fibre washer | 8 | heater |
| 3 | wing nut | 9 | electric socket |
| 4 | specimen | 10 | triangular plate |
| 5 | socket for thermometer | 11 | hexagonal nut |
| 6 | cylinder | | |

Figure 2 — Test apparatus

The apparatus is heated externally by a heater (6.1.11) placed round the lower half of the cylinder (6.1.2) such that the lower edge is, at the most, 3 mm above the lower packing ring. The test apparatus is composed of the parts described in 6.1.2 to 6.1.15.

6.1.2 Cylinder (see Figure 3), made of borosilicate glass 3.3 conforming to the requirements of ISO 3585, with ground ends. When tested in accordance with ISO 718, the cylinder shall pass the test without breaking at a difference in temperature of at least 120 °C.

NOTE Cylinders having two sockets can also be used if the smaller socket is closed by a stopper which is resistant to the boiling solution.

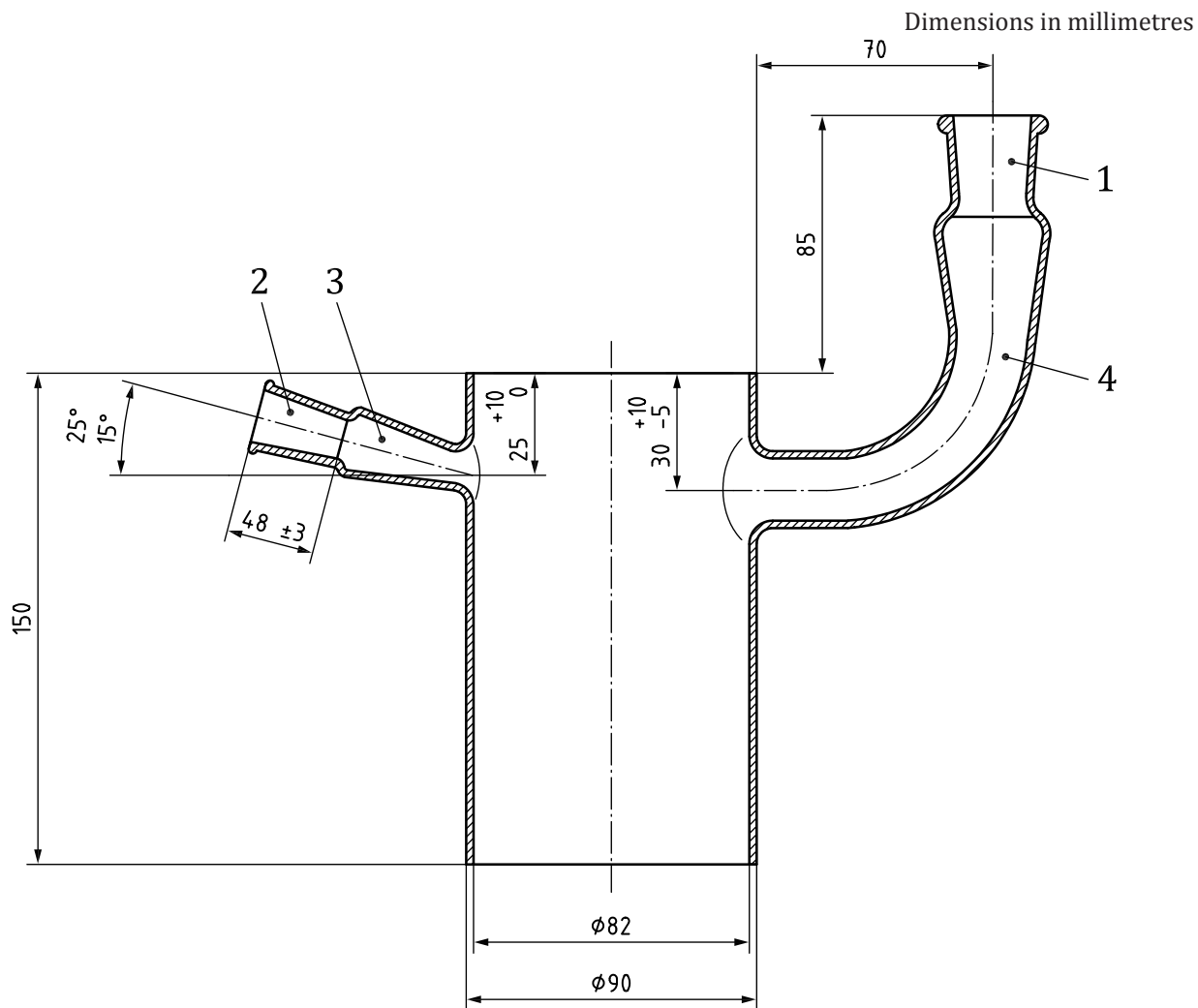

Key

- 1 ground-glass socket for condenser
- 2 ground-glass socket for thermometer
- 3 connecting piece
- 4 connecting piece

Figure 3 — Cylinder

6.1.3 Liebigh-West reflux condenser, or equivalent reflux condenser conforming to ISO 4799, in which there is no volume change during the test, with a nominal jacket length of 400 mm and standard ground joint of borosilicate glass 3.3 conforming to the requirements of ISO 3585.

6.1.4 Graduated collector (see [Figure 4](#)), with a standard ground joint of borosilicate glass 3.3 conforming to the requirements of ISO 3585, arranged in the apparatus to collect the condensate produced in the reflux condenser. The graduation interval shall be 0,1 ml.

Dimensions in millimetres

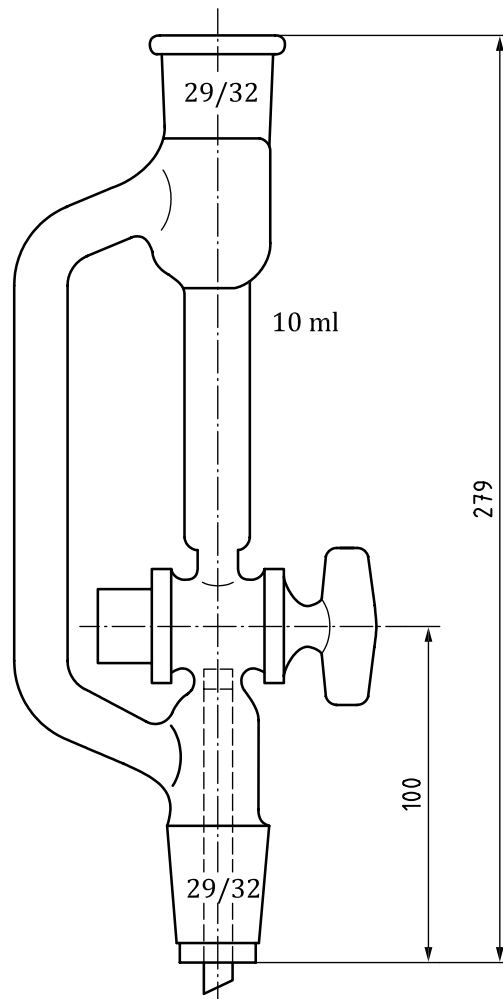

Figure 4 — Graduated collector

Dimensions in millimetres

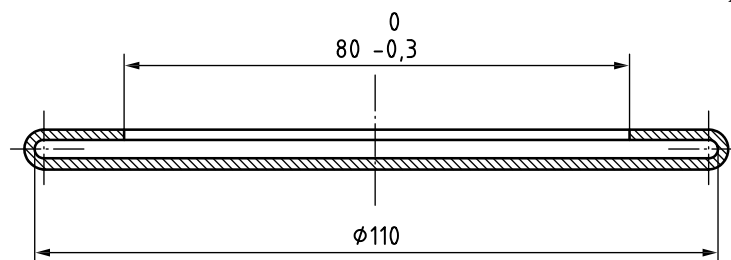

Figure 5 — Protective envelope

- 6.1.5 Two plates of surface-protected steel.
- 6.1.6 Hexagonal nuts, with a thread fitting the screw bolts.
- 6.1.7 Wing nuts, with a thread fitting the screw bolts.
- 6.1.8 Threaded bolts, of corrosion-resistant steel.

6.1.9 Synthetic-fibre washers, resistant to acid and water at 140 °C.

NOTE Polytetrafluoroethylene (PTFE) is the only plastic material suitable for tests with mineral acids (e.g. H₂SO₄, HCl).

6.1.10 Packing rings (see [Clause 7](#)).

6.1.11 Heater, with an output of 400 W to 500 W, constructed of heat-conducting alloy covered with heat-insulating material, having dimensions such that the lower edge of the heater is, at the most, 3 mm above the lower packing ring and is not in contact with it.

6.1.12 Heat-controlling device, for example a thermostat, a variable transformer or electronic control equipment.

6.1.13 Voltage stabilizer, to avoid variation in heating due to fluctuations in the power supply.

6.1.14 Glass plate, made of borosilicate glass 3.3 conforming to the requirements of ISO 3585, having a diameter of 105 mm, as cover or bottom of the cylinder, if required.

6.1.15 Simmering aid, such as floating particles resistant to the boiling solution.

NOTE 1 PTFE is the only fluorinated plastic material suitable for tests with mineral acids (e.g. H₂SO₄, HCl).

NOTE 2 When boiling with sulfuric acid, boiling retardation is best avoided by using borosilicate glass capillary tubes.

6.2 Test materials

6.2.1 Drying oven, capable of maintaining a temperature of at least 130 °C.

6.2.2 Desiccator, for example with an internal diameter of 200 mm.

6.2.3 Graduated measuring cylinder, capacity 500 ml, conforming to the requirements of ISO 4788.

6.2.4 Beakers.

6.2.5 Balance, capable of weighing to the nearest 0,2 mg.

6.2.6 Sponge, soft.

6.2.7 Graduated hydrometer, conforming to the requirements of ISO 649-1.

7 Packing rings

7.1 General

The method of holding the specimens against the ends of the cylinder depends on the type of specimen and the type of test solution. Use one of the types of packing described in [7.2](#) and [7.3](#).

7.2 Packing A

Compressed-fibre washers 100 mm in external diameter, 80 mm ± 1 mm in internal diameter and 2 mm thick, covered with a plastic material resistant to hydrochloric acid at 140 °C (e.g. PTFE).

7.3 Packing B

Packing rings 100 mm in external diameter, 80 mm \pm 0,3 mm in internal diameter and 2 mm or 3 mm thick, made of rubber with a hardness of 70 IRHD as determined in accordance with ISO 48 and resistant to citric acid and water at 140 °C (e.g. chloroprene or ethylene-propylene).

8 Test specimens

Prepare the test specimens in accordance with ISO 28764.

Rinse each test specimen with water (5.1). If necessary, use a suitable degreasing solvent (5.3). Dry each specimen for 2 h in the drying oven (6.2.1) maintained at 110 °C \pm 5 °C. Allow the specimens to stand for at least 2 h in the desiccator (6.2.2) and finally weigh each to the nearest 0,2 mg. Record the starting mass, m_s .

9 Procedure

Carry out two determinations, with new test specimens for each determination, in vapour and/or liquid.

Fix the test specimens in the test apparatus (6.1) so that the coated faces of the specimens are facing the interior of the cylinder. Protect any uncoated areas of the test specimens from exposure to the attacking medium. If the test is to be carried out only in the liquid phase, use a glass plate of borosilicate glass 3.3 (see ISO 3585) as the cover for the apparatus; if the test is to be carried out only in the vapour phase, use a glass plate of borosilicate 3.3 (see ISO 3585) as the bottom of the apparatus.

Screw down the wing nuts evenly to ensure that the test apparatus is tight to liquids.

For [Clauses 11 to 14](#), run 450 ml of the test solution into the cylinder through the socket provided for the graduated collector and mount the latter and the reflux condenser in place. Switch the heater on and bring the test solution to boiling within 15 min. The measured test period starts with the commencement of boiling. As soon as the solution is boiling vigorously, use the heat-controlling device to maintain the amount of condensate condensed in the reflux condenser and measured in the graduated collector within the range 8 ml \pm 2 ml every 3 min for the duration of the test.

For [Clause 15](#), run 450 ml of the test solution into the cylinder through the socket provided for the graduated collector and mount the latter and the reflux condenser in place, leaving the graduated collector open. Switch the heater on and bring the test solution to 95 °C \pm 2 °C within 15 min. The measured test period starts once the test temperature has been reached. Use the heat-controlling device to maintain the temperature.

The duration of the test depends on the test solution (see [Clauses 11 to 14](#)).

After heating for the prescribed period (see [Clauses 11 to 14](#)), empty the cylinder, cool it and rinse it with water (5.1).

Take the specimens from the apparatus, wipe them three times with a sponge (6.2.6) which has been soaked in acetic acid (5.2) at room temperature and then rinse with water (5.1).

After carefully removing any packing-ring residues from the edges of the specimens, dry them for 2 h in the hot-air oven (6.2.1) at 110 °C \pm 5 °C. After a further 2 h in the desiccator (6.2.2), weigh each specimen again to the nearest 0,2 mg and record the final mass, m_f . The total time from removal of a specimen from the desiccator until completion of weighing shall not exceed 2 min.

Measure the diameter of the area exposed to attack. The mean value of three measurements of the diameter of the area exposed to attack shall lie within \pm 1 mm of 80 mm. Calculate the area exposed to attack, A , using this mean value of the diameter.

10 Expression of results

10.1 Total loss in mass per unit area

For each test, calculate the total loss in mass per unit area, $\Delta\rho_A$, in g/m², for the total duration of the test using [Formula \(1\)](#):

$$\Delta\rho_A = \frac{(m_s - m_f)}{A} \quad (1)$$

where

m_s is the starting mass, in g;

m_f is the final mass, in g;

A is the area exposed to attack, in m².

In order to distinguish between test results for different test periods, the number of test hours shall be stated as a subscript to the symbol, for example:

for a test period of 2,5 h: $\Delta\rho_{A2,5}$

for a test period of 48 h: $\Delta\rho_{A48}$

Test specimens which show defects such as pinholes down to the metal, chipped edges or edge corrosion shall be discarded and a corresponding number of new specimens shall be tested.

Express the result as the arithmetic mean of the individual values to the nearest 0,1 g/m². The individual values shall not differ from the mean value by more than 20 %.

10.2 Corrosion rate

In the hydrochloric acid test (see [Clause 13](#)), the corrosion of the enamel proceeds linearly with time. The corrosion rate, v , expressed as the rate of loss in mass per unit area, g·m⁻²·h⁻¹, is calculated using [Formula \(2\)](#):

$$v = \frac{\Delta\rho_A}{t} \quad (2)$$

where

t is the test time, in h.

Calculate the corrosion rate, w , in mm per year using [Formula \(3\)](#):

$$w = 3,504v \quad (3)$$

NOTE In [Formula \(3\)](#), it is assumed that enamel is a homogeneous material (without gas bubbles) with a density of 2,5 g/cm³.

Express the result as the arithmetic mean of the individual values, in millimetres per year, to the nearest 0,01 millimetres per year.

11 Boiling citric acid

11.1 General

Carry out this test using the procedure described in [Clause 9](#).

11.2 Test solution

Dissolve 32 g of pure crystalline citric acid monohydrate ($C_6H_8O_7 \cdot H_2O$) in 500 ml of water ([5.1](#)). A fresh solution, prepared the same day, is required for each test.

Only the resistance to chemical corrosion in the liquid phase shall be assessed.

11.3 Duration of the test

The heating time, i.e. the time with the condensation rate maintained within the range $8 \text{ ml} \pm 2 \text{ ml}$ per 3 min, shall be 2,5 h (150 min).

If the loss in mass of any of the specimens after this time is less than 8 mg, the result of the test is " $<1,6 \text{ g/m}^2$ ".

If a more precise result is required, carry out another test using new specimens and another test solution and/or another test duration after testing with other test solutions and/or conditions as described in [Clause 16](#).

11.4 Test report

The test report shall include the following information:

- a) all information necessary for the identification of the sample tested;
- b) a reference to [Clause 11](#) of this document, e.g. "Tested in accordance with ISO 28706-2:2017, Clause 11";
- c) the duration of the test: 2,5 h;
- d) the results, giving the loss in mass per unit area as calculated for the time period over which testing was conducted (see [10.1](#)), in grams per square metre, for each individual determination, plus the arithmetic mean, rounded to the nearest $0,1 \text{ g/m}^2$;
- e) any deviations from the procedure specified;
- f) any unusual features observed during the test;
- g) the date of the test.

12 Boiling sulfuric acid

12.1 General

Carry out this test following the procedure described in [Clause 9](#).

12.2 Test solution

Sulfuric acid, analytical grade, 30 % (by mass) solution, density range $1,217 \text{ g/ml}$ to $1,220 \text{ g/ml}$ (measured with a hydrometer; see [6.2.7](#)). A fresh solution is required for each test.

Only the resistance to chemical corrosion in the liquid phase shall be assessed.

12.3 Duration of the test

The heating time, i.e. the time with the condensation rate maintained within the range $8 \text{ ml} \pm 2 \text{ ml}$ per 3 min, shall be 18 h.

If the loss in mass of any of the specimens after this time is less than 8 mg, the result of the test is " $<1,6 \text{ g/m}^2$ ".

If a more precise result is required, carry out another test using new specimens and another test solution and/or another test duration after testing with other test solutions and/or conditions as described in [Clause 16](#).

12.4 Test report

The test report shall include the following information:

- a) all information necessary for the identification of the sample tested;
- b) a reference to [Clause 12](#) of this document, e.g. "Tested in accordance with ISO 28706-2:2017, Clause 12";
- c) the duration of the test: 18 h;
- d) the results, giving the loss in mass per unit area as calculated for the time period over which testing was conducted (see [10.1](#)), in grams per square metre, for each individual determination, plus the arithmetic mean, rounded to the nearest $0,1 \text{ g/m}^2$;
- e) any deviations from the procedure specified;
- f) any unusual features observed during the test;
- g) the date of the test.

13 Boiling hydrochloric acid

13.1 General

Carry out this test using the procedure described in [Clause 9](#).

13.2 Test solution

Hydrochloric acid, analytical grade, 20 % (by mass) solution, density range $1,097 \text{ g/ml}$ to $1,099 \text{ g/ml}$ (measured with a hydrometer; see [6.2.7](#)). A fresh solution is required for each test.

Only the resistance to chemical corrosion in the vapour phase shall be assessed.

13.3 Duration of the test

The heating time, i.e. the time with the condensation rate maintained within the range $8 \text{ ml} \pm 2 \text{ ml}$ per 3 min, shall be 7 d.

If the loss in mass of any of the specimens after this time is less than 8 mg, carry out the test with new specimens and a heating time of 14 d. If the loss in mass is still less than 8 mg, the result of the test is " $<1,6 \text{ g/m}^2$ ".

If a more precise result is required, carry out another test using new specimens and another test solution and/or another test duration after testing with other test solutions and/or conditions as described in [Clause 16](#).

13.4 Test report

The test report shall include the following information:

- a) all information necessary for the identification of the sample tested;
- b) a reference to [Clause 13](#) of this document, e.g. "Tested in accordance with ISO 28706-2:2017, Clause 13";
- c) the duration of the test: 7 d or 14 d;
- d) the results, giving
 - the loss in mass per unit area as calculated for the time period over which testing was conducted (see [10.1](#)), in grams per square metre, for each individual determination, plus the arithmetic mean, rounded to the nearest 0,1 g/m²,
 - the rate of loss in mass per unit area (see [10.2](#)), in grams per square metre per hour, for each individual determination, plus the arithmetic mean, rounded to the nearest 1×10^{-3} g/(m²·h), and
 - the corrosion rate (see [10.2](#)), in millimetres per year, rounded to the nearest 0,01 millimetres per year;
- e) any deviations from the procedure specified;
- f) any unusual features observed during the test;
- g) the date of the test.

14 Boiling distilled or demineralized water

14.1 General

Carry out this test following the procedure described in [Clause 9](#).

14.2 Test solution

The test solution shall be water ([5.1](#)) with a maximum electrical conductivity between 25 µS/cm and 50 µS/cm. A fresh supply of water is required for each test.

The resistance to chemical corrosion in at least one of the two phases (the liquid phase or the vapour phase) shall be assessed.

14.3 Duration of the test

The heating time, i.e. the time with the condensation rate maintained within the range 8 ml ± 2 ml per 3 min, shall be 48 h (2 d).

If the loss in mass of any of the specimens after this time is less than 8 mg, carry out the test with new specimens and a heating time of 336 h (14 d). If the loss in mass after this time is still less than 8 mg, the result of the test is "<1,6 g/m²".

If a more precise result is required, carry out another test using new specimens and another test solution and/or another test duration after testing with other test solutions and/or conditions as described in [Clause 16](#).

14.4 Test report

The test report shall include the following information:

- a) all information necessary for the identification of the sample tested;
- b) a reference to [Clause 14](#) of this document, e.g. "Tested in accordance with ISO 28706-2:2017, Clause 14" indicating, in addition, whether the resistance to corrosion was assessed in the liquid phase, the vapour phase or both;
- c) the duration of the test: 48 h or 14 d;
- d) the results, giving
 - the loss in mass per unit area for the liquid phase test as calculated for the time period over which testing was conducted (see [10.1](#)), in grams per square metre, for each individual determination, plus the arithmetic mean, rounded to the nearest 0,1 g/m², and
 - the loss in mass per unit area for the vapour phase test as calculated for the time period over which testing was conducted (see [10.1](#)), in grams per square metre, for each individual determination, plus the arithmetic mean, rounded to the nearest 0,1 g/m²;
- e) any deviations from the procedure specified;
- f) any unusual features observed during the test;
- g) the date of the test.

15 Standard detergent solution

15.1 General

Carry out this test following the procedure described in [Clause 9](#).

Deviate from [Clause 9](#) at the end of the required time (2,5 h), remove the hot test solution and fill the cylinder immediately with water ([5.1](#)) at room temperature. Stir the water for 2 min and then remove it. Remove the specimens from the cylinder.

Wipe both sides of the specimens with a soft sponge ([6.2.6](#)) soaked in water ([5.1](#)).

Continue with the procedure as described in [Clause 9](#).

15.2 Test solution

Prepare 0,45 l of a solution containing the following:

- 2,70 g of sodium tripolyphosphate (Na₅P₃O₁₀);
- 0,90 g of anhydrous sodium carbonate (Na₂CO₃);
- 0,27 g of hydrated sodium perborate (NaBO₂·H₂O₂·3H₂O);
- 0,18 g of sodium silicate, containing about 81 % (by mass) of Na₂SiO₃;
- 0,45 g of alkylsulfonate [CH₃(CH₂)_x - C(SO₂Na) H - (CH₂)₃ - CH₃].

The solution shall be made up using water ([5.1](#)) and reagents of analytical grade.

Prepare a fresh test solution for each test.

NOTE Each 2,5 h of test uses 0,45 l of the test solution.

15.3 Test temperature

The test solution shall be heated in the vessel to $95\text{ °C} \pm 2\text{ °C}$ and shall be maintained at that temperature for the duration of the test.

15.4 Duration of the test

The heating time at $95\text{ °C} \pm 2\text{ °C}$ (i.e. without the heating-up time) shall be 2,5 h.

The test shall be carried out at least twice using new specimens and another test solution. The individual values shall not differ from the mean value by more than 20 %.

If a more precise result is required, carry out another test using new specimens and another test solution and/or another test duration after testing with other test solutions and/or conditions as described in [Clause 16](#).

15.5 Test report

The test report shall include the following information:

- a) all information necessary for the identification of the sample tested;
- b) a reference to [Clause 15](#) of this document, e.g. "Tested in accordance with ISO 28706-2:2017, Clause 15";
- c) the duration of the test: 2,5 h;
- d) the results, giving the loss in mass per unit area for the liquid phase test as calculated for the time period over which testing was conducted (see [10.1](#)), in grams per square metre, for each individual determination, plus the arithmetic mean, rounded to the nearest 0,1 g/m²;
- e) any deviations from the procedure specified;
- f) any unusual features observed during the test;
- g) the date of the test.

16 Other test solutions and/or conditions

16.1 General

Carry out this test following the procedure described in [Clause 9](#).

16.2 Test solution

An agreed test solution shall be made up using water ([5.1](#)) and reagents of analytical grade. No test solutions shall be used that could damage the apparatus (e.g. fluorine-containing solutions).

The test report shall indicate whether the resistance to chemical corrosion in both phases was assessed or in only one phase (the liquid phase or the vapour phase).

16.3 Duration of the test

The heating time, i.e. the time with the condensation rate maintained within the range $8\text{ ml} \pm 2\text{ ml}$ per 3 min, shall be included in the test report.

If the loss in mass of any of the specimens after this time is less than 8 mg, the result of the test is "<1,6 g/m²".

If a more precise result is required, carry out another test using new specimens and another test solution and/or another test duration.

16.4 Test report

The test report shall include the following information:

- a) all information necessary for the identification of the sample tested;
- b) a reference to [Clause 16](#) of this document, e.g. "Tested in accordance with ISO 28706-2:2017, Clause 16" indicating, in addition, whether the resistance to corrosion was assessed in the liquid phase, the vapour phase or both;
- c) a description of the test solution;
- d) the duration of the test;
- e) the results, giving, for each phase (liquid/vapour) in which the resistance to corrosion was assessed, the loss in mass per unit area as calculated for the time period over which testing was conducted (see [10.1](#)), in grams per square metre, for each individual determination, plus the arithmetic mean, rounded to the nearest 0,1 g/m², and, if necessary, the rate of loss in mass per unit area and the corrosion rate (see [10.2](#)), also for each individual determination, plus the arithmetic mean, rounded to the nearest 1×10^{-3} g/(m²·h) and 0,01 millimetres per year, respectively;
- f) any deviations from the procedure specified;
- g) any unusual features observed during the test;
- h) the date of the test.

Bibliography

- [1] ISO 1629, *Rubber and latices — Nomenclature*
- [2] ISO 28706-1:2008, *Vitreous and porcelain enamels — Determination of resistance to chemical corrosion — Part 1: Determination of resistance to chemical corrosion by acids at room temperature*
- [3] ISO 28706-3:2008, *Vitreous and porcelain enamels — Determination of resistance to chemical corrosion — Part 3: Determination of resistance to chemical corrosion by alkaline liquids using a hexagonal vessel*
- [4] ISO 28706-4:2016, *Vitreous and porcelain enamels — Determination of resistance to chemical corrosion — Part 4: Determination of resistance to chemical corrosion by alkaline liquids using a cylindrical vessel*
- [5] ISO 28706-5:2010, *Vitreous and porcelain enamels — Determination of resistance to chemical corrosion — Part 5: Determination of resistance to chemical corrosion in closed systems*

British Standards Institution (BSI)

BSI is the national body responsible for preparing British Standards and other standards-related publications, information and services.

BSI is incorporated by Royal Charter. British Standards and other standardization products are published by BSI Standards Limited.

About us

We bring together business, industry, government, consumers, innovators and others to shape their combined experience and expertise into standards-based solutions.

The knowledge embodied in our standards has been carefully assembled in a dependable format and refined through our open consultation process. Organizations of all sizes and across all sectors choose standards to help them achieve their goals.

Information on standards

We can provide you with the knowledge that your organization needs to succeed. Find out more about British Standards by visiting our website at bsigroup.com/standards or contacting our Customer Services team or Knowledge Centre.

Buying standards

You can buy and download PDF versions of BSI publications, including British and adopted European and international standards, through our website at bsigroup.com/shop, where hard copies can also be purchased.

If you need international and foreign standards from other Standards Development Organizations, hard copies can be ordered from our Customer Services team.

Copyright in BSI publications

All the content in BSI publications, including British Standards, is the property of and copyrighted by BSI or some person or entity that owns copyright in the information used (such as the international standardization bodies) and has formally licensed such information to BSI for commercial publication and use.

Save for the provisions below, you may not transfer, share or disseminate any portion of the standard to any other person. You may not adapt, distribute, commercially exploit, or publicly display the standard or any portion thereof in any manner whatsoever without BSI's prior written consent.

Storing and using standards

Standards purchased in soft copy format:

- A British Standard purchased in soft copy format is licensed to a sole named user for personal or internal company use only.
- The standard may be stored on more than 1 device provided that it is accessible by the sole named user only and that only 1 copy is accessed at any one time.
- A single paper copy may be printed for personal or internal company use only.

Standards purchased in hard copy format:

- A British Standard purchased in hard copy format is for personal or internal company use only.
- It may not be further reproduced – in any format – to create an additional copy. This includes scanning of the document.

If you need more than 1 copy of the document, or if you wish to share the document on an internal network, you can save money by choosing a subscription product (see 'Subscriptions').

Reproducing extracts

For permission to reproduce content from BSI publications contact the BSI Copyright & Licensing team.

Subscriptions

Our range of subscription services are designed to make using standards easier for you. For further information on our subscription products go to bsigroup.com/subscriptions.

With **British Standards Online (BSOL)** you'll have instant access to over 55,000 British and adopted European and international standards from your desktop. It's available 24/7 and is refreshed daily so you'll always be up to date.

You can keep in touch with standards developments and receive substantial discounts on the purchase price of standards, both in single copy and subscription format, by becoming a **BSI Subscribing Member**.

PLUS is an updating service exclusive to BSI Subscribing Members. You will automatically receive the latest hard copy of your standards when they're revised or replaced.

To find out more about becoming a BSI Subscribing Member and the benefits of membership, please visit bsigroup.com/shop.

With a **Multi-User Network Licence (MUNL)** you are able to host standards publications on your intranet. Licences can cover as few or as many users as you wish. With updates supplied as soon as they're available, you can be sure your documentation is current. For further information, email subscriptions@bsigroup.com.

Revisions

Our British Standards and other publications are updated by amendment or revision.

We continually improve the quality of our products and services to benefit your business. If you find an inaccuracy or ambiguity within a British Standard or other BSI publication please inform the Knowledge Centre.

Useful Contacts

Customer Services

Tel: +44 345 086 9001

Email (orders): orders@bsigroup.com

Email (enquiries): cservices@bsigroup.com

Subscriptions

Tel: +44 345 086 9001

Email: subscriptions@bsigroup.com

Knowledge Centre

Tel: +44 20 8996 7004

Email: knowledgecentre@bsigroup.com

Copyright & Licensing

Tel: +44 20 8996 7070

Email: copyright@bsigroup.com

BSI Group Headquarters

389 Chiswick High Road London W4 4AL UK