

BS EN ISO 26082-2:2012



BSI Standards Publication

Leather — Physical and mechanical test methods for the determination of soiling

Part 2: Tumbling method (ISO 26082-2:2012)

bsi.

...making excellence a habit.™

National foreword

This British Standard is the UK implementation of EN ISO 26082-2:2012.

The UK participation in its preparation was entrusted to Technical Committee TCI/69, Footwear, leather and coated fabrics.

A list of organizations represented on this committee can be obtained on request to its secretary.

This publication does not purport to include all the necessary provisions of a contract. Users are responsible for its correct application.

© The British Standards Institution 2012. Published by BSI Standards Limited 2012

ISBN 978 0 580 67879 0

ICS 59.140.30

Compliance with a British Standard cannot confer immunity from legal obligations.

This British Standard was published under the authority of the Standards Policy and Strategy Committee on 31 July 2012.

Amendments issued since publication

Date	Text affected
------	---------------

EUROPEAN STANDARD

EN ISO 26082-2

NORME EUROPÉENNE

EUROPÄISCHE NORM

July 2012

ICS 59.140.30

English Version

**Leather - Physical and mechanical test methods for the
determination of soiling - Part 2: Tumbling method (ISO 26082-
2:2012)**

Cuir - Méthodes d'essai physique et mécanique de
détermination de la salissure - Partie 2: Méthode par
culbutage (ISO 26082-2:2012)

Leder - Physikalische und mechanische Prüfungsverfahren
zur Bestimmung des Anschmutzens - Teil 2:
Trommelverfahren (ISO 26082-2:2012)

This European Standard was approved by CEN on 9 June 2012.

CEN members are bound to comply with the CEN/CENELEC Internal Regulations which stipulate the conditions for giving this European Standard the status of a national standard without any alteration. Up-to-date lists and bibliographical references concerning such national standards may be obtained on application to the CEN-CENELEC Management Centre or to any CEN member.

This European Standard exists in three official versions (English, French, German). A version in any other language made by translation under the responsibility of a CEN member into its own language and notified to the CEN-CENELEC Management Centre has the same status as the official versions.

CEN members are the national standards bodies of Austria, Belgium, Bulgaria, Croatia, Cyprus, Czech Republic, Denmark, Estonia, Finland, Former Yugoslav Republic of Macedonia, France, Germany, Greece, Hungary, Iceland, Ireland, Italy, Latvia, Lithuania, Luxembourg, Malta, Netherlands, Norway, Poland, Portugal, Romania, Slovakia, Slovenia, Spain, Sweden, Switzerland, Turkey and United Kingdom.



EUROPEAN COMMITTEE FOR STANDARDIZATION
COMITÉ EUROPÉEN DE NORMALISATION
EUROPÄISCHES KOMITEE FÜR NORMUNG

Management Centre: Avenue Marnix 17, B-1000 Brussels

Foreword

This document (EN ISO 26082-2:2012) has been prepared by Technical Committee CEN/TC 289 "Leather", the secretariat of which is held by UNI, in collaboration with IULTCS "International Union of Leather Technologists and Chemists Societies".

This European Standard shall be given the status of a national standard, either by publication of an identical text or by endorsement, at the latest by January 2013, and conflicting national standards shall be withdrawn at the latest by January 2013.

Attention is drawn to the possibility that some of the elements of this document may be the subject of patent rights. CEN [and/or CENELEC] shall not be held responsible for identifying any or all such patent rights.

According to the CEN/CENELEC Internal Regulations, the national standards organizations of the following countries are bound to implement this European Standard: Austria, Belgium, Bulgaria, Croatia, Cyprus, Czech Republic, Denmark, Estonia, Finland, Former Yugoslav Republic of Macedonia, France, Germany, Greece, Hungary, Iceland, Ireland, Italy, Latvia, Lithuania, Luxembourg, Malta, Netherlands, Norway, Poland, Portugal, Romania, Slovakia, Slovenia, Spain, Sweden, Switzerland and the United Kingdom.

Foreword

ISO (the International Organization for Standardization) is a worldwide federation of national standards bodies (ISO member bodies). The work of preparing International Standards is normally carried out through ISO technical committees. Each member body interested in a subject for which a technical committee has been established has the right to be represented on that committee. International organizations, governmental and non-governmental, in liaison with ISO, also take part in the work. ISO collaborates closely with the International Electrotechnical Commission (IEC) on all matters of electrotechnical standardization.

International Standards are drafted in accordance with the rules given in the ISO/IEC Directives, Part 2.

The main task of technical committees is to prepare International Standards. Draft International Standards adopted by the technical committees are circulated to the member bodies for voting. Publication as an International Standard requires approval by at least 75 % of the member bodies casting a vote.

Attention is drawn to the possibility that some of the elements of this document may be the subject of patent rights. ISO shall not be held responsible for identifying any or all such patent rights.

ISO 26082-2 was prepared by the European Committee for Standardization (CEN) Technical Committee CEN/TC 289, *Leather*, in collaboration with the Physical Tests Commission of the International Union of Leather Technologists and Chemists Societies (IUP Commission, IULTCS) in accordance with the agreement on technical cooperation between ISO and CEN (Vienna Agreement).

IULTCS, originally formed in 1897, is a world-wide organization of professional leather societies to further the advancement of leather science and technology. IULTCS has three Commissions, which are responsible for establishing international methods for sampling and the testing of leather. ISO recognizes IULTCS as an international standardizing body for the preparation of test methods for leather.

ISO 26082 consists of the following parts, under the general title *Leather — Physical and mechanical test methods for the determination of soiling*:

- *Part 1: Rubbing (Martindale) method*
- *Part 2: Tumbling method*

Leather — Physical and mechanical test methods for the determination of soiling —

Part 2: Tumbling method

1 Scope

This part of ISO 26082 specifies a tumbling method which is intended to determine the resistance of all forms of leather to visible soiling through repeated contact with soiled objects. It provides a physical pretreatment routine for leathers that may be vulnerable to loss of soiling resistance in service.

2 Normative references

The following referenced documents are indispensable for the application of this document. For dated references, only the edition cited applies. For undated references, the latest edition of the referenced document (including any amendments) applies.

ISO 105-A02, *Textiles — Tests for colour fastness — Part A02: Grey scale for assessing change in colour*

ISO 105-A03, *Textiles — Tests for colour fastness — Part A03: Grey scale for assessing staining*

ISO 105-A04, *Textiles — Tests for colour fastness — Part A04: Method for the instrumental assessment of the degree of staining of adjacent fabrics*

ISO 105-F09, *Textiles — Tests for colour fastness — Part F09: Specification for cotton rubbing cloth*

ISO 2418, *Leather — Chemical, physical and mechanical and fastness tests — Sampling location*

ISO 2419, *Leather — Physical and mechanical tests — Sample preparation and conditioning*

ISO 12947-1, *Textiles — Determination of the abrasion resistance of fabrics by the Martindale method — Part 1: Martindale abrasion testing apparatus*

3 Principle

A controlled soiling treatment comprising multiple impacts with soiled felt pads is applied to a specimen. This is achieved by tumbling the felt pads within a rotating container into one end of which the specimen is fixed. The change in colour of a standard fabric fixed at the other end of the rotating cylinder is used to determine the end-point of the soiling treatment. A pretreatment to simulate wear may be applied to leathers that are vulnerable to a loss of soiling resistance in service.

4 Reagents

4.1 Synthetic sebum¹⁾, containing (mass fractions):

Free fatty acids	18,0 %
Beef tallow	32,8 %
Fatty acid triglycerides	3,6 %
Lanoline	18,3 %
Cholesterol	3,7 %
Hydrocarbon mixture	12,0 %
Stearate mixture (cutina type)	11,6 %

4.2 Acetone (GPR).

4.3 Butanone (GPR).

4.4 White spirit (CAS No. 64742-48-9) (GPR).

4.5 Colloidal graphite²⁾, having $(18 \pm 0,5)$ % graphite in a water-based dispersion that is miscible with the synthetic sebum solution.

5 Apparatus

Use usual laboratory apparatus and, in particular, the following.

5.1 Suitable tumbling soiling machine³⁾ (see Figure 1), capable of rotating at (24 ± 2) r/min with the facility to change the direction of rotation at 10 min operating intervals, incorporating the following:

- at least four cylinders each of which is
 - of internal length (300 ± 10) mm, and
 - of internal diameter (100 ± 5) mm;
- equipped at each end with a removable lid which maintains the required internal cylinder length and an annular test specimen retaining collar of internal diameter of not less than 75 mm;
- located lengthways in the plane of rotation;

1) A suitable product is: Synthetic Sebum 09 D, available from WFK Testgewebe GmbH, Christenfeld 10, D-41379 Bruggen-Bracht, Germany. This information is given for the convenience of users of this part of ISO 26082 and does not constitute an endorsement by ISO of this product.

2) A suitable product is: Aquadag 18 %, available from Acheson Industries (Europe) Ltd., c/o Postbox 1, 9679 ZG Scheemda, The Netherlands. This information is given for the convenience of users of this part of ISO 26082 and does not constitute an endorsement by ISO of this product.

3) Suitable equipment can be obtained from SATRA Technology Centre, Kettering, UK, NN16 8SD. This information is given for the convenience of users of this International Standard and does not constitute an endorsement by ISO of these products.

- mounted with the centre point of its longitudinal axis at a distance of (240 ± 25) mm from the axis of rotation and its longitudinal axis tangential to this radial line;
- of such dimensions that no point within the cylinders is further than 350 mm from the axis of rotation.

Dimension in millimetres

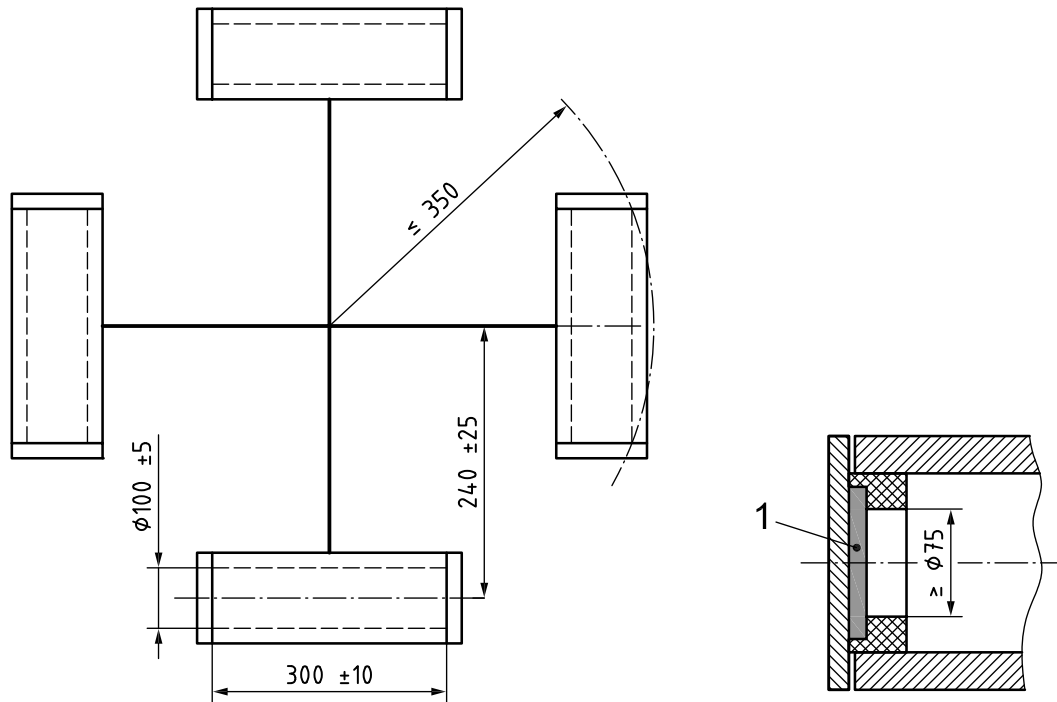

Key

- 1 bleached cotton cloth or leather test specimen, as required

Figure 1 — Schematic (not to scale) diagram of a suitable tumbling soiling machine

5.2 White felt cubes⁴⁾, containing a minimum 90 % wool and of density $0,30 \text{ g/cm}^3$ to $0,40 \text{ g/cm}^3$, with sides measuring $(12,5 \pm 0,5)$ mm. 160 felt cubes are required.

5.3 Oven capable of maintaining a temperature of $(60 \pm 2)^\circ\text{C}$ with local exhaust ventilation and in an ignition risk-free environment.

5.4 Undyed, desized, cotton rubbing cloth, as specified in ISO 105-F09, cut into circles of diameter (96 ± 1) mm. A minimum of six is required.

5.5 Colorimeter, complying with ISO 105-A04 and using CIE 10° observer and illuminant D_{65} . For a sphere-type colorimeter, “spectrally included” shall be used.

5.6 Grey scale, with half step ratings for assessing the degree of staining as described in ISO 105-A03 for white leathers or ISO 105-A02 for other colours.

4) A suitable product can be obtained from Naish Felts Ltd, Wilton, Salisbury SP2 0HD, UK. This information is given for the convenience of users of this part of ISO 26082 and does not constitute an endorsement by ISO of this product.

5.7 Suitable Maeser-type machine, incorporating the following:

5.7.1 Pair or pairs of V-shaped clamps, which are (63 ± 3) mm apart and in the same horizontal plane, into which the test specimen can be clamped. Each clamp shall have a "V" form with an internal angle of $(31 \pm 1)^\circ$ and an internal tip radius of $(7,5 \pm 0,5)$ mm.

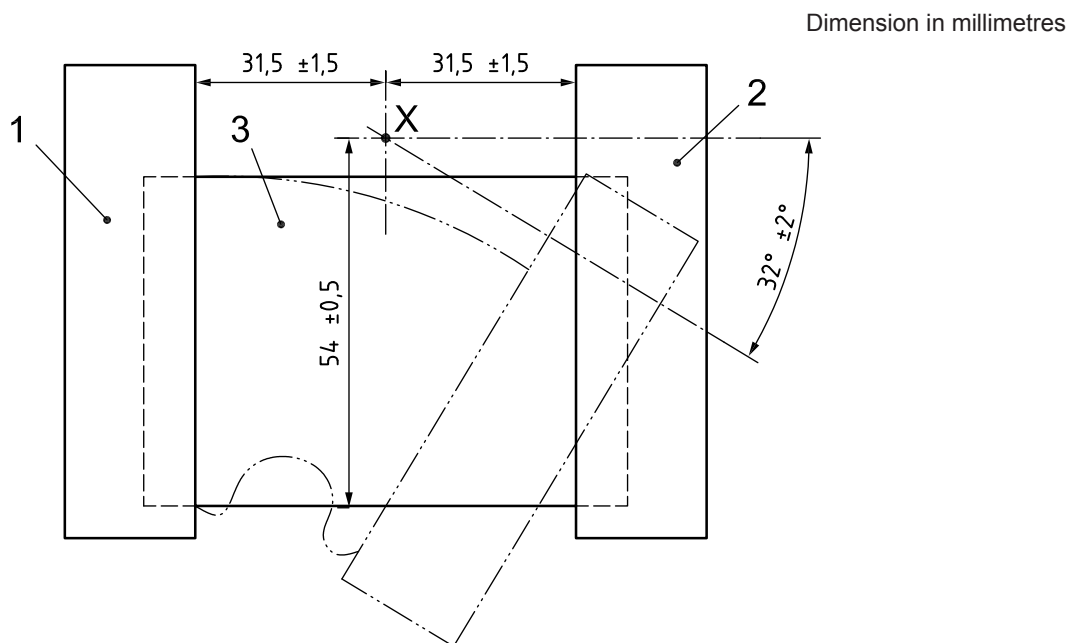

Key

- X pivot point
- 1 stationary clamp (5.7.2)
- 2 moveable clamp (5.7.3)
- 3 test specimen

Figure 2 — Side view of test specimen in "V" shaped clamps

5.7.2 One stationary clamp.

5.7.3 One moveable clamp, which shall pivot about a point X which is midway $(31,5 \pm 1,5)$ mm between the clamps such that the lower end of the clamps move together (see Figure 2).

5.7.4 A pivot point X (see Figure 2), which shall be $(54,0 \pm 0,5)$ mm above the internal face of the clamp at the tip of the "V" and the flexing angle through which the clamp moves shall be $(32 \pm 2)^\circ$.

5.7.5 A method of applying a simple harmonic motion to the moveable clamp (5.7.3) so that it pivots toward the stationary clamp (5.7.2) and back to its original position at a rate of (90 ± 5) cycles/min.

5.7.6 A means of counting the number of cycles of the moveable clamp (5.7.3).

5.8 Martindale abrasion testing apparatus, as described in ISO 12947-1, if required (see 6.4).

5.9 Silicon carbide paper, of grit size 180 and possibly higher, if required (see 6.4).

6 Sampling and sample preparation

6.1 Cut four circular test specimens of diameter (96 ± 1) mm from the leather under test in accordance with ISO 2418 or by ensuring that no specimen is taken from within 50 mm of the edges. If the leather has a grain pattern, select the specimens to be representative of the overall surface texture/appearance.

6.2 Cut four approximately (50×55) mm rectangles of the leather under test following the sampling procedure in 6.1. These are going to be used as reference samples in the assessment (7.4.2).

6.3 Condition the test specimens (6.1 and 6.2) and cotton discs (5.4) in accordance with ISO 2419 and carry out the test in this environment.

6.4 If required, finished or coated leathers that are vulnerable to loss of soiling resistance in service due to deterioration of the surface may be subjected to a physical pretreatment regime prior to testing. The following regime simulates the natural abrasion and flexing that occurs in upholstery leathers in service:

- 100 revolutions with silicon carbide paper of grit size 180, using an abrasion machine complying with that described in ISO 12947-1, with the material under test mounted on the base plate and the abradent paper in the test specimen carrier while applying a nominal contact pressure of 12 kPa;
- followed by 100 000 cycles dry flexing using a machine as described in 5.7.

The abrasion process is intended to be light and superficial, it should not expose the substrate. If excessive abrasion is produced, a less severe abrasive paper with a higher grit size number or reduced contact pressure than specified above should be used and reported according to 8 f).

Unfinished leathers (e.g. aniline, nubuck and suede) are normally only tested in the new condition. If wear simulation is required, a less severe abrasive paper or reduced contact pressure than specified above should be used, or abrasion can be omitted and the sample flexed only. Details of the pretreatment used shall be reported according to 8 f).

7 Procedure

WARNING — When preparing the following soiling solution and soiled cubes, work with local exhaust ventilation in an ignition risk-free environment and wearing chemical resistant gloves and eyewear.

7.1 Preparation of the soiling solution

7.1.1 Weigh out $(145,0 \pm 0,5)$ g of synthetic sebum (4.1) as specified and place into a one-litre beaker and gently warm over water until the sebum liquefies.

7.1.2 Dilute the sebum with approximately 220 ml of acetone (4.2), followed by approximately 220 ml of butanone (4.3) and then by 25,0 ml of white spirit (4.4).

7.1.3 Add $(0,90 \pm 0,01)$ ml of colloidal graphite (4.5) to the diluted sebum solution.

7.1.4 If the solution has solidified, agitate the solution and heat gently over water on a hot plate or water bath, until liquid. **The solution shall be used immediately after preparation and not stored.** This solution is adequate enough to soak 160 felt cubes (5.2). For a greater number of cubes, increase all components of solution proportionally.

7.2 Preparation of the soiled cubes

7.2.1 Immerse a batch of felt cubes (5.2) in the soiling solution (7.1) for approximately 3 min to 5 min to saturate. (A convenient batch size is 20 or 40 cubes.)

- 7.2.2** Remove the felt cubes from the solution using a sieve and allow to drain.
- 7.2.3** Repeat steps 7.2.1 and 7.2.2 until a total of 160 soiled cubes has been obtained.
- 7.2.4** Dry the soiled cubes in a suitable oven (5.3) at (60 ± 2) °C for (3 ± 1) h.
- 7.2.5** Remove the soiled cubes from the oven and allow them to cool to room temperature.
- 7.2.6** Place all 160 soiled cubes in a single cylinder of the soiling machine (5.1) having first ensured that the cylinder has been cleaned using a solvent such as acetone and a clean cloth.
- 7.2.7** Run the machine for a minimum of 16 h to evenly disperse the soiling medium within the felt cubes.
- 7.2.8** Remove the felt cubes from the cylinder and place into an airtight plastic container.

The cubes may be stored in the airtight container for up to 3 months or until the required soiling requirement (7.2.15) cannot be achieved.

7.2.9 Measure the L_R^* , a_R^* and b_R^* values of two circular pieces of the standard cotton fabric (5.4) with the colorimeter (5.5).

7.2.10 Mount the two circular pieces of the fabric in the opposite ends of one of the cylinders of the soiling machine (5.1) having first ensured that the cylinder has been cleaned using a solvent such as acetone and a clean cloth.

7.2.11 Place 40 of the soiled felt cubes (7.2.8) into the cylinder (5.1), fasten the lids in place and run the machine for (90 ± 5) min.

7.2.12 Remove both pieces of standard cotton fabric and immediately measure the L_S^* , a_S^* and b_S^* values of each piece with the colorimeter (5.5).

7.2.13 Calculate the colour difference (ΔE_{CIELAB}) for both pieces of cotton (7.2.12) from their original condition (7.2.9) from the formula:

$$\Delta E_{\text{CIELAB}} = \sqrt{\left[(L_R^* - L_S^*)^2 + (a_R^* - a_S^*)^2 + (b_R^* - b_S^*)^2 \right]}$$

7.2.14 Calculate the mean colour difference for the cotton.

7.2.15 If the mean colour difference (ΔE_{CIELAB}) is less than the lower values of the required range $(20,0 \pm 1,0)$, return the pieces of standard cotton fabric to the cylinder and run the machine for a further (15 ± 2) min.

7.2.16 Repeat steps 7.2.12 to 7.2.15 up to six times until the mean colour difference of the cotton pieces falls in the required range (7.2.15). Note the total tumbling time (t_c) required to achieve the required colour difference.

The cubes shall be discarded and the process repeated with a new batch of felt pads and a suitably adjusted soiling solution if:

- the required colour difference is not achieved after six repeat treatment cycles (7.2.16);
- at any point the required colour difference is exceeded.

7.2.17 Repeat steps 7.2.9 to 7.2.16 until 160 cubes have been prepared.

7.3 Soiling treatment for test specimens

7.3.1 Using the colorimeter (5.5) measure the L_R^* , a_R^* and b_R^* values of sufficient pieces of the standard cotton fabric (5.4) to allow one piece for each cylinder to be used.

7.3.2 Ensure that the inner surface of each cylinder is cleaned using a solvent such as acetone and a clean cloth before the test is conducted.

7.3.3 For each of four cylinders of the soiling machine, mount a test specimen in one lid with the face of the specimen to be tested facing inside the cylinder and a fresh piece of the standard cotton fabric in the other lid. Place 40 soiled felt cubes in each cylinder, attach the lids and run the machine for t_c minutes (as determined in 7.2.16).

7.3.4 Remove the standard cotton pieces from each cylinder and immediately measure the L_S^* , a_S^* and b_S^* values of each piece.

7.3.5 If the colour difference of the cotton fabric is within the required range (7.2.15), proceed to 7.3.7. If the required colour difference has not been achieved, return the cotton piece to the cylinder and run the machine for a further 15 min.

7.3.6 Repeat steps 7.3.4 and 7.3.5 until the required colour difference (7.2.15) of the standard cotton fabric has been achieved.

7.3.7 Once the required colour difference (7.2.15) of the standard cotton fabric has been achieved, remove the test specimen from the corresponding cylinder and carefully remove any visible loose debris from the test face of the specimen by light brushing with a soft bristle brush or similar prior to assessment.

7.4 Assessment of the test specimens

7.4.1 Material that has received no pretreatment

From the centre of each soiled test specimen cut a rectangle measuring (50 × 55) mm, with its longer sides in the same direction as the specimens prepared in 6.2. Mount each rectangle on a card adjacent to a piece of the same dimensions of unsoiled test material. Assess the staining using the appropriate grey scale for staining (5.6).

7.4.2 Material that has been pretreated to simulate wear in service (according to 6.4)

Inspect the surface of the test specimen and note any visible staining, its form and severity (for example, highly visible soiling associated with flex cracks).

From the centre of each soiled test specimen, cut a rectangle measuring approximately (50 × 55) mm, with its longer sides in the same direction as the specimens prepared in 6.1. Mount each rectangle on a card adjacent to a piece of the same dimensions of unsoiled test material (6.2). Assess the staining using the appropriate grey scale for staining (5.6).

8 Test report

The test report shall include the following:

- a) reference to this part of ISO 26082 (ISO 26082-2:2012);
- b) a description of the test specimen(s) including colour;
- c) details of any pretreatment carried out;

- d) details of the soiling solution used;
- e) the grey scale rating, indicating which standard (5.6) was followed, of the staining of each of the test specimens. In the case of specimens that have been pretreated before the soiling procedure, comments regarding the form and severity of the staining as indicated in 7.4.2;
- f) any deviations from this standard test method;
- g) the standard atmosphere used for conditioning and testing as given in ISO 2419;
- h) full details for identification of the sample and any deviation from ISO 2418 with respect to sampling.

British Standards Institution (BSI)

BSI is the national body responsible for preparing British Standards and other standards-related publications, information and services.

BSI is incorporated by Royal Charter. British Standards and other standardization products are published by BSI Standards Limited.

About us

We bring together business, industry, government, consumers, innovators and others to shape their combined experience and expertise into standards-based solutions.

The knowledge embodied in our standards has been carefully assembled in a dependable format and refined through our open consultation process. Organizations of all sizes and across all sectors choose standards to help them achieve their goals.

Information on standards

We can provide you with the knowledge that your organization needs to succeed. Find out more about British Standards by visiting our website at bsigroup.com/standards or contacting our Customer Services team or Knowledge Centre.

Buying standards

You can buy and download PDF versions of BSI publications, including British and adopted European and international standards, through our website at bsigroup.com/shop, where hard copies can also be purchased.

If you need international and foreign standards from other Standards Development Organizations, hard copies can be ordered from our Customer Services team.

Subscriptions

Our range of subscription services are designed to make using standards easier for you. For further information on our subscription products go to bsigroup.com/subscriptions.

With **British Standards Online (BSOL)** you'll have instant access to over 55,000 British and adopted European and international standards from your desktop. It's available 24/7 and is refreshed daily so you'll always be up to date.

You can keep in touch with standards developments and receive substantial discounts on the purchase price of standards, both in single copy and subscription format, by becoming a **BSI Subscribing Member**.

PLUS is an updating service exclusive to BSI Subscribing Members. You will automatically receive the latest hard copy of your standards when they're revised or replaced.

To find out more about becoming a BSI Subscribing Member and the benefits of membership, please visit bsigroup.com/shop.

With a **Multi-User Network Licence (MUNL)** you are able to host standards publications on your intranet. Licences can cover as few or as many users as you wish. With updates supplied as soon as they're available, you can be sure your documentation is current. For further information, email bsmusales@bsigroup.com.

BSI Group Headquarters

389 Chiswick High Road London W4 4AL UK

Revisions

Our British Standards and other publications are updated by amendment or revision.

We continually improve the quality of our products and services to benefit your business. If you find an inaccuracy or ambiguity within a British Standard or other BSI publication please inform the Knowledge Centre.

Copyright

All the data, software and documentation set out in all British Standards and other BSI publications are the property of and copyrighted by BSI, or some person or entity that owns copyright in the information used (such as the international standardization bodies) and has formally licensed such information to BSI for commercial publication and use. Except as permitted under the Copyright, Designs and Patents Act 1988 no extract may be reproduced, stored in a retrieval system or transmitted in any form or by any means – electronic, photocopying, recording or otherwise – without prior written permission from BSI. Details and advice can be obtained from the Copyright & Licensing Department.

Useful Contacts:

Customer Services

Tel: +44 845 086 9001

Email (orders): orders@bsigroup.com

Email (enquiries): cservices@bsigroup.com

Subscriptions

Tel: +44 845 086 9001

Email: subscriptions@bsigroup.com

Knowledge Centre

Tel: +44 20 8996 7004

Email: knowledgecentre@bsigroup.com

Copyright & Licensing

Tel: +44 20 8996 7070

Email: copyright@bsigroup.com



...making excellence a habit.™