

BS EN ISO 25178-606:2015



BSI Standards Publication

Geometrical product specification (GPS) — Surface texture: Areal

Part 606: Nominal characteristics of non-
contact (focus variation) instruments

bsi.

...making excellence a habit.™

National foreword

This British Standard is the UK implementation of EN ISO 25178-606:2015.

The UK participation in its preparation was entrusted to Technical Committee TDW/4, Technical Product Realization.

A list of organizations represented on this committee can be obtained on request to its secretary.

This publication does not purport to include all the necessary provisions of a contract. Users are responsible for its correct application.

© The British Standards Institution 2015.
Published by BSI Standards Limited 2015

ISBN 978 0 580 76436 3

ICS 17.040.20

Compliance with a British Standard cannot confer immunity from legal obligations.

This British Standard was published under the authority of the Standards Policy and Strategy Committee on 30 June 2015.

Amendments/corrigenda issued since publication

Date	Text affected
------	---------------

ICS 17.040.20

English Version

**Geometrical product specification (GPS) - Surface texture: Areal
- Part 606: Nominal characteristics of non-contact (focus
variation) instruments (ISO 25178-606:2015)**

Spécification géométrique des produits (GPS) - État de
surface: Surfacique - Partie 606: Caractéristiques
nominales des instruments sans contact (à variation focale)
(ISO 25178-606:2015)

Geometrische Produktspezifikation (GPS) -
Oberflächenbeschaffenheit: Flächenhaft - Teil 606:
Merkmale von berührungslos messenden Geräten
(Fokusvariation) (ISO 25178-606:2015)

This European Standard was approved by CEN on 21 February 2015.

CEN members are bound to comply with the CEN/CENELEC Internal Regulations which stipulate the conditions for giving this European Standard the status of a national standard without any alteration. Up-to-date lists and bibliographical references concerning such national standards may be obtained on application to the CEN-CENELEC Management Centre or to any CEN member.

This European Standard exists in three official versions (English, French, German). A version in any other language made by translation under the responsibility of a CEN member into its own language and notified to the CEN-CENELEC Management Centre has the same status as the official versions.

CEN members are the national standards bodies of Austria, Belgium, Bulgaria, Croatia, Cyprus, Czech Republic, Denmark, Estonia, Finland, Former Yugoslav Republic of Macedonia, France, Germany, Greece, Hungary, Iceland, Ireland, Italy, Latvia, Lithuania, Luxembourg, Malta, Netherlands, Norway, Poland, Portugal, Romania, Slovakia, Slovenia, Spain, Sweden, Switzerland, Turkey and United Kingdom.



EUROPEAN COMMITTEE FOR STANDARDIZATION
COMITÉ EUROPÉEN DE NORMALISATION
EUROPÄISCHES KOMITEE FÜR NORMUNG

CEN-CENELEC Management Centre: Avenue Marnix 17, B-1000 Brussels

European foreword

This document (EN ISO 25178-606:2015) has been prepared by Technical Committee ISO/TC 213 “Dimensional and geometrical product specifications and verification” in collaboration with Technical Committee CEN/TC 290 “Dimensional and geometrical product specification and verification” the secretariat of which is held by AFNOR

This European Standard shall be given the status of a national standard, either by publication of an identical text or by endorsement, at the latest by December 2015, and conflicting national standards shall be withdrawn at the latest by December 2015.

Attention is drawn to the possibility that some of the elements of this document may be the subject of patent rights. CEN [and/or CENELEC] shall not be held responsible for identifying any or all such patent rights.

According to the CEN-CENELEC Internal Regulations, the national standards organizations of the following countries are bound to implement this European Standard: Austria, Belgium, Bulgaria, Croatia, Cyprus, Czech Republic, Denmark, Estonia, Finland, Former Yugoslav Republic of Macedonia, France, Germany, Greece, Hungary, Iceland, Ireland, Italy, Latvia, Lithuania, Luxembourg, Malta, Netherlands, Norway, Poland, Portugal, Romania, Slovakia, Slovenia, Spain, Sweden, Switzerland, Turkey and the United Kingdom.

Endorsement notice

The text of ISO 25178-606:2015 has been approved by CEN as EN ISO 25178-606:2015 without any modification.

Contents

Page

Foreword	iv
Introduction	vi
1 Scope	1
2 Normative references	1
3 Terms and definitions	1
3.1 Terms and definitions related to all areal surface texture measurement methods.....	2
3.2 Terms and definitions related to <i>x</i> - and <i>y</i> -scanning systems.....	9
3.3 Terms and definitions related to optical systems.....	11
3.4 Terms and definitions related to optical properties of the workpiece.....	13
3.5 Terms and definitions specific to focus variation instruments.....	13
4 Description of the influence quantities	16
4.1 General.....	16
4.2 Overview.....	17
4.3 Influence quantities.....	17
Annex A (informative) Components of a focus variation microscope	19
Annex B (informative) Relation to the GPS matrix model	25
Bibliography	27

Foreword

ISO (the International Organization for Standardization) is a worldwide federation of national standards bodies (ISO member bodies). The work of preparing International Standards is normally carried out through ISO technical committees. Each member body interested in a subject for which a technical committee has been established has the right to be represented on that committee. International organizations, governmental and non-governmental, in liaison with ISO, also take part in the work. ISO collaborates closely with the International Electrotechnical Commission (IEC) on all matters of electrotechnical standardization.

The procedures used to develop this document and those intended for its further maintenance are described in the ISO/IEC Directives, Part 1. In particular the different approval criteria needed for the different types of ISO documents should be noted. This document was drafted in accordance with the editorial rules of the ISO/IEC Directives, Part 2 (see www.iso.org/directives).

Attention is drawn to the possibility that some of the elements of this document may be the subject of patent rights. ISO shall not be held responsible for identifying any or all such patent rights. Details of any patent rights identified during the development of the document will be in the Introduction and/or on the ISO list of patent declarations received (see www.iso.org/patents).

Any trade name used in this document is information given for the convenience of users and does not constitute an endorsement.

For an explanation on the meaning of ISO specific terms and expressions related to conformity assessment, as well as information about ISO's adherence to the WTO principles in the Technical Barriers to Trade (TBT), see the following URL: [Foreword — Supplementary information](#).

The committee responsible for this document is ISO/TC 213, *Dimensional and geometrical product specifications and verification*.

ISO 25178 consists of the following parts, under the general title *Geometrical product specification (GPS) — Surface texture: Areal*:

- *Part 1: Indication des états de surface*
- *Part 2: Terms, definitions and surface texture parameters*
- *Part 3: Specification operators*
- *Part 6: Classification of methods for measuring surface texture*
- *Part 70: Material measures*
- *Part 71: Software measurement standards*
- *Part 72: Format de fichier XML x3p*
- *Part 601: Nominal characteristics of contact (stylus) instruments*
- *Part 602: Nominal characteristics of non-contact (confocal chromatic probe) instruments*
- *Part 603: Nominal characteristics of non-contact (phase-shifting interferometric microscopy) instruments*
- *Part 604: Nominal characteristics of non-contact (coherence scanning interferometry) instruments*
- *Part 605: Nominal characteristics of non-contact (point autofocus probe) instruments*
- *Part 606: Nominal characteristics of non-contact (focus variation) instruments*
- *Part 701: Calibration and measurement standards for contact (stylus) instruments*

The following parts are planned:

- *Part 73: Defects on material measures — Terms and definitions*
- *Part 600: Metrological characteristics for areal-topography measuring methods*
- *Part 607: Nominal characteristics of non-contact (imaging confocal microscopy) instruments*

Introduction

This part of ISO 25178 is a geometrical product specification (GPS) standard and is to be regarded as a general GPS standard (see ISO/TR 14638). It influences the chain link 5 of the chain of standards on areal surface texture.

The ISO/GPS Masterplan given in ISO/TR 14638 gives an overview of the ISO/GPS system of which this part of ISO 25178 is a part of. The fundamental rules of ISO/GPS given in ISO 8015 apply to this part of ISO 25178 and the default decision rules given in ISO 14253-1 apply to specifications made in accordance with this part of ISO 25178, unless otherwise indicated.

For more detailed information of the relation of this part of ISO 25178 to other standards and the GPS matrix model, see [Annex B](#).

This part of ISO 25178 describes the metrological characteristics of focus variation microscopes designed for the measurement of surface topography maps.

For more detailed information on the focus variation technique, see [Annex A](#).

NOTE Portions of this part of ISO 25178, particularly the informative sections, describe patented systems and methods. This information is provided only to assist users in understanding the operating principles of focus variation. This part of ISO 25178 is not intended to establish priority for any intellectual property, nor does it imply a license to proprietary technologies described herein.

Geometrical product specification (GPS) — Surface texture: Areal —

Part 606: Nominal characteristics of non-contact (focus variation) instruments

1 Scope

This part of ISO 25178 defines the metrological characteristics of a particular non-contact method measuring surface texture using a focus variation (FV) sensor.

2 Normative references

The following documents, in whole or in part, are normatively referenced in this document and are indispensable for its application. For dated references, only the edition cited applies. For undated references, the latest edition of the referenced document (including any amendments) applies.

ISO 3274:1996, *Geometrical Product Specifications (GPS) — Surface texture: Profile method — Nominal characteristics of contact (stylus) instruments*

ISO 4287:1997, *Geometrical Product Specifications (GPS) — Surface texture: Profile method — Terms, definitions and surface texture parameters*

ISO 10934-2:2007, *Optics and optical instruments — Vocabulary for microscopy — Part 2: Advanced techniques in light microscopy*

ISO 14978:2006, *Geometrical product specifications (GPS) — General concepts and requirements for GPS measuring equipment*

ISO 17450-1, *Geometrical product specifications (GPS) — General concepts — Part 1: Model for geometrical specification and verification*

ISO 25178-2:2012, *Geometrical product specifications (GPS) — Surface texture: Areal — Part 2: Terms, definitions and surface texture parameters*

ISO 25178-3:2012, *Geometrical product specifications (GPS) — Surface texture: Areal — Part 3: Specification operators*

ISO 25178-6:2010, *Geometrical product specifications (GPS) — Surface texture: Areal — Part 6: Classification of methods for measuring surface texture*

ISO 25178-601, *Geometrical product specifications (GPS) — Surface texture: Areal — Part 601: Nominal characteristics of contact (stylus) instruments*

ISO 25178-602, *Geometrical product specifications (GPS) — Surface texture: Areal — Part 602: Nominal characteristics of non-contact (confocal chromatic probe) instruments*

3 Terms and definitions

For the purposes of this document, the terms and definitions given in ISO 3274, ISO 4287, ISO 10934-2, ISO 17450-1, ISO 14978, ISO 25178-2, ISO 25178-3, ISO 25178-6, ISO 25178-601, ISO 25178-602, and the following apply.

3.1 Terms and definitions related to all areal surface texture measurement methods

3.1.1

areal reference

component of the instrument that generates a reference surface with respect to which the surface topography is measured

3.1.2

coordinate system of the instrument

right hand orthonormal system of axes (x, y, z) defined as:

- (x, y) is the plane established by the *areal reference* (3.1.1) of the instrument (note that there are optical instruments that do not possess a physical areal guide);
- z -axis is mounted parallel to the optical axis and is perpendicular to the (x, y) plane for an optical instrument

Note 1 to entry: See [Figure 1](#).

Note 2 to entry: Normally, the x -axis is the tracing axis and the y -axis is the stepping axis (this note is valid for instruments that scan in the horizontal plane).

Note 3 to entry: See also specification coordinate system [ISO 25178-2:2012, 3.1.2] and measurement coordinate system [ISO 25178-6:2010, 3.1.1].

3.1.3

measurement loop

closed chain which comprises of all the components connecting the workpiece and the probe, e.g. the means of positioning, the work holding fixture, the measuring stand, the drive unit, and the *probing system* (3.5.3)

Note 1 to entry: See [Figure 1](#).

Note 2 to entry: The measurement loop will be subjected to external and internal disturbances that influence the measurement uncertainty.

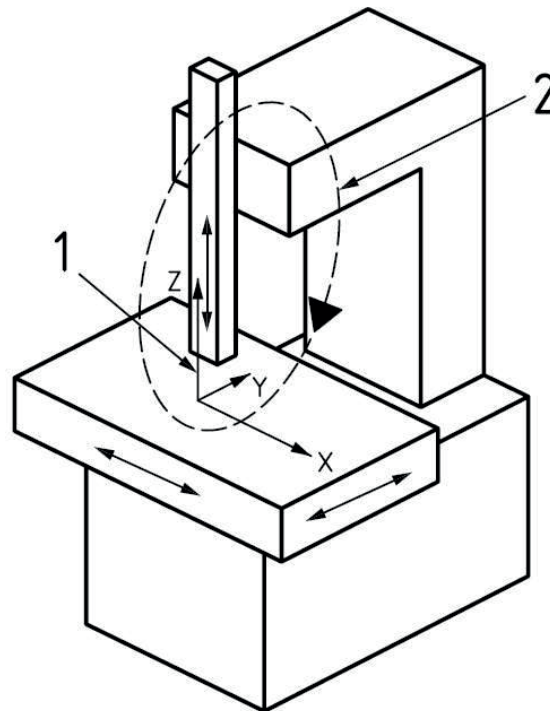

Key

- 1 coordinate system of the instrument
- 2 measurement loop

Figure 1 — Coordinate system and measurement loop of the instrument

3.1.4

real surface of a workpiece

set of features which physically exist and separate the entire workpiece from the surrounding medium

Note 1 to entry: The real surface is a mathematical representation of the surface that is independent of the measurement process.

Note 2 to entry: See also mechanical surface [ISO 25178-2:2012, 3.1.1.1 or ISO 14406:2010, 3.1.1] and electromagnetic surface [ISO 25178-2:2012, 3.1.1.2 or ISO 14406:2010, 3.1.2].

Note 3 to entry: The electromagnetic surface considered for one type of optical instrument can be different from the electromagnetic surface for other types of optical instruments.

[SOURCE: ISO 17450-1:2011]

3.1.5

surface probe

device that converts the surface height into a signal during measurement

Note 1 to entry: In earlier International Standards, this was termed transducer.

3.1.6

measuring volume

range of the instrument stated in terms of the limits on all three coordinates measured by the instrument

Note 1 to entry: For areal surface texture measuring instruments, the measuring volume is defined by the measuring range of the x- and y- drive units and the measuring range of the z-probing system.

[SOURCE: ISO 25178-601:2010, 3.4.1]

3.1.7
response curve

F_x, F_y, F_z

graphical representation of the function that describes the relation between the actual quantity and the measured quantity

Note 1 to entry: See [Figure 2](#).

Note 2 to entry: An actual quantity in x (respectively y or z) corresponds to a measured quantity x_M (respectively y_M or z_M).

Note 3 to entry: The response curve can be used for adjustments and error corrections.

[SOURCE: ISO 25178-601:2010, 3.4.2]

3.1.8
amplification coefficient

$\alpha_x, \alpha_y, \alpha_z$

slope of the linear regression curve obtained from the *response curve* ([3.1.7](#))

Note 1 to entry: See [Figure 3](#).

Note 2 to entry: There will be amplification coefficients applicable to the $x, y,$ and z quantities.

Note 3 to entry: The ideal response is a straight line with a slope equal to 1, which means that the values of the measurand are equal to the values of the input quantities.

Note 4 to entry: See also *sensitivity of a measuring system* (ISO/IEC Guide 99:2007, 4.12).

[SOURCE: ISO 25178-601:2010, 3.4.3, modified — Note 4 to entry has been added.]

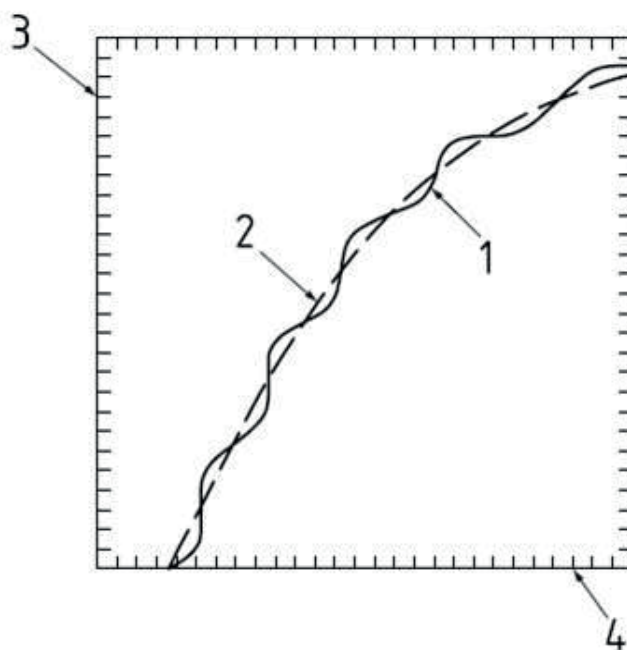

Key

- 1 response curve
- 2 assessment of the linearity deviation by polynomial approximation
- 3 measured quantities
- 4 input quantities

Figure 2 — Example of a non-linear response curve

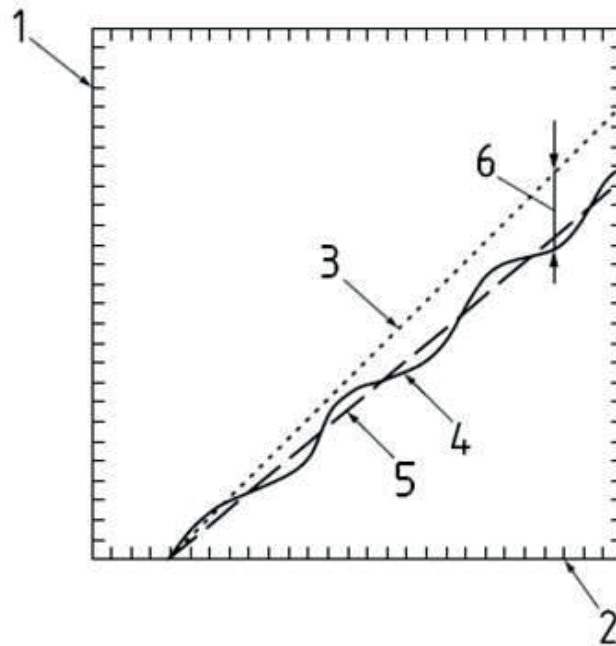

Key

- 1 measured quantities
- 2 input quantities
- 3 ideal response curve
- 4 linearization of the response curve of [Figure 2](#)
- 5 line from which the amplification coefficient α (slope) is derived
- 6 local residual correction error

Figure 3 — Example of the linearization of a response curve

**3.1.9
instrument noise**

N_I

internal noise added to the output signal caused by the instrument, if ideally placed in a noise-free environment

Note 1 to entry: Internal noise can be due to electronic noise, e.g. amplifiers, or to optical noise, e.g. stray light.

Note 2 to entry: This noise typically has high frequencies and it limits the ability of the instrument to detect small scale spatial wavelengths of the surface texture.

Note 3 to entry: The S-filter, according to ISO 25178-3:2012, can reduce this noise.

Note 4 to entry: For some instruments, instrument noise cannot be estimated because the instrument only takes data while moving.

**3.1.10
measurement noise**

N_M

noise added to the output signal occurring during the normal use of the instrument

Note 1 to entry: Notes 2 and 3 of [3.1.9](#) apply as well to this definition.

Note 2 to entry: Measurement noise includes the *instrument noise* ([3.1.9](#)).

3.1.11
surface topography measurement repeatability

repeatability of topography map in successive measurements of the same surface under the same conditions of measurement

Note 1 to entry: Surface topography measurement repeatability provides a measure of the likely agreement between repeated measurements normally expressed as a standard deviation.

Note 2 to entry: See ISO/IEC Guide 99:2007, 2.15, and 2.21 for the general discussion of repeatability and related concepts.

Note 3 to entry: Evaluation of surface topography repeatability is a common method for determining the *measurement noise* (3.1.10).

3.1.12
sampling interval in x (respectively y)

D_x (D_y)

distance between two adjacent measured points along the x -axis (respectively y -axis)

Note 1 to entry: In many microscopy systems, the sampling interval is determined through the optical magnification by the distance between sensor elements in a camera called pixels. For such systems, the terms pixel pitch and pixel spacing are often used interchangeably with the term sampling interval. Another term, pixel width, indicates a length associated with one side (x or y) of the sensitive area of a single pixel and is always smaller than the pixel spacing. Yet another term, sampling zone, may be used to indicate the length or region over which a height sample is determined. This quantity could either be larger or smaller than the sampling interval.

3.1.13
digitisation step in z

D_z

smallest height variation along the z -axis between two ordinates of the extracted surface

3.1.14
lateral resolution

R_l

smallest distance between two features which can be detected

[SOURCE: ISO 25178-601:2010, 3.4.10]

3.1.15
width limit for full height transmission

W_l

width of the narrowest rectangular groove whose measured height remains unchanged by the measurement

[SOURCE: ISO 25178-601:2010, 3.4.11]

Note 1 to entry: Instrument properties such as the sampling interval in x and y , the digitization step in z , and the short wavelength cut-off filter can influence the *lateral resolution* (3.1.14) and the width limit for full height transmission.

Note 2 to entry: When determining this parameter by measurement, the depth of the rectangular groove should be close to that of the surface to be measured.

EXAMPLE 1 Measuring a grid, for which the grooves are wider than the width limit for full height transmission, leads to a correct measurement of the groove depth (see [Figure 4](#) and [Figure 5](#)).

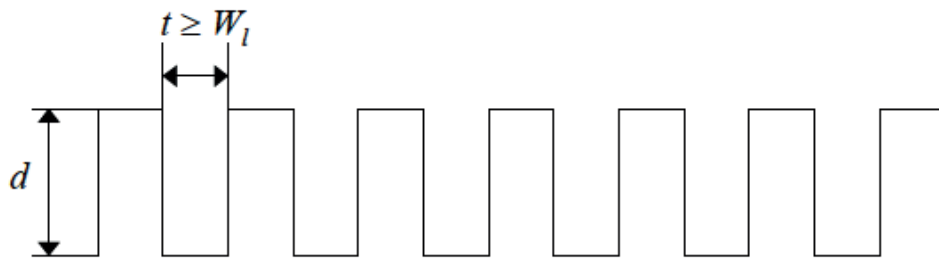

Figure 4 — Grid with horizontal spacing where t is greater than or equal to W_l

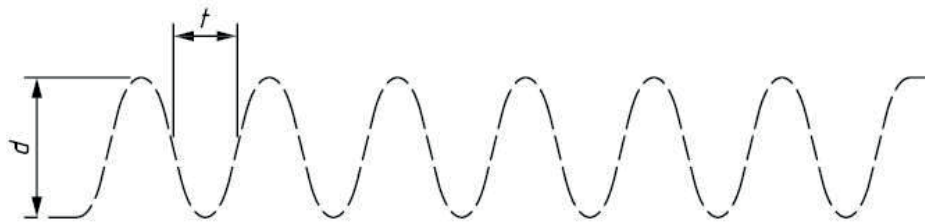

Figure 5 — Measurement of the grid in [Figure 4](#); the spacing and depth of the grid are measured correctly

EXAMPLE 2 Measuring a grid, for which the grooves are narrower than the *width limit for full height transmission* ([3.1.15](#)), leads to an incorrect groove depth (see [Figure 6](#) and [Figure 7](#)). In this situation, the signal is generally disturbed and may contain non-measured points.

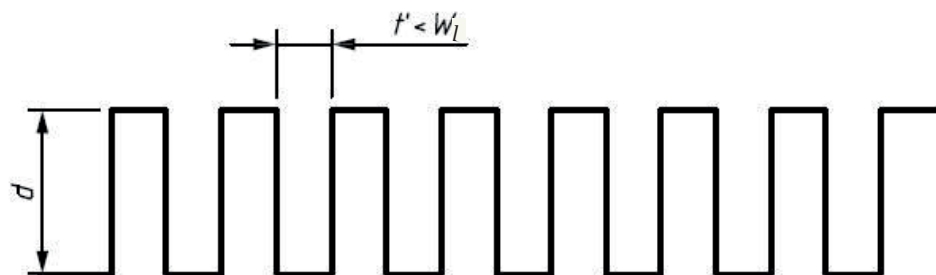

Figure 6 — Grid with horizontal spacing t' smaller than W_l



Figure 7 — Measurement of the grid in [Figure 6](#); the spacing is measured correctly, but the depth is smaller ($d' < d$)

3.1.16

lateral period limit

D_{LIM}

the spatial period of a sinusoidal profile at which the height response of an instrument falls to 50%

Note 1 to entry: The lateral period limit is one metric for describing spatial or lateral resolution of a surface topography measuring instrument and its ability to distinguish and measure closely spaced surface features. Its value depends on the heights of surface features and on the method used to probe the surface. Typical values, mainly for noise suppression, are listed in ISO 25178-3:2012, Table 3, in comparison with the recommended values for short wavelength (s-filters), and sampling intervals.

Note 2 to entry: *Spatial period* is the same concept as *spatial wavelength* and is the *inverse of spatial frequency*.

Note 3 to entry: One factor related to the value of D_{LIM} for optical tools is, e.g. the *Rayleigh criterion* (3.3.7); another is the degree of focus of the objective on the surface.

Note 4 to entry: One factor related to the value of D_{LIM} for contact tools is the stylus tip radius, r_{TIP} (see ISO 25178-601).

Note 5 to entry: Other terms related to *lateral period limit* are *structural resolution* and *topographic spatial resolution*.

3.1.17

maximum local slope

greatest local slope of a surface feature that can be assessed by the probing system

Note 1 to entry: The term “local slope” is defined in ISO 4287:1997, 3.2.9.

3.1.18

instrument transfer function

ITF

f_{ITF}

function of spatial frequency describing how a surface topography measuring instrument responds to an object surface topography having a specific spatial frequency

Note 1 to entry: Ideally, the ITF tells us what the measured amplitude of a sinusoidal grating of a specified spatial frequency ν would be relative to the true amplitude of the grating.

Note 2 to entry: For several types of optical instruments, the ITF may be a non-linear function of height, except for heights much smaller than the optical wavelength.

3.1.19

hysteresis

X_{HYS} , Y_{HYS} , Z_{HYS}

property of measuring equipment or characteristic, whereby the indication of the equipment or value of the characteristic depends on the orientation of the preceding stimuli

Note 1 to entry: Hysteresis can also depend, for example, on the distance travelled after the orientation of stimuli has changed.

Note 2 to entry: For *lateral scanning systems* (3.2.2), the hysteresis is mainly a repositioning error.

[SOURCE: ISO 14978:2006, 3.24]

3.1.20

metrological characteristic (of a measuring instrument)

<measuring equipment> characteristic of measuring equipment which may influence the results of the measurement

Note 1 to entry: Calibration of metrological characteristics may be necessary.

Note 2 to entry: The metrological characteristics have an immediate contribution to measurement uncertainty.

Note 3 to entry: Metrological characteristics for areal surface texture measuring instruments are given in [Table 1](#).

[SOURCE ISO 14978:2006, 3.12]

Table 1 — List of metrological characteristics for surface texture measurement methods

Metrological characteristic	Symbol	Definition	Main potential error along
Amplification coefficient	$\alpha_x, \alpha_y, \alpha_z$	3.1.8 (see Figure 3)	x, y, z
Linearity deviation	l_x, l_y, l_z	Maximum local difference between the line from which the amplification coefficient is derived (see Figure 3 – key 5) and the response curve (see Figure 3 – key 4)	x, y, z
Residual flatness	z_{FLT}	Flatness of the areal reference	z
Measurement noise	N_M	3.1.10	z
Lateral period limit	D_{LIM}	3.1.16	z
Perpendicularity	Δ_{PERxy}	Deviation from 90° of the angle between the x - and y -axes	x, y

3.2 Terms and definitions related to x - and y -scanning systems

3.2.1

areal reference guide

component(s) of the instrument that generate(s) the reference surface in which the probing system moves relative to the surface being measured according to a theoretically exact trajectory

Note 1 to entry: In the case of x - and y -scanning areal surface texture measuring instruments, the areal reference guide establishes a reference surface [ISO 25178-2:2012, 3.1.8]. It can be achieved through the use of two linear and perpendicular reference guides [ISO 3274:1996, 3.3.2] or one areal reference surface guide.

3.2.2

lateral scanning system

system that performs the scanning of the surface to be measured in the (x, y) plane

Note 1 to entry: There are essentially four aspects to a surface texture scanning instrument system; the x -axis drive, the y -axis drive, the z -measurement probe, and the surface to be measured. There are different ways in which these may be configured, and thus, there will be a difference between different configurations as explained in [Table 2](#).

Table 2 — Possible different configurations for reference guides (x and y)

		Drive unit				
		Two reference guides (x and y)			One areal reference guide	
		Px o Cy ^a	Px o Py	Cx o Cy	Pxy	Cxy
Probing system	A: without arcuate error correction	Px o Cy-A	Px o Py-A	Cx o Cy-A	Pxy-A	Cxy-A
	S: without arcuate error or with arcuate error corrected	Px o Cy-S	Px o Py-S	Cx o Cy-S	Pxy-S	Cxy-S

NOTE For two given functions, f and g, f o g is the combination of these functions.

^a Px = probing system moving along the x-axis
 Py = probing system moving along the y-axis
 Cx = component moving along the x-axis
 Cy = component moving along the y-axis

Note 2 to entry: When a measurement consists of a single field of view of a microscope, x- and y-scanning is not used. However, when several fields of view are linked together by stitching methods (see ISO 25178-601), the system is considered to be a scanning system.

3.2.3 drive unit x (respectively y)

component of the instrument that moves the probing system or the surface being measured along the reference guide on the x-axis (respectively y-axis) and returns the horizontal position of the measured point in terms of the lateral x-coordinate (respectively y-coordinate) of the profile

3.2.4 lateral position sensor

component of the drive unit that provides the lateral position of the measured point

Note 1 to entry: The lateral position can be measured or inferred by using, for example, a linear encoder, a laser interferometer, or a counting device coupled with a micrometer screw.

3.2.5 speed of measurement

v_x
 speed of the probing system relative to the surface to be measured during the measurement along the x-axis

[SOURCE: ISO 25178-601:2010, 3.4.13]

3.2.6 static noise

N_S
 combination of the *instrument* and *environmental noise* on the output signal when the instrument is not scanning laterally

Note 1 to entry: *Environmental noise* is caused by, e.g. seismic, sonic, and external electromagnetic disturbances.

Note 2 to entry: Notes 2 and 3 in 3.1.9 apply to this definition.

Note 3 to entry: Static noise is included in *measurement noise* (3.1.10).

3.2.7

dynamic noise

N_D

noise occurring during the motion of the drive units on the output signal

Note 1 to entry: Notes 2 and 3 in [3.1.9](#) apply to this definition.

Note 2 to entry: Dynamic noise includes the *static noise* ([3.2.6](#)).

Note 3 to entry: Dynamic noise is included in *measurement noise* ([3.1.10](#)).

3.3 Terms and definitions related to optical systems

3.3.1

light source

optical device emitting an appropriate range of wavelengths in a specified spectral region

3.3.2

measurement optical bandwidth

$B_{\lambda 0}$

range of wavelengths of light used to measure a surface

Note 1 to entry: Instruments may be constructed with light sources with a limited optical bandwidth and/or with additional filter elements to further limit the optical bandwidth.

3.3.3

measurement optical wavelength

λ_0

effective value of the wavelength of the light used to measure a surface

Note 1 to entry: The measurement optical wavelength is affected by conditions such as the light source spectrum, spectral transmission of the optical components, and spectral response of the image sensor array.

3.3.4

angular aperture

angle of the cone of light entering an optical system from a point on the surface being measured

[SOURCE: ISO 25178-602:2010, 3.3.3]

3.3.5

half aperture angle

α

one half of the *angular aperture* ([3.3.4](#))

Note 1 to entry: This angle (see [Figure 8](#)) is sometimes also called as half cone angle.

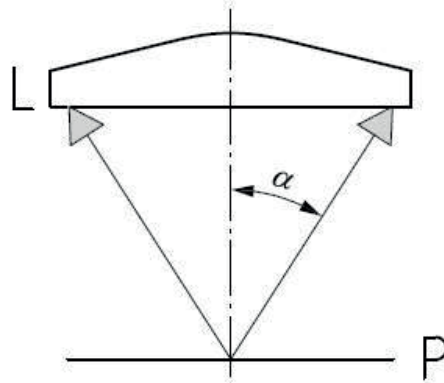

Key

- L lens or optical system
- P focal point
- α half aperture angle

Figure 8 — Half aperture angle

**3.3.6
numerical aperture**

A_N
sine of the *half aperture angle* (3.3.5) multiplied by the refractive index n of the surrounding medium

Note 1 to entry: $A_N = n \sin \alpha$

Note 2 to entry: In air for visible light, $n \cong 1$.

Note 3 to entry: The numerical aperture is dependent on the wavelength of light. Typically, the numerical aperture is specified for the wavelength that is in the middle of the *measurement optical bandwidth* (3.3.2).

**3.3.7
Rayleigh criterion**

quantity characterizing the spatial resolution of an optical system given by the separation of two-point sources at which the first diffraction minimum of the image of one point source coincides with the maximum of the other

Note 1 to entry: For a theoretically perfect, incoherent optical system with a filled objective pupil, the Rayleigh criterion of the optical system is equal to $0,61 \lambda_0/A_N$.

Note 2 to entry: This parameter is useful for characterizing the instrument response to features with heights much less than λ_0 .

**3.3.8
Sparrow criterion**

quantity characterizing the spatial resolution of an optical system given by the separation of two point sources at which the second derivative of the intensity distribution vanishes between the two-imaged points

Note 1 to entry: For a theoretically perfect incoherent optical system with a filled objective pupil, the Sparrow criterion of the optical system is equal to $0,47 \lambda_0/A_N$, approximately 0,77 times the *Rayleigh criterion* (3.3.7).

Note 2 to entry: This parameter is useful for characterizing the instrument response to features with heights much less than λ_0 .

Note 3 to entry: Under the same measurement conditions as the notes above, the Sparrow criterion is nearly equal to the spatial period of $0,5 \lambda_0/A_N$, for which the theoretical instrument response falls to zero.

3.4 Terms and definitions related to optical properties of the workpiece

3.4.1

surface film

material deposited onto another surface whose optical properties are different from that surface

Note 1 to entry: This concept may also be called *surface layer*.

3.4.2

thin film

film whose thickness is such that the top and bottom surfaces cannot be readily separated by the optical measuring system

Note 1 to entry: For some measurement systems with special properties and algorithms, the thicknesses of thin films may be derived.

3.4.3

thick film

film whose thickness is such that the top and bottom surfaces can be readily separated by the optical measuring system

3.4.4

optically smooth surface

surface from which the reflected light is primarily specular and scattered light is not significant

Note 1 to entry: An optically smooth surface behaves locally like a mirror.

Note 2 to entry: A surface that acts as optically smooth under certain conditions such as wavelength range, *numerical aperture* (3.3.6), pixel resolution, etc. can act as optically rough when one or more of these conditions change.

3.4.5

optically rough surface

surface that does not behave as an *optically smooth surface* (3.4.4), i.e. where scattered light is significant

Note 1 to entry: A surface that acts as optically rough under certain conditions such as wavelength range, numerical aperture, pixel resolution, etc. can act as optically smooth when one or more of these conditions change.

3.4.6

optically non-uniform material

sample with different optical properties in different regions

Note 1 to entry: An optically non-uniform material may result in measured phase differences across the field of view that can be erroneously interpreted as differences in surface height.

3.5 Terms and definitions specific to focus variation instruments

3.5.1

focus variation microscopy

FV

surface topography measurement method whereby the sharpness of the surface image (or another property of the reflected light at optimum focus) in an optical microscope is used to determine the surface height at each position along the surface

[SOURCE: ISO 25178-6:2010, 3.3.9]

3.5.2

focus variation sensor

device that converts the height of points on the surface into signals during measurement using the focus variation method

3.5.3 probing system

<surface texture, *focus variation sensor* (3.5.2)> components of a focus variation instrument consisting of optical components, a vertical scanner, a digital optical sensor, an illumination system, and an optoelectronic controller

3.5.4 focus variation measurement algorithm

algorithm for analyzing the variation of focus in order to calculate the scan positions where each point is best in focus

3.5.5 focus information

measure to quantify the degree of focus at a specific lateral position in the surface image and at a specific vertical scan position

3.5.6 focus information curve

one-dimensional function where the *x*-axis contains the different vertical scan positions and the *y*-axis contains the corresponding *focus information* (3.5.5) at a specific lateral position in the surface image

3.5.7 light source

<focus variation sensor> source of light containing a continuum of wavelengths in a predefined spectral and spatial range

Note 1 to entry: Possible light sources are coaxial illumination, ring light, and external light sources.

3.5.8 angular range of illumination

α
angular range from which the specimen is illuminated

3.5.8.1 angular range of coaxial illumination

α_1
angular range from which the specimen is coaxially illuminated

Note 1 to entry: The value α_1 can be influenced by the choice of the objective.

Note 2 to entry: The value α_1 is often related to the angular range of detection (see [Figure 10](#)).

Note 3 to entry: In ordinary cases, the value α_1 can be derived from the numerical aperture of the objective.

Note 4 to entry: When special illumination sources are used (ring light, external light source, etc., see [Figure 9](#)), the *angular range of illumination* (3.5.8) can be much larger than α_1 .

3.5.8.2 minimum incident angle of ring light illumination

β_{Imin}
minimum incident angle of ring light illumination from which the specimen is illuminated

3.5.8.3 maximum incident angle of ring light illumination

β_{Imax}
maximum incident angle of ring light illumination from which the specimen is illuminated

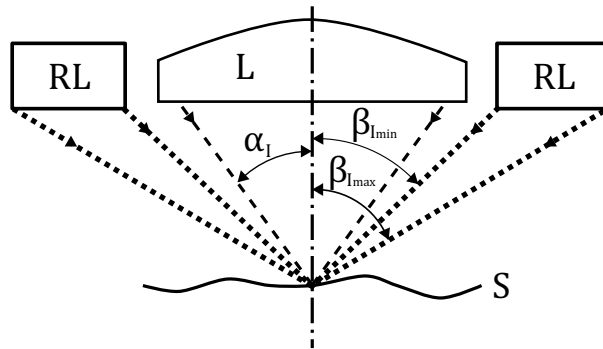

Key

- L lens of optical system
- RL ring light
- α_l angular range of coaxial illumination
- β_{lmin} minimum incident angle of ring light illumination
- β_{lmax} maximum incident angle of ring light illumination
- S specimen

Figure 9 — Angular range of illumination

3.5.9

angular range of detection

α_D

angular range of light rays that can be gathered by the objective (see [Figure 10](#))

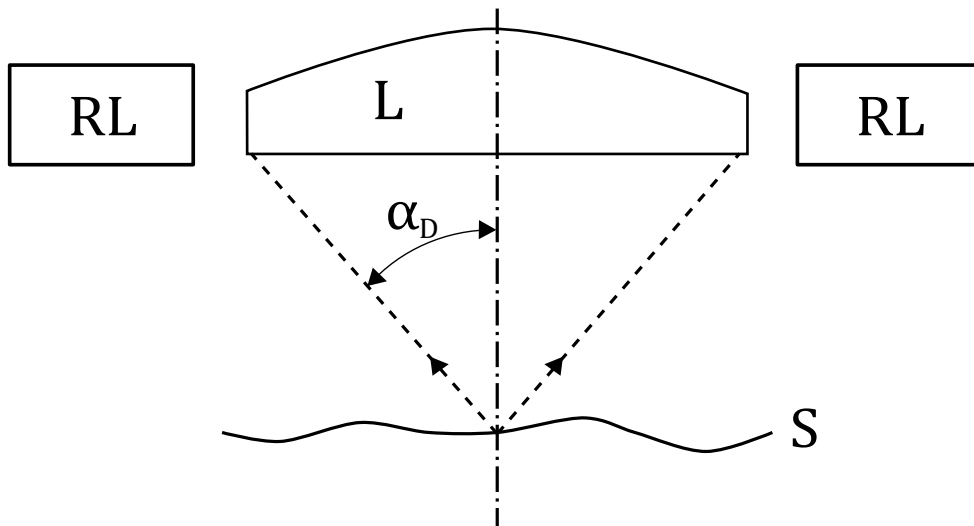

Key

- L lens of optical system
- RL ring light
- α_D angular range of detection
- S specimen

Figure 10 — Angular range of detection

3.5.10

scan height

total range of physical path length traversed by the FV scan

Note 1 to entry: The scan height is usually synonymous with the total displacement of the FV sensor mechanically translated along its optical axis during data acquisition.

3.5.11

polarization

method which allows one to filter out light waves in certain polarization states by using special optical elements called *polarizers* ([3.5.13](#)) or analyzers

3.5.12

analyzer

optical element used to polarize the rays of the light after they have been reflected from the specimen and gathered by the objective

3.5.13

polarizer

optical element used to polarize the rays of the *light source* ([3.5.7](#)) before they are transmitted to the specimen

3.5.14

polarization angle

angle between the *polarization direction* ([3.5.15](#)) of the analyzer and the polarizer

3.5.15

polarization direction

direction of the electric vector the light waves that are transmitted by a polarizing optical element

3.5.16

sensor settings

settings that influence how the sensor converts the light information into a digital signal

Note 1 to entry: Typical settings are *exposure time* ([3.5.18](#)) and *gamma* ([3.5.17](#)).

3.5.17

gamma

sensor setting that performs a non-linear transformation of the sensor response in relation to exposure using an exponential function

3.5.18

exposure time

amount of [time](#) during which a photo[sensitive material](#) is acted upon by [light](#)

3.5.19

roughness threshold

minimum S_q value of a workpiece at a certain short wavelength cut-off spatial frequency needed for proper measurements

4 Description of the influence quantities

4.1 General

Focus variation instruments provide a measurement of lateral (x and y) and height (z) values from which the surface texture parameters are calculated.

4.2 Overview

Focus variation instruments use the following measurement process:

- To perform a complete measurement of the surface, the optics is moved vertically along the optical axis while continuously capturing data from the surface. This means that each region of the object is sharply focused. Algorithms convert the acquired sensor data into 3D information and a true colour image with full-depth of field. The 3D information is then calculated by analysing the focus information (curve) along the vertical axis. (see [Annex A](#)).

4.3 Influence quantities

Influence quantities for focus variation instruments are given in [Table 3](#). The table indicates the metrological characteristics (see [3.1.20, Table 1](#)) that are affected by deviations of influence quantities.

Table 3 — Influence quantities for focus variation instruments

Component	Element	Influence quantities		Metrological characteristic affected
Light source		λ_0	Measurement optical wavelength	$l_z, N_M, D_{LIM}, z_{FLT}$
		B_{λ_0}	Measurement optical bandwidth	$l_z, N_M, D_{LIM}, z_{FLT}$
		$\alpha_l, \beta_{lmin}, \beta_{lmax}$	Angular range of illumination	$l_z, N_M, D_{LIM}, z_{FLT}$
		S, P, C, U	The state of polarization of the light impinging on the measured surface. The polarization is typically described as S, P, circular, or unpolarized.	$l_z, N_M, D_{LIM}, z_{FLT}$
Microscope imaging system		A_N	Numerical aperture	$l_z, N_M, D_{LIM}, z_{FLT}$
		M_{IMG}	Magnification between object sizes on the surface and image sizes on the sensor	α_x, α_y
		Q_{OPT}	General quality of the optical components used including aberrations, transmission, alignment errors, etc.	$\alpha_x, \alpha_y, \alpha_z, z_{FLT}, l_x, l_y, l_z, D_{LIM}, \Delta_{PER}$
		F_{PSF}	Point spread function of the microscope imaging system (see ISO 10934-2:2007, 2.35)	$\alpha_x, \alpha_y, \alpha_z, z_{FLT}, l_x, l_y, l_z, D_{LIM}$
		P_{DISXY}	Lateral distortion of the magnified image on the camera	$\alpha_x, \alpha_y, l_x, l_y, \Delta_{PER}$
Vertical scanning system		F_z	Response curve of the vertical scanning system	α_z, l_z, z_{FLT}
Camera		Δ_x	x-pixel spacing	D_{LIM}
		Δ_y	y-pixel spacing	D_{LIM}
Controller	Acquisition software	Δ_z	Z-scan increment	N_M
		A_{ACQ}	Acquisition method – Manner in which the sensor data are acquired (e.g. continuously, discretely stepped)	l_z, N_M
		A_{NUM}	Measurement algorithm – Number of images acquired	l_z, N_M, z_{FLT}
	Focus variation algorithm	A_{FOV}	Procedure that constructs the surface heights from the acquired data using the focus variation method	$\alpha_x, \alpha_y, \alpha_z, l_x, l_y, l_z, D_{LIM}, N_M$
		A_{CORR}	Method to correct optical and stage aberrations	$\alpha_x, \alpha_y, \alpha_z, z_{FLT}, l_x, l_y, l_z, D_{LIM}, \Delta_{PER}$
		R_l	Lateral resolution	$l_x, l_y, l_z, D_{LIM}, N_M$

Table 3 (continued)

Component	Element	Influence quantities		Metrological characteristic affected
Instrument overall	D_x or D_y	Lateral sampling interval equal to the lateral pixel spacing of the camera divided by the magnification M_{IMG}		D_{LIM}
	N_I	Instrument noise		N_M
	N_{VIB}	Environmental Vibration – Unwanted motion between the surface being measured and the optical system		N_M
	T_I	Integration time required to complete a single scan in Z		N_M

Annex A (informative)

Components of a focus variation microscope

A.1 Typical configuration

Figure A.1 illustrates the typical configuration of a focus variation microscope.

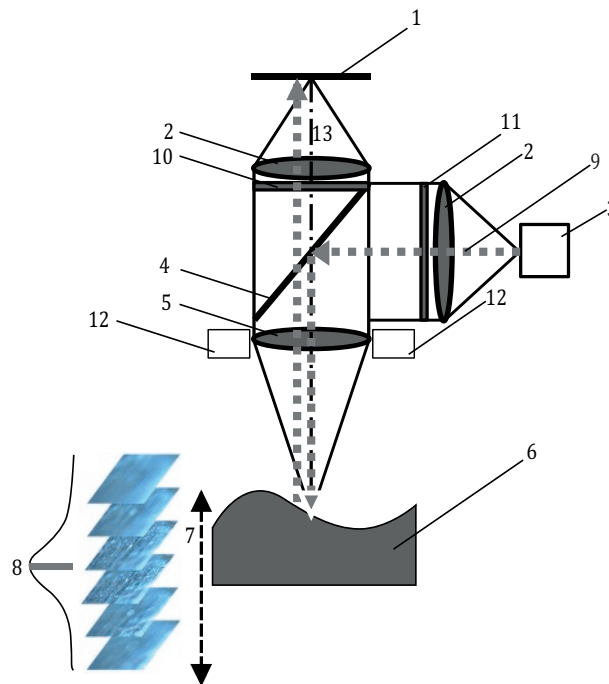

Key

- 1 array detector
- 2 optical components
- 3 white light source
- 4 illumination beam splitter
- 5 objective
- 6 specimen
- 7 vertical scan
- 8 focus information curve with maximum position
- 9 light beam (...)
- 10 analyzer
- 11 polarizer
- 12 ring light
- 13 optical axis (-.-.)

Figure A.1 — Schematic diagram of a typical measurement device based on focus variation

A.2 Operation principle

Focus variation^[7] combines the small-depth of focus of an optical system with vertical scanning to provide topographical information from the variation of focus. In the following, the operating principle is demonstrated for a typical focus variation microscope schematically shown in [Figure A.1](#). The main component of the system is the optical microscope containing various lenses that can be equipped with different objectives allowing measurements with different resolution. With a beam splitting mirror, light emerging from a white light source is inserted into the optical path of the system and focused onto the specimen through the objective. Depending on the topography of the specimen, the light is scattered into several directions as soon as it hits the specimen through the objective. If the topography shows diffuse reflective properties, the light is scattered strongly into all directions. In the case of specular reflection, the light is reflected mainly into one direction. All rays emerging from the specimen and hitting the objective lens are collected in the optics and gathered by a light sensitive sensor behind the beam splitting mirror. Due to the small depth of field of the optics, only small regions of the object are sharply imaged. To perform a complete detection of the surface with full depth of field, the optics is moved vertically along the optical axis while continuously capturing data from the surface. Each region of the object is sharply focused at one of the vertical positions of the scanner. Algorithms convert the acquired sensor data into 3D information and a true colour image with full-depth of the field. This is achieved by analysing the variation of focus along the vertical axis.

In addition to the scanned height data, the microscope also delivers colour information for each measured 3D point. This provides an optical colour image which eases measurements and identification of distinctive local surface features. The visual correlation between the optical colour image of the specimen surface and its depth information are often linked to each other and are, therefore, an essential aspect of meaningful 3D measurement.

For the description of the focus variation technique, see Reference [\[10\]](#). The focus variation technique is sometimes also referred to as shape from focus (see Reference [\[11\]](#)).

A.3 Light source

In contrast to other optical techniques that are limited to coaxial illumination, the maximum local slope is not limited by the numerical aperture of the objective. Focus variation can be used with a large range of different illumination sources (such as a ring light) which allows the measurement of local slope angles up to 90°. Additionally, the light can be polarized using polarization filters (polarizer and analyser) which allow the removal of specular light components. This is especially helpful for the measurement of metallic surfaces containing steep and flat surface elements.

A.4 Scanner

There are various methods for performing the vertical scan. These are moving the sample, moving the whole optics, and moving parts of the optics.

A.5 Objectives

The objectives that are used for focus-variation should meet some basic requirements. They should have long working distances in order to allow the measurement of high and rough specimens. The numerical aperture should be as large as possible since the numerical aperture directly influences the depth of field which is the basic parameter for measurements based on focus-variation. Since the measurement is performed by white light, the objectives should be corrected for freedom of chromatic aberrations.

A.6 Algorithm

Various methods exist to analyse the variation of focus usually based on the calculation of image sharpness at each scan position. Typically, such focus information is derived by evaluating the values of the surface image in a small local area. In general, an object point is focused more sharply when neighbouring points

have a larger variation of image intensity. As an example, the standard deviation of these values can be used as a simple measure for the focus information. This is demonstrated in [Table A.1](#), where focus information is calculated for a chess-pattern like object at five different scan positions.

The focus information curve consists of the focus information for each vertical scan position. By calculating the maximum of the focus information curve, the height information can be determined for one object point. Various methods exist to calculate the maximum of the focus curve. Three of them are summarized in [Table A.2](#) together with their speed and accuracy. The fastest, but least accurate method, is to simply use the scan position with the maximum focus information. More advanced methods fit polynomials or more complex functions with the focus information curve and calculate the maximum as the peak of the fitted polynomial or function.

Table A.1 — Calculation of focus information using the standard deviation of the surface image within a 5×5 neighbourhood of points around the point of interest

Scan position	Surface image	Standard deviation
Out of focus		10
Almost in focus		20
In focus		50
Almost in focus		20
Out of focus		10
<p>1 Point of interest for which the focus information is calculated. 2 5×5 neighbourhood of points used to calculate the focus information (standard deviation).</p>		

Table A.2 — Methods for calculating the peak of the focus information curve

Method	Accuracy	Speed
Polynomial	Good	Medium
Curve fitting	Accurate	Slow
Peak	Not very accurate	Fast

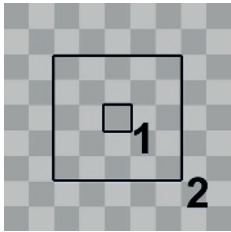
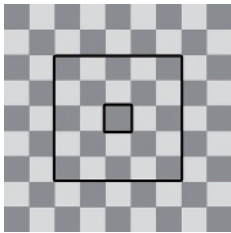
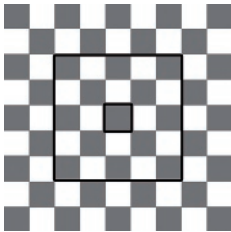
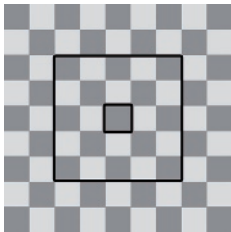
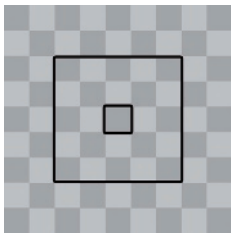
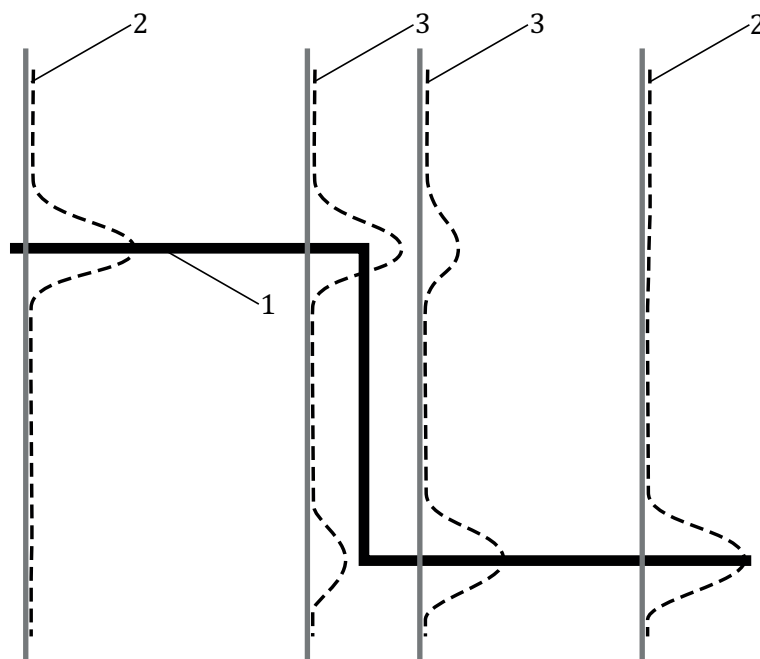

Key

- 1 specimen consisting of a step height
- 2 focus information curves with single peak
- 3 focus information curves with two peaks

Figure A.2 — Step height with corresponding focus information curves at four positions

A characteristic of the focus variation technology is that step heights can be measured without smoothing effects where the peak regions corresponding to the different heights do not overlap. This is demonstrated in [Figure A.2](#), which shows a step height feature with schematic focus information curves at four different positions. The two focus information curves next to the step discontinuity show two peaks. The algorithm can determine the largest peak and therefore, the correct height of the feature at each position. This is only violated for very small step heights where the focus information peaks overlap so that their maxima cannot be distinguished.

A.7 Vibrations

Since the measurement data are acquired over a period of time, atmospheric and mechanical vibrations can have an influence on the measurement results. Due to the measurement principle, however, which uses the whole focus information curve for the height measurement, the measurement is rather robust with respect to smaller or sporadic occurring vibrations.

A.8 Limitations

Since the described technique relies on analysing the variation of focus, it is only applicable to surfaces where the surface image varies sufficiently during the vertical scanning process. Surfaces not fulfilling

these requirements, such as transparent specimens or components with only a small local roughness, have focus curves without dominant peaks. As a result, the position with maximum focus cannot be detected unambiguously. Typically, focus variation delivers repeatable measurement results for surfaces with a local S_a as small as 5 nm to 15 nm. The filtering cut-off frequency for this S_a calculation lies between $1\mu\text{m}$ and $3\mu\text{m}$, depending on the sampling distance. As far as lateral resolution values are concerned, focus variation has the same limitations as other optical microscopy techniques.

A.9 Applications

Focus variation is used to perform 3D surface measurement for industrial quality assurance, as well as research and development activities. Key applications are surface analysis and characterization in, e.g. the cutting tool industry, precision manufacturing, the automotive industry, all kinds of materials science, corrosion and tribology, electronics, medical device development, or the paper and print industry.^[7] The focus variation technique is used for form^[9] and roughness measurements.^[8] A typical measurement example is provided in [Figure A.3](#) which shows a 3D measurement by FV of an angular gear with true and pseudo colour information.

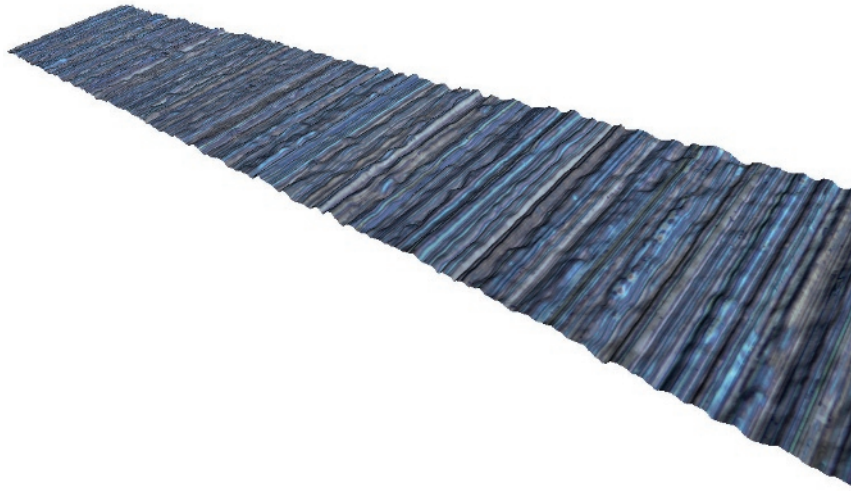

a) with true colour information

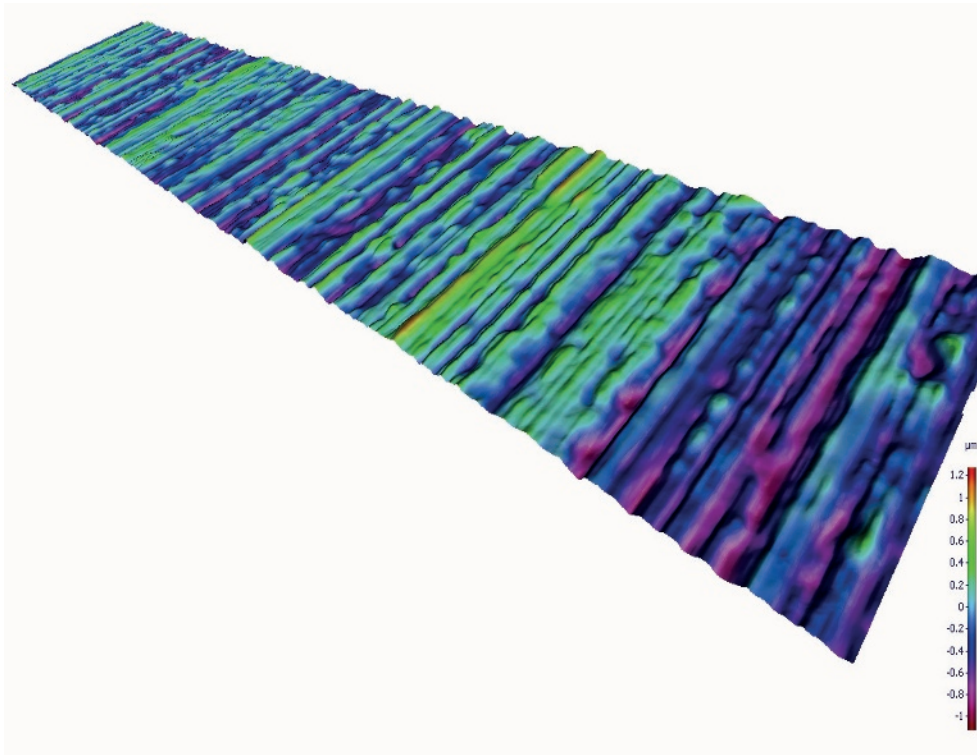

b) pseudo colour information

Figure A.3 — 3D topography measurement by FV of an angular gear

Annex B (informative)

Relation to the GPS matrix model

B.1 General

For full details about the GPS matrix model, see ISO/TR 14638.

B.2 Information of this part of ISO 25178 and its use

This part of ISO 25178 defines the basic terminology and metrological characteristics for focus variation instruments.

B.3 Position in the GPS matrix model

This part of ISO 25178 is a general GPS standard which influences the chain link 5 of the chains of standards on areal surface texture in the general GPS matrix as illustrated in [Table B.1](#).

Table B.1 — Position in the GPS matrix model

Global GPS standards							
Fundamental GPS standards	General GPS matrix						
	Chain link number	1	2	3	4	5	6
	Size						
	Distance						
	Radius						
	Angle						
	Form of line independent of datum						
	Form of line dependent on datum						
	Form of surface independent of datum						
	Form of surface dependent on datum						
	Orientation						
	Location						
	Circular run-out						
	Total run-out						
	Datums						
	Roughness profile					X	
	Waviness profile					X	
	Primary profile					X	
	Surface imperfections						
	Edges						
	Areal surface texture					X	

B.4 Related International Standards

The related International Standards are those of the chains of standards indicated in [Table B.1](#).

Bibliography

General

- [1] ISO/IEC Guide 99:2007, *International vocabulary of metrology — Basic and general concepts and associated terms (VIM)*
- [2] ISO 8015, *Geometrical product specifications (GPS) — Fundamentals — Concepts, principles and rules*
- [3] ISO 14253-1, *Geometrical product specifications (GPS) — Inspection by measurement of workpieces and measuring equipment — Part 1: Decision rules for proving conformity or nonconformity with specifications*
- [4] ISO 14406:2010, *Geometrical product specifications (GPS) — Extraction*
- [5] ISO/TR 14638:1995, *Geometrical product specification (GPS) — Masterplan*
- [6] WYANT J.C., & SCHMIT J. Large Field of View, High Spatial Resolution, Surface Measurements. *Int. J. Mach. Tools Manuf.* 1998, **38** (5-6) pp. 691–698

Focus variation instrument

- [7] SCHERER. S. Focus-Variation for optical 3D measurement in the micro- and nano-range. *Handbuch zur Industriellen Bildverarbeitung: Qualitätssicherung in der Praxis*; Fraunhofer IRB Verlag ISBN 978-3-8167-7386, 2007
- [8] DANZL. R., HELMLI, F., RUBERT, P. and PRANTL, M. *Optical roughness measurements on specially designed roughness standards*, *Proc. SPIE*, Glasgow, 2008, Vol. 7102, 71020M
- [9] NEUGEBAUER. M. and NEUSCHAEFER-RUBE, U. *A new micro artefact for testing of optical and tactile sensors*. *Proc. of 5th Euspen International Conference*, Montpellier, France, 2005, pp. 201-204
- [10] LEACH. R.K. *Optical Measurement of Surface Topography*. Springer Berlin Heidelberg, 2011, p. 340.
- [11] NAYAR. S.K., NAKAGAWA, Y. Shape from focus. *IEEE Trans. Pattern Anal. Mach. Intell.* **16** (8) p. 82

British Standards Institution (BSI)

BSI is the national body responsible for preparing British Standards and other standards-related publications, information and services.

BSI is incorporated by Royal Charter. British Standards and other standardization products are published by BSI Standards Limited.

About us

We bring together business, industry, government, consumers, innovators and others to shape their combined experience and expertise into standards-based solutions.

The knowledge embodied in our standards has been carefully assembled in a dependable format and refined through our open consultation process. Organizations of all sizes and across all sectors choose standards to help them achieve their goals.

Information on standards

We can provide you with the knowledge that your organization needs to succeed. Find out more about British Standards by visiting our website at bsigroup.com/standards or contacting our Customer Services team or Knowledge Centre.

Buying standards

You can buy and download PDF versions of BSI publications, including British and adopted European and international standards, through our website at bsigroup.com/shop, where hard copies can also be purchased.

If you need international and foreign standards from other Standards Development Organizations, hard copies can be ordered from our Customer Services team.

Subscriptions

Our range of subscription services are designed to make using standards easier for you. For further information on our subscription products go to bsigroup.com/subscriptions.

With **British Standards Online (BSOL)** you'll have instant access to over 55,000 British and adopted European and international standards from your desktop. It's available 24/7 and is refreshed daily so you'll always be up to date.

You can keep in touch with standards developments and receive substantial discounts on the purchase price of standards, both in single copy and subscription format, by becoming a **BSI Subscribing Member**.

PLUS is an updating service exclusive to BSI Subscribing Members. You will automatically receive the latest hard copy of your standards when they're revised or replaced.

To find out more about becoming a BSI Subscribing Member and the benefits of membership, please visit bsigroup.com/shop.

With a **Multi-User Network Licence (MUNL)** you are able to host standards publications on your intranet. Licences can cover as few or as many users as you wish. With updates supplied as soon as they're available, you can be sure your documentation is current. For further information, email bsmusales@bsigroup.com.

BSI Group Headquarters

389 Chiswick High Road London W4 4AL UK

Revisions

Our British Standards and other publications are updated by amendment or revision.

We continually improve the quality of our products and services to benefit your business. If you find an inaccuracy or ambiguity within a British Standard or other BSI publication please inform the Knowledge Centre.

Copyright

All the data, software and documentation set out in all British Standards and other BSI publications are the property of and copyrighted by BSI, or some person or entity that owns copyright in the information used (such as the international standardization bodies) and has formally licensed such information to BSI for commercial publication and use. Except as permitted under the Copyright, Designs and Patents Act 1988 no extract may be reproduced, stored in a retrieval system or transmitted in any form or by any means – electronic, photocopying, recording or otherwise – without prior written permission from BSI. Details and advice can be obtained from the Copyright & Licensing Department.

Useful Contacts:

Customer Services

Tel: +44 845 086 9001

Email (orders): orders@bsigroup.com

Email (enquiries): cservices@bsigroup.com

Subscriptions

Tel: +44 845 086 9001

Email: subscriptions@bsigroup.com

Knowledge Centre

Tel: +44 20 8996 7004

Email: knowledgecentre@bsigroup.com

Copyright & Licensing

Tel: +44 20 8996 7070

Email: copyright@bsigroup.com



...making excellence a habit.™