

BS EN ISO 25178-605:2014



BSI Standards Publication

# Geometrical product specifications (GPS) — Surface texture: Areal

Part 605: Nominal characteristics of non-contact (point autofocus probe) instruments

**bsi.**

...making excellence a habit.™

**National foreword**

This British Standard is the UK implementation of EN ISO 25178-605:2014.

The UK participation in its preparation was entrusted to Technical Committee TDW/4, Technical Product Realization.

A list of organizations represented on this committee can be obtained on request to its secretary.

This publication does not purport to include all the necessary provisions of a contract. Users are responsible for its correct application.

© The British Standards Institution 2014. Published by BSI Standards Limited 2014

ISBN 978 0 580 68207 0

ICS 17.040.20

**Compliance with a British Standard cannot confer immunity from legal obligations.**

This British Standard was published under the authority of the Standards Policy and Strategy Committee on 31 January 2014.

**Amendments issued since publication**

Date	Text affected
------	---------------

---

---

ICS 17.040.20

English Version

Geometrical product specifications (GPS) - Surface texture:  
Areal - Part 605: Nominal characteristics of non-contact (point  
autofocus probe) instruments (ISO 25178-605:2014)

Spécification géométrique des produits (GPS) - État de  
surface: Surfacique - Partie 605: Caractéristiques  
nominales des instruments sans contact (capteur autofocus  
à point) (ISO 25178-605:2014)

Geometrische Produktspezifikation (GPS) -  
Oberflächenbeschaffenheit: Flächenhaft - Teil 605:  
Merkmale von berührungslos messenden Geräten (Punkt-  
Autofokus-Sensor) (ISO 25178-605:2014)

This European Standard was approved by CEN on 13 January 2014.

CEN members are bound to comply with the CEN/CENELEC Internal Regulations which stipulate the conditions for giving this European Standard the status of a national standard without any alteration. Up-to-date lists and bibliographical references concerning such national standards may be obtained on application to the CEN-CENELEC Management Centre or to any CEN member.

This European Standard exists in three official versions (English, French, German). A version in any other language made by translation under the responsibility of a CEN member into its own language and notified to the CEN-CENELEC Management Centre has the same status as the official versions.

CEN members are the national standards bodies of Austria, Belgium, Bulgaria, Croatia, Cyprus, Czech Republic, Denmark, Estonia, Finland, Former Yugoslav Republic of Macedonia, France, Germany, Greece, Hungary, Iceland, Ireland, Italy, Latvia, Lithuania, Luxembourg, Malta, Netherlands, Norway, Poland, Portugal, Romania, Slovakia, Slovenia, Spain, Sweden, Switzerland, Turkey and United Kingdom.



EUROPEAN COMMITTEE FOR STANDARDIZATION  
COMITÉ EUROPÉEN DE NORMALISATION  
EUROPÄISCHES KOMITEE FÜR NORMUNG

**CEN-CENELEC Management Centre: Avenue Marnix 17, B-1000 Brussels**

## Foreword

This document (EN ISO 25178-605:2014) has been prepared by Technical Committee ISO/TC 213 "Dimensional and geometrical product specifications and verification" in collaboration with Technical Committee CEN/TC 290 "Dimensional and geometrical product specification and verification" the secretariat of which is held by AFNOR.

This European Standard shall be given the status of a national standard, either by publication of an identical text or by endorsement, at the latest by July 2014, and conflicting national standards shall be withdrawn at the latest by July 2014.

Attention is drawn to the possibility that some of the elements of this document may be the subject of patent rights. CEN [and/or CENELEC] shall not be held responsible for identifying any or all such patent rights.

According to the CEN-CENELEC Internal Regulations, the national standards organizations of the following countries are bound to implement this European Standard: Austria, Belgium, Bulgaria, Croatia, Cyprus, Czech Republic, Denmark, Estonia, Finland, Former Yugoslav Republic of Macedonia, France, Germany, Greece, Hungary, Iceland, Ireland, Italy, Latvia, Lithuania, Luxembourg, Malta, Netherlands, Norway, Poland, Portugal, Romania, Slovakia, Slovenia, Spain, Sweden, Switzerland, Turkey and the United Kingdom.

### Endorsement notice

The text of ISO 25178-605:2014 has been approved by CEN as EN ISO 25178-605:2014 without any modification.

# Contents

Page

<b>Foreword</b> .....	<b>iv</b>
<b>Introduction</b> .....	<b>vi</b>
<b>1 Scope</b> .....	<b>1</b>
<b>2 Normative references</b> .....	<b>1</b>
<b>3 Terms and definitions</b> .....	<b>1</b>
3.1 Terms and definitions related to all areal surface texture measurement methods.....	2
3.2 Terms and definitions related to x- and y-scanning systems.....	9
3.3 Terms and definitions related to optical systems.....	11
3.4 Terms and definitions related to optical properties of workpiece.....	12
3.5 Terms and definitions specific to point autofocus profiling.....	13
<b>4 Descriptions of the influence quantities</b> .....	<b>14</b>
4.1 General.....	14
4.2 Influence quantities.....	14
<b>Annex A (informative) General principles</b> .....	<b>16</b>
<b>Annex B (informative) Spot size and focal shift</b> .....	<b>20</b>
<b>Annex C (informative) Beam offset direction and maximum acceptable local slope</b> .....	<b>23</b>
<b>Annex D (informative) Features of an areal surface texture measuring instrument</b> .....	<b>26</b>
<b>Annex E (informative) Others: Non-measured point (autofocus error)</b> .....	<b>28</b>
<b>Annex F (informative) Relation to the GPS matrix</b> .....	<b>29</b>
<b>Bibliography</b> .....	<b>31</b>

## Foreword

ISO (the International Organization for Standardization) is a worldwide federation of national standards bodies (ISO member bodies). The work of preparing International Standards is normally carried out through ISO technical committees. Each member body interested in a subject for which a technical committee has been established has the right to be represented on that committee. International organizations, governmental and non-governmental, in liaison with ISO, also take part in the work. ISO collaborates closely with the International Electrotechnical Commission (IEC) on all matters of electrotechnical standardization.

The procedures used to develop this document and those intended for its further maintenance are described in the ISO/IEC Directives, Part 1. In particular the different approval criteria needed for the different types of ISO documents should be noted. This document was drafted in accordance with the editorial rules of the ISO/IEC Directives, Part 2. [www.iso.org/directives](http://www.iso.org/directives)

Attention is drawn to the possibility that some of the elements of this document may be the subject of patent rights. ISO shall not be held responsible for identifying any or all such patent rights. Details of any patent rights identified during the development of the document will be in the Introduction and/or on the ISO list of patent declarations received. [www.iso.org/patents](http://www.iso.org/patents)

Any trade name used in this document is information given for the convenience of users and does not constitute an endorsement.

For an explanation on the meaning of ISO specific terms and expressions related to conformity assessment, as well as information about ISO's adherence to the WTO principles in the Technical Barriers to Trade (TBT) see the following URL: [Foreword - Supplementary information](#)

The committee responsible for this document is ISO/TC 213, *Dimensional and geometrical product specifications and verification*.

ISO 25178 consists of the following parts, under the general title *Geometrical product specifications (GPS) — Surface texture: Areal*:

- *Part 1: Indication of surface texture*
- *Part 2: Terms, definitions and surface texture parameters*
- *Part 3: Specification operators*
- *Part 6: Classification of methods for measuring surface texture*
- *Part 70: Material measures*
- *Part 71: Software measurement standards*
- *Part 601: Nominal characteristics of contact (stylus) instruments*
- *Part 602: Nominal characteristics of non-contact (confocal chromatic probe) instruments*
- *Part 603: Nominal characteristics of non-contact (phase-shifting interferometric microscopy) instruments*
- *Part 604: Nominal characteristics of non-contact (coherence scanning interferometry) instruments*
- *Part 605: Nominal characteristics of non-contact (point autofocus probe) instruments*
- *Part 606: Nominal characteristics of non-contact (focus variation) instruments*
- *Part 701: Calibration and measurement standards for contact (stylus) instruments*

The following parts are under preparation:

— *Part 72: XML file format x3p*

Calibration and measurement standards for non-contact (confocal chromatic probe) instruments and calibration and measurement standards for non-contact (phase-shifting interferometric microscopy) instruments are to form the subject of future parts 702 and 703.

A part 600 is planned which is intended to contain provisions common with the other 600-level parts of ISO 25178. Once it has been submitted as a Final Draft International Standard, those provisions in the other 600-level parts that are then redundant will be removed from them.

## Introduction

This part of ISO 25178 is a Geometrical Product Specification standard and is to be regarded as a General GPS standard (see ISO/TR 14638). It influences the chain link 5 of the chains of standards on roughness profile, waviness profile, primary profile, and areal surface texture.

For more detailed information on the relationship of this standard to the GPS matrix model, see Annex G.

The ISO/GPS Masterplan given in ISO/TR 14638 gives an overview of the ISO/GPS system of which this standard is a part. The fundamental rules of ISO/GPS given in ISO 8015 apply to this standard and the default decision rules given in ISO 14253-1 apply to specifications made in accordance with this standard, unless otherwise indicated.

The point autofocus optical principle can be implemented in various set-ups. The configuration described in this document comprises three basic elements: an autofocus optical system, an autofocus mechanism, and an electronic controller.

This type of instrument is mainly designed for areal measurements, but it is also able to perform profile measurements.

This part of ISO 25178 describes the metrological characteristics of an optical profiler using a point autofocus probe for the measurement of areal surface texture.

For more detailed information on the point autofocus method, see [Annex A](#). Reading this annex before the main body may lead to a better understanding of this standard.



# Geometrical product specifications (GPS) — Surface texture: Areal —

## Part 605: Nominal characteristics of non-contact (point autofocus probe) instruments

### 1 Scope

This part of ISO 25178 describes the metrological characteristics of a non-contact instrument for measuring surface texture using point autofocus probing.

### 2 Normative references

The following documents, in whole or in part, are normatively referenced in this document and are indispensable for its application. For dated references, only the edition cited applies. For undated references, the latest edition of the referenced document (including any amendments) applies.

ISO 4287:1997, *Geometrical Product Specifications (GPS) — Surface texture: Profile method — Terms, definitions and surface texture parameters*

ISO 10360-1, *Geometrical Product Specifications (GPS) — Acceptance and reverification tests for coordinate measuring machines (CMM) — Part 1: Vocabulary*

ISO 14406:2010, *Geometrical product specifications (GPS) — Extraction*

ISO 14978:2006, *Geometrical product specifications (GPS) — General concepts and requirements for GPS measuring equipment*

ISO 25178-2:2012, *Geometrical product specifications (GPS) — Surface texture: Areal — Part 2: Terms, definitions and surface texture parameters*

ISO 25178-3:2012, *Geometrical product specifications (GPS) — Surface texture: Areal — Part 3: Specification operators*

ISO 25178-6:2010, *Geometrical product specifications (GPS) — Surface texture: Areal — Part 6: Classification of methods for measuring surface texture*

ISO 25178-601:2010, *Geometrical product specifications (GPS) — Surface texture: Areal — Part 601: Nominal characteristics of contact (stylus) instruments*

ISO 25178-602:2010, *Geometrical product specifications (GPS) — Surface texture: Areal — Part 602: Nominal characteristics of non-contact (confocal chromatic probe) instruments*

### 3 Terms and definitions

For the purposes of this document, the terms and definitions given in ISO 4287, ISO 10360-1, ISO 14406, ISO 14978, ISO 25178-2, ISO 25178-3, ISO 25178-6, ISO 25178-601, ISO 25178-602 and the following apply.

### 3.1 Terms and definitions related to all areal surface texture measurement methods

#### 3.1.1

##### areal reference

component of the instrument that generates a reference surface with respect to which the surface topography is measured

#### 3.1.2

##### coordinate system of the instrument

right hand orthonormal system of axes  $(x,y,z)$

Note 1 to entry: In this system  $(x,y)$  is the plane established by the areal reference of the instrument (Note that there are optical instruments that do not possess a physical areal guide).

Note 2 to entry: In this system,  $z$ -axis is mounted parallel to the optical axis and is perpendicular to the  $(x,y)$  plane for an optical instrument. The  $z$ -axis is in the plane of the stylus trajectory and is perpendicular to the  $(x,y)$  plane for a stylus instrument (see [Figure 1](#))

Note 3 to entry: Normally, the  $x$ -axis is the tracing axis and the  $y$ -axis is the stepping axis. (This note is valid for instruments that scan in the horizontal plane.)

Note 4 to entry: See also *specification coordinate system* and *measurement coordinate system*, as defined in ISO 25178-2:2012, 3.1.2 and ISO 25178-6:2010, 3.1.1, respectively.

#### 3.1.3

##### measurement loop

closed chain which comprises all components connecting the workpiece and the probe, e.g. the means of positioning, the work holding fixture, the measuring stand, the drive unit, the probing system

Note 1 to entry: See [Figure 1](#). The measurement loop will be subjected to external and internal disturbances that influence the measurement uncertainty.

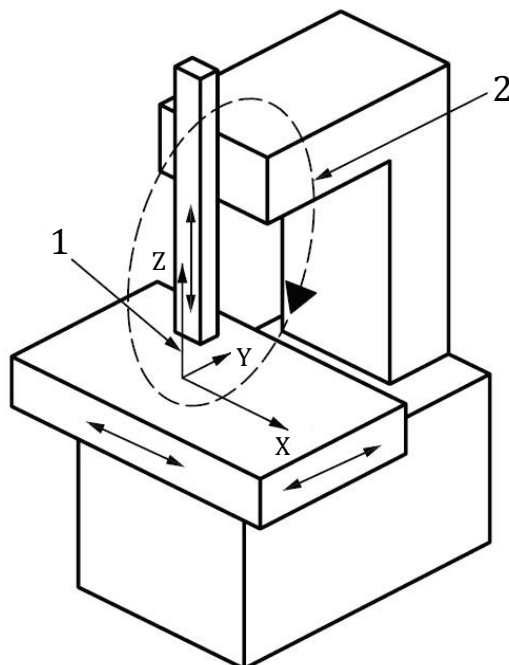

#### Key

- 1 coordinate system of the instrument
- 2 measurement loop

**Figure 1 — Coordinate system and measurement loop of instrument**

### 3.1.4

#### **real surface of a workpiece**

set of features which physically exist and separate the entire workpiece from the surrounding medium

[SOURCE: ISO 14660-1:1999, 2.4]

Note 1 to entry: The real surface is a mathematical representation of the surface that is independent of the measurement process.

Note 2 to entry: See also *mechanical surface*, as defined in ISO 25178-2:2012, 3.1.1.1 or ISO 14406:2010, 3.1.1, and *electromagnetic surface*, as defined in ISO 25178-2:2012, 3.1.1.2 or ISO 14406:2010, 3.1.2.

Note 3 to entry: The electromagnetic surface considered for one type of optical instrument may be different from the electromagnetic surface for other types of optical instruments.

### 3.1.5

#### **surface probe**

device that converts the surface height into a signal during measurement

Note 1 to entry: In earlier standards this was termed transducer.

### 3.1.6

#### **measuring volume**

range of the instrument stated in terms of the limits on all three coordinates measured by the instrument

Note 1 to entry: For areal surface texture measuring instruments, the measuring volume is defined by:

— the measuring range of the  $x$ - and  $y$ - drive units,

— the measuring range of the  $z$ -probing system.

[SOURCE: ISO 25178-601:2010, 3.4.1]

### 3.1.7

#### **response curve**

$F_x, F_y, F_z$

graphical representation of the function that describes the relation between the actual quantity and the measured quantity

Note 1 to entry: See [Figure 2](#).

Note 2 to entry: An actual quantity in  $x$  (respectively  $y$  or  $z$ ) corresponds to a measured quantity  $x_M$  (respectively  $y_M$  or  $z_M$ ).

Note 3 to entry: The response curve can be used for adjustments and error corrections.

[SOURCE: ISO 25178-601:2010, 3.4.2]

### 3.1.8

#### **amplification coefficient**

$\alpha_x, \alpha_y, \alpha_z$

slope of the linear regression curve obtained from the response curve

Note 1 to entry: See [Figure 3](#).

Note 2 to entry: There will be amplification coefficients applicable to the  $x, y$  and  $z$  quantities.

Note 3 to entry: The ideal response is a straight line with a slope equal to 1 which means that the values of the measurand are equal to the values of the input quantities.

Note 4 to entry: See also *sensitivity of a measuring system* (VIM, 4.12)<sup>[1]</sup>

[ISO 25178-601:2010, 3.4.3, modified — Note 4 has been added.]

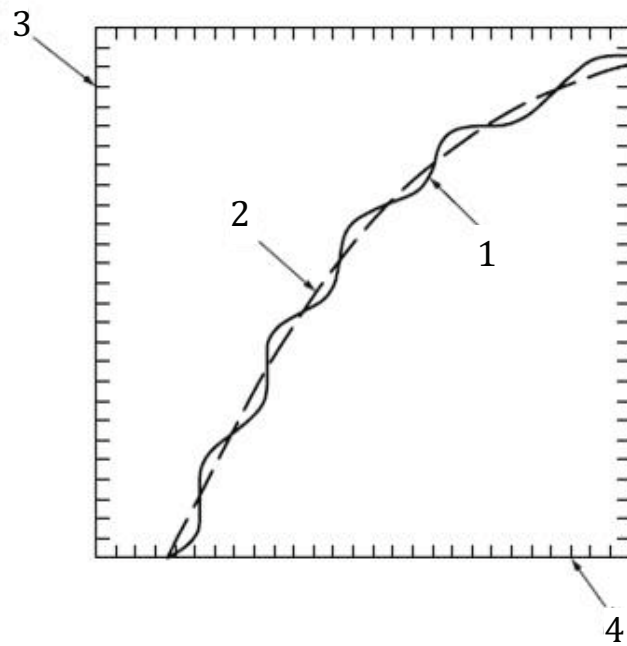

**Key**

- 1 response curve
- 2 assessment of the linearity deviation by polynomial approximation
- 3 measured quantities
- 4 input quantities

**Figure 2 — Example of nonlinear response curve**

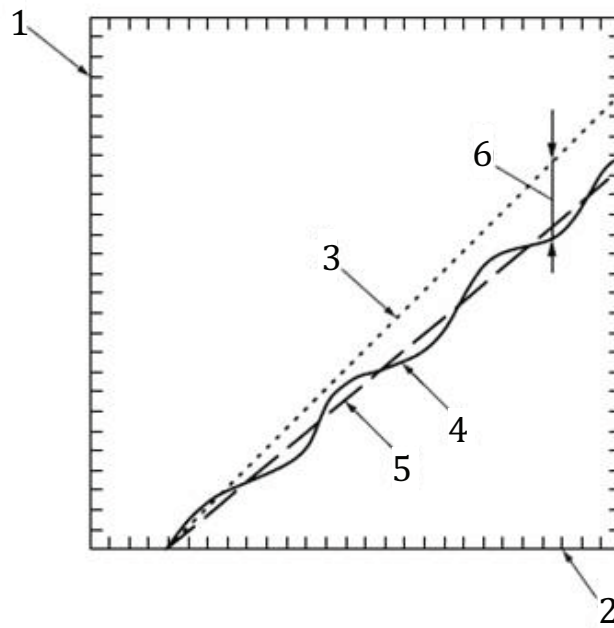

**Key**

- 1 measured quantities
- 2 input quantities
- 3 ideal response curve
- 4 linearization of the response curve of [Figure 2](#)
- 5 line from which the amplification coefficient  $\alpha$  (slope) is derived
- 6 local residual correction error

**Figure 3 — Example of linearization of response curve**

**3.1.9  
 instrument noise**

$N_I$

internal noise added to the output signal caused by the instrument if ideally placed in a noise-free environment

Note 1 to entry: Internal noise can be due to electronic noise, as e.g. amplifiers, or to optical noise, as e.g. stray light.

Note 2 to entry: This noise typically has high frequencies and it limits the ability of the instrument to detect small scale spatial wavelengths of the surface texture.

Note 3 to entry: The S-filter according ISO 25178-3 may reduce this noise.

Note 4 to entry: For some instruments, instrument noise cannot be estimated because the instrument only takes data while moving.

**3.1.10  
 measurement noise**

$N_M$

noise added to the output signal occurring during the normal use of the instrument

Note 1 to entry: Notes 2 and 3 of [3.1.9](#) apply as well to this definition.

Note 2 to entry: Measurement noise includes the instrument noise.

### 3.1.11

#### surface topography repeatability

repeatability of topography map in successive measurements of the same surface under the same conditions of measurement

Note 1 to entry: Surface topography repeatability provides a measure of the likely agreement between repeated measurements normally expressed as a standard deviation

Note 2 to entry: See VIM, [1] 2.15 and 2.21, for a general discussion of repeatability and related concepts.

Note 3 to entry: Evaluation of surface topography repeatability is a common method for determining the measurement noise.

### 3.1.12

#### sampling interval in $x$ [ $y$ ]

$D_x$  [ $D_y$ ]

distance between two adjacent measured points along the  $x$ - [ $y$ -] axis

Note 1 to entry: In many microscopy systems the sampling interval is determined by the distance between sensor elements in a camera, called *pixels*. For such systems, the terms *pixel pitch* and *pixel spacing* are often used interchangeably with the term *sampling interval*. Another term, *pixel width*, indicates a length associated with one side ( $x$  or  $y$ ) of the sensitive area of a single pixel and is always smaller than the pixel spacing. Yet another term, *sampling zone*, may be used to indicate the length or region over which a height sample is determined. This quantity could either be larger or smaller than the sampling interval.

### 3.1.13

#### digitisation step in $z$

$D_z$

smallest height variation along the  $z$ -axis between two ordinates of the extracted surface

### 3.1.14

#### lateral resolution

$R_l$

smallest distance between two features which can be detected

[SOURCE: ISO 25178-601:2010, 3.4.10]

### 3.1.15

#### width limit for full height transmission

$W_l$

width of the narrowest rectangular groove whose measured height remains unchanged by the measurement

Note 1 to entry: Instrument properties such as

- the sampling interval in  $x$  and  $y$ ,
- the digitisation step in  $z$ , and
- the short wavelength cut-off filter

should be chosen so that they do not influence the lateral resolution and the width limit for full height transmission.

Note 2 to entry: When determining this parameter by measurement, the depth of the rectangular groove should be close to that of the surface to be measured.

Note 3 to entry: An example is the measuring of a grid for which the grooves are wider than the width limit for full height transmission. This leads to a correct measurement of the groove depth (see [Figures 4](#) and [5](#)).

Note 4 to entry: Another example is the measuring of a grid for which the grooves are narrower than the *width limit for full height transmission*. This leads to an incorrect groove depth (see [Figures 6](#) and [7](#)). In this situation, the signal is generally disturbed and may contain non-measured points.

[ISO 25178-601:2010, 3.4.11, modified — The original notes have been replaced.]

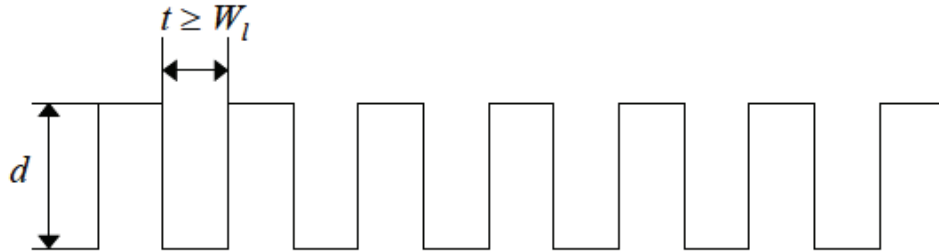

Figure 4 — Grid with horizontal spacing and  $t$  greater than or equal to  $W_l$

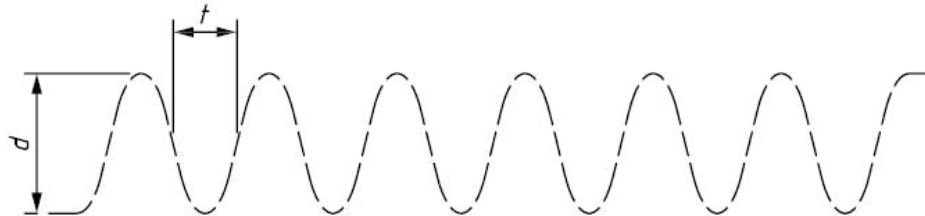

Figure 5 — Measurement of grid in [Figure 4](#) — Spacing and depth of grid measured correctly

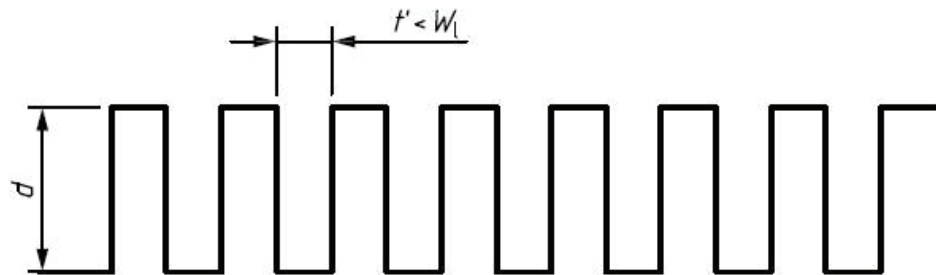

Figure 6 — Grid with horizontal spacing and  $t'$  smaller than  $W_l$



Figure 7 — Measurement of grid in [Figure 6](#) — Spacing measured correctly but depth smaller ( $d' < d$ )

### 3.1.16 lateral period limit

$D_{LIM}$

spatial period of a sinusoidal profile at which the height response of an instrument falls to 50 %

Note 1 to entry: The lateral period limit is one metric for describing spatial or lateral resolution of a surface topography measuring instrument and its ability to distinguish and measure closely spaced surface features. Its value depends on the heights of surface features and on the method used to probe the surface. Maximum values for this parameter are listed in ISO 25178-3:2012, [Table 3](#), in comparison with recommended values for short wavelength (s-)filters and sampling intervals.

Note 2 to entry: Spatial period is the same concept as spatial wavelength and is the inverse of spatial frequency.

Note 3 to entry: One factor related to the value of  $D_{LIM}$  for optical tools is the *Rayleigh criterion* ([3.3.7](#)). Another is the degree of focus of the objective on the surface.

Note 4 to entry: One factor related to the value of  $D_{LIM}$  for contact tools is the stylus tip radius,  $r_{TIP}$  (see ISO 25178-601).

Note 5 to entry: Other terms related to lateral period limit are structural resolution and topographic spatial resolution

### 3.1.17 maximum local slope

greatest local slope of a surface feature that can be assessed by the probing system

Note 1 to entry: The term *local slope* is defined in ISO 4287:1997, 3.2.9.

### 3.1.18 instrument transfer function

ITF

$f_{ITF}$

function of spatial frequency describing how a surface topography measuring instrument responds to an object surface topography having a specific spatial frequency

Note 1 to entry: Ideally, the ITF tells us what the measured amplitude of a sinusoidal grating of a specified spatial frequency,  $\nu$ , would be relative to the true amplitude of the grating.

Note 2 to entry: For several types of optical instruments, the ITF may be a nonlinear function of height except for heights much smaller than the optical wavelength.

### 3.1.19 hysteresis

$X_{HYS}$ ,  $Y_{HYS}$ ,  $Z_{HYS}$

property of measuring equipment or characteristic whereby the indication of the equipment or value of the characteristic depends on the orientation of the preceding stimuli

Note 1 to entry: Hysteresis can also depend, for example, on the distance travelled after the orientation of stimuli has changed.

Note 2 to entry: For lateral scanning systems, the hysteresis is mainly a repositioning error.

[SOURCE: ISO 14978:2006, 3.24]

### 3.1.20 metrological characteristic

<measuring equipment> characteristic of measuring equipment, which may influence the results of measurement

Note 1 to entry: Calibration of metrological characteristics may be necessary.

Note 2 to entry: The metrological characteristics have an immediate contribution to measurement uncertainty.



Note 3 to entry: Metrological characteristics for areal surface texture measuring instruments are given in [Table 1](#).  
[ISO 14978:2006, 3.12, modified — The original notes have been replaced.]

**Table 1 — List of metrological characteristics for surface texture measurement methods**

Metrological characteristic	Symbol	Definition	Main potential error along
Amplification coefficient	$\alpha_x, \alpha_y, \alpha_z$	<a href="#">3.1.8</a> (see <a href="#">Figure 3</a> )	$x, y, z$
Linearity deviation	$l_x, l_y, l_z$	Maximum local difference between the line from which the amplification coefficient is derived (see <a href="#">Figure 3</a> , key item 5) and the response curve (see <a href="#">Figure 3</a> , key item 4)	$x, y, z$
Residual flatness	$z_{FLT}$	Flatness of the areal reference	$z$
Measurement noise	$N_M$	<a href="#">3.1.10</a>	$z$
Lateral period limit	$D_{LIM}$	<a href="#">3.1.16</a>	$z$
Perpendicularity	$\Delta_{PERxy}$	Deviation from 90° of the angle between the $x$ - and $y$ -axes	$x, y$

## 3.2 Terms and definitions related to $x$ - and $y$ -scanning systems

### 3.2.1

#### areal reference guide

component(s) of the instrument that generate(s) the reference surface, in which the probing system moves relative to the surface being measured according to a theoretically exact trajectory

Note 1 to entry: Note to entry: In the case of  $x$ - and  $y$ -scanning areal surface texture measuring instruments, the areal reference guide establishes a reference surface [ISO 25178-2:2012, 3.1.8]. It can be achieved through the use of two linear and perpendicular reference guides [ISO 3274:1996, 3.3.2] or one reference surface guide.

### 3.2.2

#### lateral scanning system

system that performs the scanning of the surface to be measured in the  $(x,y)$  plane

Note 1 to entry: There are essentially four aspects to a surface texture scanning instrument system: the  $x$ -axis drive, the  $y$ -axis drive, the  $z$ -measurement probe and the surface to be measured. There are different ways in which these may be configured and thus there will be a difference between different configurations as explained in [Table 2](#).

Note 2 to entry: When a measurement consists of a single field of view of a microscope,  $x$ - and  $y$ -scanning is not used. However, when several fields of view are linked together by *stitching* methods [2], the system is considered to be a scanning system.

**Table 2 — Possible different configurations for reference guides (x and y)**

		Drive unit				
		Two reference guides (x and y)			One areal reference guide	
		Px o Cy	Px o Py	Cx o Cy	Pxy	Cxy
Probing system	A: without arcuate error correction	Px o Cy-A	Px o Py-A	Cx o Cy-A	Pxy-A	Cxy-A
	S: without arcuate error or with arcuate error corrected	Px o Cy-S	Px o Py-S	Cx o Cy-S	Pxy-S	Cxy-S

For two given functions, f and g, f o g is the combination of these functions.  
 Px = probing systems moving along the x-axis  
 Py = probing systems moving along the y-axis  
 Cx = component moving along the x-axis  
 Cy = component moving along the y-axis

**3.2.3**  
**drive unit x [y]**

component of the instrument that moves the probing system or the surface being measured along the reference guide on the x-axis [y-axis] and returns the horizontal position of the measured point in terms of the lateral x-coordinate [y-coordinate] of the profile

**3.2.4**  
**lateral position sensor**

component of the drive unit that provides the lateral position of the measured point

Note 1 to entry: The lateral position can be measured or inferred by using, for example, a linear encoder, a laser interferometer, or a counting device coupled with a micrometre screw.

**3.2.5**  
**speed of measurement**

$V_x$   
 speed of the probing system relative to the surface to be measured during the measurement along the x-axis

[SOURCE: ISO 25178-601:2010, 3.4.13]

**3.2.6**  
**static noise**

$N_S$   
 combination of the instrument and environmental noise on the output signal when the instrument is not scanning laterally

Note 1 to entry: Environmental noise is caused by e.g. seismic, sonic and external electromagnetic disturbances.

Note 2 to entry: Notes 2 and 3 in [3.1.9](#) apply to this definition.

Note 3 to entry: Static noise is included in *measurement noise* ([3.1.10](#))

**3.2.7**  
**dynamic noise**

$N_D$   
 noise occurring during the motion of the drive units on the output signal

Note 1 to entry: Notes 2 and 3 in [3.1.9](#) apply to this definition.

Note 2 to entry: Dynamic noise includes the static noise.

Note 3 to entry: Dynamic noise is included in *measurement noise* ([3.1.10](#)).

### 3.3 Terms and definitions related to optical systems

#### 3.3.1

##### light source

optical device emitting an appropriate range of wavelengths in a specified spectral region

#### 3.3.2

##### measurement optical bandwidth

$B_{\lambda 0}$

range of wavelengths of light used to measure a surface

Note 1 to entry: Instruments may be constructed with light sources with a limited optical bandwidth and/or with additional filter elements to further limit the optical bandwidth.

#### 3.3.3

##### measurement optical wavelength

$\lambda_0$

effective value of the wavelength of the light used to measure a surface

Note 1 to entry: The measurement optical wavelength is affected by conditions such as the light source spectrum, spectral transmission of the optical components, and spectral response of the image sensor array.

#### 3.3.4

##### angular aperture

angle of the cone of light entering an optical system from a point on the surface being measured

[SOURCE: ISO 25178-602:2010, 3.3.3]

#### 3.3.5

##### half aperture angle

$\alpha$

one half of the angular aperture

Note 1 to entry: This angle (see [Figure 8](#)) is sometimes also called *half cone angle*.

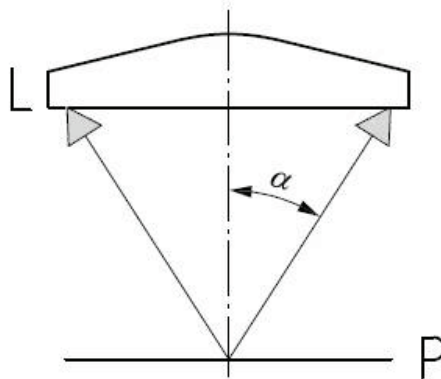

##### Key

L lens or optical system

P focal point

$\alpha$  half aperture angle

Figure 8 — Half aperture angle

### 3.3.6 numerical aperture

$A_N$   
sine of the half aperture angle multiplied by the refractive index  $n$  of the surrounding medium ( $A_N = n \sin\alpha$ )

Note 1 to entry: In air for visible light,  $n \cong 1$ .

Note 2 to entry: The numerical aperture is dependent on the wavelength of light. Typically the numerical aperture is specified for the wavelength that is in the middle of the measurement optical bandwidth.

### 3.3.7 Rayleigh criterion

quantity characterizing the spatial resolution of an optical system given by the separation of two point sources at which the first diffraction minimum of the image of one point source coincides with the maximum of the other

Note 1 to entry: For a theoretically perfect, incoherent optical system with a filled objective pupil, the Rayleigh criterion of the optical system is equal to  $0,61 \lambda_0/A_N$ .

Note 2 to entry: This parameter is useful for characterizing the instrument response to features with heights much less than  $\lambda_0$  for optical 3D metrology instruments.

### 3.3.8 Sparrow criterion

quantity characterizing the spatial resolution of an optical system given by the separation of two point sources at which the second derivative of the intensity distribution vanishes between the two imaged points

Note 1 to entry: For a theoretically perfect, incoherent optical system with a filled objective pupil, the Sparrow criterion of the optical system is equal to  $0,47 \lambda_0/A_N$ , approximately 0,77 times the *Rayleigh criterion* (3.3.7).

Note 2 to entry: This parameter is useful for characterizing the instrument response to features with heights much less than  $\lambda_0$  for optical 3D metrology instruments.

Note 3 to entry: Under the same measurement conditions as the notes above, the Sparrow criterion is nearly equal to the spatial period of  $0,50 \lambda_0/A_N$ , for which the theoretical instrument response falls to zero.

## 3.4 Terms and definitions related to optical properties of workpiece

### 3.4.1 surface film

surface layer  
material deposited onto another surface whose optical properties are different from that surface

### 3.4.2 thin film

film whose thickness is such that the top and bottom surfaces cannot be readily separated by the optical measuring system

Note 1 to entry: For some measurement systems with special properties and algorithms, the thicknesses of thin films may be derived.

### 3.4.3 thick film

film whose thickness is such that the top and bottom surfaces can be readily separated by the optical measuring system

#### 3.4.4

##### **optically smooth surface**

surface from which the reflected light is primarily specular and scattered light is not significant

Note 1 to entry: An optically smooth surface behaves locally like a mirror.

Note 2 to entry: A surface that acts as optically smooth under certain conditions, such as wavelength range, numerical aperture, pixel resolution, etc., can act as optically rough when one or more of these conditions change.

#### 3.4.5

##### **optically rough surface**

surface that does not behave as an optically smooth surface, i.e. where scattered light is significant

Note 1 to entry: A surface that acts as optically rough under certain conditions, such as wavelength range, numerical aperture, pixel resolution, etc., can act as optically smooth when one or more of these conditions change.

#### 3.4.6

##### **optically non-uniform material**

sample with different optical properties in different regions

Note 1 to entry: An optically non-uniform material may result in measured phase differences across the field of view that can be erroneously interpreted as differences in surface height.

### 3.5 Terms and definitions specific to point autofocus profiling

#### 3.5.1

##### **probing system**

<surface texture, point autofocus probe> components of the instrument called *point autofocus probe*, consisting of an autofocus optical system, an autofocus mechanism and an electronic controller

#### 3.5.2

##### **point autofocus probe**

device that converts the height of a point on a surface into a signal during measurement using the autofocus function

#### 3.5.3

##### **point autofocus profiling**

surface topography measurement method whereby the local surface height is measured by automatically centring a focused light beam reflected from the sample onto a position sensitive detector as a function of surface height

[SOURCE: ISO 25178-6:2010, 3.3.11]

#### 3.5.4

##### **objective**

objective lens that focuses the light source image on to the workpiece surface

#### 3.5.5

##### **autofocus sensor**

optical sensor that detects a focal position using the reflected light from the workpiece surface

#### 3.5.6

##### **autofocus mechanism**

autofocus driving mechanism that positions optical elements or the whole optical system

#### 3.5.7

##### **z position sensor**

sensor that measures the vertical position of the measured point

**3.5.8**  
**working distance**

<point autofocus probe> distance measured along the optical axis between the element closest to the surface and the focus point on the surface

**3.5.9**  
**spot size**

$W_{\text{spot}}$   
<point autofocus probe> size that forms the focus image of the light source on the workpiece surface

**3.5.10**  
**focus range**

range of  $z$  height, within which the focusing point exists

Note 1 to entry: Range where the autofocus sensor can detect the extreme defocused points.

**3.5.11**  
**vertical range**

$R_{\text{VERT}}$   
<point autofocus probe> measuring range that can output digital data with demonstrated measuring accuracy along a vertical direction in the movable range of the autofocus mechanism

**3.5.12**  
**measurable minimum reflection ratio**

$M_{\text{REF}}$   
minimum ratio of the reflected light intensity to the incident light intensity for a measurable workpiece surface

**3.5.13**  
**autofocus repeatability**

$R_{\text{AF}}$   
measurement repeatability of the autofocus function that does not include environmental noise

**3.5.14**  
**speckle noise**

uneven reflected optical intensity generated by irregular micro-scale geometry within the spot size

## 4 Descriptions of the influence quantities

### 4.1 General

Point autofocus probe instruments provide a measurement of lateral ( $x$  and  $y$ ) and height ( $z$ ) values from which surface texture parameters are calculated. Point autofocus probe instruments use the following measurement process.

The instrument measures surface texture by automatically focusing a laser beam on a point on the workpiece surface, moving the workpiece surface in a fixed measurement pitch using an  $x$ - $y$  scanning stage, and measuring the workpiece surface height at each focused point (see [Annex A](#)).

### 4.2 Influence quantities

Influence quantities for point autofocus probe instruments are given in [Table 3](#). The table indicates the metrological characteristics (see [3.1.20](#) and [Table 1](#)) that are affected by deviations of influence quantities.

**Table 3 — Influence quantities**

Component	Element	Influence quantities		Metrological characteristic affected ...
Probing system	Light source	$\lambda_0$	Measurement optical wavelength	$D_{LIM}$
	Autofocus probe	$W_{spot}$	Spot size	$D_{LIM}$
		$A_N$	Numerical aperture	$D_{LIM}$
		$M_{REF}$	Measurable minimum reflection ratio	$N_M$
		$R_{AF}$	Autofocus repeatability	$N_M$
		$D_z$	Height digitisation step	$N_M$
Drive unit	Position sensor (linear scale, encoder, ...)	$\delta_x$	x position sensor resolution	$D_{LIM}$
		$\delta_y$	y position sensor resolution	$D_{LIM}$
		$\delta_z$	z position sensor resolution	$N_M$
	Areal reference guide (height component)	$z_{STR(x)}$	Height component (z-axis direction) of the straightness of the stage movement along the x-axis	$z_{FLT}$
		$z_{STR(y)}$	Height component (z-axis direction) of the straightness of the stage movement along the y-axis	$z_{FLT}$
	Areal reference guide (lateral component)	$x_{STR(y)}$	Lateral component x of the straightness of the stage movement along the y axis (twist)	$\Delta_{PER_{xy}}, l_y$
		$y_{STR(x)}$	Lateral component y of the straightness of the stage movement along the x axis (twist)	$\Delta_{PER_{xy}}, l_x$
Instrument		$D_x$ or $D_y$	Lateral sampling interval, equal to the lateral scanning pitch of the x-y scanning stage	$D_{LIM}$
		$N_S$	Static noise	$N_M$
		$N_D$	Dynamic noise	$N_M$
		$N_{VIB}$	Environmental Vibration: unwanted motion between the surface being measured and the optical system.	$N_M$
Sample		$\theta_{TLT}^a$	Tilt: relative angle between the optical axis of the system and the sample normal	$\alpha_x, \alpha_y, \alpha_z$
		$\Phi_{DIS}^a$	The relative phase shift upon reflection of dissimilar materials	$\alpha_z$
		$T_{FLM}^a$	Thickness of transparent or semi-transparent films. These films typically have thickness comparable to the illumination wavelength. Note that thinner contamination or native oxide films do not necessarily affect the phase measurement process.	$\alpha_z$

<sup>a</sup> These influence quantities affect the calculation of areal parameters but should not influence the metrological characteristics described in [Table 1](#).

## Annex A (informative)

### General principles

#### A.1 Introduction

A point autofocus profiling instrument measures surface texture by automatically focusing a laser beam on to a point on the specimen surface, moving the specimen surface with a fixed measurement pitch using an  $x$ - $y$  scanning stage, and measuring the specimen surface height at each focused point.

#### A.2 Principle of a typical point autofocus probe

[Figure A.1](#) illustrates a typical optical system for point autofocus probing. A laser beam that can be focused to a small spot is generally used for the light source. The laser beam passes through the left-hand side of the objective and focuses on to the workpiece surface at the centre of the optical axis. The reflected laser beam passes through the right-hand side of the objective and forms an image on the autofocus sensor after passing through the imaging lens. [Figure A.1](#) shows the “in-focus” state.

[Figure A.2](#) shows the principle of the autofocus operation. 1) shows the in-focus state. 2) shows the defocus state. When the workpiece surface is displaced downward, the laser beam position on the autofocus sensor changes accordingly. The autofocus sensor detects the laser spot position; hence, the sensor detects the laser spot displacement and feeds this information back to the autofocus mechanism in order to adjust the objective to the in-focus position. The workpiece surface displacement ( $z_1$ ) is equal to the moving distance of the objective ( $z_2$ ), and the vertical position sensor (typically a linear position scale is used) obtains the height information of the workpiece (3). A distinctive feature of the point autofocus probe is that it is not influenced by the colour or reflection coefficients of workpiece surfaces since the autofocus sensor detects the position of the laser spot, not the intensity. Also, point autofocus probes have a wide measuring range and high resolution in the  $z$  coordinate, which is equivalent to the movable range and repeatability of the autofocus mechanism.



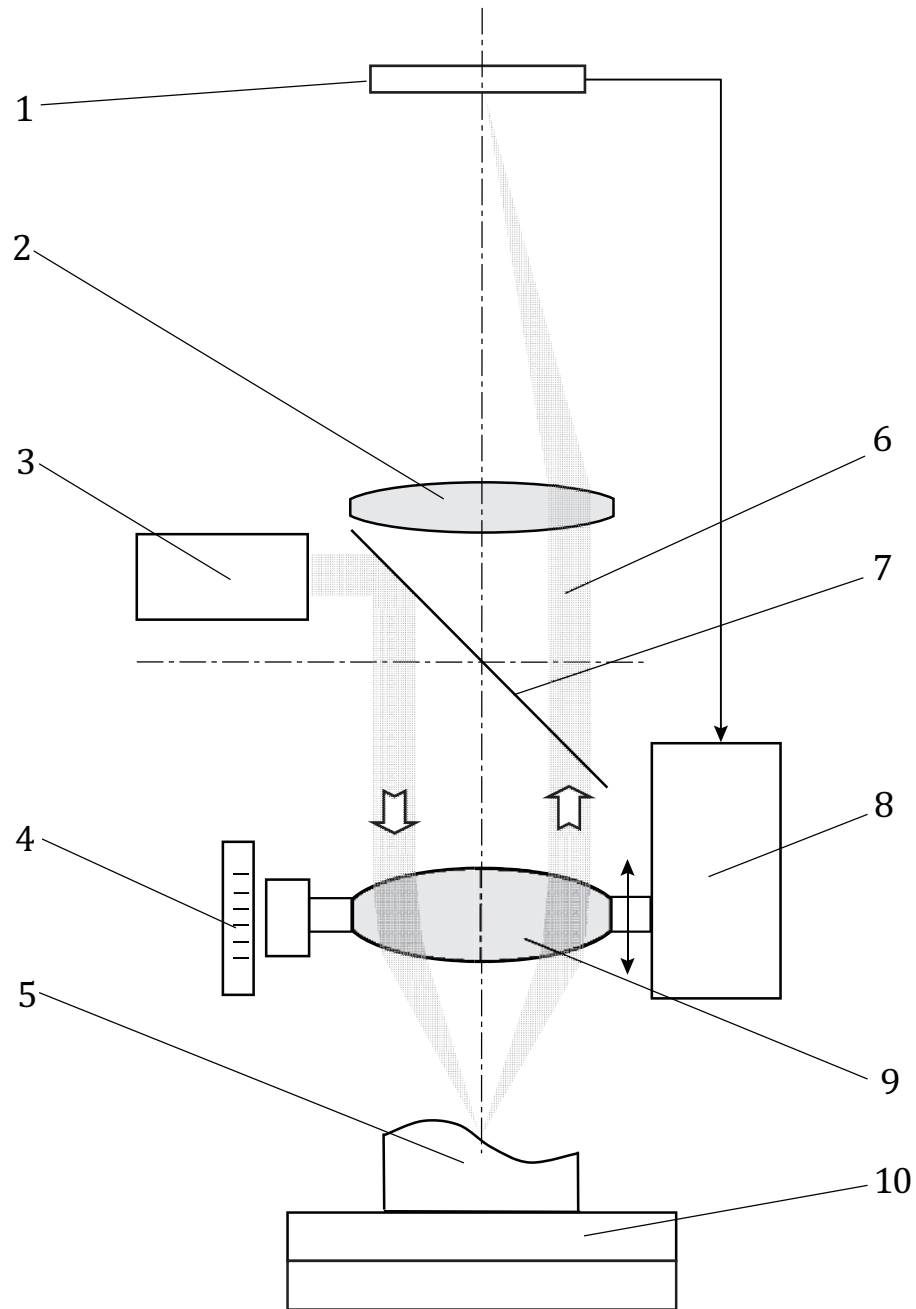

**Key**

- 1 autofocus sensor
- 2 image lens
- 3 light source
- 4 vertical positioning sensor
- 5 workpiece
- 6 laser beam
- 7 half mirror
- 8 autofocus mechanism
- 9 objective
- 10 x-y scanning stage

**Figure A.1 — Schematic diagram of a typical point autofocus probe**

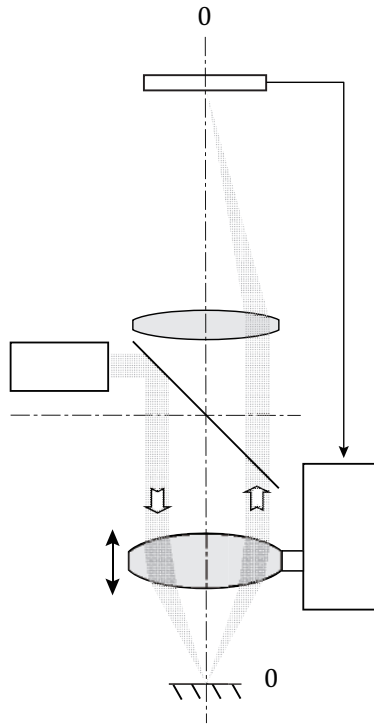

**a) In-focus**

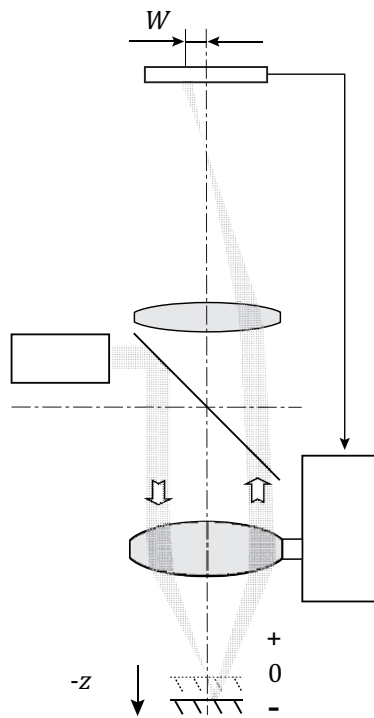

**b) Defocus**

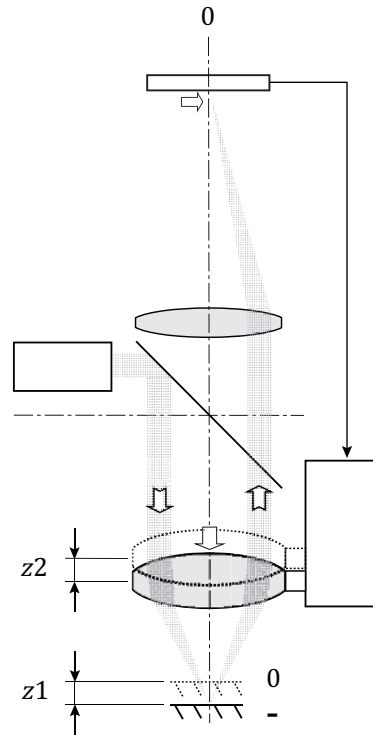

**c) Refocus**

**Figure A.2 — Principle of a typical point autofocus operation**

## Annex B (informative)

### Spot size and focal shift

The spot size not only determines the lateral resolution but also provides the focal shift parameter for surface measurement. When a parallel beam with a uniform intensity distribution enters from the back of the objective, the spot size ( $W_{\text{spot}}$ ) at its focal plane is generally given by:

$$W_{\text{spot}} = \frac{1,22\lambda}{A_N}$$

where

$\lambda$  is wavelength of the light source

$A_N$  is the numerical aperture

However, in the case of a light source with a Gaussian intensity distribution, such as a laser, the spot size is expressed as a diameter, where the intensity is a specified fraction of the maximum intensity. A commonly used fraction is  $1/e^2$  ( $\approx 13,5$  %) of the maximum intensity ([Figure B.1](#)). The associated spot size is given by

$$W_{\text{spot}} = \frac{0,64\lambda}{A_N}$$

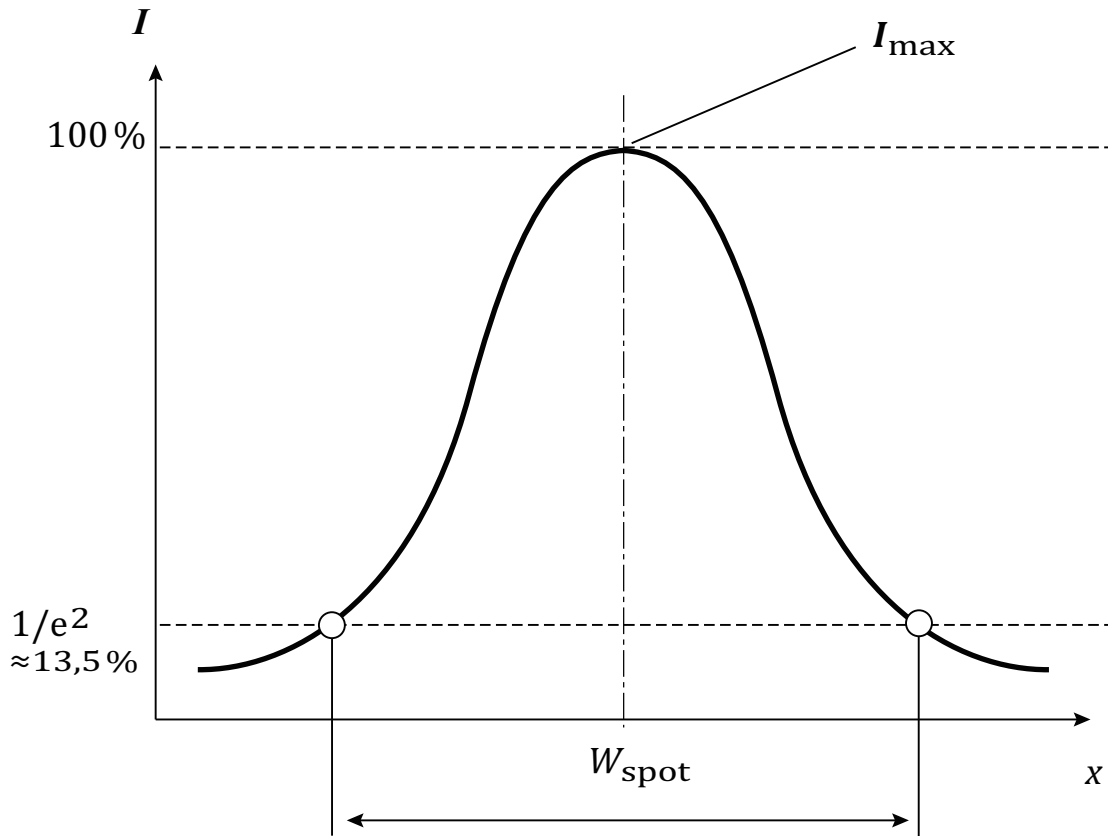

**Figure B.1 — Spot size**

[Figure B.2](#) shows an example of focal shift factors caused by different spot sizes.

[Figure B.2 a\)](#) shows a large spot image on the autofocus sensor resulting from reflection of the incident laser beam from an irregular workpiece surface. In this case the reflecting angle of ray (A) at the peak of the convex workpiece surface is less than the half aperture angle ( $\alpha_1$ ) and forms the image on the autofocus sensor that results in a bright area (A'). Conversely, the reflecting angle of ray (B) on the slope of the convex workpiece surface is greater than  $\alpha_1$ , which causes ray (B) to miss the objective and thus form no image on the autofocus sensor resulting in the dark area (B'). This is how uneven optical intensity can occur within the spot area on the autofocus sensor. When the autofocus sensor detects the geometrical centre of the spot area, the focus position shifts to  $\Delta E_1$ . This effect is a source of measurement error.

The half aperture angle ( $\alpha_2$ ) in the optical system in [Figure B.2 b\)](#) is greater than  $\alpha_1$  in [Figure B.2 a\)](#). Therefore, the autofocus sensor detects the ray on the slope of the convex workpiece surface, resulting in a smaller dark area and less variation of optical intensity in the spot area. In addition, a smaller spot size generates a smaller focus position shift,  $\Delta E_2$ .



## Annex C (informative)

### Beam offset direction and maximum acceptable local slope

The maximum acceptable local surface slope that can be measured with a point autofocus sensor varies with the laser beam offset direction. [Figure C.1](#) shows the laser beam path offset along the  $y$  coordinate direction. The maximum acceptable local slope angles parallel to the offset direction are  $A_1$  and  $A_2$  [[Figure C.1](#), a)]. The maximum acceptable local slope angle perpendicular to the offset direction is  $A_3$  [[Figure C.1](#), b)]. The maximum acceptable local slope angles  $A_1$ ,  $A_2$  and  $A_3$  are given by

$$A_1 < a$$

$$A_2 < \frac{\left( \alpha + \frac{b}{2} - a \right)}{2}$$

$$A_3 < \frac{\alpha}{2} + \frac{b}{4}$$

NOTE Greater slope angles are measurable if the surface roughness produces appreciable diffusely scattered light (see ISO 25178-602:2010, 3.4.14).

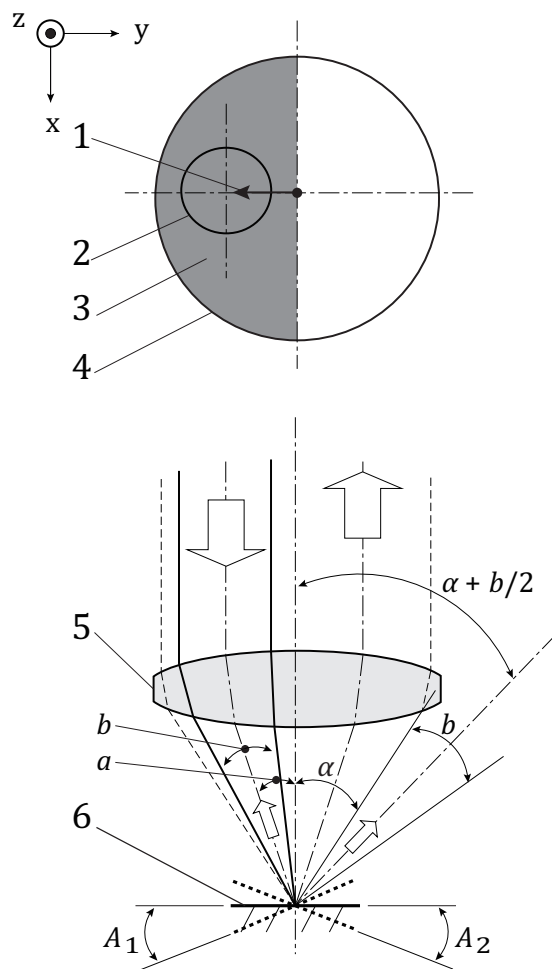

**a) Parallel to offsite direction**



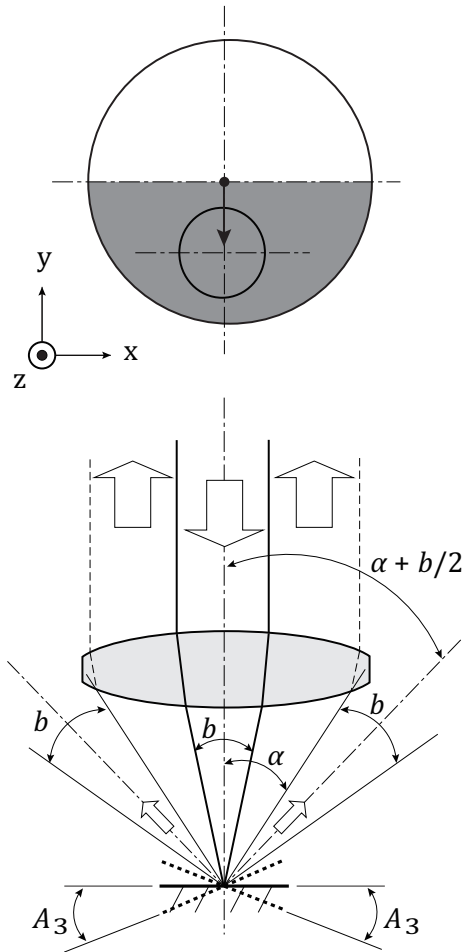

**b) Perpendicular to offset direction**

**Key**

- 1 offset direction
- 2 light beam
- 3 offset area
- 4 aperture
- 5 objective
- 6 plane mirror
- $a$  angle of incidence
- $b$  collection angle
- $\alpha$  half aperture angle

**Figure C.1 — Maximum acceptable local slope depends on offset direction**

## Annex D (informative)

### Features of an areal surface texture measuring instrument

#### D.1 General

Surface texture measuring instruments enable the assessment of quantities in  $x$ ,  $y$  and  $z$  from which areal surface texture parameters are calculated (see [Figure D.1](#)).

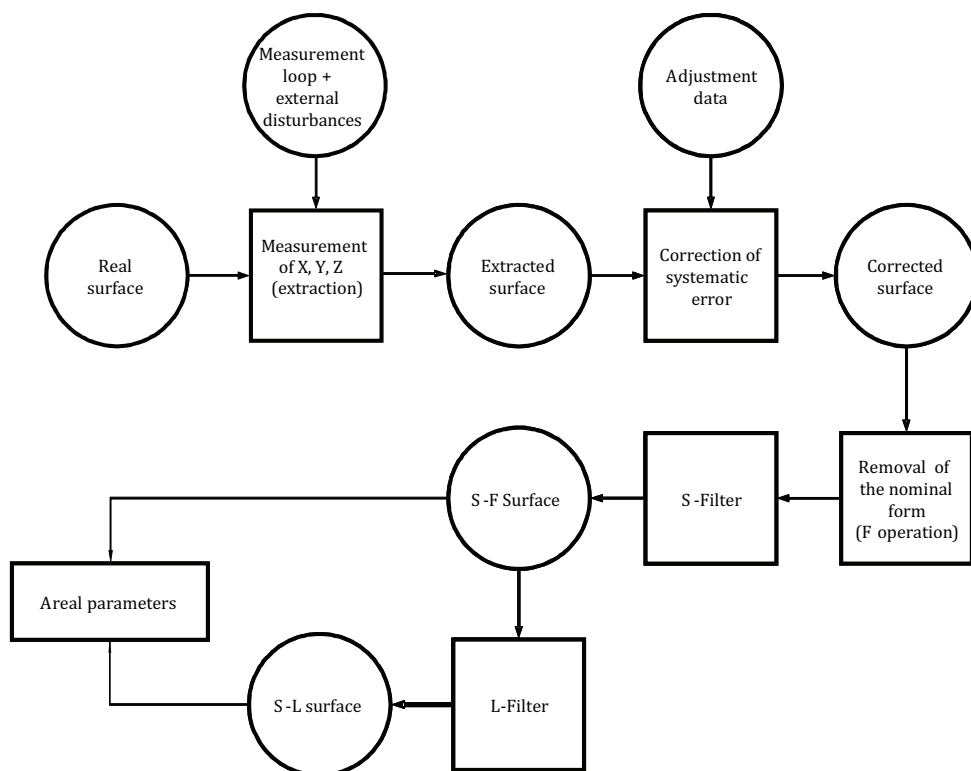

**Figure D.1 — Typical measurement method applied to an areal surface texture measuring instrument**

Quantities in  $x$  and  $y$  characterize the lateral position of the measured point. The quantity  $z$  characterizes the height of the measured point.

The knowledge of these three quantities allows the calculation of various areal surface texture parameters.

#### D.2 Point autofocus areal surface texture measuring instrument

An areal surface texture measuring instrument is composed of a lateral scanning system and a probing system.

A point autofocus probe areal surface measuring instrument uses a non-contact probing system which is based on the point autofocus principle for determining surface heights.

This type of instrument is also able to perform profile measurements.

The range of height measurement is determined by the movable range of the autofocus positioning mechanism and the working distance of the objective. A typical measuring range is from several millimetres to several tens of millimetres.

### D.3 Measurement process

A typical areal surface texture measuring instrument uses the following measurement process:

- a) the probing system performs profile acquisition through continuous measurement along the  $x$ -axis over a length  $l_x$ ;
- b) after the profile has been measured, the probing system returns to its starting position (see Note below);
- c) the perpendicular drive unit along the  $y$ -axis steps by one sampling interval distance along the  $y$ -axis;
- d) these operations are repeated until the measurement is completed;
- e) the raw surface is then obtained. It contains  $n$  profiles separated from each other by the  $y$  sampling interval, each profile containing  $m$  points separated by the  $x$  sampling interval.

**NOTE** It is also possible to perform the measurement without returning to the starting position after each profile. The next profile may be scanned in the opposite direction from that of the previous scan. In this case, it is recommended to check that the repositioning hysteresis is compatible with the intended measurement uncertainty. Nevertheless, a typical probing system is generally designed for measuring in only one direction.

Recommended values for  $m$ ,  $n$ ,  $l_x$  and  $l_y$  are found in ISO 25178-3.

## Annex E (informative)

### Others: Non-measured point (autofocus error)

Each time the sensor is not able to assess the z position of a point on the surface, the point is marked as an “autofocus error” (i.e. no information is provided for this point).

An autofocus error point is usually generated when the point autofocus system cannot identify any spots on the autofocus sensor, generally due to one of the conditions given in [Table E.1](#).

**Table E.1 — Possible explanations for why there can be non-measured points**

<b>Autofocus error</b>	<b>Condition</b>	<b>Cause</b>	<b>Solution</b>
Dim	Insufficient reflected optical intensity	1. Low reflection coefficient for the workpiece surface 2. High slope angle 3. Sudden height transition 4. No workpiece	1. Increase light source power 2. None 3. Extend the autofocus range 4. None
Hunting	Autofocus mechanism oscillates near the focus position	1. Servo-gain of the autofocus mechanism is set too high 2. The phase of the secondary reflected ray detected is the reverse of the primary ray	1. Lower servo-gain 2. Avoid detection of the secondary reflected ray
Shadowing	The dark area where the laser beam does not fall	Dead angle	None

NOTE Non-measured points can be reconstructed by an interpolation technique.

## Annex F (informative)

### Relation to the GPS matrix

For full details about the GPS matrix model, see ISO/TR 14638.

The ISO/GPS Masterplan given in ISO/TR 14638 gives an overview of the ISO/GPS system of which this standard is a part. The fundamental rules of ISO/GPS given in ISO 8015 apply to this standard and the default decision rules given in ISO 14253-1 apply to specifications made in accordance with this standard, unless otherwise indicated.

#### F.1 Information about this part of ISO 25178 and its use

This part of ISO 25178 gives the metrological characteristics of point autofocus profiling areal surface texture instruments.

#### F.2 Position in the GPS matrix model

This part of ISO 25178 is a general GPS standard, which influences chain link 5 of the chain of standards on roughness profile, waviness profile, primary profile and areal surface texture in the GPS matrix structure, as illustrated in [Figure F.1](#).

Global GPS standards	
<b>Fundamental GPS standards</b>	<b>General GPS matrix</b>
	Chain link number
	Size
	Distance
	Radius
	Angle
	Form of line independent of datum
	Form of line dependent of datum
	Form of surface independent of datum
	Form of surface dependent of datum
	Orientation
	Location
	Circular run-out
	Total run-out
	Datums
	Roughness profile
	Waviness profile
	Primary profile
	Surface imperfections
	Edges
Areal surface texture	

**Figure F.1 — Position in the GPS-Matrix model**

### F.3 Related standards

The related international standards are those of the chains of standards indicated in [Figure F.1](#).

## Bibliography

- [1] ISO/IEC Guide 99:2007, *International vocabulary of metrology — Basic and general concepts and associated terms (VIM)*
- [2] WYANT J.C., & SCHMIT J. Large Field of View, High Spatial Resolution, Surface Measurements. *Int. J. Mach. Tools Manuf.* 1998, **38** (5-6) pp. 691–698
- [3] ISO/TR 14638:1995, *Geometrical product specification (GPS) — Masterplan*
- [4] ISO 14660-1:1999<sup>1)</sup>, *Geometrical Product Specifications (GPS) — Geometrical features — Part 1: General terms and definitions*
- [5] MIURA K., OKADA M., TAMAKI J. Three-Dimensional Measurement of Wheel Surface Topography with a Laser Beam Probe. *Advances in Abrasive Technology.* 2000, **III** pp. 303–308
- [6] MIURA K., & OKADA M. *Measurement and evaluation of surface texture with optical contact probe.* Ultra precision process and mass production technology of a micro lens (array). pp.200-204 Apr.2003
- [7] MIURA K. *2D and 3D surface measurement with a Laser Probe.* Diffractive optics technical guide. pp.162-173 2004
- [8] MIURA K. *Roughness Measurement by optical probes.* Japan Society for Precision engineering The 303rd work shop text (2004)
- [9] FUKATSU H., & YANAGI K. Development of an optical stylus displacement sensor for surface profiling instruments. *Microsyst. Technol.* 2005, **11** pp. 582–589
- [10] BRODMANN R., & SMILGA W. In-process optical metrology for precision machining. *Proc. SPIE.* 1987, **802** p. 165
- [11] KUANG-CHAO FAN. Chih-Liang Chu and Jong-I Mou: *Development of a low-cost autofocusing probe for profile measurement.* *Meas. Sci. Technol.* 2001, **12** p. 2137
- [12] YANG C., PU Z., ZHAO H. Diffraction analysis and evaluation of a focus-error detection scheme for an optical profilometer. *Proc. SPIE.* 2000, **4221** p. 180
- [13] RM600, *A new approach to surface measurement (Product information)*, Optische Werke G. Rodenstock (1991)
- [14] UB16, *Precision optical length measurement system (Product information)*, Ulrich Breitmeier Messtechnik GmbH (1991)
- [15] LEACH R.K. *Fundamental principles of engineering nanometrology.* Chapter 6. Elsevier, Amsterdam, 2009

---

1) Withdrawn.







# British Standards Institution (BSI)

BSI is the national body responsible for preparing British Standards and other standards-related publications, information and services.

BSI is incorporated by Royal Charter. British Standards and other standardization products are published by BSI Standards Limited.

## About us

We bring together business, industry, government, consumers, innovators and others to shape their combined experience and expertise into standards-based solutions.

The knowledge embodied in our standards has been carefully assembled in a dependable format and refined through our open consultation process. Organizations of all sizes and across all sectors choose standards to help them achieve their goals.

## Information on standards

We can provide you with the knowledge that your organization needs to succeed. Find out more about British Standards by visiting our website at [bsigroup.com/standards](http://bsigroup.com/standards) or contacting our Customer Services team or Knowledge Centre.

## Buying standards

You can buy and download PDF versions of BSI publications, including British and adopted European and international standards, through our website at [bsigroup.com/shop](http://bsigroup.com/shop), where hard copies can also be purchased.

If you need international and foreign standards from other Standards Development Organizations, hard copies can be ordered from our Customer Services team.

## Subscriptions

Our range of subscription services are designed to make using standards easier for you. For further information on our subscription products go to [bsigroup.com/subscriptions](http://bsigroup.com/subscriptions).

With **British Standards Online (BSOL)** you'll have instant access to over 55,000 British and adopted European and international standards from your desktop. It's available 24/7 and is refreshed daily so you'll always be up to date.

You can keep in touch with standards developments and receive substantial discounts on the purchase price of standards, both in single copy and subscription format, by becoming a **BSI Subscribing Member**.

**PLUS** is an updating service exclusive to BSI Subscribing Members. You will automatically receive the latest hard copy of your standards when they're revised or replaced.

To find out more about becoming a BSI Subscribing Member and the benefits of membership, please visit [bsigroup.com/shop](http://bsigroup.com/shop).

With a **Multi-User Network Licence (MUNL)** you are able to host standards publications on your intranet. Licences can cover as few or as many users as you wish. With updates supplied as soon as they're available, you can be sure your documentation is current. For further information, email [bsmusales@bsigroup.com](mailto:bsmusales@bsigroup.com).

## BSI Group Headquarters

389 Chiswick High Road London W4 4AL UK

## Revisions

Our British Standards and other publications are updated by amendment or revision.

We continually improve the quality of our products and services to benefit your business. If you find an inaccuracy or ambiguity within a British Standard or other BSI publication please inform the Knowledge Centre.

## Copyright

All the data, software and documentation set out in all British Standards and other BSI publications are the property of and copyrighted by BSI, or some person or entity that owns copyright in the information used (such as the international standardization bodies) and has formally licensed such information to BSI for commercial publication and use. Except as permitted under the Copyright, Designs and Patents Act 1988 no extract may be reproduced, stored in a retrieval system or transmitted in any form or by any means – electronic, photocopying, recording or otherwise – without prior written permission from BSI. Details and advice can be obtained from the Copyright & Licensing Department.

## Useful Contacts:

### Customer Services

**Tel:** +44 845 086 9001

**Email (orders):** [orders@bsigroup.com](mailto:orders@bsigroup.com)

**Email (enquiries):** [cservices@bsigroup.com](mailto:cservices@bsigroup.com)

### Subscriptions

**Tel:** +44 845 086 9001

**Email:** [subscriptions@bsigroup.com](mailto:subscriptions@bsigroup.com)

### Knowledge Centre

**Tel:** +44 20 8996 7004

**Email:** [knowledgecentre@bsigroup.com](mailto:knowledgecentre@bsigroup.com)

### Copyright & Licensing

**Tel:** +44 20 8996 7070

**Email:** [copyright@bsigroup.com](mailto:copyright@bsigroup.com)



...making excellence a habit.™