

BS EN ISO 24234:2015



BSI Standards Publication

Dentistry — Dental amalgam

bsi.

...making excellence a habit.™

National foreword

This British Standard is the UK implementation of EN ISO 24234:2015. It supersedes BS EN ISO 24234:2004+A1:2011 which is withdrawn.

The UK participation in its preparation was entrusted to Technical Committee CH/106/1, Dental restorative and orthodontic materials.

A list of organizations represented on this committee can be obtained on request to its secretary.

This publication does not purport to include all the necessary provisions of a contract. Users are responsible for its correct application.

© The British Standards Institution 2015.
Published by BSI Standards Limited 2015

ISBN 978 0 580 79885 6

ICS 11.060.10

Compliance with a British Standard cannot confer immunity from legal obligations.

This British Standard was published under the authority of the Standards Policy and Strategy Committee on 31 May 2015.

Amendments/corrigenda issued since publication

Date	Text affected
------	---------------

English Version

Dentistry - Dental amalgam (ISO 24234:2015)Médecine bucco-dentaire - Amalgame dentaire (ISO
24234:2015)

Zahnheilkunde - Dentale Amalgame (ISO 24234:2015)

This European Standard was approved by CEN on 3 January 2015.

CEN members are bound to comply with the CEN/CENELEC Internal Regulations which stipulate the conditions for giving this European Standard the status of a national standard without any alteration. Up-to-date lists and bibliographical references concerning such national standards may be obtained on application to the CEN-CENELEC Management Centre or to any CEN member.

This European Standard exists in three official versions (English, French, German). A version in any other language made by translation under the responsibility of a CEN member into its own language and notified to the CEN-CENELEC Management Centre has the same status as the official versions.

CEN members are the national standards bodies of Austria, Belgium, Bulgaria, Croatia, Cyprus, Czech Republic, Denmark, Estonia, Finland, Former Yugoslav Republic of Macedonia, France, Germany, Greece, Hungary, Iceland, Ireland, Italy, Latvia, Lithuania, Luxembourg, Malta, Netherlands, Norway, Poland, Portugal, Romania, Slovakia, Slovenia, Spain, Sweden, Switzerland, Turkey and United Kingdom.



EUROPEAN COMMITTEE FOR STANDARDIZATION
COMITÉ EUROPÉEN DE NORMALISATION
EUROPÄISCHES KOMITEE FÜR NORMUNG

CEN-CENELEC Management Centre: Avenue Marnix 17, B-1000 Brussels

Foreword

This document (EN ISO 24234:2015) has been prepared by Technical Committee ISO/TC 106 "Dentistry" in collaboration with Technical Committee CEN/TC 55 "Dentistry" the secretariat of which is held by DIN.

This European Standard shall be given the status of a national standard, either by publication of an identical text or by endorsement, at the latest by November 2015, and conflicting national standards shall be withdrawn at the latest by November 2015.

Attention is drawn to the possibility that some of the elements of this document may be the subject of patent rights. CEN [and/or CENELEC] shall not be held responsible for identifying any or all such patent rights.

This document supersedes EN ISO 24234:2004.

According to the CEN-CENELEC Internal Regulations, the national standards organizations of the following countries are bound to implement this European Standard: Austria, Belgium, Bulgaria, Croatia, Cyprus, Czech Republic, Denmark, Estonia, Finland, Former Yugoslav Republic of Macedonia, France, Germany, Greece, Hungary, Iceland, Ireland, Italy, Latvia, Lithuania, Luxembourg, Malta, Netherlands, Norway, Poland, Portugal, Romania, Slovakia, Slovenia, Spain, Sweden, Switzerland, Turkey and the United Kingdom.

Endorsement notice

The text of ISO 24234:2015 has been approved by CEN as EN ISO 24234:2015 without any modification.

Contents

Page

Foreword	iv
Introduction	v
1 Scope	1
2 Normative references	1
3 Terms and definitions	2
4 Requirements	2
4.1 Chemical composition and purity of the dental amalgam alloy.....	2
4.2 Foreign material and large particles in the dental amalgam alloy powder.....	3
4.3 Accuracy and variability of pre-proportioned masses.....	3
4.4 Properties of the dental amalgam.....	4
4.5 Appearance of the mixed dental amalgam before setting.....	4
5 Sampling	4
6 Test methods	5
6.1 Chemical composition and purity of the dental amalgam alloy.....	5
6.2 Foreign material and large particles in the dental amalgam alloy powder.....	5
6.3 Determination of the accuracy and variability of pre-proportioned masses.....	5
6.4 Preparation of test-pieces to determine compliance with the requirements for creep, dimensional change during hardening, and compressive strength.....	7
6.5 Determination of creep.....	12
6.6 Determination of dimensional change during hardening.....	12
6.7 Determination of compressive strength.....	13
6.8 Appearance of the mixed dental amalgam before setting.....	14
7 Marking, labelling, and packaging	15
7.1 Packaging.....	15
7.2 Marking.....	15
7.3 Manufacturer's instructions.....	17
Bibliography	19

Foreword

ISO (the International Organization for Standardization) is a worldwide federation of national standards bodies (ISO member bodies). The work of preparing International Standards is normally carried out through ISO technical committees. Each member body interested in a subject for which a technical committee has been established has the right to be represented on that committee. International organizations, governmental and non-governmental, in liaison with ISO, also take part in the work. ISO collaborates closely with the International Electrotechnical Commission (IEC) on all matters of electrotechnical standardization.

The procedures used to develop this document and those intended for its further maintenance are described in the ISO/IEC Directives, Part 1. In particular the different approval criteria needed for the different types of ISO documents should be noted. This document was drafted in accordance with the editorial rules of the ISO/IEC Directives, Part 2 (see www.iso.org/directives).

Attention is drawn to the possibility that some of the elements of this document may be the subject of patent rights. ISO shall not be held responsible for identifying any or all such patent rights. Details of any patent rights identified during the development of the document will be in the Introduction and/or on the ISO list of patent declarations received (see www.iso.org/patents).

Any trade name used in this document is information given for the convenience of users and does not constitute an endorsement.

For an explanation on the meaning of ISO specific terms and expressions related to conformity assessment, as well as information about ISO's adherence to the WTO principles in the Technical Barriers to Trade (TBT) see the following URL: Foreword - Supplementary information

The committee responsible for this document is ISO/TC 106, *Dentistry*, Subcommittee SC 1, *Filling and Restorative Materials*.

This second edition cancels and replaces the first edition (ISO 24234:2004), which has been technically revised. It also incorporates the amendment ISO 24234:2004/Amd, 1. The following changes have been made.

- The title of this International Standard has been changed to reflect the content and requirements more accurately.
- The supply of dental mercury in units of greater mass (bulk dental mercury) is no longer within the scope of this International Standard. Through this restriction on the supply of dental mercury for a product to comply with this International Standard (introduced by ISO/TC 106 SC1), a general concern about the environmental impact from the sale of mercury in bulk volumes (for all applications) is addressed.
- As a consequence of the removal of dental mercury supplied in bulk quantities from the scope of this International Standard, requirements for freedom from contamination (by water, oil and foreign bodies) and free pouring of dental mercury are no longer present in this International Standard.
- The values for the requirements on the dimensional change during hardening and the compressive strength at 1 h and 24 h have been revised. "Permitted dimensional change during hardening" is changed from (- 0,10 to +0,20) % to (-0,10 to +0,15) %. Furthermore, the "Minimum compressive strength at 1h" is increased from 80 to 100 MPa, and the "Minimum compressive strength at 24 h" is increased from 300 to 350 MPa.
- Provisions for packaging and marking have been revised.
- Markings required for mercury safety warnings and precautions have been revised.
- Normative annexes on procedures for corrosion testing have been removed from this International Standard and are now contained in a new International Technical Specification, ISO/TS 17988: *Dentistry — Corrosion test methods for dental amalgam*.

Introduction

Dental amalgam alloy and dental mercury are the essential and only components of dental amalgam restorative material. This International Standard specifies the requirements and the test methods for dental amalgam alloy that is suitable for the preparation of dental amalgam, together with those for the set dental amalgam and the requirements for packaging and marking (including those for dental mercury), of which this International Standard is the second edition.

Specific qualitative and quantitative test methods for demonstrating freedom from unacceptable biological hazard are not included in this International Standard but it is recommended that, for the assessment of possible biological hazards, reference should be made to ISO 10993 and ISO 7405.

To enhance the safety of dentists and support staff, and minimize the consequence that might result from the accidental damage to containers during shipping, the scope is limited solely to dental mercury that is supplied pre-capsulated or in pre-dosed sachets. Both are limited to a mass sufficient for one mix.

Safety precautions relating to marking, labelling, and packaging have been strengthened in this revision.

Restricting the scope to dental amalgam alloys with copper contents above 12 % by mass (i.e. “high copper” dental amalgam alloy) was considered, because it is reported that restorations made with such alloys, as a group, have a better long term survival rate than those made with traditional alloys (i.e. “low copper” dental amalgam alloy). This was rejected since there are a few products with a low copper content that produce restorations that are as durable as those produced using some of the high copper products. (Factors other than the percentage of copper are important.) Also, it was felt that excluding products from compliance should not be done by a change to the composition requirement; it should be on the basis of a revision to the requirements for the properties that determine performance.

Inclusion of a requirement for corrosion resistance was considered. However, it was agreed that the data available were insufficient to set a corrosion requirement in this edition of this International Standard. A requirement for the corrosion resistance will be set and incorporated at the earliest possible date. It is recommended that, in assessing corrosion resistance of a dental amalgam product (relative to other dental amalgam products) reference should be made to ISO/TS 17988.

In the first edition of this International Standard (and before that in ISO 1559) a compression strength test was used to determine the resistance to fracture of dental amalgam. Such a test, with a compressive strength requirement, continues to be used in this edition. However, the Working Group recognizes that dental amalgam, is in effect, a brittle material and it is evaluating a suitable test procedure that produces tensile forces to initiate fracture in a way that replicates the clinical process. At this time, the work has not reached the point at which this test (with a requirement) can be included in this revision of the International Standard. When evaluation is completed, consideration will be given to adding a requirement for fracture resistance that utilizes this test. This will be in the form of a Technical Amendment.

Requirements and test methods for the capsules used for pre-capsulated products are contained in ISO 13897.

Dentistry — Dental amalgam

1 Scope

This International Standard specifies the requirements and test methods for dental amalgam alloys that are suitable for the preparation of dental amalgam, together with the requirements and test methods for that dental amalgam and the requirements for packaging and marking (including those for dental mercury).

It is applicable to dental amalgam alloys supplied in the form of a free-flowing powder in bulk, or a powder compressed to form a tablet, or a powder in a capsule (i.e. pre-capsulated).

With respect to dental mercury, the scope is limited solely to dental mercury which is supplied pre-capsulated or in pre-dosed sachets. Both are limited to a mass sufficient for one mix. The mass of dental mercury in one capsule or sachet shall be sufficient to produce a homogeneous plastic mix, appropriate for a small or medium sized restoration in a single tooth. This International Standard is not applicable to mercury supplied in masses greater than this in a single primary container (i.e. dental mercury in bulk). Dental mercury supplied in bulk volumes will not conform to this International Standard.

This International Standard does not exclude the supply of dental amalgam alloy or dental mercury separately.

This International Standard is not applicable to metallic materials in which an alloy powder reacts with an alloy that is liquid at ambient temperature to produce a solid metallic material intended for dental restoration.

NOTE Dental mercury is at least 99,99 % pure, and as such, it is a metallic element of high commercial purity, and not an alloy

2 Normative references

The following documents, in whole or in part, are normatively referenced in this document and are indispensable for its application. For dated references, only the edition cited applies. For undated references, the latest edition of the referenced document (including any amendments) applies.

ISO 286-2, *Geometrical product specifications (GPS) — ISO code system for tolerances on linear sizes — Part 2: Tables of standard tolerance classes and limit deviations for holes and shafts*

ISO 1942, *Dentistry — Vocabulary*

ISO 3310-1, *Test sieves — Technical requirements and testing — Part 1: Test sieves of metal wire cloth*

ISO 3864-2, *Graphical symbols — Safety colours and safety signs — Part 2: Design principles for product safety labels*

ISO 6344-1, *Coated abrasives — Grain size analysis — Part 1: Grain size distribution test*

ISO 7488, *Dental amalgamators*

ISO 13565-2, *Geometrical Product Specifications (GPS) — Surface texture: Profile method; Surfaces having stratified functional properties — Part 2: Height characterization using the linear material ratio curve*

ISO 13897, *Dentistry — Amalgam capsules*

ISO 15223-1, *Medical devices — Symbols to be used with medical device labels, labelling and information to be supplied — Part 1: General requirements*

Globally Harmonized System of Classification and Labelling of Chemicals (GHS). United Nations, New York and Geneva, 5th Edition, 2010, ISBN 92-1-116840-6

UN Recommendations on the Transport of Dangerous Goods, Model Regulations. United Nations, New York and Geneva, 18th Edition 2013. ISBN 978-9211931466

3 Terms and definitions

For the purposes of this document, the terms and definitions given in ISO 1942 and the following apply.

3.1 dental amalgam alloy

alloy in fine particles, composed mainly of silver, tin, and copper, which, when mixed with dental mercury, produces a dental amalgam

3.2 dental mercury

mercury supplied for use in the preparation of dental amalgam

Note 1 to entry: Dental mercury complying with the scope of this International Standard is supplied either pre-capsulated (3.3) or in a pre-dosed sachet (3.5), with a mass that is considered suitable for a single small or medium size restoration in a single tooth.

3.3 pre-capsulated product

product supplied in a sealed capsule that contains measured amounts of dental amalgam alloy powder and dental mercury with masses that are appropriate for the production of a mass of dental amalgam that is considered to be suitable for a single small or medium sized restoration in a single tooth

Note 1 to entry: The dental amalgam alloy powder and dental mercury are separated by a barrier that is broken immediately prior to mixing to allow their contact. The capsule remains sealed until mixing has been completed.

3.4 dental amalgam alloy tablet

dental amalgam alloy powder that has been compressed to form a single entity for the purpose of providing a pre-dosed quantity of the alloy that when mixed with an appropriate mass of dental mercury, produces a mass of dental amalgam that is considered to be suitable for a single small or medium sized restoration in a single tooth

Note 1 to entry: During mixing, the tablet is intended to break apart, forming a fine powder.

3.5 dental mercury sachet

measured quantity of dental mercury supplied in a sachet (for use in a reusable mixing capsule) in a mass that, when mixed with an appropriate mass of dental amalgam alloy, produces a mass of dental amalgam that is considered to be suitable for a single small or medium sized restoration in a single tooth

Note 1 to entry: The sachet is intended to rupture during mixing to allow the dental mercury to come into contact with the dental amalgam alloy.

4 Requirements

4.1 Chemical composition and purity of the dental amalgam alloy

The manufacturer shall declare every element that is present in a concentration greater than, or equal to 0,1 % (mass fraction). All alloying elements present in concentrations greater than 0,5 % (mass fraction) shall be given by name with mass fraction values rounded to the nearest whole percentage point. Alloying elements that are present in concentrations between 0,1 % and 0,5 % (mass fraction) shall be named without a percentage value.

Test in accordance with [6.1](#).

The chemical composition shall comply with [Table 1](#).

The total for other elements present in concentrations greater than 0,01 % (mass fraction) but below 0,1 % (mass fraction) that are not declared as alloying elements, shall not exceed 0,1 % (mass fraction).

Table 1 — Requirements for chemical composition of the dental amalgam alloy

Element	Mass fraction %
silver	≥40
tin	≤32
copper	≤30
indium	≤5
palladium	≤1
platinum	≤1
zinc	≤2
mercury	≤3

4.2 Foreign material and large particles in the dental amalgam alloy powder

This requirement applies to all products with the exception of products in which dental mercury sachets alone are supplied.

When tested in accordance with [6.2](#), no more than five particles of foreign material shall be found on the sieve.

The mass of alloy particles that remain on the sieve shall not exceed 0,1 % (mass fraction) of the sample used for this test.

4.3 Accuracy and variability of pre-proportioned masses

4.3.1 For dental mercury sachet products

The arithmetic mean of the mass of the dental mercury in the sachet shall be within ±2,0 % of the manufacturer's stated mass, when tested in accordance with [6.3.1](#).

The coefficient of variation of the mass of the dental mercury in the sachets shall not exceed 1,5 %, when tested in accordance with [6.3.1](#).

4.3.2 For pre-capsulated products

The arithmetic means of the masses of both dental amalgam alloy and dental mercury in the capsule shall be within ±2,0 % of the manufacturer's stated masses, when tested in accordance with [6.3.2](#).

The coefficients of variation of the masses of the dental amalgam alloy and the dental mercury in the capsules shall not exceed 1,5 %, when tested in accordance with [6.3.2](#).

4.3.3 For dental amalgam alloy tablet products

The arithmetic mean of the mass of the dental amalgam alloy tablet shall be within ±2,0 % of the manufacturer's stated mass, when tested in accordance with [6.3.3](#).

The coefficient of variation of the mass of the dental amalgam alloy tablets shall not exceed 1,5 %, when tested in accordance with [6.3.3](#).

4.4 Properties of the dental amalgam

This requirement applies to all products in which dental amalgam alloy is supplied.

Table 2 — Properties of the dental amalgam

Maximum creep	Permitted dimensional change during hardening	Minimum compressive strength at 1 h	Minimum compressive strength at 24 h
%	%	MPa	MPa
2,0	-0,10 to +0,15	100	350

4.4.1 Creep

When tested in accordance with 6.5, either three out of three, or four out of five test-pieces shall meet the requirement in Table 2.

4.4.2 Dimensional changes during hardening

When tested in accordance with 6.6, at least four out of five test-pieces shall meet the requirement in Table 2.

4.4.3 Compressive strength at 1 h

When tested in accordance with 6.7, at least four out of five test-pieces, or eight out of ten test-pieces shall meet the requirement in Table 2.

4.4.4 Compressive strength at 24 h

When tested in accordance with 6.7, at least four out of five test-pieces, or eight out of ten test-pieces shall meet the requirement in Table 2.

4.5 Appearance of the mixed dental amalgam before setting

This requirement applies to all products in which dental amalgam alloy is supplied.

When the dental amalgam alloy and dental mercury are mixed according to the manufacturer's instructions and tested in accordance with 6.8, the dental amalgam shall form a coherent plastic mass with a shiny surface before packing and remain a coherent plastic mass after packing.

5 Sampling

Procure containers of capsules (pre-capsulated products), or dental mercury sachets, or dental amalgam alloy powder, or dental amalgam alloy tablets of the same lot in packages that have been produced for retail.

For products supplied as free-flowing dental amalgam alloy powder or dental amalgam alloy tablets, at least 50 g of dental amalgam alloy is required.

For pre-capsulated products, the number of capsules required depends on the masses of dental amalgam alloy and dental mercury in each.

For dental mercury supplied in sachets, 25 sachets are required.

6 Test methods

6.1 Chemical composition and purity of the dental amalgam alloy

Use a recognized, instrumented analytical procedure that has adequate sensitivity to determine the composition of the dental amalgam alloy for the elements declared by the manufacturer in compliance with 4.1.

For other elements that are detected at mass fractions greater than 0,01 %, but are not alloying elements (declared as such by the manufacturer in compliance with 4.1), sum their mass fractions and report the sum as the mass fraction of other elements.

NOTE Inductively-coupled plasma (ICP) spectroscopy is an example of a suitable analytical procedure.

6.2 Foreign material and large particles in the dental amalgam alloy powder

For dental amalgam alloy supplied as a free-flowing powder in bulk, weigh a $(10,0 \pm 0,1)$ g sample to an accuracy of ± 1 mg and record (m_s).

For dental amalgam alloy supplied as tablets, place a tablet in a reusable capsule that complies with ISO 13897. Break the tablet in the capsule to its constituent powder particles by using an amalgamator (that complies with ISO 7488) at the machine setting and at one-half the time recommended by the dental amalgam alloy manufacturer for mixing the dental amalgam alloy and dental mercury in accordance with 7.3.1. If the manufacturer's recommendations include any other action to break-up the tablet (e.g. use of a pestle), incorporate this at the appropriate time. Repeat this using a sufficient number of tablets to obtain $(10,0 \pm 0,1)$ g of powder. Weigh this sample to an accuracy of ± 1 mg and record (m_s).

For pre-capsulated products, select and open a sufficient number of capsules to obtain a $(10,0 \pm 0,1)$ g sample of dental amalgam alloy powder. Weigh this sample to an accuracy of ± 1 mg and record (m_s).

Place the powder sample on a sieve of mesh size $150 \mu\text{m}$ that conforms to ISO 3310-1. Hold the sieve assembly (consisting of collecting pan, sieve, and cover) in one hand and tap it gently against the other hand at a rate of approximately twice a second for 120 s. Inspect the sieve at a magnification of $\times 10$ for any foreign material and remaining dental amalgam alloy particles. Record the number of foreign material particles.

Remove any foreign material and then transfer the dental amalgam alloy particles remaining on the sieve to a balance. Weigh to an accuracy of ± 1 mg and record (m_r). Calculate the mass fraction of the dental amalgam alloy that occurs in particles that have a size greater than $150 \mu\text{m}$, as follows:

$$w = \frac{m_r}{m_s} \times 100 \quad (\%) \quad (1)$$

where

m_r is the mass of amalgam alloy particles remaining on the sieve;

m_s is the mass of the powder sample;

w is the mass fraction of the dental amalgam alloy particles greater than $150 \mu\text{m}$ in size, expressed as a percentage.

6.3 Determination of the accuracy and variability of pre-proportioned masses

6.3.1 Dental mercury sachet products

Select 25 sachets at random.

Determine the mass of the dental mercury in each of these as follows.

Remove all dental mercury from one of these sachets and weigh this dental mercury and the empty sachet individually, to the nearest 1 mg.

Weigh the other 24 sachets individually, to the nearest 1 mg. Subtract the mass of the empty sachet to obtain the mass of dental mercury in each of these sachets.

Determine the arithmetic mean and standard deviation for the set of 25.

Calculate the coefficient of variation:

$$C_v = \frac{s}{\bar{x}} \times 100 \quad (\%) \quad (2)$$

where

s is the standard deviation;

\bar{x} is the arithmetic mean;

C_v is the coefficient of variation.

6.3.2 Pre-capsulated products

Select 25 capsules at random.

In order to separate the dental amalgam alloy powder from the dental mercury and prevent premature combination, several different capsule designs have been developed.

If the capsule contains the dental mercury in a sachet that can be removed from the capsule without rupturing the sachet, the procedure used for dental mercury sachets (given in [6.3.1](#)) can be used.

If this is not the case, use a technique appropriate to the capsule being tested that removes all the dental mercury (from each of the 25 capsules) that avoids contact between dental mercury and dental amalgam alloy powder. Similarly, use a technique appropriate to the capsule being tested that removes all the dental amalgam alloy powder (from each of the 25 capsules) that avoids contact between the dental amalgam alloy powder and the dental mercury.

Determine the masses of the dental amalgam alloy and dental mercury in each of 25 capsules. Weigh the dental amalgam alloy and the dental mercury separately, each to 1 mg. Record each value.

Determine the arithmetic means and the standard deviations for the masses of dental mercury and dental amalgam alloy powder.

Calculate the coefficients of variation for the dental amalgam alloy and dental mercury according to Formula (2).

NOTE It might be necessary to measure the masses of dental mercury and dental amalgam alloy in two different sets of 25 capsules.

6.3.3 Dental amalgam alloy tablet products

Weigh 25 tablets individually to the nearest 1 mg.

Determine the arithmetic mean and standard deviation for the mass of the tablet.

Calculate the coefficient of variation according to Formula (2).

6.4 Preparation of test-pieces to determine compliance with the requirements for creep, dimensional change during hardening, and compressive strength

6.4.1 Temperature

Prepare test-pieces at (23 ± 2) °C.

6.4.2 Mixing

Mix a mass of dental amalgam sufficient to make a cylindrical test-piece (8 ± 1) mm in length after packing into the die shown in [Figure 1](#).

For a dental amalgam alloy product supplied either as tablets or as a free-flowing powder in bulk, the ratio by mass of the dental amalgam alloy to the dental mercury should be that recommended by the manufacturer. Use a capsule (with a pestle, if needed) that complies with ISO 13897. Use any other mixing accessory that is required to conform to the recommendations given by the manufacturer in accordance with [7.3.1](#). Use a dental mercury sachet product that complies with this International Standard. If more than one mix is required to make the test-piece, produce these mixes simultaneously using equipment of the same type for each mix. However, if the last mix can be produced within the working time of the first mix, mixing these masses sequentially on a single piece of equipment is allowed.

For pre-capsulated products, use as many capsules as needed. Simultaneously, mix the contents of the capsules using the same number of amalgamators of the same brand and model, or sequentially mix the content of the capsules on a single amalgamator. (The latter is allowed, provided the mixing for the last capsule is completed before the end of the working time of the first.) If necessary, use only a portion of the dental amalgam mix from one of these capsules.

Use an amalgamator that complies with ISO 7488, and that is recommended for mixing the dental amalgam alloy product with dental mercury or mixing the pre-capsulated product. Use the amalgamator setting and mixing time that are recommended by the manufacturer of the dental amalgam alloy or pre-capsulated product (for the mass of dental amalgam alloy that is being mixed). (See [7.3.1](#).)

NOTE The mass of a 4 mm diameter amalgam cylinder 8 mm in length is approximately 1,2 g.

6.4.3 Apparatus for the preparation of test-pieces for determining creep, dimensional change during hardening, and compressive strength

6.4.3.1 General

Use the apparatus as shown in [Figures 1](#) to [5](#).

6.4.3.2 Materials and tolerances for construction of the apparatus

Make the holder, the spacers, and the cap of cold-rolled or stainless steel. Make the die and the plungers of hardened tool steel or hardened stainless steel. Hone the working surfaces of the die and the plungers to a core roughness depth (R_k) not greater than $6,3 \mu\text{m}$ when tested in accordance with ISO 13565-2. Set the limits of clearance between the die and the plungers at F7 and h7, respectively, in accordance with ISO 286-2.

6.4.3.3 Assembly of the apparatus

For production of creep and compressive strength test-pieces, assemble the holder, spacer no. 1 and spacer no. 2, the die and plunger no. 2 as shown in [Figure 1](#).

Particular measuring instruments used in the test for dimensional change during hardening (e.g. interferometers) might require an impression on the end surface of the test-piece that is produced by the cap that is shown in [Figure 5](#). For the production of test-pieces for the measurement of dimensional

change during hardening, include the cap in the assembly if this is appropriate for the measuring instrument that is to be used. In which case, position the cap on top of the plunger no. 2.

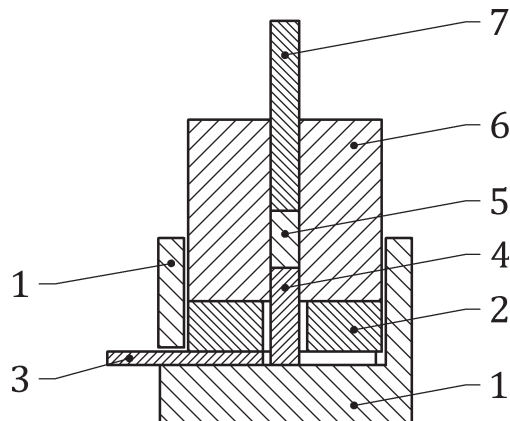

Key

- | | | | |
|---|---------------|---|---------------|
| 1 | holder | 5 | test-piece |
| 2 | spacer no. 1 | 6 | die |
| 3 | spacer no. 2 | 7 | plunger no. 1 |
| 4 | plunger no. 2 | | |

NOTE The dimensions for each of the components are given in [Figures 2 to 5](#) that follow.

Figure 1 — Vertical section through the apparatus for making dental amalgam test-pieces, showing the assembled apparatus with a test-piece in place

Dimensions in millimetres

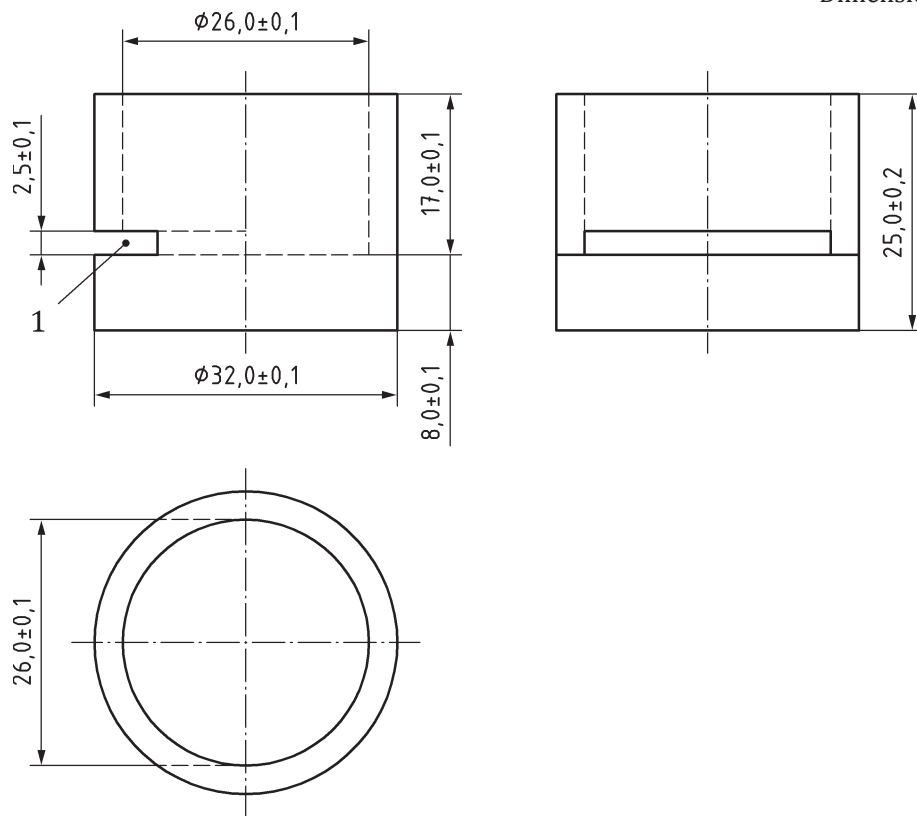

Key
 1 slot

Figure 2 — The holder

Dimensions in millimetres

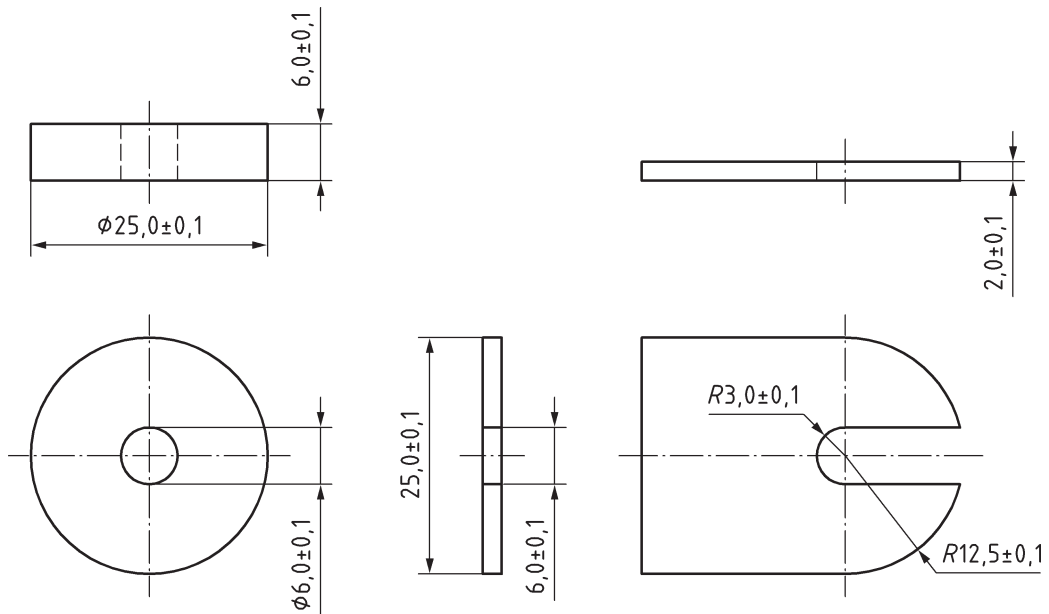
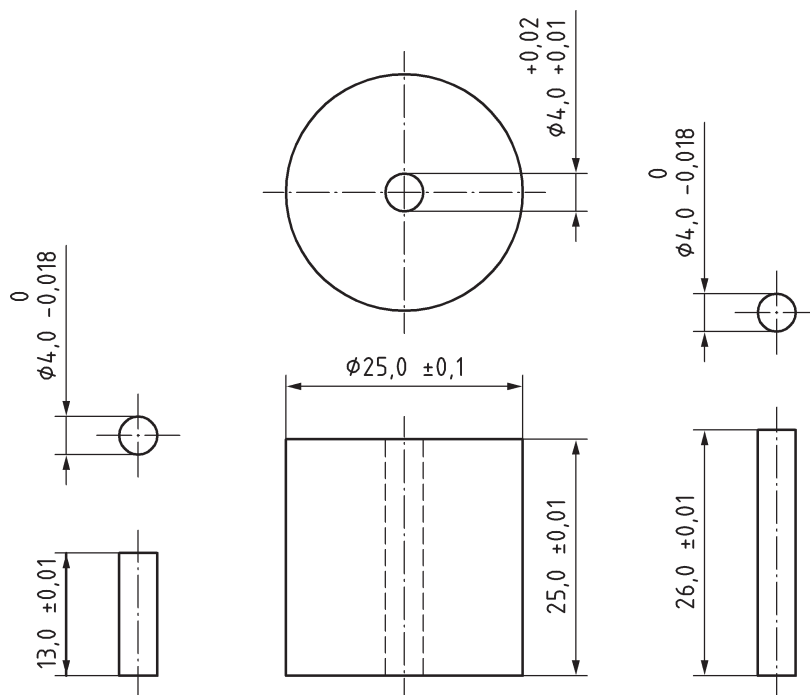

Figure 3 — Spacer no. 1 (left) and spacer no. 2 (right)

Dimensions in millimetres



NOTE 1 To assist the operator in judging whether the correct quantity of dental amalgam has been inserted into the die, for the test-piece to be within the permitted range for length [i.e. (8 ± 1) mm], circumferential datum lines can be scribed at 9 mm, 11 mm, and 13 mm from one end of plunger no. 1. This end (from which the distances to the scribed lines are measured) is to be in contact with the dental amalgam. Though such datum lines are not mandatory, their use is recommended.

NOTE 2 The diameters of the plungers are subject to a shaft (or in this case a plunger) clearance (with a tolerance) of h7 according to ISO 286-2. For a plunger that is nominally 4,000 mm in diameter, its diameter shall be between 0 μ m and 18 μ m less than 4,000 mm. Thus, the diameter of the plunger is to be between 3,982 mm and 4,000 mm.

NOTE 3 The diameter of the hole in the die is subject to a clearance (with a tolerance) of F7 according to ISO 286-2. For a hole that is nominally 4,000 mm in diameter, its diameter shall be between 10 μ m and 20 μ m more than 4,000 mm. Thus the diameter of the hole is to be between 4,010 mm and 4,020 mm.

Figure 4 — Plunger no. 2 (left), the die (centre), and plunger no. 1 (right)

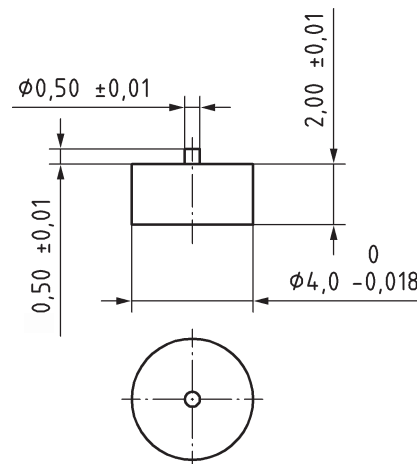

NOTE This cap is to be used in conjunction with the apparatus shown in [Figure 1](#) if the measuring instrument requires a small indentation at one end of the test-piece.

Figure 5 — Cap used for the production of test-pieces used for the measurement of dimensional change during hardening

6.4.4 Packing

Place the coherent mass of mixed dental amalgam on top of the die cavity and insert immediately with several thrusts of a hand instrument for amalgam packing that is slightly less than 4 mm in diameter. Do not express mercury during this insertion. Then, insert plunger no. 1 and proceed, following the schedule in [Table 3](#).

Table 3 — Schedule for the preparation of the test-pieces

Procedure	Time in seconds
	Time
End of mixing at	0
Insert the mixed mass into the die cavity, then plunger no. 1, and apply a force of (176 ± 13) N to produce a pressure of (14 ± 1) MPa at	30
Release the force and remove spacer no. 2 at	45
Reapply the force at	50
Re-release the force at	90
Carefully remove excess mercury and eject the test-piece at	120

After ejection, the test-piece shall not be trimmed.

Inspect the surfaces of the test-piece for any defects. Use visual inspection without magnification. Carry out this inspection at an illuminance of at least 1 000 lux and at a distance not exceeding 250 mm. A person making the inspection shall have nominally normal visual acuity. [Corrective (non-magnifying) untinted lenses can be worn.] If the test-piece is defective, replace it.

Transfer the test-piece to air maintained at (37 ± 1) °C.

NOTE 1 If plunger no. 1 has circumferential datum lines scribed on its cylindrical surface and the cap ([Figure 5](#)) is not present in the assembled apparatus, and the 13 mm datum line alone can be seen, the test-piece will have a length that is (8 ± 1) mm.

NOTE 2 If the cap ([Figure 5](#)) is present in the assembled apparatus and both 11 mm and 13 mm datum lines can be seen but the 9 mm line cannot, the test-piece will have a length that is (8 ± 1) mm.

6.5 Determination of creep

6.5.1 Preparation of the test-pieces

Prepare the test-pieces in accordance with [6.4](#).

Make five test-pieces.

Inspect the ends of each test-piece. In general, the ends of a test-piece will not have flash and will be perfectly flat and orthogonal to the cylinder axis, producing an acceptable test-piece. If necessary, remove any flash with a gentle rub on wet, coated abrasive that complies with microgrit size P1200, according to ISO 6344-1. Do not grind. After this, check that the ends are still flat and parallel.

NOTE Excessive abrasion can produce uneven removal, and as a consequence, the need to replace the test-piece.

Store these at (37 ± 1) °C for $(7,0 \pm 0,2)$ d. Prior to testing, measure the length of each test-piece and record it, to the nearest 0,01 mm, as the original length.

6.5.2 Procedure

Directly after measuring the original length, apply a stress of $(36,0 \pm 0,2)$ MPa normally and uniformly over the cylinder ends, continuously for 4 h at a temperature of $(37,0 \pm 0,5)$ °C. Record the change in length of the test-piece between $(1,00 \pm 0,05)$ h and $(4,0 \pm 0,1)$ h (after the stress had been applied) to an accuracy of 0,01 mm.

Calculate the creep strain to the nearest 0,1 %, as follows:

$$\varepsilon_c = \frac{\Delta l}{l_0} \times 100 \quad (\%) \quad (3)$$

where

Δl is the change in length between 1 h and 4 h;

l_0 is the original length;

ε_c is the creep strain as a percentage.

Test three test-pieces. If all three results meet the requirement in [Table 2](#), it is not necessary to test the other two test-pieces.

If one of the three test-pieces fails to meet the requirement in [Table 2](#), test two more test-pieces.

Test no more than five test-pieces.

6.6 Determination of dimensional change during hardening

6.6.1 Apparatus

To measure the change in length during hardening, use an instrument that does not subject the test-piece to a restraint greater than 20 mN during the test and with which the change in test-piece length can be measured to an accuracy of 0,5 µm.

6.6.2 Preparation of the test-pieces

Prepare five test-pieces in accordance with 6.4.

Inspect the ends of each test-piece. In general, the ends of a test-piece will not have flash and will be perfectly flat and orthogonal to the cylinder axis, producing an acceptable test-piece. If necessary, remove any flash with a gentle rub on wet, coated abrasive that complies with microgrit size P1200, according to ISO 6344-1. Do not grind. After this, check that the ends are still flat and parallel.

NOTE Excessive abrasion can produce uneven removal, and as a consequence, the need to replace the test-piece.

6.6.3 Procedure

Maintain the test-piece at a temperature of (37 ± 1) °C during the 24 h test period.

Place each test-piece in the instrument immediately after its production. Measure the dimensional change that occurs between $(5,0 \pm 0,1)$ min and $(24,0 \pm 0,1)$ h from the end of mixing, to an accuracy of $0,5 \mu\text{m}$.

At $(24,0 \pm 0,1)$ h, after the test-piece has been removed from the instrument used to measure the change in length, measure the test-piece length to an accuracy of $0,01$ mm.

Calculate the dimensional change to the nearest $0,01$ %, as follows:

$$\varepsilon_d = \frac{\Delta l_d}{l_d} \times 100 \quad (\%) \quad (4)$$

where

Δl_d is the dimensional change between 5 min and 24 h;

l_d is the length at 24 h;

ε_d is the dimensional change as a percentage.

Test all five test-pieces

NOTE During the 24 h test period, the test-piece can remain in the measuring instrument and the length monitored continuously, or it can be removed from the measuring instrument after the first measurement, held at 37 °C without an applied force, and then returned to the measuring instrument for the second measurement.

6.7 Determination of compressive strength

6.7.1 Preparation of the test-pieces

Prepare the test-pieces in accordance with 6.4.

Make 20 test-pieces.

Inspect the ends of each test-piece. In general, the ends of a test-piece will not have flash and will be perfectly flat and orthogonal to the cylinder axis, producing an acceptable test-piece. If necessary, remove any flash with a gentle rub on wet, coated abrasive that complies with microgrit size P1200, according to ISO 6344-1. Do not grind. After this, check that the ends are still flat and parallel.

NOTE Excessive abrasion can produce uneven removal, and as a consequence, the need to replace the test-piece.

6.7.2 Procedure

Measure the diameter of each test-piece to an accuracy of 0,01 mm and record the value. Determine the compressive strength by means of a suitable mechanical testing machine. During the test, maintain the test-piece at a temperature of (23 ± 2) °C. Apply the force normally and uniformly over the cylinder ends at a crosshead speed of $(0,5 \pm 0,1)$ mm/min. For each test-piece, record the force that produces failure and calculate the compressive strength to the nearest 5 MPa.

6.7.3 Compressive strength at 1 h

Determine the compressive strength of five test-pieces at (60 ± 2) min after mixing.

If only three test-pieces meet the requirement for compressive strength at 1 h in [Table 2](#), determine the compressive strength of five more test-pieces.

Test no more than 10 test-pieces at 1 h.

6.7.4 Compressive strength at 24 h

Determine the compressive strength of five test-pieces at (24 ± 1) h after mixing.

If only three test-pieces meet the requirement for the compressive strength at 24 h in [Table 2](#), determine the compressive strength of five more test-pieces.

Test no more than 10 test-pieces at 24 h.

6.8 Appearance of the mixed dental amalgam before setting

6.8.1 Apparatus

6.8.1.1 Glass plate, with an area of at least 50 mm × 50 mm, a thickness of at least 5 mm and having glazed surfaces.

6.8.1.2 Mould and ejection components, comprising spacer no. 1, the die, and plunger no. 1 of the apparatus for making amalgam test-pieces that are specified in [Figures 3](#) and [4](#).

6.8.2 Procedure

Place spacer no. 1 on the glass plate. Upend plunger no. 1 in the centre hole of the spacer. Place the die over the protruding end of plunger no. 1, thereby creating a 5 mm deep cavity into which the dental amalgam will be packed.

Prepare the test-pieces at (23 ± 2) °C.

Mix according to [6.4.2](#). Use the amalgamator machine setting and the mixing time (for the mass of dental amalgam alloy present) that are recommended by the manufacturer of the product under test (see [7.3.1](#)). Use as many capsules, or dental amalgam alloy tablets, or as much free-flowing dental amalgam alloy powder as is needed to produce a cylinder that is 4 mm in length. Simultaneously, mix the contents of the capsules using the same number of amalgamators of the same brand and model, or sequentially mix the content of the capsules on a single amalgamator (The latter is allowable provided the mixing for the last capsule is completed before the end of the working time of the first.)

NOTE The mass of a 4 mm diameter dental amalgam cylinder 4 mm in length is approximately 0,6 g.

Use visual inspection without magnification to determine the appearance of the surface of the mixed dental amalgam and whether a coherent mass exists initially, immediately after mixing. Record this.

Carry out the inspection at an illuminance of at least 1000 lux and at a distance not exceeding 250 mm. A person making the inspection shall have nominally normal visual acuity. Corrective (non-magnifying) untinted lenses can be worn. Determine whether the surface is shiny.

At 30 s after the end of mixing, place a piece of mixed dental amalgam on the top of the die, over the cavity. The amount should be sufficient to fill the cavity to the extent that, after packing, approximately 1 mm of the cavity above the dental amalgam surface will remain unfilled. Pack immediately with 10 thrusts within a period of 10 s using a hand-instrument for amalgam packing that has a diameter of approximately 4 mm. Eject the specimen at 120 s after the end of mixing by removing the spacer and then pressing down on the die so that the plunger forces out the test-piece.

Use visual inspection under the same conditions as the initial inspection to determine whether a coherent mass has been maintained during packing. Record this.

7 Marking, labelling, and packaging

7.1 Packaging

A dental amalgam alloy product that is provided as a free-flowing powder in bulk quantities shall be packaged in a primary container that (under normal conditions of storage and use in a dental clinic) prevents spillage or contamination.

A dental amalgam alloy product that is provided as dental amalgam alloy tablets shall be packaged in a primary container that (under normal conditions of storage and use in a dental clinic) prevents contamination.

Dental mercury supplied in sachets shall be packaged in a container that (under normal conditions of storage and use in a dental clinic) prevents rupture of a sachet and in addition would contain any spillage.

The packaging of pre-capsulated products shall comply with the requirements in ISO 13897.

7.2 Marking

7.2.1 Information

The following information shall be included on the surface of the package and/or enclosed as part of accompanying printed literature:

- a) the type of material and its application;
- b) the product's brand or trade name;
- c) the name and address of the manufacturer or authorized representative in the country of sale;
- d) the lot number;
- e) for a pre-capsulated product, the mass of dental amalgam alloy in one capsule. For a dental amalgam alloy product supplied as a free-flowing powder in a bulk mass, the mass of dental amalgam alloy in the primary container. For a dental amalgam alloy product provided as dental amalgam alloy tablets, the mass of dental amalgam alloy in one tablet;
- f) for a pre-capsulated product, the mass of dental mercury in one capsule. For dental mercury product supplied in sachets, the mass of dental mercury in one sachet;
- g) for a pre-capsulated product, the number of capsules in each package. For a dental amalgam alloy product supplied as a free-flowing powder in a bulk mass, the number of primary containers in each package. For a dental amalgam alloy product supplied as dental amalgam alloy tablets, the number of tablets in each package. For dental mercury products supplied in sachets, the number of sachets in one package;

- h) a list of those elements present in the dental amalgam alloy in mass fractions greater than 0,1 %. If an element is present in a mass fraction greater than 0,5 %, its mass fraction shall also be listed to the nearest percentage point;
- i) a general description of the alloy particle shape(s);
- j) if the product contains dental mercury, a recommendation to store at a temperature no higher than 28 °C;
- k) in addition, for pre-capsulated products, the labelling shall be in accordance with the requirements of ISO 13897;
- l) if the product contains dental mercury, those pictograms, hazard statements, precautionary statements and signal words that are applicable to elemental mercury and that are mandatory on package inserts (or on accompanying literature) for the country in which the product is marketed. This shall be in accordance with the Globally Harmonized System of Classification and Labelling of Chemicals (GHS) (United Nations).

7.2.2 Labelling of a package for a product that contains dental mercury

Mark with the label given in [Figure 6](#). The general warning symbol and informative text shall comply with the requirements of ISO 3864-2 and the meaning of the symbol (number 5,4.4) in ISO 15223-1:2012, presented as follows:

- an exclamation mark within a triangle shall be printed in black on a white background;
- text information “CAUTION This product contains mercury” shall be printed in black;
- the outline of the box containing this cautionary symbol and text shall be printed in black.

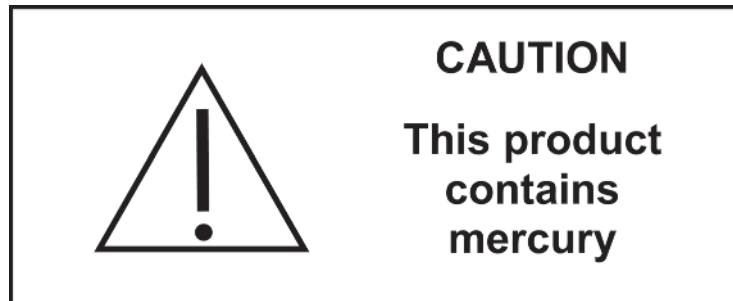

Figure 6 — Cautionary label

This labelling requirement is intended for the user, to advise the reader to consult the accompanying documents for important safety-related information. In this instance it is the information required by [7.2.1](#) and the precautionary notes contained in the manufacturer’s instructions ([7.3.2](#)).

7.2.3 Labelling of the outer surface of package or container used for shipping a product that contains dental mercury

For shipment, the container or outside packaging in which the package is placed shall be marked in accordance with the *UN Model Regulations on the Transport of Dangerous Goods*. Pictograms and additional safety information shall be applied that are appropriate for mercury (UN substance number 3506).

NOTE 1 Whereas [7.2.2](#) is information intended for the user, [7.2.3](#) is intended for shippers.

NOTE 2 In addition to this, labelling that is in accordance with the requirement for shipping mercury in the country or countries in which it is shipped or trans-shipped might be mandatory.

7.3 Manufacturer's instructions

7.3.1 General instructions for the use of products containing dental amalgam alloy

Printed instructions shall accompany each package and shall include at least the following information:

- a) for a dental amalgam alloy product supplied as a free-flowing powder in a bulk mass or as dental amalgam alloy tablets, the nominal recommended dental amalgam alloy: dental mercury ratio by mass. In addition, for a dental amalgam alloy product supplied as dental amalgam alloy tablets, the nominal recommended mass of dental mercury required for one dental amalgam alloy tablet;
- b) a specified brand and model number or name of an amalgamator complying with ISO 7488 that is recommended for mixing the amalgam alloy with dental mercury;
- c) for a dental amalgam alloy product supplied as a free-flowing powder in a bulk mass or as dental amalgam alloy tablets, a specified reusable mixing capsule that complies with ISO 13897 and is suitable for use with the amalgamator named on [7.3.1 b\)](#). If a pestle or any other specific mixing accessory is required, state this;
- d) for a product that is pre-capsulated the machine setting and the time required for the mixing of a capsule of dental amalgam using the amalgamator specified in [7.3.1 b\)](#);
- e) for a product that is a free-flowing powder dispensed into a reusable capsule, the amalgamator machine setting and the time required for mixing a recommended mass of dental amalgam alloy in a mix with dental mercury at the recommended ratio using the amalgamator named in [7.3.1 a\)](#) in the re-usable capsule named in [7.3.1 c\)](#);
- f) for a product that is supplied as dental amalgam alloy tablets, the amalgamator machine setting and the time required for mixing a recommended number of dental amalgam alloy tablets with the recommended mass of dental mercury (i.e. at the recommended ratio) using the amalgamator named in [7.3.1 a\)](#) in the re-usable capsule named in [7.3.1 c\)](#);
- g) a description of the initial characteristics of a correctly-mixed amalgam, such as the initial appearance (reflectivity), texture and coherence.

7.3.2 Precautionary notes

The manufacturer's printed instructions shall contain the following precautionary notes:

- a) Effect of mercury on metals

"Mercury reacts with and embrittles particular metals and their alloys. Avoid unnecessary contact between mercury and those metals (and their alloys)";

- b) Spillages

"Mercury presents a health hazard if handled incorrectly. Mercury is toxic by vapour inhalation and the effect is cumulative. Spillages of mercury should be removed immediately, including from places which are difficult to access. Use a plastic syringe to draw it up. Smaller quantities can be covered by sulfur powder and removed. Individual small droplets can be picked up by tin (i.e. Sn) foil and removed. Avoid inhalation of the vapour. During and after a clean-up thoroughly ventilate the area where the spill has occurred. Vacuum cleaners should not be used";

- c) Moisture contamination

"If moisture is introduced into the dental amalgam before it has set, properties such as strength and corrosion resistance can be affected adversely. If the alloy contains zinc, such contamination can result in an excessive expansion (delayed expansion). Use a dry field, whenever it is possible";

- d) Waste disposal

“Waste material and all primary containers that have held mercury shall be disposed of following appropriate management practice”.

Bibliography

- [1] ISO 7405, *Dentistry — Evaluation of biocompatibility of medical devices used in dentistry*
- [2] ISO 10993-1, *Biological evaluation of medical devices — Part 1: Evaluation and testing within a risk management process*
- [3] ISO/TS 17988, *Dentistry — Corrosion test methods for dental amalgam*

British Standards Institution (BSI)

BSI is the national body responsible for preparing British Standards and other standards-related publications, information and services.

BSI is incorporated by Royal Charter. British Standards and other standardization products are published by BSI Standards Limited.

About us

We bring together business, industry, government, consumers, innovators and others to shape their combined experience and expertise into standards-based solutions.

The knowledge embodied in our standards has been carefully assembled in a dependable format and refined through our open consultation process. Organizations of all sizes and across all sectors choose standards to help them achieve their goals.

Information on standards

We can provide you with the knowledge that your organization needs to succeed. Find out more about British Standards by visiting our website at bsigroup.com/standards or contacting our Customer Services team or Knowledge Centre.

Buying standards

You can buy and download PDF versions of BSI publications, including British and adopted European and international standards, through our website at bsigroup.com/shop, where hard copies can also be purchased.

If you need international and foreign standards from other Standards Development Organizations, hard copies can be ordered from our Customer Services team.

Subscriptions

Our range of subscription services are designed to make using standards easier for you. For further information on our subscription products go to bsigroup.com/subscriptions.

With **British Standards Online (BSOL)** you'll have instant access to over 55,000 British and adopted European and international standards from your desktop. It's available 24/7 and is refreshed daily so you'll always be up to date.

You can keep in touch with standards developments and receive substantial discounts on the purchase price of standards, both in single copy and subscription format, by becoming a **BSI Subscribing Member**.

PLUS is an updating service exclusive to BSI Subscribing Members. You will automatically receive the latest hard copy of your standards when they're revised or replaced.

To find out more about becoming a BSI Subscribing Member and the benefits of membership, please visit bsigroup.com/shop.

With a **Multi-User Network Licence (MUNL)** you are able to host standards publications on your intranet. Licences can cover as few or as many users as you wish. With updates supplied as soon as they're available, you can be sure your documentation is current. For further information, email bsmusales@bsigroup.com.

BSI Group Headquarters

389 Chiswick High Road London W4 4AL UK

Revisions

Our British Standards and other publications are updated by amendment or revision.

We continually improve the quality of our products and services to benefit your business. If you find an inaccuracy or ambiguity within a British Standard or other BSI publication please inform the Knowledge Centre.

Copyright

All the data, software and documentation set out in all British Standards and other BSI publications are the property of and copyrighted by BSI, or some person or entity that owns copyright in the information used (such as the international standardization bodies) and has formally licensed such information to BSI for commercial publication and use. Except as permitted under the Copyright, Designs and Patents Act 1988 no extract may be reproduced, stored in a retrieval system or transmitted in any form or by any means – electronic, photocopying, recording or otherwise – without prior written permission from BSI. Details and advice can be obtained from the Copyright & Licensing Department.

Useful Contacts:

Customer Services

Tel: +44 845 086 9001

Email (orders): orders@bsigroup.com

Email (enquiries): cservices@bsigroup.com

Subscriptions

Tel: +44 845 086 9001

Email: subscriptions@bsigroup.com

Knowledge Centre

Tel: +44 20 8996 7004

Email: knowledgecentre@bsigroup.com

Copyright & Licensing

Tel: +44 20 8996 7070

Email: copyright@bsigroup.com



...making excellence a habit.™