

Soil quality — Sampling of soil invertebrates —

Part 4: Sampling, extraction and identification of soil-inhabiting nematodes

ICS 13.080.05; 13.080.30

National foreword

This British Standard is the UK implementation of EN ISO 23611-4:2011. It is identical to EN ISO 23611-4:2011. It supersedes BS ISO 23611-4:2007, which is withdrawn.

The UK participation in its preparation was entrusted to Technical Committee EH/4, Soil quality.

A list of organizations represented on this committee can be obtained on request to its secretary.

This publication does not purport to include all the necessary provisions of a contract. Users are responsible for its correct application.

Compliance with a British Standard cannot confer immunity from legal obligations.

This British Standard was published under the authority of the Standards Policy and Strategy Committee on 29 February 2008

© BSI 2011

Amendments/corrigenda issued since publication

Date	Comments
31 August 2011	This corrigendum renumbers BS ISO 23611-4:2007 as BS EN ISO 23611-4:2011

ISBN 978 0 580 73165 5

EUROPEAN STANDARD

EN ISO 23611-4

NORME EUROPÉENNE

EUROPÄISCHE NORM

July 2011

ICS 13.080.30; 13.080.05

English Version

Soil quality - Sampling of soil invertebrates - Part 4: Sampling, extraction and identification of soil-inhabiting nematodes (ISO 23611-4:2007)

Qualité du sol - Prélèvement des invertébrés du sol - Partie 4: Prélèvement, extraction et identification des nématodes du sol (ISO 23611-4:2007)

Bodenbeschaffenheit - Probenahme von Wirbellosen im Boden - Teil 4: Probenahme, Extraktion und Bestimmung von Boden bewohnenden Nematoden (ISO 23611-4:2007)

This European Standard was approved by CEN on 17 June 2011.

CEN members are bound to comply with the CEN/CENELEC Internal Regulations which stipulate the conditions for giving this European Standard the status of a national standard without any alteration. Up-to-date lists and bibliographical references concerning such national standards may be obtained on application to the CEN-CENELEC Management Centre or to any CEN member.

This European Standard exists in three official versions (English, French, German). A version in any other language made by translation under the responsibility of a CEN member into its own language and notified to the CEN-CENELEC Management Centre has the same status as the official versions.

CEN members are the national standards bodies of Austria, Belgium, Bulgaria, Croatia, Cyprus, Czech Republic, Denmark, Estonia, Finland, France, Germany, Greece, Hungary, Iceland, Ireland, Italy, Latvia, Lithuania, Luxembourg, Malta, Netherlands, Norway, Poland, Portugal, Romania, Slovakia, Slovenia, Spain, Sweden, Switzerland and United Kingdom.



EUROPEAN COMMITTEE FOR STANDARDIZATION
COMITÉ EUROPÉEN DE NORMALISATION
EUROPÄISCHES KOMITEE FÜR NORMUNG

Management Centre: Avenue Marnix 17, B-1000 Brussels

Foreword

The text of ISO 23611-4:2007 has been prepared by Technical Committee ISO/TC 190 “Soil quality” of the International Organization for Standardization (ISO) and has been taken over as EN ISO 23611-4:2011 by Technical Committee CEN/TC 345 “Characterization of soils” the secretariat of which is held by NEN.

This European Standard shall be given the status of a national standard, either by publication of an identical text or by endorsement, at the latest by January 2012, and conflicting national standards shall be withdrawn at the latest by January 2012.

Attention is drawn to the possibility that some of the elements of this document may be the subject of patent rights. CEN [and/or CENELEC] shall not be held responsible for identifying any or all such patent rights.

According to the CEN/CENELEC Internal Regulations, the national standards organizations of the following countries are bound to implement this European Standard: Austria, Belgium, Bulgaria, Croatia, Cyprus, Czech Republic, Denmark, Estonia, Finland, France, Germany, Greece, Hungary, Iceland, Ireland, Italy, Latvia, Lithuania, Luxembourg, Malta, Netherlands, Norway, Poland, Portugal, Romania, Slovakia, Slovenia, Spain, Sweden, Switzerland and the United Kingdom.

Endorsement notice

The text of ISO 23611-4:2007 has been approved by CEN as a EN ISO 23611-4:2011 without any modification.

Contents

Page

1	Scope	1
2	Terms and definitions.....	1
3	Principle	2
4	Reagents	3
5	Apparatus	3
5.1	Sampling.....	4
5.2	Extraction	4
5.3	Counting	4
5.4	Fixation and preparation of mass slides	5
5.5	Identification.....	5
6	Procedure	5
6.1	General.....	5
6.2	Sampling.....	5
6.3	Extraction	6
6.4	Counting	7
6.5	Fixation and preparation of mass slides	7
6.6	Identification.....	8
7	Data assessment.....	8
8	Study report.....	9
	Annex A (informative) Figures of equipment and methods for nematological research.....	10
	Annex B (informative) Information about the availability of the Oostenbrink elutriator.....	13
	Annex C (informative) Information about the Baermann funnel/tray extraction method	15
	Bibliography	17

Foreword

ISO (the International Organization for Standardization) is a worldwide federation of national standards bodies (ISO member bodies). The work of preparing International Standards is normally carried out through ISO technical committees. Each member body interested in a subject for which a technical committee has been established has the right to be represented on that committee. International organizations, governmental and non-governmental, in liaison with ISO, also take part in the work. ISO collaborates closely with the International Electrotechnical Commission (IEC) on all matters of electrotechnical standardization.

International Standards are drafted in accordance with the rules given in the ISO/IEC Directives, Part 2.

The main task of technical committees is to prepare International Standards. Draft International Standards adopted by the technical committees are circulated to the member bodies for voting. Publication as an International Standard requires approval by at least 75 % of the member bodies casting a vote.

Attention is drawn to the possibility that some of the elements of this document may be the subject of patent rights. ISO shall not be held responsible for identifying any or all such patent rights.

ISO 23611-4 was prepared by Technical Committee ISO/TC 190, *Soil quality*, Subcommittee SC 4, *Biological methods*.

ISO 23611 consists of the following parts, under the general title *Soil quality — Sampling of soil invertebrates*:

- *Part 1: Hand-sorting and formalin extraction of earthworms*
- *Part 2: Sampling and extraction of micro-arthropods (Collembola and Acarina)*
- *Part 3: Sampling and soil extraction of enchytraeids*
- *Part 4: Sampling, extraction and identification of soil-inhabiting nematodes*

Introduction

This part of ISO 23611 has been drawn up since there is a growing need for the standardization of terrestrial zoological field methods. Such methods, mainly covering the sampling, extraction and handling of soil invertebrates, are necessary for the following purposes:

- biological classification of soils including soil quality assessment [15],[17],[28];
- terrestrial bio-indication and long-term monitoring [9],[10],[13],[24];
- evaluation of the effects of chemicals on soil animals (ISO 11268-3).

Data for these purposes are gained by standardized methods since they can form the basis for far-reaching decisions (e.g. whether a given site should be remediated or not). In fact, the lack of such standardized methods is one of the most important reasons why bio-classification and bio-assessment in terrestrial (i.e. soil) habitats has so far been relatively rarely used in comparison to aquatic sites.

Nematodes are an important and major part of the soil fauna. Some authors estimate that this group is probably the most dominant one of the multicellular organisms (Metazoa) on earth. Nematodes occur from the Antarctic to the tropics and from deep sea sediments to mountain regions. They are active in every place with sufficient water and organic material. The species diversity and functional variety are impressive. Nematodes are commonly known as parasites of animals and plants, but the major part of the nematode fauna participates in decomposition processes by feeding on bacteria and fungi.

Nematodes occur in high numbers [(5 000 to 100 000)/kg fresh soil] and with a high (20 to 100) species diversity in almost every soil sample. Moreover, there is a broad ecological spectrum of feeding types and food web relations among the nematodes such as bacterivores, fungivores, herbivores, predators and omnivores [27],[28]. These factors make the group highly suitable as indicators for ecological soil quality, but standardization of methods is urgently needed for comparison and combination of results.

In the past 100 years, nematology has developed strongly from the viewpoint of agriculture, advisory sampling and phytosanitary regulations because some terrestrial nematodes cause a lot of damage in crops. With respect to methods, there are several "schools" in different parts of the world with their own history, practical advantages and disadvantages. A comprehensive overview is given by Oostenbrink [14] and Southey [22],[23]. The more recently described methods (or variants) are often developed with special interest to certain plant-parasitic species.

Since Bongers [4] introduced the Maturity Index, the use of nematodes in bio-indication for soil quality has increased rapidly. Nematodes are now used for ecological soil research and monitoring in several countries all over the world. Monitoring activities make special demands on methodology, for instance, that a large number of soil samples is processed on a routine basis against reasonable costs. Some of the methods originally developed for advisory sampling in agriculture are very suitable for ecological research. They form the basis for specific variants described in this document.

Soil quality — Sampling of soil invertebrates —

Part 4: Sampling, extraction and identification of soil-inhabiting nematodes

1 Scope

This part of ISO 23611 specifies a method for sampling and handling free-living nematodes from terrestrial field soils as a prerequisite for using them as bio-indicators (e.g. to assess the quality of a soil as a habitat for organisms).

This part of ISO 23611 applies to all terrestrial biotopes in which nematodes occur. The sampling design of field studies in general is specified in ISO 10381-1.

This part of ISO 23611 is not applicable to aquatic nematodes because these nematodes do not pass through the filter. Methods for some other soil organism groups such as earthworms, enchytraeids or collembolans are covered in other parts of ISO 23611.

The nematodes that are characterized by the proposed procedure are all the free-living forms of nematodes found in soil. They include non-plant-feeding nematodes as well as ectoparasitic plant-feeding nematodes and free-living stage of endoparasitic nematodes. The quantification of obligate plant-feeding nematodes in roots requires specific methods.

NOTE Basic information on the ecology of nematodes and their use as bio-indicators can be found in the bibliography.

This part of ISO 23611 does not cover the pedological characterization of the site which is highly recommendable when sampling soil invertebrates. ISO 10390, ISO 10694, ISO 11272, ISO 11274, ISO 11277, ISO 11461 and ISO 11465 are more suitable for measuring pH, particle size distribution, C/N ratio, organic carbon content and water-holding capacity.

2 Terms and definitions

For the purposes of this document, the following terms and definitions apply.

2.1

nematode

small, non-segmented free-living worm (up to a few millimetres in length) belonging to the class Nematoda

NOTE Nematodes without a soil-inhabiting stage are not included in this context.

2.2

location

study area or plot that is characterized based on the composition of (among others) the nematode fauna

BS EN ISO 23611-4:2011 EN ISO 23611-4:2011 (E)

2.3
bulk-sample
composite soil sample made out of many small soil cores to get an impression of the average nematode composition

2.4
soil sampler
tool to collect soil material in a quick and standardized way

2.5
Oostenbrink elutriator ¹⁾
metal funnel with an upward water flow to separate nematodes from larger soil particles

See Figure A.3.

2.6
mass slide
microscopic slide on which 300 to 400 nematodes are mounted for species identification

2.7
identification
determination of the species, genus or family of an individual based on morphological characteristics (mouth parts, sexual organs, body ratios) with an identification key

2.8
colonizer – persister (cp) scale
ecological classification of nematodes, proposed by Bongers [4],[5]

NOTE The principle is analogous to the r-K life strategies during succession, distinguished in fundamental ecology. Non-plant-feeding nematode families are classified to one of the five cp-groups. This is also the basis for the calculation of the Maturity Index.

3 Principle

Nematodes are collected in soil samples with a small cylindrical core (diameter: circa 2 cm; length: 10 cm) or an auger (see Figure A.2). For monitoring purposes, the soil samples are combined in a bulk-sample from a homogeneous area. The total number of samples to be taken depends on the investigated surface area and its homogeneity (e.g. pedology, culture). The individual samples can be gathered in the field in a standard plastic bag or plastic bucket. The combined bulk-sample is too large for direct examination and therefore it is mixed and subsampled. In the field and during transport to the laboratory, the soil samples shall be protected against strong fluctuations in temperature, water-loss and heavy mechanical disturbance. They can be stored for at most four weeks at 4 °C.

NOTE 1 The sampling method described above is derived from “the Dutch Method” [23] for determining the infestation of a field with potato-cyst nematodes, and has been used for many years in several European countries.

1) Oostenbrink elutriator is the trade name of a product supplied by firm Eijkelkamp, Giesbeek, NL (<http://www.eijkelkamp.nl>). This information is given for the convenience of users of this International Standard and does not constitute an endorsement by ISO of the product named. Equivalent products may be used if they can be shown to lead to the same results.

The Oostenbrink funnel method is recommended for routine extractions of soil samples, for instance in a monitoring network. The Oostenbrink method is not the most simple one that can be used under any circumstance. However, it has several advantages: it is highly standardized and constant in extraction efficiency. The Oostenbrink wet funnel method combines three basic means that can be used for the separation of nematodes from soils: washing, sieving, active movement. Therefore, it obtains better results than any one of the basic methods individually. Further advantages are given below:

- relatively large soil samples of any soil type can be treated at once (100 g to 500 g);
- clean nematode suspensions;
- isolation of most living and active nematodes;
- there are many years of experience with enormous amounts of routine soil extractions;
- it is used in many places around the world.

After sampling, the nematodes are extracted from the soil using the Oostenbrink elutriator ¹⁾ (model III) (see Figure A.3 and Annex B). In this technique, an upward current of water separates the nematodes from soil particles and holds them in suspension while the heavier particles sink [1],[14],[19],[23]. This suspension of nematodes and small particles passes through three sieves (mesh width: 45 µm). The catch is washed from the sieves onto a cotton-wool filter (milk filter). The cotton-wool filter is mounted on a supporting sieve and is placed in a dish with 100 ml of tap water. For three days, through their active downwards movement, the nematodes separate themselves from the debris on the filter. Thus, the living nematodes actively crawl through the filter in a dish with tap water.

After extraction, the nematodes are counted in 2 × 10 % of the 100 ml suspension, then concentrated, preserved and mounted on mass slides. Finally, at least 150 individuals or a fixed percentage of the total number in the sample is identified under the microscope.

Mature nematodes can be identified to species level. However, populations in the soil are often dominated by juveniles and the general level of taxonomy is a practical (but less sensitive) way of distinction.

Alternative extraction methods such as the Seinhorst elutriator [19] or Baermann funnel (Annex C) can be useful under special circumstances, but are not recommended as general procedures because the Oostenbrink elutriator is robust, easy to operate and usually quantitatively superior to most other techniques. As an alternative, centrifugation techniques are most suitable.

NOTE 2 This part of ISO 23611 is not applicable for aquatic nematodes because these nematodes do not pass through the filter. Special centrifugation techniques are available for sediment samples.

NOTE 3 Determination with a light microscope is based on morphological characteristics. In some cases, it is not possible to recognize the specimen on species level, e.g. juveniles. With a new technique based on DNA analysis, juveniles can be identified to species level. This new technique is expected to become operational within several years.

4 Reagents

4.1 **Formalin** [formaldehyde solution, 6 % (volume fraction)].

4.2 **Paraffin**, with melting point near 60 °C.

5 Apparatus

Use standard laboratory equipment and the following.

5.1 Sampling

5.1.1 Soil sampler, of an open, closed or split-tube type.

EXAMPLE Grass plot sampler (diameter: 23 mm) or soil auger (Figures A.2 and A.3); commercially available.

5.1.2 Plastic bucket (collection of soil samples in the field).

5.1.3 Plastic container, for mixing of the bulk-sample.

5.1.4 Sieve, with 8 mm apertures.

5.1.5 Coated bags or plastic bags or glass vessels (transport and storage).

5.1.6 Permanent marker or pre-printed labels.

5.2 Extraction

5.2.1 Beaker, of capacity 100 ml to 250 ml.

5.2.2 Balance, able to weigh 1 kg to 25 kg, for weighing the total sample mass.

5.2.3 Oostenbrink elutriator ¹⁾ (see also Annex B).

5.2.4 Three sieves, with 45 µm apertures and 30 cm diameters.

5.2.5 One sieve, with 250 µm apertures and a 10 cm diameter.

5.2.6 Plastic bowl, of capacity circa 2 l.

5.2.7 Clamping ring.

5.2.8 Extraction sieve, with 1 000 µm apertures and 16 cm diameter.

5.2.9 Milk- or cotton-wool filters.

5.2.10 Shallow trays (Petri dishes) or **special extraction dishes**.

5.2.11 Glass vessel, of capacity 100 ml, with a screw-cap.

5.3 Counting

5.3.1 Dissecting microscope, 10× to 50× magnification.

5.3.2 Small counting dish with grid or glass slide with grid.

NOTE Counting dishes in several sizes and different grids are available from the manufacturers of laboratory equipment. They can also be made out of small plastic Petri dishes by scratching a grid on the bottom with a needle.

5.3.3 Simple hand counting device.

5.3.4 Aquarium pump, for mixing nematode suspensions.

5.3.5 Pipette (drop glass), with adjustable volume.

5.3.6 Handling needle.

5.3.7 Bottle, of volume 100 ml.

5.4 Fixation and preparation of mass slides

- 5.4.1 **Water jet pump**, for concentration of suspension.
- 5.4.2 **Glass slides**, 50 mm × 76 mm.
- 5.4.3 **Cover glasses**, 45 mm × 45 mm.
- 5.4.4 **Electric heating plate**.
- 5.4.5 **Metal stamp**, 40 mm × 40 mm, for paraffin seal on glass slides.

5.5 Identification

- 5.5.1 **Microscope**, magnification 400× to 1 000×.
- 5.5.2 **Ocular micrometer indicator**.
- 5.5.3 **Identification keys** [3].
- 5.5.4 **Standard form**, to list the identification results.

6 Procedure

6.1 General

For quality assurance, each sample shall be given a unique code from the moment it is taken in the field. This code (label) shall stay with the sample during all the processing and analysis steps. Standard (electronic) form(s) should be used to follow the routing of the samples and collection of analysis results. These basic data may be combined in a spreadsheet or database file for further calculations and statistical testing.

6.2 Sampling

While the density and diversity of soil nematodes are the highest in the top 10 cm of the mineral soil, a grass plot sampler (5.1.1) with a 10 cm or 15 cm long sampling-tube is appropriate for most biomonitoring purposes. It is recommended to use a closed tube with a fixed length and diameter.

EXAMPLE 1 A grass plot sampler consists of a stainless steel gouge auger (available in different dimensions) consisting of a steel auger pipe, a collecting bucket (5.1.2) and a stick with a steel handle. Because of the conical shape of the pipe, the sample is easily pushed toward the collecting bucket when the next sample is taken. The sample depth is constant and soil cores can be collected easily over a large area (see Figure A.1). This device can be used in many situations.

EXAMPLE 2 Alternatively, a soil auger can be used as a simple, cheap and quick working device. Augers are available in different diameters. Soil samples collected with an auger are less compressed. The disadvantage is that soil material can be lost more easily (see Figure A.2).

EXAMPLE 3 When accurate separation of soil layers is required, a split-tube sampler can be used. This sampling device needs more handling time and is less suited for large numbers of samples and large areas (see Figure A.2).

Samples from deeper layers can be taken with an auger to avoid excessive soil compression, or special split-tube samplers (see Figure A.2). Organic or litter material can be included in the samples, but it increases the numbers of nematodes found, sometimes considerably. Organic layers may be sampled independently. In this case, a wider split-tube corer (5 cm to 10 cm) is preferred in order to separate the organic horizons from the mineral material. Small amounts of litter can also be treated in an Oostenbrink elutriator¹⁾ (5.2.3) to extract the nematodes. Extraction efficiency can be enhanced by soaking and blending the organic parts [16],[18].

BS EN ISO 23611-4:2011 EN ISO 23611-4:2011 (E)

When a representative sample is required from a specific type of ecosystem, a typical area of at least 0,5 ha, and preferably 1 ha, shall be selected. It is recommended to select an area which is (more or less) homogeneous in terms of soil properties, vegetation and soil-use. The studied surface is reported as part of the location information. As a rule of thumb, 100 soil cores shall be combined from 1 ha. For smaller areas (e.g. 100 m²), circa 25 cores are sufficient to get an impression of the average nematode composition and to collect enough soil material. A denser sampling pattern results in a higher accuracy in the estimation of nematode abundance and species composition. However, there is a trade-off with the amount of subsample that is finally analysed from the homogenized bulk soil sample. So, a very large bulk-sample does not give more information because only a small part is analysed and homogenization cannot be completely perfect. Three hundred samples with a grass plot sampler (diameter 23 mm) are recommended as a maximum for a composite bulk-sample. In a biomonitoring programme, the sample density per surface area should preferably be equal in all locations. The mass of the bulk-sample and the number of soil cores in it need to be known.

The sampling plan may be regular (grid), according to a pattern or random. For larger locations, it is most practical to walk a zigzag pattern and take arbitrary samples along this route. In the case that a location consists of different parcels, the number of soil samples shall be distributed over the parcels based on their area. Samples from very atypical parts of the location such as ditches, tracks or pathways shall be avoided.

The collected bulk-sample is homogenized in a plastic container (5.1.3). This can be done in the field or laboratory, depending on the most practical way of working and transport. Mixing starts with crumbling of the cores through a 8 mm aperture sieve (5.1.4). Subsequently, the soil is gently mixed until the mass is uniform in colour and consistency. Mixing and preparation of the sample can take more than an hour for bulk-samples from clay soils or densely rooted top soils. However, this step is essential to all the analyses that are based on it and should be given enough attention. Coarse organic material, roots and stones shall be removed. The final choice for details of working shall be specified in the field sampling protocol, and again shall be uniform for the entire biomonitoring programme.

When the bulk-sample is homogenized, circa one litre is taken out for further examination. This can be done by several spoonfuls from different parts of the bulk to obtain a representative subsample. Put the sample in a labelled plastic bag or glass vessel (5.1.5). At this point, more subsamples can be taken from the bulk for other biotic and abiotic analyses. Soil samples for nematode analysis shall be stored at 4 °C prior to extraction. The storage period should be kept as short as possible, four weeks at the maximum. This temperature may not be optimal for all nematodes (e.g. Aphelenchoididae, Anguinidae; see Reference [39]). In any case, the appropriate temperature shall be checked beforehand when sampling outside of the holarctic region (e.g. in the tropics).

6.3 Extraction

Mix the soil (sub)sample from the field again before extraction and fill a beaker (5.2.1) with 100 ml to 250 ml of soil. Weigh the sample in order to convert the results to a fresh-weight basis. In another sub-part of the same soil sample, measure the soil humidity to express final density as a unit of soil dry-weight. Store the remaining sample for abiotic analysis, unless material was collected separately in the field from the same bulk-sample.

Prepare the Oostenbrink elutriator (5.2.3). Put the sample in the top sieve and wash the soil in the elutriator. Specific water flow speeds depend on the type of funnel used. A detailed description of the apparatus and the way to use it is given in Reference [23] and Reference [1]. The latest version of the Oostenbrink funnel has larger dimensions and is fully automated (see Figure A.5). It is suited for routine extraction of large numbers of samples. The soil sample is washed into the funnel through the top sieve. When the funnel is filled by the upward stream of water, the nematodes are separated from the heavier soil particles.

NOTE 1 If for whatever reason an Oostenbrink elutriator is not available, the Baermann funnel/tray method can be an alternative. Details concerning its use are given in Annex C.

Unplug the funnel when the water has reached the edge and catch the water flow on a pile of three sieves with 45 µm pore size (5.2.4). An additional top sieve (5.2.5) can be mounted on the three sieves (5.2.4) to catch large nematodes that do not pass the final cotton-wool filter step. This sieve (5.2.5) shall be placed directly in an extraction disk (shallow tray filled with water) (5.2.10) and stored in a cabinet for three days. At higher ambient temperatures, the cabinet should be humidified and kept away from heat sources. The sieves (5.2.4) are rinsed with a gentle stream of water which is caught in a plastic bowl (5.2.6). The suspension with

the nematodes can be set aside for 15 min to 30 min, during which time the nematodes settle to the bottom. It has the advantage that the supernatant water in the plastic bowl can be poured out more quickly. Pour the content of the bowl over a double filter [e.g. cotton-wool (milk)] (5.2.9), which is clipped onto an extraction sieve (5.2.8) with a clamping ring (5.2.7). Place the extraction sieve (5.2.8) with debris in an extraction dish (5.2.10). The active nematodes in the debris crawl through the filter (5.2.9) in the extraction dish (5.2.10) with 100 ml of tap water during a period of three days. It is important that the filter (5.2.9) stays in contact with the water in the extraction dish (5.2.10). If necessary, add tap water during the three-day period. After three days, both the 250 µm pore size sieve (5.2.5) and the sieve with cotton-wool filters (5.2.9) are removed and the content of the extraction dishes (5.2.10) can be poured into a glass vessel of 100 ml (5.2.11). Label the vessels with the correct sample codes. Subsequently, the nematodes can be counted.

NOTE 2 Other filter material than a cotton-wool filter is acceptable as long as it has been shown that its properties equal those of cotton wool with respect to nematode extraction (i.e. no change in pore size after absorption of water).

NOTE 3 This method allows the user to extract only mobile forms. Therefore, the count does not take into account the motionless forms (eggs, dead organisms in the soil). This type of extraction does not give the exact value of the number of nematodes (at any stage of development) at the time of the extraction. Centrifugation allows the extraction of all the forms of nematodes, but this method can also destroy nematodes.

NOTE 4 A period of three days is recommended for the last extraction phase. In this step, the cotton-wool filters (in a supporting sieve) are placed in a shallow dish with 100 ml tap water. Experimental results show that 59 % of the nematodes crawl out during the first 24 h, 73 % after two days, and 82 % are caught after three days [25]. These numbers are based on a comparison with the nematodes found after seven days. For practical reasons, a standard extraction period of three days is chosen. A longer extraction time has the disadvantages that the water in the dishes evaporates, nematodes can die, and eggs present in the debris possibly hatch.

6.4 Counting

Before counting, combine the contents of the two vessels (5.2.11) containing the nematodes from one soil sample. Wait at least 2 h to be sure that the nematodes have sunk to the bottom. Concentrate the suspensions (decanting or suction) so that suspensions fit in one 100-ml bottle (5.3.7 or 5.2.11). If necessary, add tap water to the vessel until it contains exactly 100 ml. Mix the suspension with air (5.3.4) thoroughly (3 min to 5 min). Immediately afterwards take out 10 ml mixed suspension with a pipette (5.3.5) and put it in a counting dish (5.3.2). Do this in duplicate. Count the number (5.3.3) of nematodes under a stereomicroscope (5.3.1) while moving the counting dish slowly around. The result of the two counts shall be within 10 % difference. Otherwise, the suspension was probably not homogenous enough and the counting procedure shall be repeated. Note the number of nematodes in each counting dish on a standard form. The average number of the duplicate count, scaled up to 100 ml suspension, is the estimation of the nematode abundance in the extracted amount (volume or weight) of soil. Put the counted subsample back in the 100-ml bottle (5.3.7). Next, the nematodes shall be heat killed and fixed with formalin (4.1).

The volume of the suspension in the vessels and the volume of the mixed suspension taken out with the pipette for counting depend on the density of the nematodes in the vessels. Although a suspension volume of 100 ml and the amount taken out for counting (10 ml) work well in most cases, this can be changed. Almost all nematodes from the soil sample should be counted if the nematode density is very low, while only 1 % of suspension may include already too many nematode individuals if the original density in the soil is very high.

WARNING — Appropriate precautions should be taken when dealing with formalin to avoid danger from inhalation or skin exposure (such as wearing gloves and handling the samples in a fume cupboard). According to the “Material Safety Data Sheet” for formaldehyde 37 % solution as published by producing companies, the compound is a skin sensitizer and is considered to be a carcinogen (humans: limited evidence; animals: sufficient evidence). It is notified in industrialized countries and is allowed for scientific use.

6.5 Fixation and preparation of mass slides

If recently counted, let the nematodes sink to the bottom of the vessel for several hours. Meanwhile, the suspension may be kept in a refrigerator at 4 °C. Concentrate the suspension until about 5 mm of water is left in the vessel. This can be done with a small pipette (5.3.5) connected to a (water flow) vacuum pump (5.4.1). A piece of plankton gauze (10 µm pore size) stretched over the opening of the pipette prevents the loss of

nematodes. Add circa 10 ml of boiling water to the concentrated sample to kill and stretch the nematodes. Add circa 30 ml formalin (4.1) to preserve the sample. The sample can then be kept for a reasonably long period (i.e. several months) and mass slides can be prepared for species identification.

Concentrate the sample again before the preparation of mass slides. Prepare the slides (5.4.2) by adding a small paraffin square (ridge) (4.2) with a heated stamp (5.4.5). Press the stamp briefly on the paraffin so that it can melt and stick to the stamp. Then put the stamp on the glass slide. Make two slides for every sample. Add two drops of (shaken) suspension to each slide. Put a cover glass (5.4.3) over the paraffin square of circa 40 mm by 40 mm and the nematodes in the drops of fixative. Heat the slide on a hot plate (5.4.4) to 65 °C so that the paraffin melts again. Remove the slides directly otherwise the nematodes can be damaged. The paraffin becomes solid and the nematodes are mounted in the slides. Mark the slides with the number of the sample and A or B. The slides can be stored for several months.

NOTE The selection of the fixation method depends on the objective of the study. For a taxonomic description, holotypes are prepared by dehydration of the animals followed by a transfer to anhydrous glycerol [48]. For monitoring purposes, heat fixation and temporal mounts (weeks to several months) as described above are enough and are practically feasible.

6.6 Identification

The A and B slides (see 6.5) of the same sample are analysed, if possible, by different persons. Use a light microscope (5.5.1) for identification. Special optic techniques like interference contrast (5.5.2) can be useful to make structures visible. In each slide, 75 specimens are identified, using a nematode identification key (5.5.3). Alternatively, a constant fraction (%) of the total number in the sample can be identified in order to maintain a constant level of identification-resolution.

Write down the taxon name (family, genus or species name) of each specimen and characterize it as a male, female or juvenile. The identification keys in Reference [3] cover most of the European free-living species. Other standard works are the books of Reference [2] and Reference [21]. For a few groups, specific publications shall be used in order to identify the species. Juveniles without fully grown sex-organs and other morphologic structures can only be identified to genus level in most of the cases. Resting stages (dauerlarvae) are counted as a separate group.

Results of the identifications and proportions between taxa are used to estimate the numbers per species in the original soil sample. Calculations can be performed in a spreadsheet computer program.

7 Data assessment

The results of nematode counts and identifications are stored in an electronic database (spreadsheet or database program). The basic data of the analyses are converted to unit of soil fresh-weight, dry-weight and surface area (dm² or m²). The “per unit area” values can be calculated from the diameter of the soil core, the number of cores in the bulk-sample, the total weight of the bulk-sample and the weight of the extracted amount of soil. Taxon composition is assigned to feeding groups according to Reference [27]. Use the colonizer – persister (cp) scale for ecological characterization (see Reference [5]). After this, the Maturity Index [4],[5] and proportions of feeding groups can be calculated beside standard diversity indices.

The following measurement endpoints can be used for the bio-classification of a soil, as well as the evaluation of effects of chemical or anthropogenic stress:

- total abundance;
- number of species;
- number of species in feeding groups and cp-classes;

- ratio of bacterial and fungal feeding groups (NCR-ratio):

$$\text{NCR} = \frac{B}{(B + F)}$$

where

- NCR is the nematode channel ratio;
- B* is the fraction bacterial feeding;
- F* is the fraction fungal feeding;

- Maturity Index.

The total number of nematodes and taxonomic diversity gives a first (rough) indication of the ecological condition of a soil type. Enrichment (eutrophication) can be recognized by high numbers, often with the dominance of a few opportunistic species. Pollution and very harsh abiotic conditions cause low nematode abundance, but can coincide with a diverse fauna.

The Maturity Index, proportion of cp-classes and feeding groups give good insight into processes and disturbance in the soil ecosystem. Bacterial and fungal dominated decomposition routes in the soil can be recognized as well as mature soil ecosystems and excessive manuring or nutrient exhaustion. These integrated indicators are more stable and robust due to the higher level of organization that is represented.

Knowledge about the soil-inhabiting nematodes has emerged to such a level that habitat-response models can be made for the chance of occurrence in relation to abiotic factors [13]. In the near future, it will be possible to use this for prognostic purposes. However, these ecological applications are based on systematic and reliable monitoring data. Field observations contain a certain amount of natural variation. The level of variation in an ecosystem-type depends on temporal and geographical factors and human influence. For bio-classification, it is important to know the variance around the ecological characteristic. Therefore, sufficient replicates of a certain habitat type (10 to 20) should be present in a monitoring system, if necessary with geographical/geological categories or differentiation. The definition of ecological indicator values in an original or undisturbed situation opens the possibility of ecological soil quality assessment.

8 Study report

The study report shall include the following information:

- reference to this part of ISO 23611 (i.e. ISO 23611-4);
- full description of the experiment design and procedures (extraction method, e.g. Oostenbrink elutriator);
- description and characterization of the study site (especially soil properties);
- sampling method with specification of corer type, number of samples, and sampled area;
- description of the sampling conditions, including date and duration of sampling in the field and climatic parameters, e.g. air temperature;
- details of fixation and preservation of the biological material;
- values recalculated to different units (fresh-weight, dry-weight and area);
- discussion of the results;
- spreadsheet or database file with raw data and calculations;
- all information, including measured raw data and all problems which might have occurred during all phases of the study.

Annex A (informative)

Figures of equipment and methods for nematological research



NOTE Pictures taken by A.J. Schouten RIVM, NL.

Figure A.1 — Grass plot corer in action

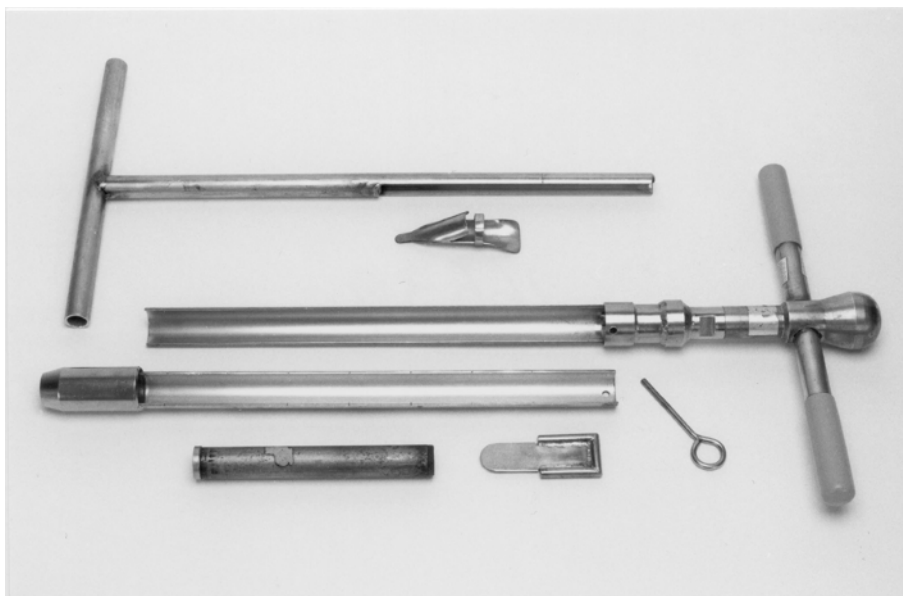

NOTE Augers are still generally used in soil science and sampling of agricultural soils.

Figure A.2 — Soil auger (top) and split-tube corer



Figure A.3 —Oostenbrink elutriator ¹⁾ (model III)



Figure A.4 — Extraction sieve with filters, clamping ring and dish



Figure A.5 — Automated Oostenbrink funnel for routine analysis (left), extraction sieves with filters (middle) and rack with extraction dishes (right)



Figure A.6 — Counting (left) and identifying nematodes in a laboratory

References [14], [22] and [23] give several schematic drawings and measurements of the apparatus (see also Figures B.1 and B.2). On the basis of this information, it can be built at an engineering workshop. Reference [1] also describes the stepwise use of the Oostenbrink funnel in a manual for practical work in nematology.

The Oostenbrink elutriator ¹⁾ is also commercially available. It is not a standard product in the catalogue, but is built to order as a complete set. Separate parts are also available. The elutriator can be ordered on article number AA.65.21.31.1.

Cotton-wool filters are, for instance, available from NIFA INSTRUMENTEN B.V., Leeuwarden, the Netherlands.²⁾

2) This information is given for the convenience of users of this document and does not constitute an endorsement by ISO of this product. Equivalent products may be used if they can be shown to lead to the same results.

Annex B
(informative)

Information about the availability of the Oostenbrink elutriator

Dimensions in centimetres

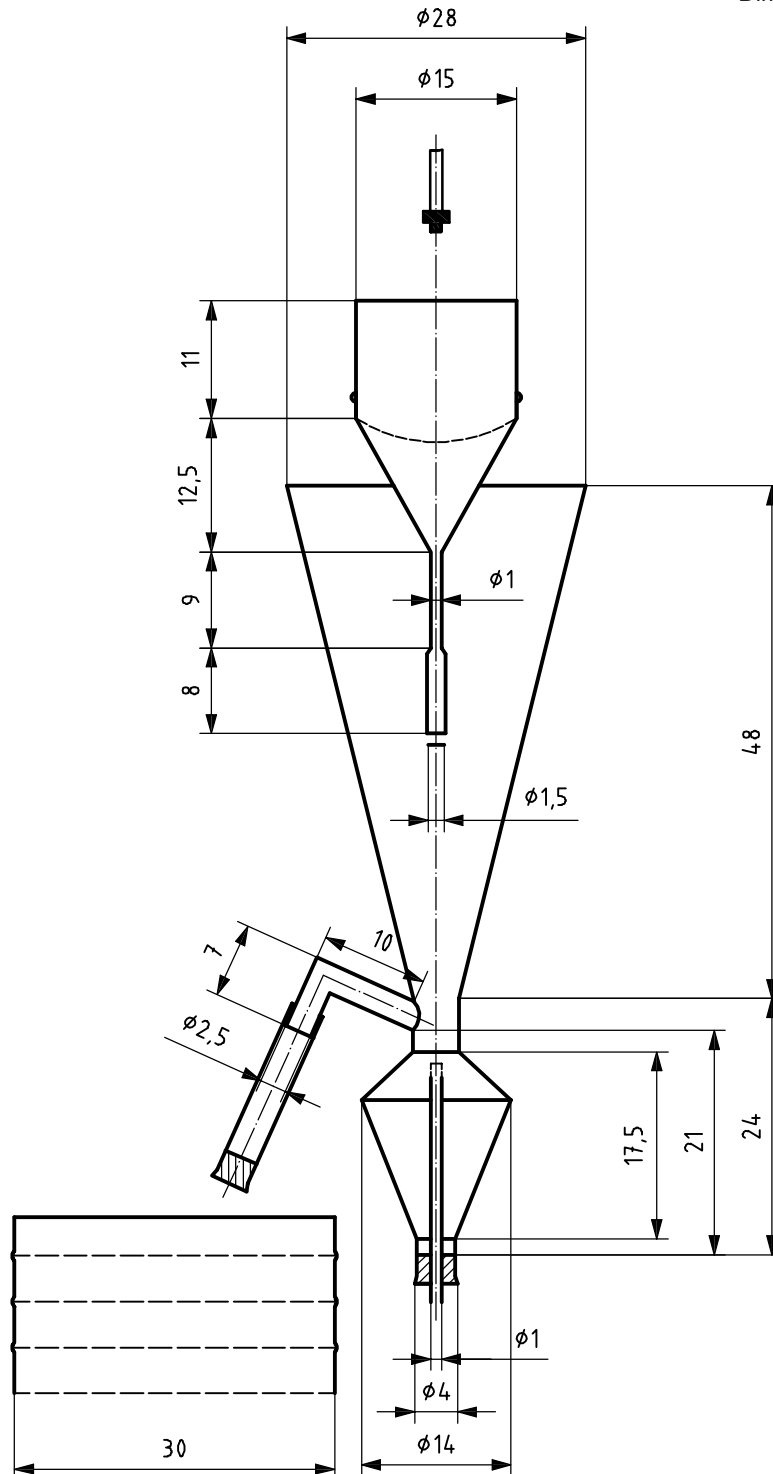

NOTE Drawing based on Reference [22].

Figure B.1 — Drawing showing the dimensions of the Oostenbrink elutriator ¹⁾

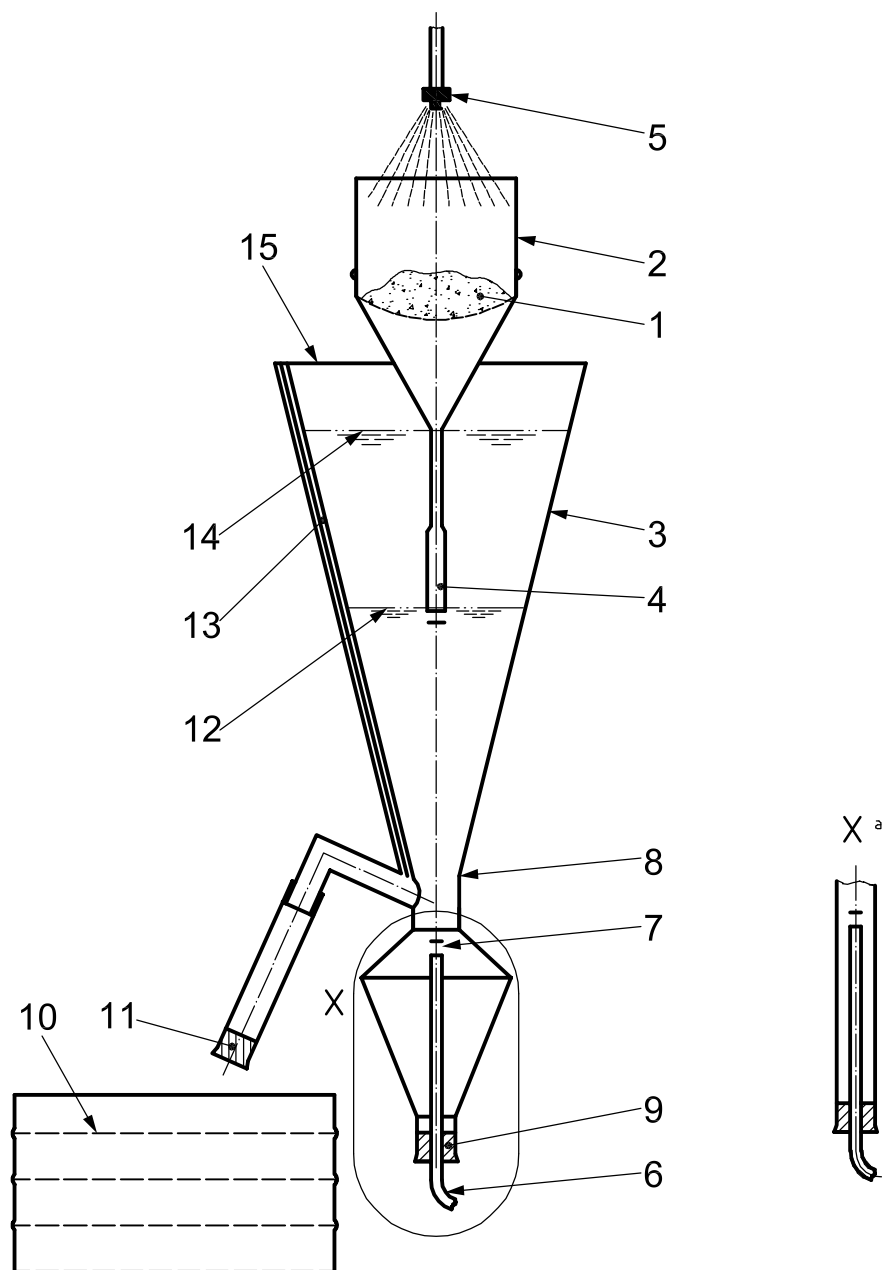

Key

- | | | | |
|---|---|----|--|
| 1 | sample of moist soil | 9 | rubber plug which can be removed for flushing the apparatus |
| 2 | 1-mm top sieve | 10 | nest of sieves |
| 3 | flotation apparatus | 11 | rubber plug of the outlet |
| 4 | funnel pipe, with baffle plate | 12 | water level at start |
| 5 | nozzle, of about 700 ml/min of water | 13 | plastic gauge glass |
| 6 | upward water current coming from a reservoir tank near the ceiling of the room and adjusted through a turbo meter | 14 | water level when the nozzle (5) is closed and the upward current is adjusted to 400 ml/min |
| 7 | insertion pipe with perforated tip | 15 | water level when plug (11) is pulled out |
| 8 | neck of the apparatus where the nematodes are stemmed | | |

NOTE 1 Detail X is shown for large samples.
Detail X^a shows an apparatus for normal samples.

NOTE 2 Drawing based on Reference [14].

Figure B.2 — Flotation apparatus III (extraction of active nematodes from soil)

Annex C (informative)

Information about the Baermann funnel/tray extraction method

Baermann funnel/tray extraction without prior soil elutriation is still a popular method worldwide (see references [40], [41], [43], [45], [47], [49] and [50]). Usually free-living nematodes do not have cysts or inactive stages, so Baermann funnel/tray extraction is effective to obtain the nematodes, although the extraction efficiency may differ between nematode taxa, as is often the case with any type of extraction method [44]. One of the advantages of Baermann extraction is that the nematode suspension obtained includes few or no debris which hinder seriously nematode identification. More importantly, the method is simple, inexpensive and less laborious to operate, which makes it available worldwide. Soil elutriation prior to the extraction is optional.

The principle of the basic Baermann funnel method is shown in Figure C.1. A soil sample or organic material is folded in a piece of cloth, which is submersed in a water-filled funnel. The nematodes crawl out of the soil into the water and settle in the closed stem of the funnel. They are collected after two days or three days.

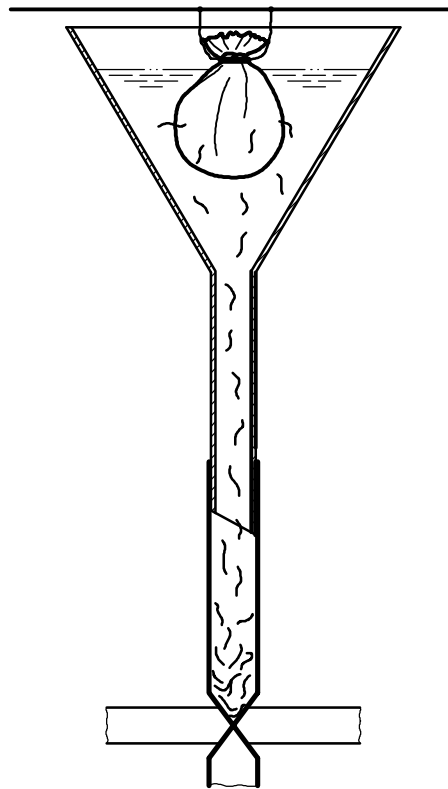

Figure C.1 — Schematic drawing of a Baermann funnel

There are several modifications on the basic Baermann funnel method to enhance the extraction efficiency. The main improvement is the use of a supporting sieve or wire-mesh basket to spread out the sample on a cheese cloth (cotton disc) or tissue paper. It enlarges the contact surface between the soil sample and water in the funnel. Additionally, the funnels can be heated from above for some time by electric bulbs or a heating plate to force the nematodes downwards.

BS EN ISO 23611-4:2011
EN ISO 23611-4:2011 (E)

The extraction efficiency is influenced by several factors, such as

- amount of soil used,
- previous storage of samples,
- incubation temperature,
- type of filter,
- extraction time.

Figures about the recovery levels reported in literature vary between 12 % and 90 % [14],[46]. The highest recovery is obtained with the Baermann funnel when small quantities of soil are used for nematode extraction.

Comparative studies on the Oostenbrink elutriation and Baermann funnel technique are scarce. Oostenbrink [14] gives results of different methods including two variants of the Baermann funnel. The main advantage of the Oostenbrink elutriation is that larger samples of 100 g up to 1 000 g can be extracted without significant influence on the efficiency or clearness of the suspensions. Therefore, it is less sensitive for heterogeneity of nematode distributions in the soil. The Oostenbrink method is practical for routine analysis of larger sample series (such as in biomonitoring programmes) and is therefore used in several contract laboratories.

Bibliography

- [1] S' JACOB, J.J. and VAN BEZOOIJEN, J. *A manual for practical work in Nematology. Praktikumhandleiding vakgroep Nematologie*. Landbouwwuniversiteit Wageningen, 1986
- [2] ANDRASSY, I. *Klasse Nematoda*. Gustav Fischer Verlag, Stuttgart, 1984
- [3] BONGERS, T. *De nematoden van Nederland*. Stichting Uitgeverij Koninklijke Nederlandse Natuurhistorische Vereniging. Uitgeverij Pirola, Schoorl, 1988
- [4] BONGERS, T. The Maturity Index: an ecological measure of environmental disturbance based on nematode species composition. *Oecologia*, **83**, 1990, pp. 14-19
- [5] BONGERS, T. The Maturity Index, the evolution of nematode life history traits, adaptive radiation and cp-scaling. *Plant and Soil*, **212**, 1999, pp 13-22
- [6] BRZESKI, M.W. *Nematodes of Tylenchina in Poland and temperate Europe*. Muzeum I Instytut Zoologii Polska Akademia Nauk Warszawa, 1998
- [7] DECRAEMER, W. *The family Trichodoridae: stubby root and virus vector nematodes*. Kluwer Academic Publishers, Dordrecht/Boston/London, 1995
- [8] GOODEY, J.B. *Soil and freshwater nematodes*. Methuen & Co LTD London, 1963
- [9] GRAEFE, U. and SCHMELZ, R.M. Indicator values, strategy types and life forms of terrestrial Enchytraeidae and other microannelids. *Newsletter Enchytraeidae*, **6**, 1999, pp. 59-67
- [10] HEEB, J. and VETTER, F. *Ansatz für eine integrative Auswertung bodenbiologischer Messergebnisse*. Umweltmaterialien. BUWAL (ed.), Schattweid, Switzerland, 1995
- [11] JAIRAJPURI, M.S. and AHMAD, W. *Dorylaimida. Free-living, predaceous and plant-parasitic nematodes*. E.J. Brill, Leiden, 1992
- [12] MARKERT, B.A., BREURE, A.M. and ZECHMEISTER, H.G. *Bioindicators & Biomonitoring. Principles, Concepts and Applications*. Elsevier Science Ltd., Oxford, 2003
- [13] MULDER, Ch., DE ZWART, D., VAN WIJNEN, H.J., SCHOUTEN, A.J. and BREURE, A.M. Observational and simulated evidence of ecological shifts within the soil nematode community of agroecosystems under conventional and organic farming. *Functional Ecology*, **17**, 2003, pp. 516-525
- [14] OOSTENBRINK, M. Estimating nematode populations by some selected methods. In: *Nematology* (ed. Sasser, J.N. and Jenkins, W.R.), University of North Carolina Press, Chapel Hill, 1960, pp. 85-102
- [15] RÖMBKE, J., BECK, L., FÖRSTER, B., FRÜND, H-C., HORAK, F., RUF, A., ROSCICZEWSKI, C., SCHEURIG, M. and WOAS, S. *Boden als Lebensraum für Bodenorganismen — Literaturstudie*. Texte und Berichte zum Bodenschutz Nr. 4/97, Landesanstalt für Umweltschutz Baden-Württemberg, Karlsruhe, 1997, 437 pp.
- [16] SCHOUTEN, A.J. Recovery of nematodes from Scots pine soil and litter bulk samples: effects of mixing and addition of water. *Pedobiologia*, **39**, 1995, pp. 277-288
- [17] SCHOUTEN, A.J., BREURE, A.M., BLOEM, J., DIDDEN, W., DE RUITER, P.C. and SIEPEL, H. *Life support functies van de bodem: operationalisering t.b.v. het biodiversiteitsbeleid*. RIVM Report 607601003, 1999, 55 pp
- [18] SCHOUTEN, A.J. and ARP, K.K.M. A comparative study on the efficiency of extraction methods for nematodes from different forest litters. *Pedobiologia*, **35**, 1991, pp. 393-400

BS EN ISO 23611-4:2011
EN ISO 23611-4:2011 (E)

- [19] SEINHORST, J.W. The quantitative extraction of nematodes from soil. *Nematologica*, **1**, 1956, pp. 249-267
- [20] SEINHORST, J.W. Modifications of the elutriation method for extraction nematodes from soil. *Nematologica*, **8**, 1962, pp. 117-128
- [21] SIDDIQI, M.R. *Tylenchida, Parasites of Plants and Insects*, 2nd edn., Commonwealth Agricultural Bureaux, Slough, UK, 2000
- [22] SOUTHEY, J.F. *Laboratory methods for work with plant and soil nematodes*. Her Majesty's Stationary Office, London, 1970
- [23] SOUTHEY, J.F. *Laboratory methods for work with plant and soil nematodes*. Reference Book 402. Her Majesty's Stationary Office, London, 1986
- [24] SPURGEON, D.J., SANDIFER, R.D. and HOPKIN, S.P. The use of macro-invertebrates for population and community monitoring of metal contamination — indicator taxa, effect parameters and the need for a soil invertebrate prediction and classification scheme (SIVPACS). In: *Bioindicator Systems for Soil Pollution* (eds. Van Straalen, N.M. and Krivolutsky, D.A.), Kluwer Academic Publ., Dordrecht., 1996, pp. 95-109
- [25] VERSCHOOR, B.C. and DE GOEDE, R.G.M. The nematode extraction efficiency of the Oostenbrink elutriator-cottonwool filter method with special reference to nematode body size and life strategy. *Nematology*, **2**(3), 2000, pp. 325-342
- [26] WEEKS, J.M., HOPKIN, S.P., WRIGHT, J.F., BLACK, H., EVERS HAM, B.C., ROY, D. and SVENDSEN, C. *A Demonstration of the Feasibility of SOILPACS*. Final Report HMIP/CPR2/41/1/247. 1997, 180 pp.
- [27] YEATES, G.W., BONGERS, T., DE GOEDE, R.M.G., FRECKMAN, D.W. and GEORGIEVA, S.S. Feeding habitats in soil nematode families and genera. An outline for soil ecologists. *Journal of Nematology*, **25**, 1993, pp. 315-331
- [28] YEATES, G.W. Nematodes as soil indicators: functional and biodiversity aspects. *Biology and Fertility of Soils*, **37**, 2003, pp. 199-210
- [29] ISO 10381-1:2002, *Soil quality — Sampling — Part 1: Guidance on the design of sampling programmes*
- [30] ISO 10381-6:—³, *Soil quality — Sampling — Part 6: Guidance on the collection, handling and storage of soil under aerobic conditions for the assessment of microbiological processes, biomass and diversity in the laboratory*
- [31] ISO 10390:2005, *Soil quality — Determination of pH*
- [32] ISO 10694:1995, *Soil quality — Determination of organic and total carbon after dry combustion (elementary analysis)*
- [33] ISO 11268-3:1999, *Soil quality — Effects of pollutants on earthworms — Part 3: Guidance on the determination of effects in field situations*
- [34] ISO 11272:1998, *Soil quality — Determination of dry bulk density*
- [35] ISO 11274:1998, *Soil quality — Determination of the water-retention characteristic — Laboratory methods*

3) To be published. (Revision of ISO 10381-6:1993)

- [36] ISO 11277:1998, *Soil quality — Determination of particle size distribution in mineral soil material — Method by sieving and sedimentation*
- [37] ISO 11461:2001, *Soil quality — Determination of soil water content as a volume fraction using coring sleeves — Gravimetric method*
- [38] ISO 11465:1993, *Soil quality — Determination of dry matter and water content on a mass basis — Gravimetric method*

Additional references for further information:

- [39] BARKER, K.R. and NUSBAUM, C.J. Diagnostic and advisory programs. In: *Plant parasitic nematodes. Vol. 1* (eds. Zuckerman, B.M. and Rohde, R.A.), New York, Academic Press, 1971, pp. 281-301
- [40] FORGE, T. A. and SIMARD, S. W. Structure of nematode communities in forest soils of southern British Columbia: relationships to nitrogen mineralization and effects of clearcut harvesting and fertilization. *Biology and Fertility of Soils*, **34** (3), 2001, pp. 170-178
- [41] FU, ShengLei, COLEMAN, D.C., HENDRIX, P.F. and CROSSLEY, D. A., Jr. Responses of trophic groups of soil nematodes to residue application under conventional tillage and no-till regimes. *Soil Biology & Biochemistry*, **32** (11/12), 2000, pp. 1731-1741
- [42] HANEL, L. (2001) Succession of soil nematodes in pine forests on coal-mining sands near Cottbus, Germany. *Applied Soil Ecology*, **16** (1), 2001, pp. 23-34
- [43] HOSCHITZ, M. and KAUFMANN, R. Nematode community composition in five alpine habitats. *Nematology*, **6** (5), 2004, pp. 737-747
- [44] MCSORLEY, R. and FREDERICK, J. J. Effect of extraction method on perceived composition of the soil nematode community. *Applied Soil Ecology*, **27**(1), 2004, pp. 55-63
- [45] OKADA, H., HARADA, H. and KADOTA, I. Application of diversity indices and ecological indices to evaluate nematode community changes after soil fumigation. *Japanese Journal of Nematology*, **34** (2), 2004, pp. 89-98
- [46] RUESS, L. Studies on the nematode fauna of an acid forest soil: spatial distribution and extraction. *Nematologica*, **41**, 1995, pp. 229-239
- [47] RUESS, L., SCHMIDT, I. K., MICHELSEN, A. and JONASSON, S. Manipulations of a microbial based soil food web at two arctic sites — evidence of species redundancy among the nematode fauna? *Applied Soil Ecology*, **17** (1), 2001, pp. 19-30
- [48] SEINHORST, J.W. A rapid method for the transfer of nematodes from fixative to anhydrous glycerin. *Nematologica*, **14**, 1959, pp. 67-69
- [49] SOHLENIUS, B. Influence of clear-cutting and forest age on the nematode fauna in a Swedish pine forest soil. *Applied Soil Ecology*, **19** (3), 2002, pp. 261-277
- [50] YEATES, G.W., WARDLE, D.A. and WATSON, R.N. Responses of soil nematode populations, community structure, diversity and temporal variability to agricultural intensification over a seven-year period. *Soil Biology & Biochemistry*, **31** (12), 1999, pp. 1721-1733

BSI - British Standards Institution

BSI is the independent national body responsible for preparing British Standards. It presents the UK view on standards in Europe and at the international level. It is incorporated by Royal Charter.

Revisions

British Standards are updated by amendment or revision. Users of British Standards should make sure that they possess the latest amendments or editions.

It is the constant aim of BSI to improve the quality of our products and services. We would be grateful if anyone finding an inaccuracy or ambiguity while using this British Standard would inform the Secretary of the technical committee responsible, the identity of which can be found on the inside front cover. Tel: +44 (0)20 8996 9000. Fax: +44 (0)20 8996 7400.

BSI offers members an individual updating service called PLUS which ensures that subscribers automatically receive the latest editions of standards.

Buying standards

Orders for all BSI, international and foreign standards publications should be addressed to Customer Services. Tel: +44 (0)20 8996 9001. Fax: +44 (0)20 8996 7001 Email: orders@bsigroup.com You may also buy directly using a debit/credit card from the BSI Shop on the Website <http://www.bsigroup.com/shop>

In response to orders for international standards, it is BSI policy to supply the BSI implementation of those that have been published as British Standards, unless otherwise requested.

Information on standards

BSI provides a wide range of information on national, European and international standards through its Library and its Technical Help to Exporters Service. Various BSI electronic information services are also available which give details on all its products and services. Contact Information Centre. Tel: +44 (0)20 8996 7111 Fax: +44 (0)20 8996 7048 Email: info@bsigroup.com

Subscribing members of BSI are kept up to date with standards developments and receive substantial discounts on the purchase price of standards. For details of these and other benefits contact Membership Administration. Tel: +44 (0)20 8996 7002 Fax: +44 (0)20 8996 7001 Email: membership@bsigroup.com

Information regarding online access to British Standards via British Standards Online can be found at <http://www.bsigroup.com/BSOL>

Further information about BSI is available on the BSI website at <http://www.bsigroup.com>

Copyright

Copyright subsists in all BSI publications. BSI also holds the copyright, in the UK, of the publications of the international standardization bodies. Except as permitted under the Copyright, Designs and Patents Act 1988 no extract may be reproduced, stored in a retrieval system or transmitted in any form or by any means – electronic, photocopying, recording or otherwise – without prior written permission from BSI.

This does not preclude the free use, in the course of implementing the standard, of necessary details such as symbols, and size, type or grade designations. If these details are to be used for any other purpose than implementation then the prior written permission of BSI must be obtained.

Details and advice can be obtained from the Copyright and Licensing Manager. Tel: +44 (0)20 8996 7070 Email: copyright@bsigroup.com