

BS EN ISO 22868:2011



BSI Standards Publication

**Forestry and garden machinery
— Noise test code for portable
hand-held machines with
internal combustion engine —
Engineering method (Grade 2
accuracy) (ISO 22868:2011)**

bsi.

...making excellence a habit.™

National foreword

This British Standard is the UK implementation of EN ISO 22868:2011. It supersedes BS EN ISO 22868:2008 which is withdrawn.

The UK participation in its preparation was entrusted to Technical Committee AGE/29, Forestry machinery.

A list of organizations represented on this committee can be obtained on request to its secretary.

This publication does not purport to include all the necessary provisions of a contract. Users are responsible for its correct application.

© BSI 2011

ISBN 978 0 580 73946 0

ICS 13.140; 17.140.20; 65.060.80

Compliance with a British Standard cannot confer immunity from legal obligations.

This British Standard was published under the authority of the Standards Policy and Strategy Committee on 31 May 2011.

Amendments issued since publication

Date	Text affected
------	---------------

EUROPEAN STANDARD

EN ISO 22868

NORME EUROPÉENNE

EUROPÄISCHE NORM

March 2011

ICS 17.140.20; 65.060.80; 13.140

Supersedes EN ISO 22868:2008

English Version

**Forestry and garden machinery - Noise test code for portable
hand-held machines with internal combustion engine -
Engineering method (Grade 2 accuracy) (ISO 22868:2011)**

Machines forestières et machines de jardin - Code d'essai
acoustique pour machines portatives tenues à la main à
moteur à combustion interne - Méthode d'expertise (classe
de précision 2) (ISO 22868:2011)

Forst- und Gartenmaschinen - Geräuschnorm für
handgehaltene Maschinen mit Verbrennungsmotor -
Verfahren der Genauigkeitsklasse 2 (ISO 22868:2011)

This European Standard was approved by CEN on 15 January 2011.

CEN members are bound to comply with the CEN/CENELEC Internal Regulations which stipulate the conditions for giving this European Standard the status of a national standard without any alteration. Up-to-date lists and bibliographical references concerning such national standards may be obtained on application to the CEN-CENELEC Management Centre or to any CEN member.

This European Standard exists in three official versions (English, French, German). A version in any other language made by translation under the responsibility of a CEN member into its own language and notified to the CEN-CENELEC Management Centre has the same status as the official versions.

CEN members are the national standards bodies of Austria, Belgium, Bulgaria, Croatia, Cyprus, Czech Republic, Denmark, Estonia, Finland, France, Germany, Greece, Hungary, Iceland, Ireland, Italy, Latvia, Lithuania, Luxembourg, Malta, Netherlands, Norway, Poland, Portugal, Romania, Slovakia, Slovenia, Spain, Sweden, Switzerland and United Kingdom.



EUROPEAN COMMITTEE FOR STANDARDIZATION
COMITÉ EUROPÉEN DE NORMALISATION
EUROPÄISCHES KOMITEE FÜR NORMUNG

Management Centre: Avenue Marnix 17, B-1000 Brussels

Foreword

This document (EN ISO 22868:2011) has been prepared by Technical Committee ISO/TC 23 "Tractors and machinery for agriculture and forestry" in collaboration with Technical Committee CEN/TC 144 "Tractors and machinery for agriculture and forestry" the secretariat of which is held by AFNOR.

This European Standard shall be given the status of a national standard, either by publication of an identical text or by endorsement, at the latest by September 2011, and conflicting national standards shall be withdrawn at the latest by September 2011.

Attention is drawn to the possibility that some of the elements of this document may be the subject of patent rights. CEN [and/or CENELEC] shall not be held responsible for identifying any or all such patent rights.

This document supersedes EN ISO 22868:2008.

This document has been prepared under a mandate given to CEN by the European Commission and the European Free Trade Association, and supports essential requirements of EU Directive(s).

For relationship with EU Directive, see informative Annex ZA, which is an integral part of this document.

According to the CEN/CENELEC Internal Regulations, the national standards organizations of the following countries are bound to implement this European Standard: Austria, Belgium, Bulgaria, Croatia, Cyprus, Czech Republic, Denmark, Estonia, Finland, France, Germany, Greece, Hungary, Iceland, Ireland, Italy, Latvia, Lithuania, Luxembourg, Malta, Netherlands, Norway, Poland, Portugal, Romania, Slovakia, Slovenia, Spain, Sweden, Switzerland and the United Kingdom.

Endorsement notice

The text of ISO 22868:2011 has been approved by CEN as a EN ISO 22868:2011 without any modification.

Annex ZA (informative)

Relationship between this European Standard and the Essential Requirements of EU Directive 2006/42/EC

This European Standard has been prepared under a mandate given to CEN by the European Commission and the European Free Trade Association to provide one means of conforming to Essential Requirements of the New Approach Directive 2006/42/EC on machinery.

Once this standard is cited in the Official Journal of the European Union under that Directive and has been implemented as a national standard in at least one Member State, compliance with the normative clauses of this standard confers, within the limits of the scope of this standard, a presumption of conformity with the Essential Requirement 1.7.4.2 u) of that Directive and associated EFTA regulations.

WARNING — Other requirements and other EU Directives may be applicable to the product(s) falling within the scope of this standard.

Contents

Page

Foreword	iv
Introduction.....	v
1 Scope	1
2 Normative references	1
3 Terms and definitions	2
4 Quantities to be measured and quantities to be determined.....	2
5 A-weighted sound power level determination.....	2
6 A-weighted emission sound pressure level measurement at the operator position	3
7 Testing and operating conditions.....	4
8 Information to be reported.....	5
9 Declaration and verification of noise emission values	8
Annex A (normative) Specific conditions for chain saws	10
Annex B (normative) Specific conditions for brush cutters and grass-trimmers.....	14
Annex C (normative) Specific conditions for pole-mounted powered pruners	19
Annex D (normative) Specific conditions for hedge-trimmers	23
Annex E (normative) Specific conditions for garden blower/vacuum	27
Annex F (informative) Example of water brake mounted on chain saw bar to simulate cutting	32
Annex G (informative) Summary of results from round robin tests 2007/2008 on single chain saw, brush saw and grass-trimmer	34
Annex H (informative) A-weighted sound power level declaration according to the EU Directive on noise emission in the environment by equipment for use outdoors, 2000/14/EC.....	35

Foreword

ISO (the International Organization for Standardization) is a worldwide federation of national standards bodies (ISO member bodies). The work of preparing International Standards is normally carried out through ISO technical committees. Each member body interested in a subject for which a technical committee has been established has the right to be represented on that committee. International organizations, governmental and non-governmental, in liaison with ISO, also take part in the work. ISO collaborates closely with the International Electrotechnical Commission (IEC) on all matters of electrotechnical standardization.

International Standards are drafted in accordance with the rules given in the ISO/IEC Directives, Part 2.

The main task of technical committees is to prepare International Standards. Draft International Standards adopted by the technical committees are circulated to the member bodies for voting. Publication as an International Standard requires approval by at least 75 % of the member bodies casting a vote.

Attention is drawn to the possibility that some of the elements of this document may be the subject of patent rights. ISO shall not be held responsible for identifying any or all such patent rights.

ISO 22868 was prepared by Technical Committee ISO/TC 23, *Tractors and machinery for agriculture and forestry*, Subcommittee SC 17, *Manually portable forest machinery*.

This second edition cancels and replaces the first edition (ISO 22868:2005), which has been technically revised. It now also deals with pole-mounted powered pruners, hedge-trimmers and garden blowers/vacuums.

Introduction

This document is a type-C standard as stated in ISO 12100.¹⁾

The machinery concerned and the extent to which hazards, hazardous situations or hazardous events are covered are indicated in the Scope of this document.

When requirements of this type-C standard are different from those which are stated in type-A or B standards, the requirements of this type-C standard take precedence over the requirements of the other standards for machines that have been designed and built according to the requirements of this type-C standard.

During the first steps in the preparation of this International Standard it became obvious that the repeatability of the test results could become better if the operator were to be replaced by a simulation process, representing the normal operating modes with chain-saws and trimmers/brush-cutters. Furthermore, it was found that the cutting process performed with chain-saws causes considerable deviations, which are not related to the measured object but to the test procedure itself.

Based on these observations, it was concluded that the operators in both test procedures, i.e. for chain-saws and trimmers/brush-cutters, ought to be replaced by a defined fixture and the cutting process with chain-saws by a brake simulating the load. In this manner, the operating conditions during measurement would simulate normal operating conditions.

The determination of noise emission characteristics is primarily intended for

- manufacturers' declarations of noise emitted,
- comparing the noise emitted by machines in the family concerned, and
- purposes of noise control at source at the design stage.

The use of this noise test code will ensure reproducibility of the determination of the noise emission characteristics within specified limits determined by the grade of accuracy of the basic noise measurement method used. Noise measurement methods allowed by this International Standard give results with Grade 2 accuracy.

The operating modes specified for the tests are consistent with those involved in the assessment of the exposure sound pressure levels, for example, over a typical working day.

NOTE Exposure sound pressure levels are the mean sound pressure levels experienced by the operator over a defined period of time.

The work cycles chosen for this test code are based on the following considerations of application:

- a) chain-saws with an engine of $< 80 \text{ cm}^3$ are used for various operations, including felling, bucking and delimiting;
- b) chain-saws with an engine of $\geq 80 \text{ cm}^3$ are normally used for felling and bucking.

Delimiting will cause the saw to run at racing speed; therefore, racing is included only for saws with a $< 80 \text{ cm}^3$ engine.

1) *Safety of machinery — General principles for design — Risk assessment and risk reduction.*

For brush-cutters, grass-trimmers, hedge-trimmers and pole-mounted powered pruners, the cutting mode (full load) is estimated to be valid only for short periods, while racing and idling are the two dominant modes. Moreover, it has also been found to be diverse and not able to be performed under repeatable conditions.

For trimmers, the full load and the racing modes are integrated in one single mode due to the loading effect of the flexible line.

For brush-cutters, hedge-trimmers and pole-mounted powered pruners, it is not possible to simulate the full load mode in a feasible way since there are no constant load conditions comparable to chain-saws. Since the operating mode "racing" is anyhow the worst case, it is used as representative.

For garden blowers, full load and idling are the two dominant modes.

In either case, transport and other tasks between operations will cause the machine to run at idling. Experience has led to the conclusion that, except for hedge-trimmers and blowers, equal duration for the different working modes is a good estimation of daily exposure.

For hedge-trimmers, experience has shown that the machine is used 1/5 at idling and 4/5 at racing, while for garden blowers it is used 1/7 at idling and 6/7 at racing.

A summary of results from "round robin" tests, carried out between 2007 and 2008 in up to eight test laboratories on a single chain-saw, brush-saw and grass-trimmer, is given in Annex G.

Forestry and gardening machinery — Noise test code for portable hand-held machines with internal combustion engine — Engineering method (Grade 2 accuracy)

CAUTION — Some of the test procedures specified in this International Standard involve processes that could lead to a hazardous situation. Any person performing tests in accordance with this International Standard shall be appropriately trained in the type of work to be carried out.

1 Scope

This International Standard specifies a noise test code for determining, efficiently and under standardized conditions, the noise emission characteristics of portable, hand-held, combustion-engine-powered forest and garden machines, including chain-saws, brush-cutters, grass-trimmers, pole-mounted powered pruners, hedge-trimmers and garden blowers/vacuums. Noise emission characteristics include the A-weighted emission sound pressure level at the operator position and the A-weighted sound power level.

2 Normative references

The following referenced documents are indispensable for the application of this document. For dated references, only the edition cited applies. For undated references, the latest edition of the referenced document (including any amendments) applies.

ISO 354, *Acoustics — Measurement of sound absorption in a reverberation room*

ISO 3744, *Acoustics — Determination of sound power levels and sound energy levels of noise sources using sound pressure — Engineering methods for an essentially free field over a reflecting plane*

ISO 4871:1996, *Acoustics — Declaration and verification of noise emission values of machinery and equipment*

ISO 6531, *Machinery for forestry — Portable chain-saws — Vocabulary*

ISO 7112, *Machinery for forestry — Portable brush-cutters and grass-trimmers — Vocabulary*

ISO 7293, *Forestry machinery — Portable chain saws — Engine performance and fuel consumption*

ISO 8893, *Forestry machinery — Portable brush-cutters and grass-trimmers — Engine performance and fuel consumption*

ISO 11201, *Acoustics — Noise emitted by machinery and equipment — Determination of emission sound pressure levels at a work station and at other specified positions in an essentially free field over a reflecting plane with negligible environmental corrections*

IEC 61672-1, *Electroacoustics — Sound level meters — Part 1: Specifications*

3 Terms and definitions

For the purposes of this document, the terms and definitions given in ISO 6531 and ISO 7112 apply.

4 Quantities to be measured and quantities to be determined

The quantities to be measured are the time-averaged sound pressure levels defined in the relevant basic noise measurement standards (ISO 3744, ISO 11201), A-weighted and — if required — in frequency bands.

The quantities to be determined are the sound power levels and the emission sound pressure levels, A-weighted and — if required — in frequency bands.

5 A-weighted sound power level determination

For the determination of the A-weighted sound power level, ISO 3744 shall be used, subject to the following modifications or additions.

- a) The microphone array shall be six microphone positions, in accordance with Figure 1 and Table 1.

NOTE 1 The six-microphone array is permitted because experimental data have shown that use of this array does not yield results that differ significantly from those obtained with the 10-microphone array specified in ISO 3744.

- b) The measurement surface shall be a hemisphere with a radius, r , of $\geq 2d_0$, preferably 4 m; d_0 is determined by the reference box and its defined location above ground, see Figure 1. If a bigger radius is needed it shall be chosen from 6 m, 8 m and 10 m. A smaller radius is permitted if it is demonstrated that the results are within 0,5 dB compared with measurements with a hemisphere of $r = 4$ m.

NOTE 2 The smaller radius could be necessary in an anechoic room where a radius of 4 m cannot be provided.

- c) The conditions for the particular type of machine to be tested and its mounting and orientation shall be according to the corresponding annex of this International Standard.
- d) Environmental conditions shall be within the limits specified by the manufacturer of the measuring equipment. The ambient air temperature shall be in the range -10 °C to 30 °C and the wind speed shall be less than 5 m/s. A microphone windscreen shall be used whenever the wind speed exceeds 1 m/s.
- e) Measurements shall be made using an integrating-averaging sound level meter as defined in IEC 61672-1; alternatively, instruments with the time-weighting characteristics “slow”, as defined in IEC 61672-1, may be used.
- f) The value of K_{2A} , determined in accordance with ISO 3744:2010, Annex A, shall at maximum be 2 dB.

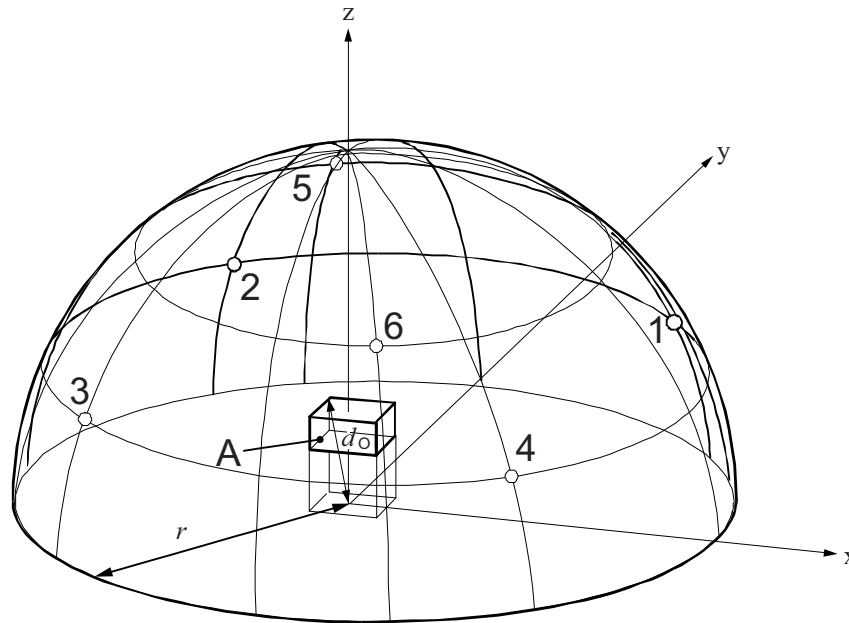

Key

- A reference box
- d_0 characteristic source dimension
- r hemisphere radius $\geq 2d_0$

Figure 1 — Microphone positions on hemisphere

Table 1 — Coordinates of microphone positions

Position no.	Coordinate		
	x	y	z
1	$+0,65 r$	$+0,65 r$	$0,38 r$
2	$-0,65 r$	$+0,65 r$	$0,38 r$
3	$-0,65 r$	$-0,65 r$	$0,38 r$
4	$+0,65 r$	$-0,65 r$	$0,38 r$
5	$-0,28 r$	$+0,65 r$	$0,71 r$
6	$+0,28 r$	$-0,65 r$	$0,71 r$

NOTE See also Annex H concerning the microphone positions.

6 A-weighted emission sound pressure level measurement at the operator position

6.1 General

For the measurement of the A-weighted emission sound pressure level, ISO 11201 shall be used, subject to the following modifications and additions.

- a) The conditions for the particular type of machine to be tested and its mounting shall be in accordance with the corresponding annex of this International Standard.

- b) The surface shall comply with the provisions of either 6.2 or 6.3. Reproducibility of results using natural grass or other organic material is likely to be worse than that required for Grade 2 of accuracy. In case of dispute, measurements shall be carried out in the open air and on the artificial surface (see 6.2).
- c) Environmental conditions shall be within the limits specified for the measuring equipment. The ambient air temperature shall be in the range $-10\text{ }^{\circ}\text{C}$ to $30\text{ }^{\circ}\text{C}$, and the wind speed shall be less than 5 m/s. A microphone windscreen shall be used whenever the wind speed exceeds 1 m/s.
- d) Measurements shall be made using an integrating-averaging sound level meter as defined in IEC 61672-1; alternatively, instruments with the time-weighting characteristics “slow”, as defined in IEC 61672-1, may be used.
- e) The location of a particular type of machinery respective to the microphone array shall be in accordance with the corresponding annex of this International Standard.

6.2 Requirements for artificial surface

The artificial surface shall have absorption coefficients in accordance with Table 2, measured according to ISO 354.

Table 2 — Absorption coefficient

Frequencies Hz	Absorption coefficients	Tolerance
125	0,1	$\pm 0,1$
250	0,3	$\pm 0,1$
500	0,5	$\pm 0,1$
1 000	0,7	$\pm 0,1$
2 000	0,8	$\pm 0,1$
4 000	0,9	$\pm 0,1$

The artificial surface shall be placed on a hard, reflecting surface at the centre of the test environment and shall have a size of at least 3,6 m \times 3,6 m. The construction of the supporting structure shall be such that the requirements for acoustic properties are met with the absorptive material in place. The structure shall support the test set-up such that compression of the absorbing material is avoided.

6.3 Requirements for natural ground surface

The ground at the centre of the test site shall be flat and have good sound-absorbing properties. The surface shall be either forest ground or grass, with the grass or other organic material having a height of (50 ± 20) mm.

7 Testing and operating conditions

Measurements shall be carried out on a new, normal production machine fitted with standard equipment in accordance with the instruction handbook.

The engine and the machine shall be run-in prior to the test in accordance with the manufacturer's instructions. The engine shall be at normal stable operating temperature before the test is started.

The carburettor shall be set to give the specific machine conditions required by the corresponding annex of this standard.

The cutting devices shall be lubricated in accordance with the instruction handbook. No alterations to the initial settings are permitted once measurements have commenced.

An engine speed indicator shall be used to check the speed of the engine. It shall have a measurement uncertainty of $\pm 1,0\%$ of the reading. The indicator and its engagement with the machine shall not affect the operation during testing.

NOTE 1 The specific conditions for a particular machine are given in the corresponding annexes.

Noise emission quantities shall be determined under the specific conditions for the particular type of machine specified in the corresponding annex. The following additionally applies.

- a) Perform a minimum of four measurements with a short break and significant change of speed between each measurement. Separate each measurement at, for example, idle, by a short period of racing, and vice versa. After this speed variation, stable speed conditions shall be obtained before testing is continued.

At least four separate periods of noise data shall be obtained, totalling at least 20 s.

Each signal duration used shall be at least 2 s over which the engine speed is within $\pm 3,5$ r/s.

NOTE 2 The collection of data for the different operating modes need not be carried out in any fixed sequence.

- b) The range of all values noted for each operating mode shall not be greater than 2 dB. If this range is exceeded, repeat the tests until four consecutive results fall within a range of 2 dB. The final value to be retained for each microphone position is the arithmetical mean of these four successive values satisfying this requirement.

For all the conditions specified in the annexes, carry out this procedure when measuring the A-weighted emission sound pressure levels. When determining the A-weighted sound power level, this procedure shall be applied to the sound pressure levels averaged over the six microphone positions.

8 Information to be reported

The following information, as applicable, shall be recorded and reported for all measurements:

- a) machine under test:
 - 1) description of the machine (including its engine displacement, manufacturer, type and serial number, and cutting attachment);
 - 2) operating conditions, as listed in Tables 3 and 4, during acoustical evaluation;
 - 3) dimensions of the log (when applicable);
- b) acoustic environment (description of test environment):
 - 1) if outdoors, a sketch showing the location of the machine with respect to the surrounding terrain, including a physical description of the test environment including a description of the nature of the ground plane;
 - 2) if indoors, a description of the physical treatment of walls, ceiling and floor, including a sketch showing the location of the machine and room contents;
 - 3) value of K_{2A} ;

- c) instrumentation:
- 1) equipment used for the measurements, including name, type, serial number and manufacturer;
 - 2) method used to calibrate the instrumentation system;
 - 3) date and place of the most recent calibration of the acoustical calibrator;
- d) acoustical and other data:
- 1) A-weighted sound pressure levels of the background noise at the microphone positions;
 - 2) measured values and mean values in accordance with Tables 3, 4 and 5;
 - 3) remarks, if any;
 - 4) air temperature and wind speed;
 - 5) date and place of the measurements.

**Table 3 — A-weighted emission sound pressure level determination —
Reporting measured values, mean values and emission values**

Operating condition	Engine speed	Measured A-weighted sound pressure levels					Arithmetic mean value $\overline{L'_{pAX}}$	Correction factor K_{1A}	A-weighted emission sound pressure levels L_{pAX}
		Test no.							
	r/s	1	2	3	4	<i>n</i>	dB	dB	dB
Idling (Id)									
Full load (Fl) ^a									
Racing (Ra) ^a									
<p>The emission sound pressure level for the respective operating condition <i>X</i> is calculated from</p> $L_{pAX} = \overline{L'_{pAX}} - K_{1A}$ <p>where K_{1A} is the background noise correction according to ISO 11201.</p>									
<p>^a According to the test procedure for the machine type (see corresponding annex).</p>									

**Table 4 — A-weighted sound power level determination —
Reporting measured A-weighted sound pressure levels**

Test	Operating condition	Engine speed	L'_{pA1}	L'_{pA2}	L'_{pA3}	L'_{pA4}	L'_{pA5}	L'_{pA6}	$\overline{L'_{pA}}$
		r/s	dB	dB	dB	dB	dB	dB	dB
1	Full load (FI) ^a								
	Racing (Ra) ^a								
2	Full load (FI) ^a								
	Racing (Ra) ^a								
3	Full load (FI) ^a								
	Racing (Ra) ^a								
4	Full load (FI) ^a								
	Racing (Ra) ^a								
<i>n</i>	Full load (FI) ^a								
	Racing (Ra) ^a								
Average sound pressure level $\overline{L'_{pAX}}$	Full load (FI)	$\overline{L'_{pAFI}} = \quad \text{dB}$							
	Racing (Ra)	$\overline{L'_{pARa}} = \quad \text{dB}$							
<p>L'_{pA1} to L'_{pA6} are the measured time-averaged sound pressure levels at the corresponding microphone positions. $\overline{L'_{pA}}$ is the average of sound pressure levels L'_{pA1} to L'_{pA6} according to ISO 3744:2010, Equation (12). $\overline{L'_{pAX}}$ is the arithmetic average of the values for $\overline{L'_{pA}}$ from each test for the respective operating condition (FI and Ra). Individual values for L'_{pA} shall only be reported if available. The test procedure may include automatic averaging.</p>									
<p>^a According to the test procedure for the machine type (see corresponding annex).</p>									

Table 5 — A-weighted sound power level determination — Table for reporting sound power data

Operating condition	Average sound pressure level $\overline{L'_{pAX}}$ dB	Correction factor K_{1A} dB	Surface sound pressure level $\overline{L_{pAfX}}$ dB	Surface level L_S dB	Sound power level L_{WAx} dB
Full load (Fl) ^a	$\overline{L'_{pAFI}} =$				
Racing (Ra) ^a	$\overline{L'_{pARa}} =$				
Environmental correction $K_{2A} =$ dB					
<p>$\overline{L'_{pAX}}$ is the arithmetic average of the values for $\overline{L'_{pA}}$ from each test for the respective operating condition (Fl and Ra).</p> <p>The surface sound pressure level, $\overline{L_{pAfX}}$, for the respective operating condition X is calculated from:</p> $\overline{L_{pAfX}} = \overline{L'_{pAX}} - K_{1A} - K_{2A}$ <p>where</p> <p>$\overline{L'_{pAX}}$ is replaced by $\overline{L'_{pAFI}}$ or $\overline{L'_{pARa}}$ respectively;</p> <p>K_{1A} is the background noise correction according to ISO 3744:2010, 8.2.3;</p> <p>K_{2A} is the environmental correction [see Clause 5, f)].</p> <p>The sound power level, L_{WAx}, for the respective operating condition X is calculated from:</p> $L_{WAx} = \overline{L_{pAfX}} + L_S$ <p>where</p> $L_S = 10 \lg \frac{S}{S_0},$ expressed in dB, with $S_0 = 1 \text{ m}^2$ and where S is the surface of the hemisphere in square metres.					
^a According to the test procedure for the machine type (see corresponding annex).					

9 Declaration and verification of noise emission values

Noise declaration is the responsibility of the manufacturer. If undertaken, verification of the declared values shall be carried out according to methods given in ISO 4871:1996, Annex A. Calculated equivalent A-weighted emission sound pressure levels for the work cycles shall be declared, by a dual-number declaration (see ISO 4871:1996, Annex B). Calculated equivalent A-weighted sound power levels for the work cycles shall be declared, by a single-number declaration (see ISO 4871:1996, Annex B).

NOTE 1 See also Annex H concerning sound power level declaration.

Noise emission values (A-weighted sound power level and A-weighted emission sound pressure level at the operator's position) for applicable operating modes (idling, full load, racing) shall be made available on request.

The noise declaration shall include a reference to this noise test code and to the basic standard used (ISO 3744 and/or ISO 11201). Deviations, if any, from this test code and/or the basic standards shall also be indicated.

The uncertainty, K , to be associated with the declared noise level(s) is based on the total standard deviation, σ_t , which is composed of the standard deviation of reproducibility, σ_R , and the standard deviation of production, σ_p . Guidelines for σ_R are given in the annexes. The determination of σ_p shall be carried out by the manufacturer, based on its experience of the production variation.

NOTE 2 See Annex G for a summary of the results of round robin tests for some machines that took place in 2007/2008.

Information on noise emission should also be provided in the sales literature.

Annex A (normative)

Specific conditions for chain saws

A.1 Chain-saw conditions and test timber

Measurements shall be carried out on a chain-saw with standard guide bar and saw-chain and where the guide bar length is such that the dimensions in Figure A.1 are met.

A test timber in the form of a rectangular log shall be placed on a sawhorse so that its centreline is (600 ± 10) mm above the ground (see Figure A.1).

The lateral width of the test timber in the direction of the guide bar shall be (200 ± 10) mm and the vertical height (400 ± 50) mm. The test timber shall have a slot with a width of (40 ± 2) mm and a depth of (260 ± 10) mm.

A.2 Mounting and orientation of chain-saw

A.2.1 General

The chain-saw shall be mounted on a test stand with the bar centreline horizontal, as indicated in Figure A.1.

The chain-saw and the bar with the saw chain shall not touch the log during the measurements. The saw chain shall be kept (15 ± 5) mm from the bottom of the slot. There shall be a distance of (10 ± 5) mm between the tip of the spiked bumper and the rear surface of the log.

The bar shall be provided with a water brake (or equivalent) at the tip of the bar, capable of absorbing the energy of the saw. If a water brake is used, the speed of the engine shall be controlled by the water flow inside the water brake. The weight, shape or design of the loading device shall be such that there is no influence on the noise readings. See Annex F for an example of a water brake.

A.2.2 A-weighted sound power level measurement

During the measurements, the tip of the bar shall be directed above, and in the direction of, the positive x -axis and with the front handle vertically above the centre point of the hemisphere.

The saw shall be mounted in the test fixture as described by Figure A.1. A fixture which holds the saw in the intended position and which does not cause reflections shall be used. A flexible mount is recommended for avoiding any structural resonance.

A.2.3 A-weighted emission sound pressure level measurement

During the measurement, the microphone shall be located (700 ± 10) mm above the top of the front handle and vertically above the centreline between the root of the spiked bumper and the outer edge of the rear handle. The microphone shall be in the plane of the rear handle (see Figure A.1).

Dimensions in millimetres

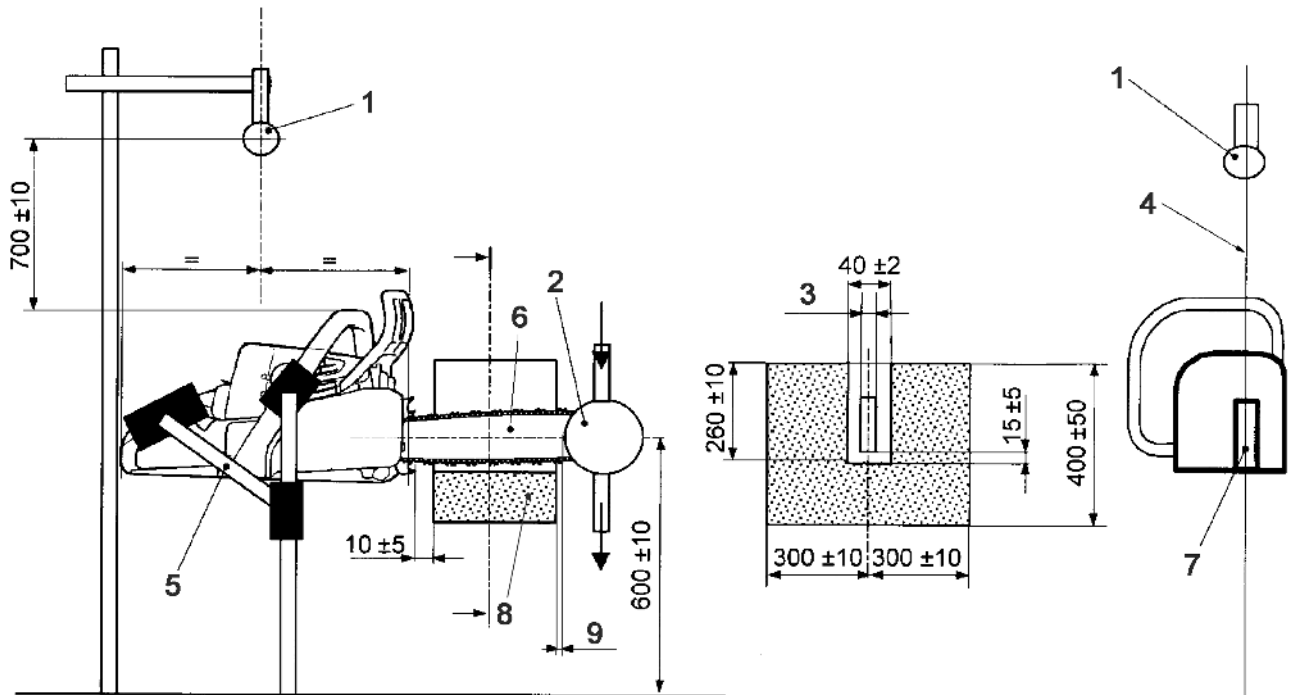

Key

- 1 position of microphone (for operator's position)
- 2 loading device (see example in Annex F)
- 3 width of guide bar
- 4 centre plane through guide bar
- 5 test fixture
- 6 centreline of guide bar positioned horizontally
- 7 rear handle
- 8 test timber (wood block, simulating a log)
- 9 distance between test timber and loading device of ≥ 10 mm to < 150 mm

Figure A.1 — Test set-up for chain-saws

A.3 Test procedure

A.3.1 General

The tests shall be carried out in the following operating modes:

- a) for machines with an engine displacement of < 80 cm³: at idling, full load and racing;
- b) for machines with an engine displacement of ≥ 80 cm³: at idling and full load.

A.3.2 Idling

Take the measurements with fully released throttle trigger. The idling speed shall be adjusted in accordance with the machine manufacturer's instructions. The saw chain shall not move. In this test mode, the chain-saw shall be operated without the log and the loading device.

A.3.3 Full load

Take the measurements during a simulated crosscutting with the throttle fully open. The guide bar with the loading device shall be placed in the slot of the log as shown in Figure A.1. The engine speed shall be kept at the maximum engine power speed, determined in accordance with ISO 7293, by adjustment of the load applied by the loading device.

A.3.4 Racing

Take the measurements at an engine speed of 133 % of the speed at maximum engine power, determined in accordance with ISO 7293.

If the engine has a speed limiter set below that speed, measure at the maximum speed achievable. If the engine does not run with a stable speed, carry out the test at the maximum possible stable speed. This speed shall, however, not be more than 8 r/s below the maximum speed as determined by the speed governor. The engine speed shall be controlled with the throttle trigger. In this test mode, the chain-saw shall be operated without the log and the loading device.

A.4 Determination of sound levels for work cycles

A.4.1 Chain-saws with engine displacement < 80 cm³

The equivalent A-weighted emission sound pressure level, L_{pAeq} , shall be determined as follows:

$$L_{pAeq} = 10 \lg \frac{1}{3} \left(10^{0,1L_{pAId}} + 10^{0,1L_{pAFI}} + 10^{0,1L_{pARa}} \right) \text{ dB}$$

where

L_{pAId} is the emission sound pressure level for the idling operating condition;

L_{pAFI} is the emission sound pressure level for the full-load operating condition;

L_{pARa} is the emission sound pressure level for the racing operating condition.

The A-weighted sound power level, $L_{WAfI+Ra}$, shall be determined as follows:

$$L_{WAfI+Ra} = 10 \lg \frac{1}{2} \left(10^{0,1L_{WAfI}} + 10^{0,1L_{WARa}} \right) \text{ dB}$$

where

L_{WAfI} is the sound power level for the full-load operating condition;

L_{WARa} is the sound power level for the racing operating condition.

A.4.2 Chain-saws with engine displacement $\geq 80 \text{ cm}^3$

The equivalent A-weighted emission sound pressure level, L_{pAeq} , shall be determined as follows:

$$L_{pAeq} = 10 \lg \frac{1}{2} \left(10^{0,1L_{pAId}} + 10^{0,1L_{pAFI}} \right) \text{ dB}$$

where

L_{pAId} is the emission sound pressure level for the idling operating condition;

L_{pAFI} is the emission sound pressure level for the full-load operating condition.

The A-weighted sound power level shall be determined as the sound power level for full load condition, L_{WAFl} .

Annex B (normative)

Specific conditions for brush cutters and grass-trimmers

B.1 Machine conditions

Measurements shall be carried out on a machine with all standard attachments that can cause different sound emissions.

If the cutting means is of a string type, the string length shall be adjusted to its maximum length minus 5 mm.

For standard attachments, see the instruction handbook or machine manufacturer's instruction.

B.2 Mounting and orientation of machine

B.2.1 Mounting of machine on test fixture

Use a fixture that holds the machine in the intended position and does not cause reflections. A flexible mount should be used to avoid any structural resonance.

The centre of the cutting attachment shall be such that H is (300 ± 25) mm above the ground for brush-cutters and (50 ± 25) mm above the ground for grass-trimmers (see Figures B.1 to B.3).

a) Machine with suspension point

Attach the machine to the test fixture so that the suspension point is (775 ± 10) mm above the ground. If the suspension point is adjustable, select the position so that dimension H is within the required range. See Figure B.1.

b) Machine without suspension point

Attach the machine to the test fixture so that the middle of the grip position of the rear handle is (775 ± 10) mm above the ground. See Figure B.2.

c) Machine with backpack power unit

Attach the shaft assembly to the test fixture according to b), above, with the backpack power unit attached to a test fixture for the shoulder harness so that the lower edge of the back padding is $(1\ 030 \pm 25)$ mm above the ground. The backpack unit shall be located such that the rear handle is (300 ± 25) mm to the right of that vertical centreline of the backpack unit and (200 ± 25) mm in front of the vertical centreline through the fixture for the shoulder harness. See Figure B.3.

B.2.2 Orientation of machine for A-weighted sound power level measurement

The machine shall be oriented so that the shaft is over the x -axis and the centre of the right/rear handle is on the y -axis.

B.2.3 Position of microphone for A-weighted sound pressure level measurement

The position of the microphone shall be as follows.

- For machines with a suspension point, the microphone shall be located (875 ± 10) mm vertically above the suspension point. See Figure B.1.
- For machines without a suspension point, the microphone shall be located (875 ± 10) mm vertically above the centre of the right/rear handle. See Figure B.2.
- For machines with a backpack power unit, the microphone shall be located (875 ± 10) mm above the centre of the right/rear handle and vertically above the fixture of the shoulder harness. See Figure B.3.

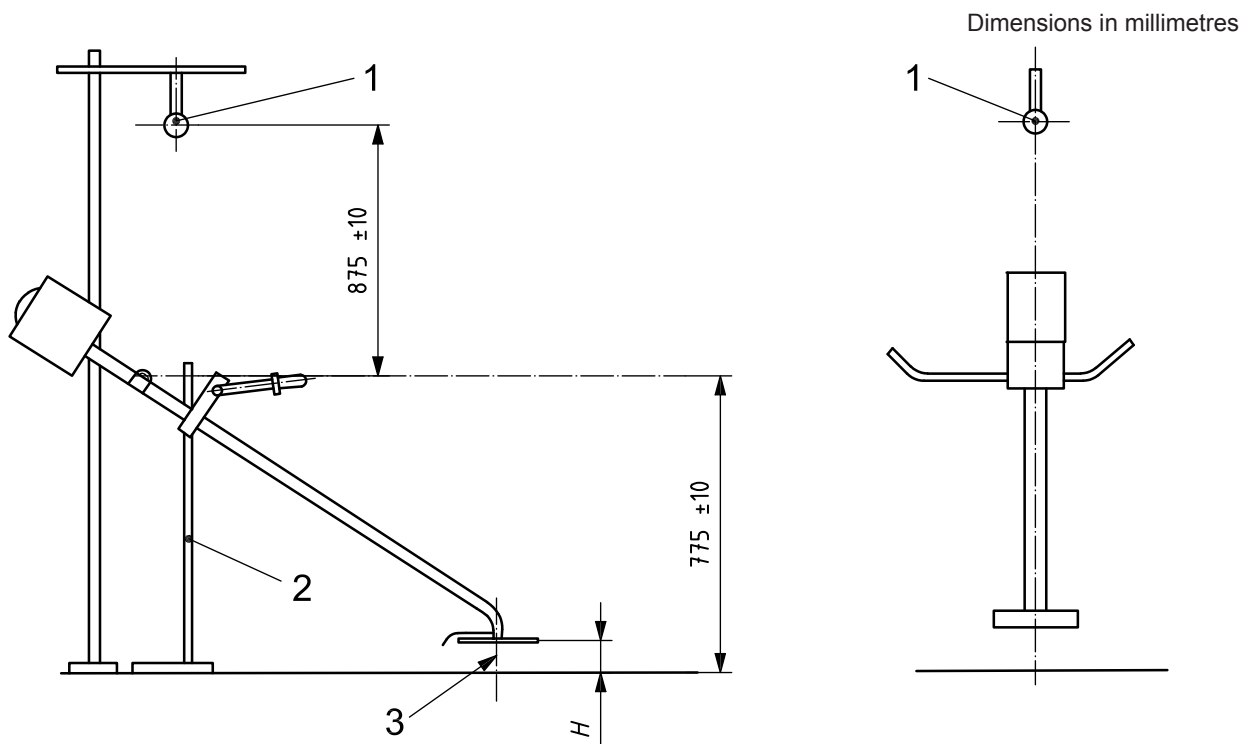

Key

- 1 lateral position of microphone (for operator's position)
- 2 test fixture
- 3 axle of cutting tool

Figure B.1 — Test set-up for grass-trimmers and brush-cutters with integrated power source and suspension point

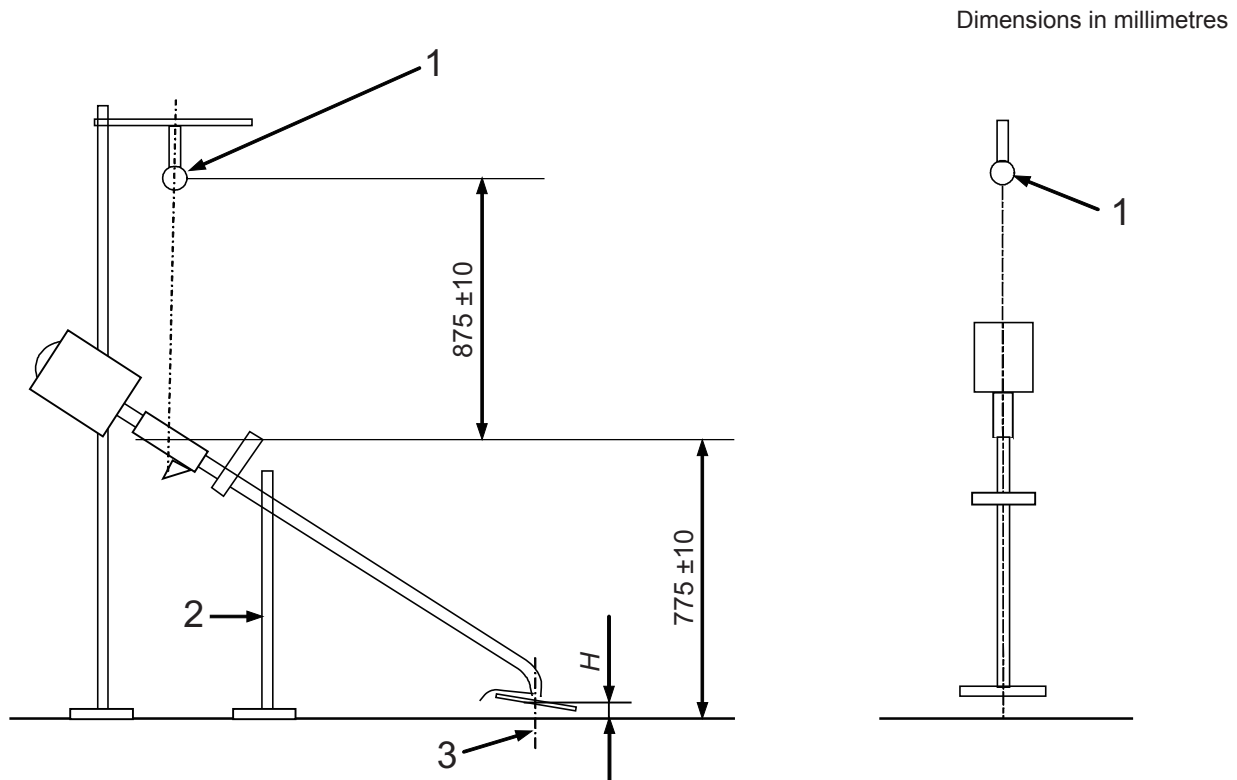
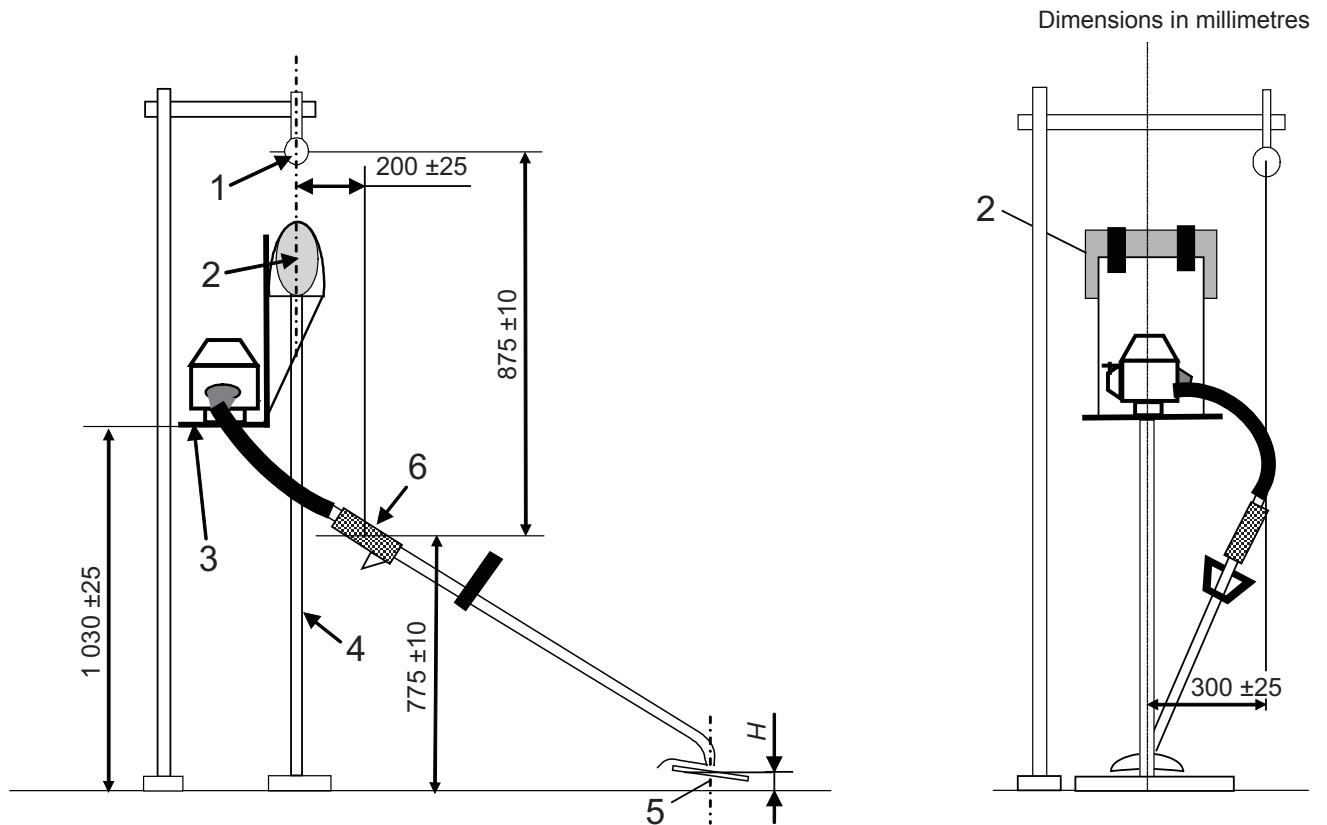

Figure B.2 — Test set-up for grass-trimmers and brush-cutters with integrated power source but without suspension point



Key

- | | |
|--|------------------------|
| 1 lateral position of microphone (for operator's position) | 4 test fixture |
| 2 fixture for shoulder harness | 5 axle of cutting tool |
| 3 lower edge of back-padding | 6 rear handle |

Figure B.3 — Test set-up for backpack powered grass-trimmers and brush-cutters

B.3 Test procedure

B.3.1 General

Noise emission quantities shall be determined for two different operating conditions: idling and racing.

B.3.2 Idling

Take the measurements with the throttle trigger fully released. The idling speed shall be adjusted in accordance with the machine manufacturer's instructions. The cutting attachment shall not move.

B.3.3 Racing

For brush-cutters, take the measurements at an engine speed of 133 % of the speed at maximum engine power, determined in accordance with ISO 8893.

For grass-trimmers, take the measurements with the flexible line adjusted to the full usable length, in accordance with B.1, and with the throttle fully open. If the maximum speed exceeds 133 % of the speed at maximum engine power, control the speed with the throttle trigger so that it is maintained at 133 %.

If the engine has a speed limiter set below that speed, measure at the maximum speed achievable. If the engine does not run with a stable speed, carry out the test at the maximum possible stable speed. This speed shall, however, not be more than 8 r/s below the maximum speed as determined by the speed governor. The engine speed shall be controlled with the throttle trigger.

B.4 Determination of sound levels for work cycles

The equivalent A-weighted emission sound pressure level, L_{pAeq} , shall be determined as follows:

$$L_{pAeq} = 10 \lg \frac{1}{2} \left(10^{0,1L_{pAld}} + 10^{0,1L_{pARa}} \right) \text{dB}$$

where

L_{pAld} is the emission sound pressure level for the idling operating condition;

L_{pARa} is the emission sound pressure level for the racing operating condition.

The A-weighted sound power level shall be determined as the sound power level for the racing operating condition, L_{wARa} .

Annex C (normative)

Specific conditions for pole-mounted powered pruners

C.1 Machine conditions

Measurements shall be carried out on a machine with the pole adjusted to its shortest position and with all standard attachments that can cause different sound emissions.

For standard attachments, see the instruction handbook or machine manufacturer's instructions.

C.2 Mounting and orientation of machine

C.2.1 Mounting of machine on test fixture

Attach the machine to the test fixture so that the machine is positioned in accordance with Figures C.1 and C.2.

Use a fixture that holds the machine in the intended position and does not cause reflections. A flexible mount should be used to avoid any structural resonance.

a) Machine with integrated power unit

Attach the machine to the test fixture so that the suspension point is (775 ± 10) mm above the ground and hold inclined at $60^\circ \pm 10^\circ$ in accordance with Figure C.1.

b) Machine with backpack power unit

Attach the shaft assembly to the test fixture according to a), above, with the backpack power unit attached to a test fixture for the shoulder harness so that the lower edge of the back padding is $(1\ 030 \pm 25)$ mm above the ground. The backpack unit shall be located such that the rear handle is (300 ± 25) mm to the right of that vertical centreline of the backpack unit and (200 ± 25) mm in front of the vertical centreline through the fixture for the shoulder harness. See Figure C.2.

C.2.2 Orientation of machine for A-weighted sound power level measurement

The machine shall be oriented so that the shaft is over the x -axis and the centre of the right/rear handle is on the y -axis.

C.2.3 Position of microphone for A-weighted sound pressure level measurement

The position of the microphone shall be as follows.

- For machines with an integrated power unit the microphone shall be located (875 ± 10) mm vertically above the suspension point. See Figure C.1.
- For machines with a backpack power unit the microphone shall be located $(1\ 650 \pm 10)$ mm above the ground, in a position vertically above the fixture for the shoulder harness and at a distance of (300 ± 10) mm to the right of the centreline of the backpack power unit. See Figure C.2.

Dimensions in millimetres

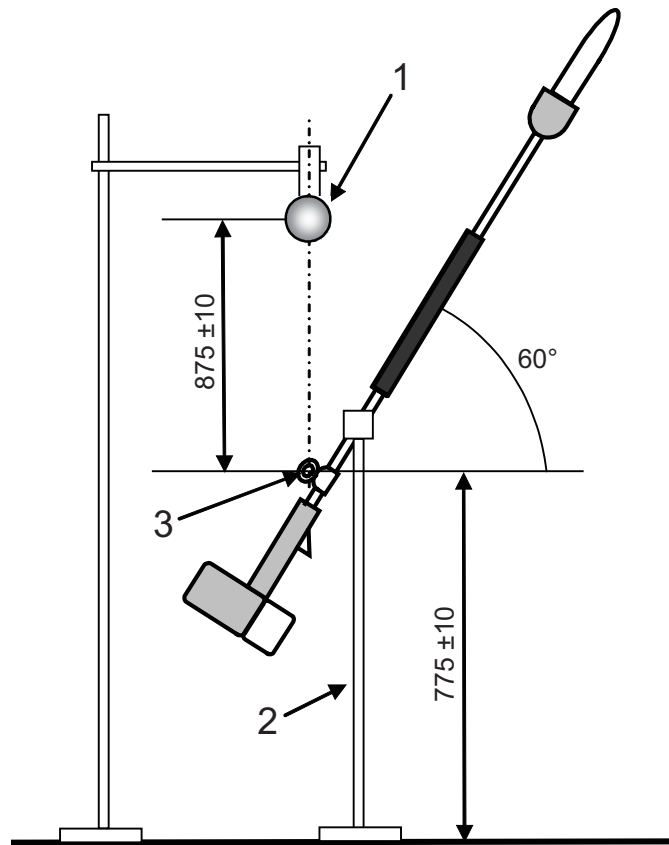

Key

- 1 lateral position of microphone (for operator's position)
- 2 test fixture
- 3 suspension point

Figure C.1 — Test set-up for pole-mounted powered pruner with integrated power source

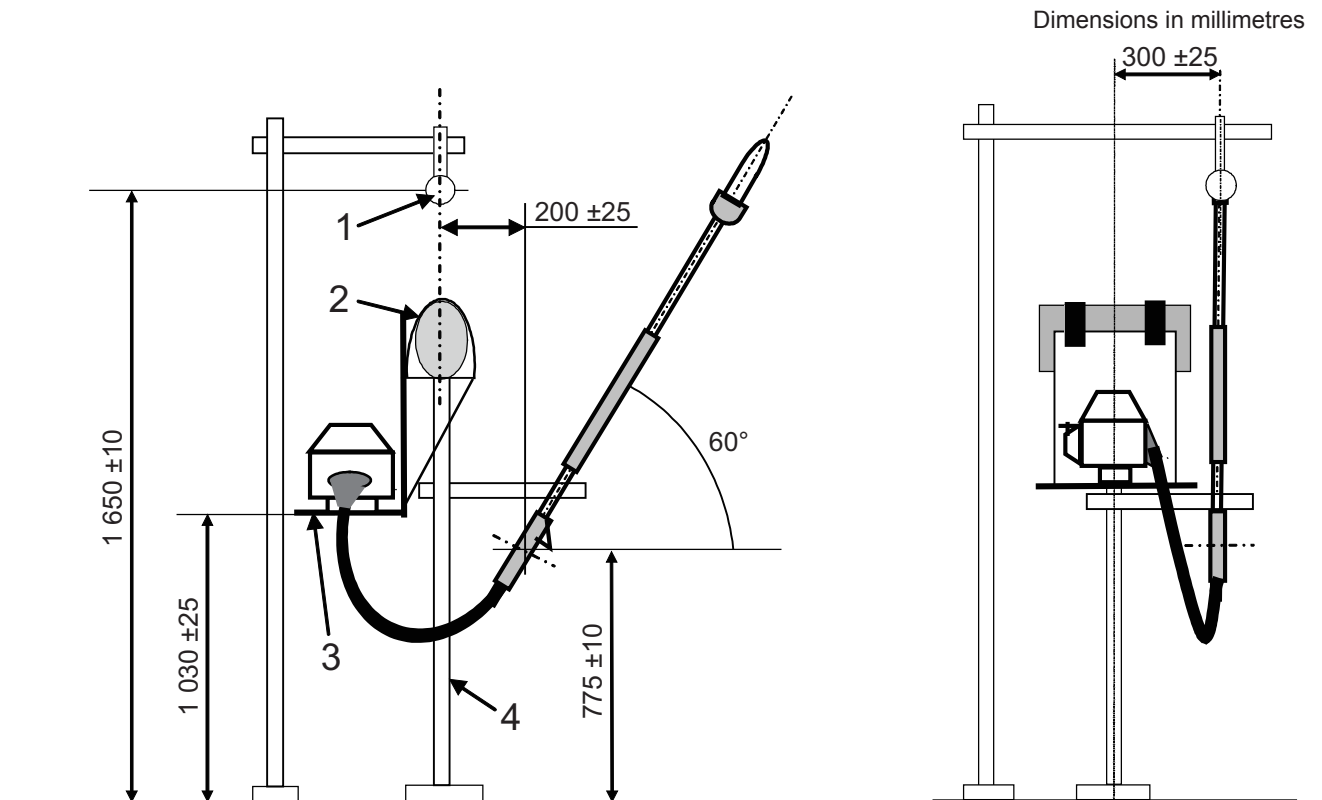

Key

- 1 lateral position of microphone (for operator's position)
- 2 fixture for shoulder harness
- 3 lower edge of back-padding
- 4 test fixture

Figure C.2 — Test set-up for pole-mounted powered pruner with backpack power source

C.3 Test procedure

C.3.1 General

Noise emission quantities shall be determined for two different operating conditions: idling and racing.

C.3.2 Idling

Take the measurements with the throttle trigger fully released. The idling speed shall be adjusted in accordance with the machine manufacturer's instructions. The cutting attachment shall not move

C.3.3 Racing

Take the measurements at an engine speed of 133 % of the speed at maximum engine power, determined in accordance with ISO 8893.

If the engine has a speed limiter set below that speed, measure at the maximum speed achievable. If the engine does not run with a stable speed, carry out the test at the maximum possible stable speed. This speed shall, however, not be more than 8 r/s below the maximum speed as determined by the speed governor. The engine speed shall be controlled with the throttle trigger.

C.4 Determination of sound levels for work cycles

The equivalent A-weighted emission sound pressure level, L_{pAeq} , shall be determined as follows:

$$L_{pAeq} = 10 \lg \frac{1}{2} \left(10^{0,1L_{pAld}} + 10^{0,1L_{pARa}} \right) \text{dB}$$

where

L_{pAld} is the emission sound pressure level for the idling operating condition;

L_{pARa} is the emission sound pressure level for the racing operating condition.

The A-weighted sound power level shall be determined as the sound power level for racing operating condition, L_{WARa} .

Annex D (normative)

Specific conditions for hedge-trimmers

D.1 Machine conditions

Measurements shall be carried out on a machine with standard equipment, adjusted, if applicable, to its shortest length and so that the cutting attachment is in the position closest to the operator.

For standard attachments and adjustments see the instruction handbook or machine manufacturer's instructions.

D.2 Mounting and orientation of machine

D.2.1 Mounting of machine on test fixture

Attach the machine to the test fixture so that the middle of the grip position of the front or, for long-shafted hedge-trimmers, rear handle is (775 ± 10) mm above the ground and with the cutting attachment positioned in accordance with Figures D.1 and D.2.

Long-shafted hedge-trimmers shall be held at an angle of $45^\circ \pm 10^\circ$ and with the cutting attachment as far as possible in line with the shaft tube, as shown in Figure D.2. Other machines shall be held with the cutting attachment horizontal.

Use a fixture that holds the machine in the intended position and does not cause reflections. A flexible mount should be used to avoid any structural resonance.

D.2.2 Orientation of machine for A-weighted sound power level measurement

Attach the machine to the test fixture so that the cutting attachment is over the x -axis and the centre of the front handle, or for long reach hedge-trimmers the rear handle, is on the y -axis.

D.2.3 Position of microphone for A-weighted sound pressure level measurement

The position of the microphone shall be as follows.

- For hedge-trimmers other than long-shafted models, the microphone shall be located (700 ± 10) mm above the top of the front handle and vertically above the centreline between the outer edge of the front and the rear handle. See Figure D.1.
- For long-shafted hedge-trimmers, the microphone shall be located (875 ± 10) mm vertically above the centre of the right/rear handle. See Figure D.2

Dimensions in millimetres

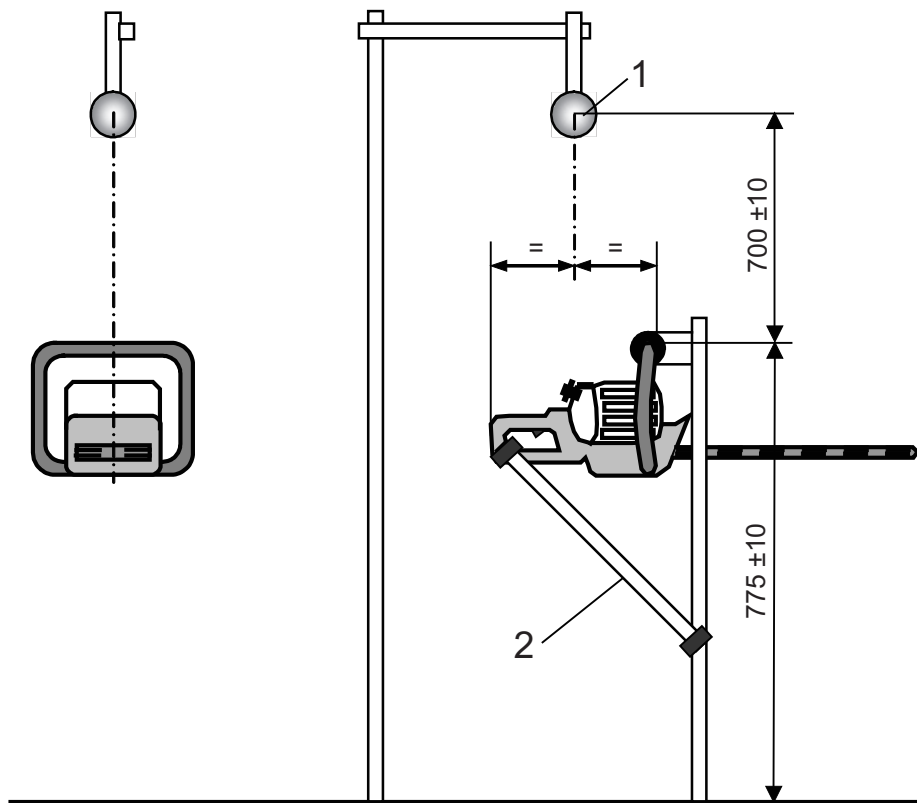

Key

- 1 lateral position of microphone (for operator's position)
- 2 test fixture

Figure D.1 — Test set-up for hedgetrimmer

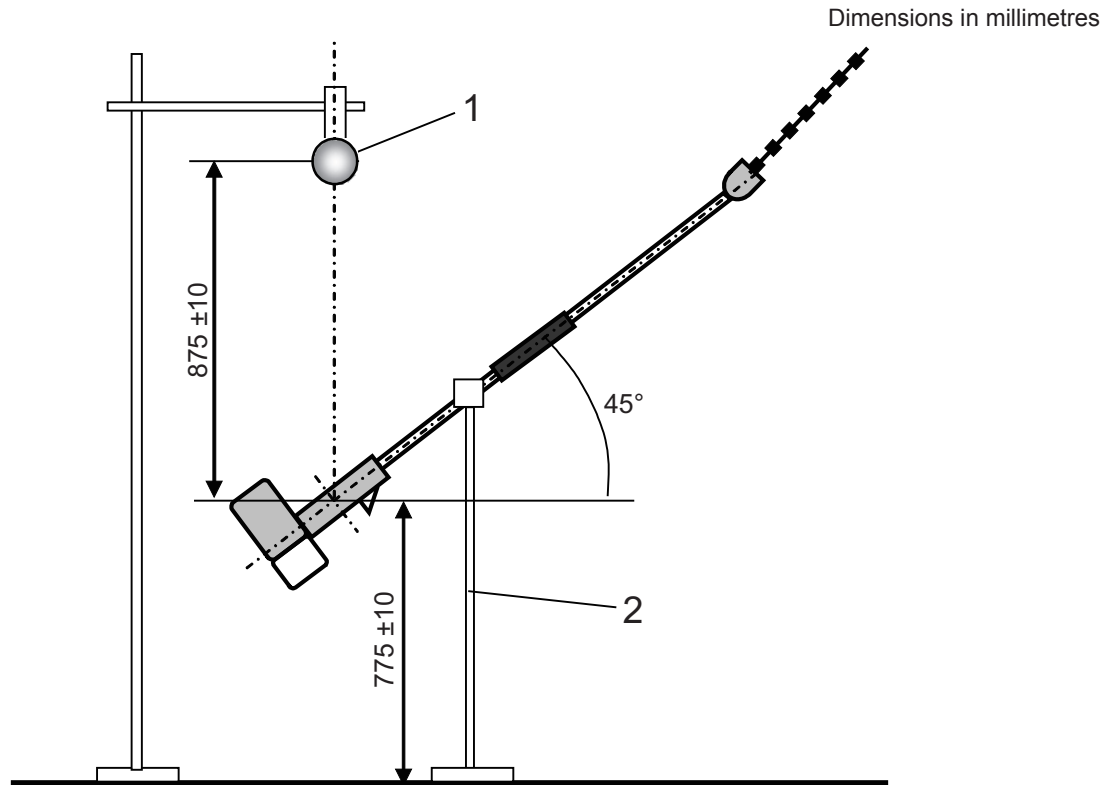

Figure D.2 — Test set-up for long-shafted hedge-trimmer

D.3 Test procedure

D.3.1 General

Noise emission quantities shall be determined for two different operating conditions: idling and racing.

D.3.2 Idling

Take the measurements with the throttle trigger fully released. The idling speed shall be adjusted in accordance with the machine manufacturer's instructions. The cutting attachment shall not move.

D.3.3 Racing

Take the measurements at an engine speed of 133 % of the speed at maximum engine power, determined in accordance with ISO 7293.

If the engine has a speed limiter set below that speed, measure at the maximum speed achievable. If the engine does not run with a stable speed, carry out the test at the maximum possible stable speed. This speed shall, however, not be more than 8 r/s below the maximum speed as determined by the speed governor. The engine speed shall be controlled with the throttle trigger.

D.4 Determination of sound levels for work cycles

The equivalent A-weighted emission sound pressure level, L_{pAeq} , shall be determined as follows:

$$L_{pAeq} = 10 \lg \left(\frac{1}{5} 10^{0,1L_{pAld}} + \frac{4}{5} 10^{0,1L_{pARa}} \right) \text{dB}$$

where

L_{pAld} is the emission sound pressure level for the idling operating condition;

L_{pARa} is the emission sound pressure level for the racing operating condition.

The A-weighted sound power level shall be determined as the sound power level for the racing operating condition, L_{WARa} .

Annex E (normative)

Specific conditions for garden blower/vacuum

E.1 Machine conditions

Measurements shall be carried out on a machine with standard equipment.

For standard equipment, see the instruction handbook or machine manufacturer's instructions.

E.2 Mounting and orientation of machine

E.2.1 Mounting of machine on test fixture

Attach the machine to the test fixture so that the machine is positioned in accordance with Figures E.1 to E.3.

Use a fixture that holds the machine in the intended position and does not cause reflections. A flexible mount should be used to avoid any structural resonance.

a) Machine with suspension point

Attach the machine to the test fixture so that the suspension point is (775 ± 10) mm above the ground. The lowest point of the air nozzle shall be (50 ± 10) mm above the ground. See Figure E.1. If the suspension point is adjustable, select the position so that the lowest point of the air nozzle is within the required range.

b) Machine without suspension point

Attach the machine to the test fixture so that the middle of the grip position of handle to which the throttle trigger is fitted is (775 ± 10) mm above the ground. The lowest point of the air nozzle shall be (50 ± 10) mm above the ground. See Figure E.2.

c) Machine with backpack power unit

Attach the blower tube assembly to the test fixture according to b), above, with the backpack power unit attached to a test fixture for the shoulder harness so that the lower edge of the back padding is $(1\ 030 \pm 10)$ mm above the ground. The air nozzle shall point forward, perpendicular to the backpack for the power unit, (300 ± 25) mm to the right of the vertical centreline of the backpack unit. The lowest point of the air nozzle shall be (50 ± 10) mm above the ground. The handle shall be fixed (200 ± 25) mm in front of the vertical centreline through the microphone. See Figure E.3.

E.2.2 Orientation of machine for A-weighted sound power level measurement

The machine shall be oriented so that the nozzle is parallel to the x -axis and the centre of the right/rear handle is on the y -axis.

E.2.3 Position of microphone for A-weighted sound pressure level measurement

The position of the microphone shall be as follows.

- For machines with a suspension point, the microphone shall be located (875 ± 10) mm vertically above the suspension point. See Figure E.1.
- For machines without a suspension point, the microphone shall be located (875 ± 10) mm vertically above the centre of the handle to which the throttle trigger is fitted. See Figure E.2.
- For machines with a backpack power unit, the microphone shall be located $(1\ 650 \pm 10)$ mm above the ground, in a position vertically above the fixture for the shoulder harness and at a distance of (300 ± 10) mm to the right of the centreline of the backpack power unit. See Figure E.3

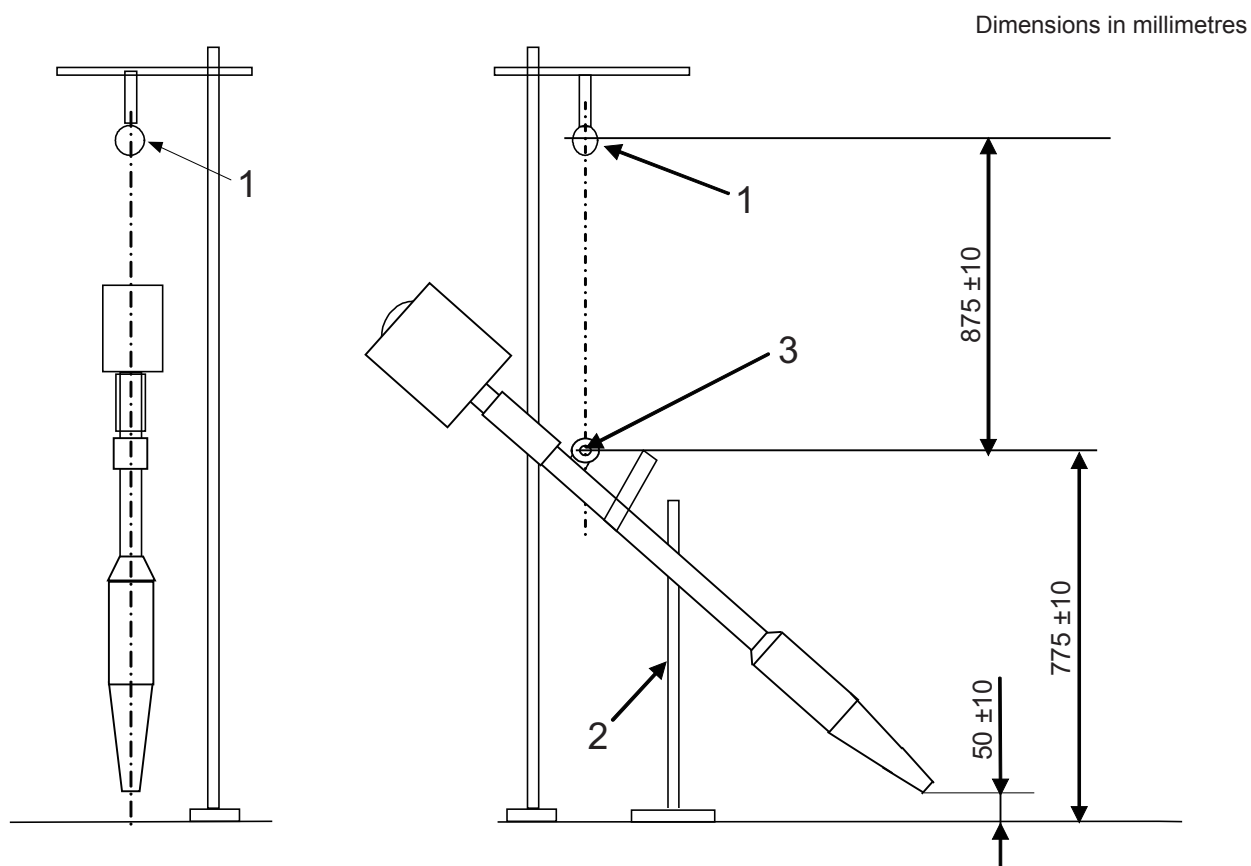

Key

- 1 lateral position of microphone (for operator's position)
- 2 test fixture
- 3 suspension point

Figure E.1 — Test set-up for garden blower/vacuum with integrated power source and with suspension point

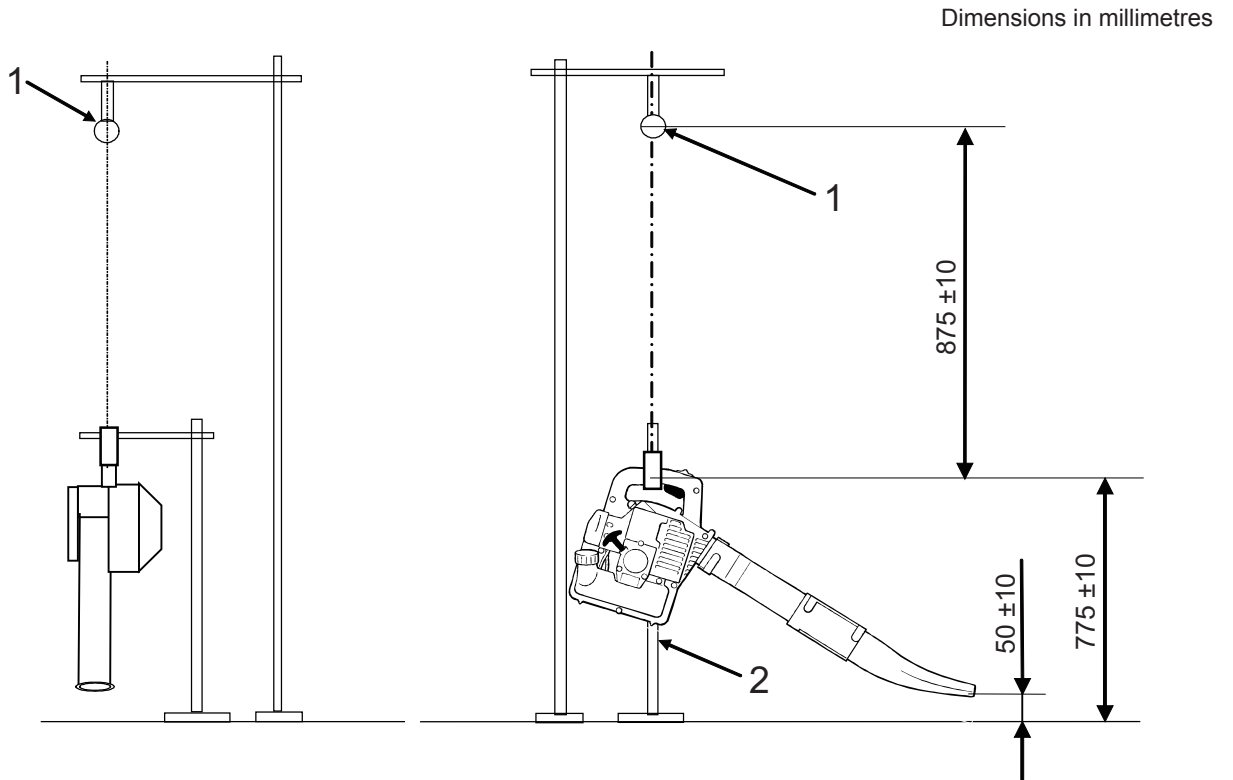

Key

- 1 lateral position of microphone (for operator's position)
- 2 test fixture

**Figure E.2 — Test set-up for garden blower/vacuum
with integrated power source and without suspension point**

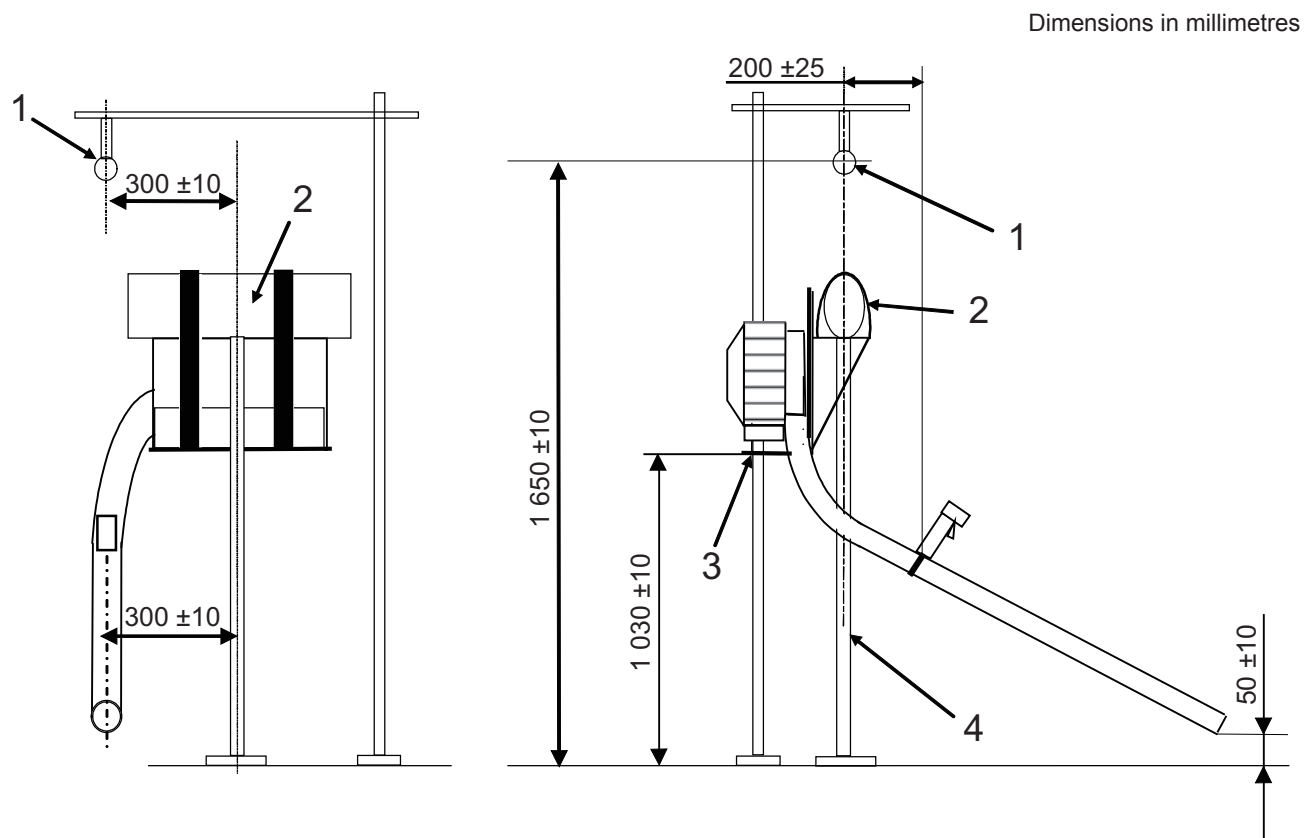

Key

- 1 lateral position of microphone (for operator's position)
- 2 fixture for shoulder harness
- 3 lower edge of back-padding
- 4 test fixture

Figure E.3 — Test set-up for garden blower/vacuum with backpack power source

E.3 Test procedure

E.3.1 General

Noise emission quantities shall be determined for two different operating conditions: idling and full load.

E.3.2 Idling

Take the measurements with fully released throttle trigger. The idling speed shall be adjusted in accordance with the machine manufacturer's instructions.

E.3.3 Full load

Take the measurements at maximum engine speed achieved with the throttle fully open.

E.4 Determination of sound levels for work cycles

The equivalent A-weighted emission sound pressure level (L_{pAeq}) shall be determined as follows:

$$L_{pAeq} = 10 \lg \left(\frac{1}{7} 10^{0,1L_{pAId}} + \frac{6}{7} 10^{0,1L_{pAFI}} \right) \text{ dB}$$

where

L_{pAId} is the emission sound pressure level for the idling operating condition;

L_{pAFI} is the emission sound pressure level for the full load operating condition.

The A-weighted sound power level shall be determined as the sound power level for the full load operating condition (L_{WAFl}).

Annex F
(informative)

Example of water brake mounted on chain saw bar to simulate cutting

See Figure F.1.

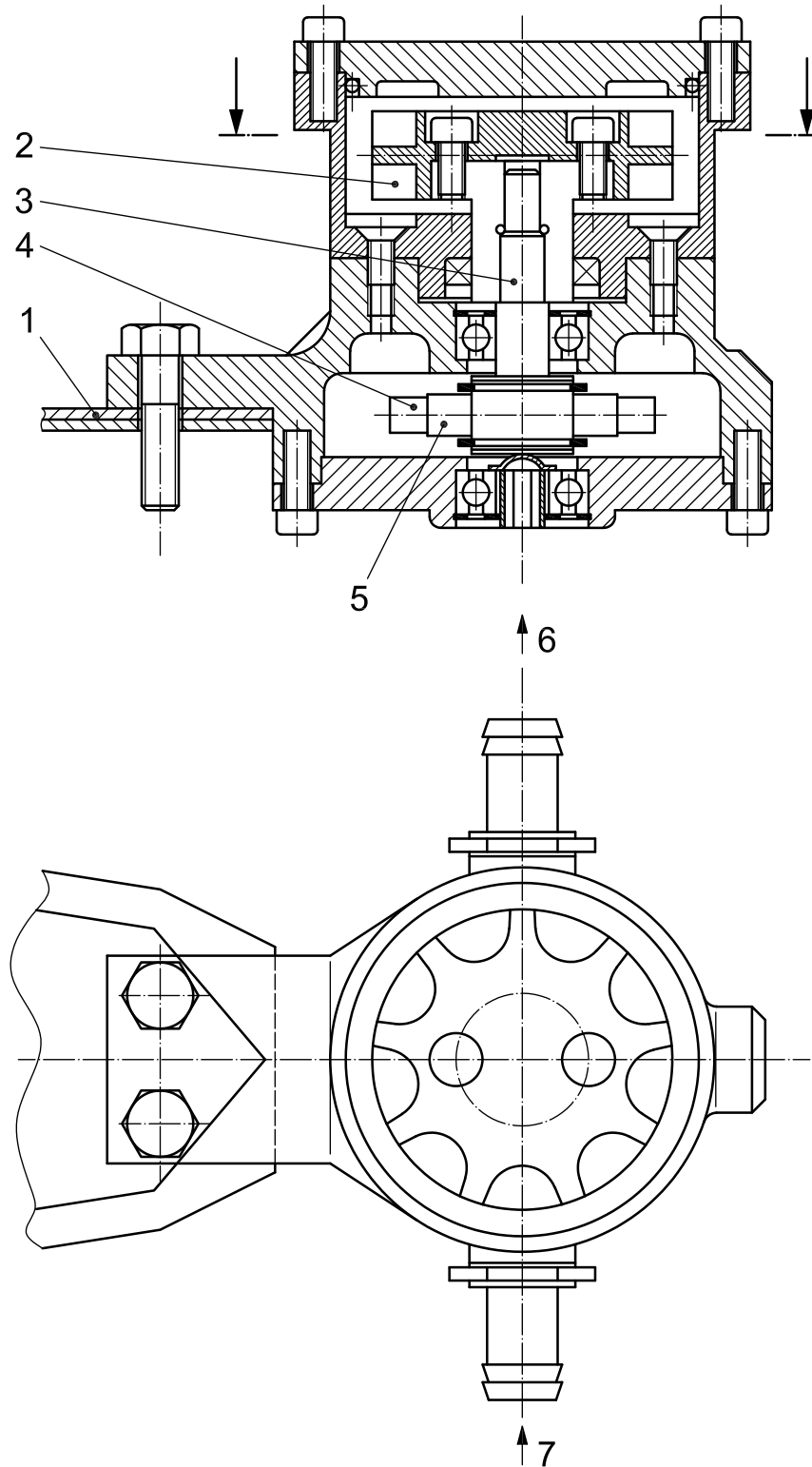

Key

- | | | | |
|---|------------|---|--------------|
| 1 | guide bar | 5 | sprocket |
| 2 | pump wheel | 6 | water outlet |
| 3 | shaft | 7 | water inlet |
| 4 | saw chain | | |

Figure F.1 — Example of water brake mounted on chain-saw bar

Annex G (informative)

Summary of results from round robin tests 2007/2008 on single chain saw, brush saw and grass-trimmer

This annex summarizes (see Tables G.1 and G.2) the results in the form of average values, \bar{x} , and calculated standard deviation, σ_R , from these values. The tests were carried out during 2007 and 2008, with the aim of evaluating the accuracy and repeatability of the measurement and reporting procedure given in ISO 22868:2005.

**Table G.1 — Average values, \bar{x} , and calculated standard deviation, σ_R ,
from A-weighted sound power determination**

Sound power level L_W dB	Chain-saw		Brush-saw		Grass-trimmer	
	\bar{x} dB	σ_R m/s ²	\bar{x} dB	σ_R m/s ²	\bar{x} dB	σ_R m/s ²
Idling	86,1	0,7	87,4	0,7	96,9	1,7
Full Load	112,3	0,7	—	—	—	—
Racing	115,1	0,7	109,5	1,0	108,6	1,3
Equivalent	112,2	0,6	106,5	1,0	105,9	1,3
No. of laboratories	8		7		7	

**Table G.2 — Average values, \bar{x} , and calculated standard deviation, σ_R , from A-weighted
emission sound pressure levels measured at operator position**

Sound pressure level L_p	Chain-saw		Brush-saw		Grass-trimmer	
	\bar{x} dB	σ_R m/s ²	\bar{x} dB	σ_R m/s ²	\bar{x} dB	σ_R m/s ²
Idling	77,2	0,8	76,2	1,0	88,6	0,9
Full Load	103,9	0,6	—	—	—	—
Racing	107,1	1,1	99,4	0,5	100,3	1,0
Equivalent	104	0,9	96,4	0,5	97,5	0,9
No. of laboratories	8		7		7	

Annex H (informative)

A-weighted sound power level declaration according to the EU Directive on noise emission in the environment by equipment for use outdoors, 2000/14/EC

According to European Directive 2000/14/EC, the A-weighted sound power level is to be declared for machines used outdoors, but the determination differs from the test code given in this International Standard in respect of the following.

Microphone positions

Microphones 1 to 4 (see Figure 1) are required by the test code given in this International Standard to be located $0,38r$ above the ground surface; whereas in 2000/14/EC it is 1,5 m. For normal cases, where the radius of the hemisphere is 4 m, there is a minor difference (1,52 m instead of 1,5 m), but for other radii there will be a significant difference, which can influence the measured sound pressure levels at these points.

Microphones 5 and 6 are required by the test code given in this International Standard to be located with x -coordinate $0,28r$; whereas in 2000/14/EC it is $0,27r$. For a hemisphere with a 4 m radius, there is a small difference of 1,12 m and 1,08 m, respectively. This difference could give minor reduced values for measurements taken according to 2000/14/EC compared with those measured according to this test code.

Declaration of sound power levels

In addition to the single-number declaration (= guaranteed value), 2000/14/EC also requires the measured value to be stated in the Declaration of Conformity.

NOTE For further details, see EC Position Paper on Guidelines for the application of the European Parliament and Council Directive 2000/14/EC on the approximation of the laws of the Member States relating to the noise emission in the environment by equipment for use outdoors — A report produced for the European Commission, December 2001.

British Standards Institution (BSI)

BSI is the national body responsible for preparing British Standards and other standards-related publications, information and services.

BSI is incorporated by Royal Charter. British Standards and other standardization products are published by BSI Standards Limited.

About us

We bring together business, industry, government, consumers, innovators and others to shape their combined experience and expertise into standards-based solutions.

The knowledge embodied in our standards has been carefully assembled in a dependable format and refined through our open consultation process. Organizations of all sizes and across all sectors choose standards to help them achieve their goals.

Information on standards

We can provide you with the knowledge that your organization needs to succeed. Find out more about British Standards by visiting our website at bsigroup.com/standards or contacting our Customer Services team or Knowledge Centre.

Buying standards

You can buy and download PDF versions of BSI publications, including British and adopted European and international standards, through our website at bsigroup.com/shop, where hard copies can also be purchased.

If you need international and foreign standards from other Standards Development Organizations, hard copies can be ordered from our Customer Services team.

Subscriptions

Our range of subscription services are designed to make using standards easier for you. For further information on our subscription products go to bsigroup.com/subscriptions.

With **British Standards Online (BSOL)** you'll have instant access to over 55,000 British and adopted European and international standards from your desktop. It's available 24/7 and is refreshed daily so you'll always be up to date.

You can keep in touch with standards developments and receive substantial discounts on the purchase price of standards, both in single copy and subscription format, by becoming a **BSI Subscribing Member**.

PLUS is an updating service exclusive to BSI Subscribing Members. You will automatically receive the latest hard copy of your standards when they're revised or replaced.

To find out more about becoming a BSI Subscribing Member and the benefits of membership, please visit bsigroup.com/shop.

With a **Multi-User Network Licence (MUNL)** you are able to host standards publications on your intranet. Licences can cover as few or as many users as you wish. With updates supplied as soon as they're available, you can be sure your documentation is current. For further information, email bsmusales@bsigroup.com.

BSI Group Headquarters

389 Chiswick High Road London W4 4AL UK

Revisions

Our British Standards and other publications are updated by amendment or revision.

We continually improve the quality of our products and services to benefit your business. If you find an inaccuracy or ambiguity within a British Standard or other BSI publication please inform the Knowledge Centre.

Copyright

All the data, software and documentation set out in all British Standards and other BSI publications are the property of and copyrighted by BSI, or some person or entity that owns copyright in the information used (such as the international standardization bodies) and has formally licensed such information to BSI for commercial publication and use. Except as permitted under the Copyright, Designs and Patents Act 1988 no extract may be reproduced, stored in a retrieval system or transmitted in any form or by any means – electronic, photocopying, recording or otherwise – without prior written permission from BSI. Details and advice can be obtained from the Copyright & Licensing Department.

Useful Contacts:

Customer Services

Tel: +44 845 086 9001

Email (orders): orders@bsigroup.com

Email (enquiries): cservices@bsigroup.com

Subscriptions

Tel: +44 845 086 9001

Email: subscriptions@bsigroup.com

Knowledge Centre

Tel: +44 20 8996 7004

Email: knowledgecentre@bsigroup.com

Copyright & Licensing

Tel: +44 20 8996 7070

Email: copyright@bsigroup.com



...making excellence a habit.™