

**Resistance welding —
Transformer-rectifier
for welding guns with
integrated
transformers —
Transformer-rectifier
units operating at
1 000 Hz frequency**

ICS 25.160.30; 29.180

Confirmed
September 2010

National foreword

This British Standard is the UK implementation of EN ISO 22829:2008. It is identical with ISO 22829:2007. It supersedes BS ISO 22829:2007 which is withdrawn.

The UK participation in its preparation was entrusted to Technical Committee WEE/29, Resistance welding.

A list of organizations represented on this committee can be obtained on request to its secretary.

This publication does not purport to include all the necessary provisions of a contract. Users are responsible for its correct application.

Compliance with a British Standard cannot confer immunity from legal obligations.

This British Standard was published under the authority of the Standards Policy and Strategy Committee on 30 April 2007

© BSI 2008

ISBN 978 0 580 60666 3

Amendments/corrigenda issued since publication

Date	Comments
30 June 2008	This corrigendum renumbers BS ISO 22829:2007 as BS EN ISO 22829:2008

EUROPEAN STANDARD

EN ISO 22829

NORME EUROPÉENNE

EUROPÄISCHE NORM

March 2008

ICS 25.160.30; 29.180

English Version

**Resistance welding - Transformer-rectifier for welding guns with
integrated transformers - Transformer-rectifier units operating at
1000 Hz frequency (ISO 22829:2007)**

Soudage par résistance - Transformateurs-redresseurs
pour pinces de soudage à transformateur incorporé -
Transformateurs-redresseurs alimentés sous une
fréquence de 1000 Hz (ISO 22829:2007)

Widerstandsschweißen - Transformatoren-Gleichrichter für
Schweißzangen mit integrierten Transformatoren -
Transformator-/Gleichrichtereinheiten mit einer
Arbeitsfrequenz von 1 000 Hz (ISO 22829:2007)

This European Standard was approved by CEN on 7 March 2008.

CEN members are bound to comply with the CEN/CENELEC Internal Regulations which stipulate the conditions for giving this European Standard the status of a national standard without any alteration. Up-to-date lists and bibliographical references concerning such national standards may be obtained on application to the CEN Management Centre or to any CEN member.

This European Standard exists in three official versions (English, French, German). A version in any other language made by translation under the responsibility of a CEN member into its own language and notified to the CEN Management Centre has the same status as the official versions.

CEN members are the national standards bodies of Austria, Belgium, Bulgaria, Cyprus, Czech Republic, Denmark, Estonia, Finland, France, Germany, Greece, Hungary, Iceland, Ireland, Italy, Latvia, Lithuania, Luxembourg, Malta, Netherlands, Norway, Poland, Portugal, Romania, Slovakia, Slovenia, Spain, Sweden, Switzerland and United Kingdom.



EUROPEAN COMMITTEE FOR STANDARDIZATION
COMITÉ EUROPÉEN DE NORMALISATION
EUROPÄISCHES KOMITEE FÜR NORMUNG

Management Centre: rue de Stassart, 36 B-1050 Brussels

Foreword

The text of ISO 22829:2007 has been prepared by Technical Committee ISO/TC 44 "Welding and allied processes" of the International Organization for Standardization (ISO) and has been taken over as EN ISO 22829:2008 by Technical Committee CEN/TC 121 "Welding" the secretariat of which is held by DIN.

This European Standard shall be given the status of a national standard, either by publication of an identical text or by endorsement, at the latest by September 2008, and conflicting national standards shall be withdrawn at the latest by September 2008.

Attention is drawn to the possibility that some of the elements of this document may be the subject of patent rights. CEN [and/or CENELEC] shall not be held responsible for identifying any or all such patent rights.

According to the CEN/CENELEC Internal Regulations, the national standards organizations of the following countries are bound to implement this European Standard: Austria, Belgium, Bulgaria, Cyprus, Czech Republic, Denmark, Estonia, Finland, France, Germany, Greece, Hungary, Iceland, Ireland, Italy, Latvia, Lithuania, Luxembourg, Malta, Netherlands, Norway, Poland, Portugal, Romania, Slovakia, Slovenia, Spain, Sweden, Switzerland and the United Kingdom.

Endorsement notice

The text of ISO 22829:2007 has been approved by CEN as a EN ISO 22829:2008 without any modification.

Contents

Page

1	Scope	1
2	Normative references	1
3	Terms and definitions.....	1
4	Power supply to the transformer-rectifier unit	3
5	Transformer types	3
6	Dimensions.....	4
7	Construction and additional equipment.....	5
8	Marking	6
9	Shipping.....	6
10	Designation	6
11	Tests.....	7
	Annex A (informative) Relationship between output current and duty factor	13
	Annex B (normative) Input voltage timing characteristics	14
	Annex C (normative) Dimensions of transformers	15
	Annex D (normative) Rating plate	24
	Bibliography	26

Resistance welding — Transformer-rectifier for welding guns with integrated transformers — Transformer-rectifier units operating at 1 000 Hz frequency

1 Scope

This International Standard is applicable to transformer-rectifier units as used in electric resistance welding machines operating from a power supply with a frequency of 1 000 Hz, and of a rated value of the input voltage equal to or higher than 500 V. These transformer-rectifier units are primarily used in welding guns with an integrated transformer.

For these transformer units, this International Standard supplements the requirements given in ISO 5826 and ISO 10656, which remain applicable except where amended by this International Standard.

2 Normative references

The following referenced documents are indispensable for the application of this document. For dated references, only the edition cited applies. For undated references, the latest edition of the referenced document (including any amendments) applies.

ISO 5826:1999, *Resistance welding equipment — Transformers — General specifications applicable to all transformers*

ISO 17657-3, *Resistance welding — Welding current measurement for resistance welding — Part 3: Current sensing coil*

ISO 17657-4, *Resistance welding — Welding current measurement for resistance welding — Part 4: Calibration system*

3 Terms and definitions

For the purposes of this document, the following terms and definitions apply.

3.1

transformer-rectifier unit

transformer incorporating a full-wave rectifier in its secondary circuit

3.2

input voltage

U_1

Root-Mean-Square (RMS) value of the voltage applied to the primary terminals of the transformer-rectifier unit

3.3

rated supply voltage

U_{1N}

RMS value of the supply voltage (applied to the primary terminals) for which the transformer-rectifier unit is constructed

**3.4
rectified voltage**

U_{2d}
RMS value of the voltage at the output of the transformer-rectifier unit when a load resistance is connected across the output terminals

**3.5
input current**

I_1
RMS value of the current at the input terminals of the transformer-rectifier unit

**3.6
open circuit input current**

I_{10}
RMS value of the current at the input terminals of the transformer-rectifier unit with the output terminals open circuit

**3.7
permanent input current**

I_{1P}
maximum RMS value of the current at the input terminals of the transformer-rectifier unit with 100 % duty factor ($X = 100\%$), without exceeding the specified temperature limits

NOTE For calculation related to this International Standard, $I_{1P} = I_{2P} / (N1/N2)$, where $(N1/N2)$ is the transformer turns ratio.

**3.8
output d.c.**

I_{2d}
RMS value of the direct current at the output terminals of the transformer-rectifier unit

**3.9
permanent output current**

I_{2P}
maximum RMS value of the output current delivered by the transformer-rectifier unit at 100 % duty factor ($X = 100\%$), without exceeding the specified temperature limits

**3.10
output current on load condition**

I_{2R}
RMS value of the output current delivered by the transformer-rectifier unit with a load resistance R

**3.11
apparent input power**

S_1
power measured at the input terminals of the transformer-rectifier unit, or calculated by $U_1 \times I_1$

**3.12
rated permanent input apparent power**

S_{1P}
rated permanent apparent power calculated by $U_{1N} \times I_{1P}$

3.13
conduction interval

t_{st}

time span within one half-wave of a period of the alternating current of the inverter, in which a voltage has a measured value that is greater than or equal to $\frac{\hat{u}}{2}$, where \hat{u} expresses the amplitude of voltage measured at the output of inverter

NOTE See Annex B.

3.14
non-conduction interval

t_{pt}

time span within one half-wave of a period of the alternating current of the inverter, in which the voltage has a measured value that is less than $\frac{\hat{u}}{2}$

NOTE See Annex B.

3.15
on time

t_s

time during which the current is applied

3.16
off time

t_p

time during which the current is not applied

4 Power supply to the transformer-rectifier unit

The rated voltage supply shall be delivered by an inverter. This inverter shall deliver the rated voltage at a frequency of 1 000 Hz in a waveform to suit the transformer-rectifier unit characteristics.

5 Transformer types

The minimum principal electrical characteristics of a transformer-rectifier unit shall conform to Table 1.

Table 1 — Electrical characteristics

Type	Nominal value of the rectified voltage U_{2d} V	Minimum value of S_{1P} kVA	Minimum permanent output current I_{2P} kA	Minimum output current on load condition I_{2R}^a kA
H1	6,3	36,0	5,0	11
H2	8,4	45,0	5,0	14
J1	6,3	45,0	6,3	18
J2	10,0	68,0	6,3	28
J3	9,3	63,0	6,3	25
J4	12,5	83,0	6,3	32
N1	10,4	64,0	5,7	20
P1	12,2	75,0	5,7	27
S1	8,2	71,0	6,3	25

NOTE Indicated values are RMS values and are given for a cooling liquid flow rate of 6 l/min for types J1, J2, H, N and P, and of 8 l/min for types J3, J4 and S, with a maximum temperature of the cooling liquid at transformer input of 30 °C.

^a $R = 200 \mu\Omega \pm 5\%$ = load resistance.

The manufacturer of transformer-rectifier units shall provide a set of curves showing the maximum output current relative to duty factor and welding time at the rated supply voltage. An example of a set of curves is given in Annex A.

6 Dimensions

The dimensions of the transformer-rectifier unit shall be as given in Table 2 and as illustrated in Annex C.

NOTE According to ISO 10656, there are basically two transformer types:

- H (106 mm × 150 mm × variable length), and
- J (125 mm × 160 mm × variable length).

Table 2 — Dimensions

Dimensions in millimetres

Type	Maximum length L_1	Length between mounting holes L_2	Overall width	Overall height	Output terminals dimensions
H1	270	170	106	150	32 × 32
H2	270	170	106	150	32 × 32
J1	300	190	125	160	32 × 32
J2	300	190	125	160	32 × 32
J3	300	190	125	160	40 × 50
J4	360	250	125	160	40 × 50
N1	400	115	130	190	45 × 50
P1	400	128	125	200	50 × 50
S1	370	279	127	171	51 × 67

7 Construction and additional equipment

7.1 Grounding

The centre point of the secondary coil shall be earthed by a removable link.

7.2 Thermal protection

The transformer and the rectifier shall be equipped with thermostats that each have a normally closed contact. The insulation shall be suitable for the test conditions prescribed in this International Standard. The position of the wiring of these thermostats shall be in accordance with Figures C.1 to C.6. The wiring of primary thermostats shall be sky blue, the wiring of secondary thermostats shall be black and the wiring of rectifier thermostats shall be yellow.

7.3 Protection of the rectifier

The rectifier should be protected against the accumulation of welding spatter and other contamination.

7.4 Output current sensing coil

If the transformer-rectifier unit is equipped with an output current sensing coil, it shall comply with the conditions below.

- The degree of protection of an externally mounted coil shall be IP 55.
- The output shall be $150 \text{ mV/kA} \pm 1,5 \%$ at a load resistor of $1\,000 \Omega \pm 1 \%$ under full sine wave with a 50 Hz frequency, up to $80 \text{ }^\circ\text{C}$. The tolerance after mounting in the transformer-rectifier unit shall be $\pm 3 \%$.

The detector shall be a Rogowski type coil. The internal resistance of the detector shall be 10Ω to 50Ω . White and brown colour coding shall be used for the wiring.

7.5 Output voltage sensing wires

If the transformer-rectifier unit is equipped with output voltage sensing wires, red and dark blue colour coding shall be used for the wiring. The red wire shall be connected to the “+” output terminal, and the dark blue wire to the “-” output terminal.

The wiring shall be protected from short-circuit currents by suitable means, e.g. by fuses, resistors or positive temperature coefficient thermistors.

If a resistor or a positive temperature coefficient thermistor is used, a value of 100 Ω is recommended.

7.6 Mechanical strength

After being tested in accordance with 11.3.6 and 11.3.8, the transformer shall exhibit no visible mechanical damage.

8 Marking

8.1 Primary

The earth and two primary voltage connections shall be clearly identified by means of “U”, “V” and the symbol \oplus (see IEC 60417). The connection to the mid-point of the transformer shall be marked with “MP”.

8.2 Output terminals

The polarity of the output terminals shall be marked on the transformer and on the data sheet with the symbols “+” and “-”, in accordance with Figures C.1 to C.6.

8.3 Rating plate

The rating plate shall conform to Annex D.

9 Shipping

The cooling system shall be drained and the ends plugged. The terminals shall be protected to avoid damage during shipment and storage.

10 Designation

The designation of a transformer-rectifier unit, principally used for welding guns with integrated transformer (robot guns) and complying with the requirements of this International Standard, shall provide the following information, in the order given:

- complete designation (i.e. “Transformer-rectifier unit”);
- reference to this International Standard;
- type of transformer-rectifier unit (e.g. “H1”);
- rectified voltage U_{2d} ;
- minimum permanent output current I_{2P} (see Table 1);

- rated supply voltage U_{1N} and frequency;
- indication of thermal protection T;
- indication of current sensing coil M;
- indication of voltage detector U.

EXAMPLE Transformer-rectifier unit ISO 22829 — H1 — 6,3 — 5,4 — 500/1000 — TMU.

11 Tests

11.1 Type tests

Type testing shall be in compliance with ISO 5826, except where amended by this International Standard.

The following type tests shall be carried out, in the following order:

- general visual examination (preliminary);
- insulation test (preliminary test);
- rectified voltage (U_{2d}), open-circuit input current (I_{1O});
- minimum output current under load condition;
- temperature-rise test;
- dynamic behaviour;
- calibration of the current sensing coil, if appropriate;
- insulation test;
- mechanical strength;
- dielectric test of the transformer-rectifier unit;
- cooling circuit;
- general visual examination (final).

The bandwidth of the reference measuring current and voltage systems shall be at least 100 kHz (-3 dB) and the accuracy class rating shall be 0,5 % of the upper limit of the full scale.

For temperature meters, the accuracy class rating shall be 0,5 % of the full scale.

11.2 Routine tests

The routine tests shall comprise only a reduced set of tests:

- general visual examination;
- dielectric tests;
- rectified voltage (U_{2d});
- cooling circuit.

11.3 Test procedures

11.3.1 General visual examination

Visual examination shall be undertaken to assess visible imperfections. The visual examination performed at the end of the type test procedure shall include the measurement of the dimensions of the transformer-rectifier unit. The dimensions measured shall be reported.

11.3.2 Insulation test

The insulation resistance shall not be less than 50 MΩ.

The conformity shall be checked by applying a direct voltage of 500 V between:

- the input and output connections, and
- the connections and the cover(s).

The output terminals shall be short-circuited during testing to protect the diodes.

11.3.3 Open-circuit tests

The input voltage waveform supplying the test object shall comply with the requirements outlined in Annex B.

The time characteristic shall be chosen such that the period, T , is 1 ms. The conduction time, t_{st} , for the power supply shall be $450 \mu s \pm 1 \%$.

NOTE During the no-load test (when the transformer is connected to the inverter instead of the load resistor), the input voltage waveform is observed with a full conduction time.

During the test, the input voltage shall correspond to $U_{1N} \pm 5 \%$ (rating plate). A load resistor of $R = 10 \Omega \pm 10 \%$ shall be connected across the output connections of the transformer-rectifier unit.

The RMS values of rectified voltage, U_{2d} , at the output connections, and the open circuit input current, I_{10} , shall be measured using an integration time of 60 ms.

The rectified voltage, U_{2d} , shall not deviate by more than $\pm 5 \%$ from the value specified on the rating plate.

At the rated supply voltage, U_{1N} , the open-circuit input current, I_{10} , shall meet the following condition:

$$I_{10} \leq \frac{0,04 \cdot S_{1P}}{U_{1N}} \quad (1)$$

11.3.4 Minimum output current under load condition

The test shall only be started when the temperature difference between the cooling liquid inlet and the cooling liquid outlet is less than 1 K.

The input voltage waveform supplying the test object shall comply with the requirements outlined in Annex B.

The time characteristic shall be chosen such that the period, T , is 1 ms. The conduction time, t_{st} , for the power supply shall be $450 \mu s \pm 1 \%$.

The input voltage, U_1 , shall correspond to $U_{1N} \pm 5 \%$. The input voltage, U_1 , shall be recorded and a correction formulae shall be used if the input voltage, U_1 , is different from U_{1N} . A load resistor of $R = 200 \mu \Omega \pm 5 \%$ shall be connected across the output connections of the transformer-rectifier unit.

The RMS values of the output current, I_{2R} , shall be measured using an integration time of 60 ms.

At the rated supply voltage, U_{1N} , the output current, I_{2R} , shall not be less than the values listed in Table 1.

11.3.5 Cooling circuit test

The cooling liquid pressure drop shall not exceed 100 kPa (1 bar)¹⁾ for types J1, J2, H, N and P, and 160 kPa (1,6 bar) for types J3, J4 and S, when supplied at the nominal flow rate (Q).

The cooling liquid circuit shall be tight at a pressure of 1 000 kPa (10 bar) for 10 min for the type test. This test is not performed during the routine test.

Compliance is checked by leak-tightness and flow check.

11.3.6 Temperature-rise test

The heating rate and maximum temperature shall conform to ISO 5826 up to a duty factor of 20 %, with the exception of the diode surfaces. The test shall be carried out at the rated supply voltage, $U_{1N} \pm 5$ %, with a pulse duration of 240 ms and a duty factor, X , of 20 %.

A load resistor with a resistance value such that the secondary current is limited to $I_{2d} = I_{2P}\sqrt{5}$ shall be installed at the output terminals.

NOTE The term $\sqrt{5}$ is equal to $\sqrt{\frac{100\%}{20\%}}$, 100 % and 20 % being duty factor values.

The welding current shall be measured using an integration time equal to the pulse duration (i.e. 240 ms).

The cooling liquid flow rate shall not exceed 6 l/min for types J1, J2, H, N and P, and 8 l/min for types J3, J4 and S. If the cooling flow rate indicated on the rating plate is lower than 6 l/min for types J1, J2, H, N and P, and 8 l/min for types J3, J4 and S, this value shall be used during testing.

The input voltage waveform supplying the test object shall comply with the requirements in Annex B.

The time characteristic shall be chosen such that the period, T , is 1 ms. The conduction interval, t_{st} , for the power supply shall be $450 \mu\text{s} \pm 1\%$.

The temperature rise of the windings shall not exceed the limit values listed in ISO 5826:1999, Table 2. The temperature rise of the accessible surfaces shall not exceed 65 K.

11.3.7 Dynamic test of the output terminals

The transformer-rectifier shall withstand the dynamic loads produced by a repetitive flow of welding or test current no less than three times the secondary permanent output current, I_{2P} , in the test configuration shown in Figure 1.

The duty cycle shall be 1 % and the weld time shall be 60 ms.

The number of cycles shall be 2 500.

The dimension, a , shall be measured before and after the test has been performed. The deformation of the output terminals shall not cause the dimension, a , to change by more than 20 %.

1) 1 bar = 10^5 N/m^2 = 100 kPa

Dimensions in millimetres

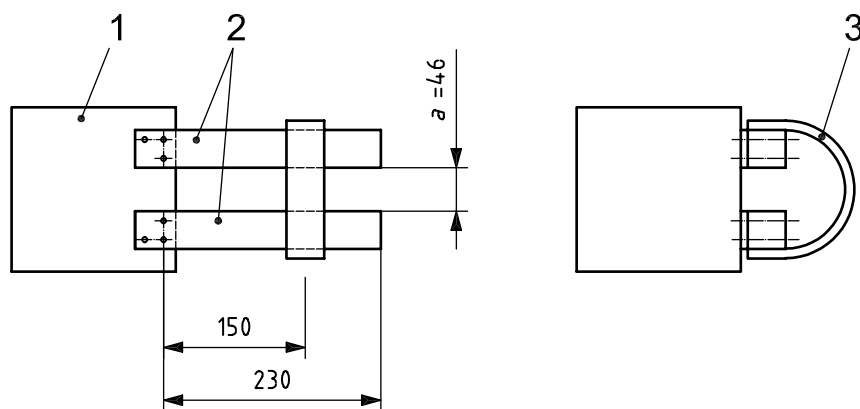

Key

- 1 transformer
- 2 copper bars 30 mm × 30 mm
- 3 flexible shunt

a) Types J1, J2 and H

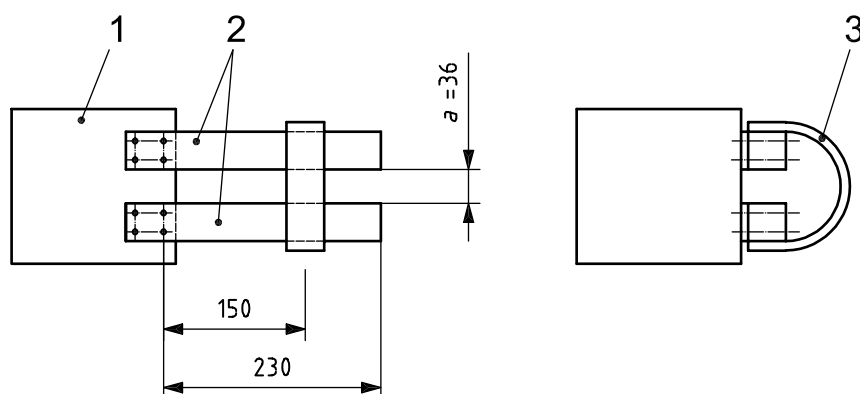

Key

- 1 transformer
- 2 copper bars 40 mm × 40 mm
- 3 flexible shunt

b) Types J3 and J4

Figure 1 (continued)

Dimensions in millimetres

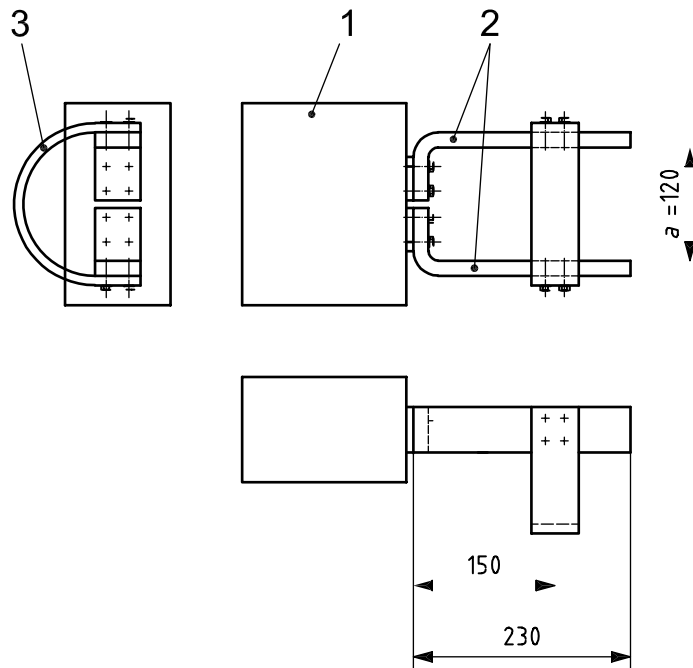

Key

- 1 transformer
- 2 copper bars 20 mm × 50 mm
- 3 flexible shunt

c) Types N and P

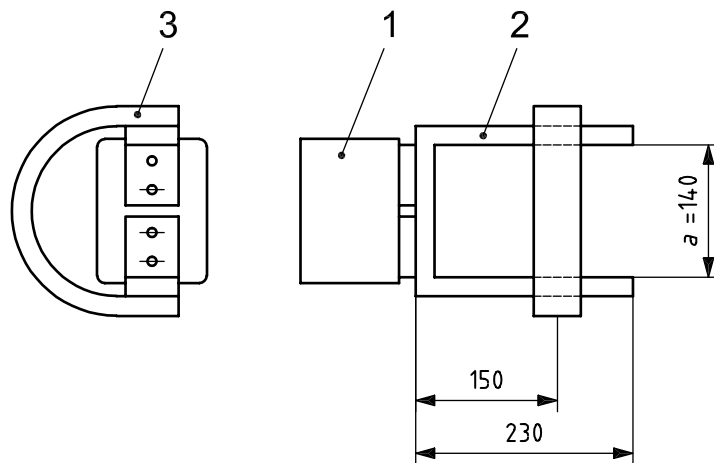

Key

- 1 transformer
- 2 copper bars 25 mm × 60 mm
- 3 flexible shunt

d) Type S

Figure 1 — Dynamic type test set up

11.3.8 Calibration of the output current sensing coil

The test shall be carried out in accordance with ISO 17657-3 and ISO 17657-4.

11.3.9 Mechanical strength

The transformer shall be solidly secured on two plates through the four M8 or M10 mounting holes of two opposite sides. A tensile load of 10 kN shall be progressively applied on both sides, such that the maximum loading is reached after 1 min and maintained for an additional 1 min. The test shall be repeated on the other two sides.

There shall be visible damage after testing.

11.3.10 Dielectric tests

11.3.10.1 Transformer

Before installing the diodes, dielectric tests of the transformer shall be carried out using an a.c. waveform 50/60 Hz, in accordance with ISO 5826.

Voltage shall be gradually increased from zero to the following RMS values:

- between primary and secondary: 4 kV RMS;
- between primary and case: 4 kV RMS;
- between secondary and case: 1 kV RMS.

Each test shall last a minimum of 1 min.

11.3.10.2 Transformer-rectifier unit

Dielectric tests of the transformer-rectifier unit shall be carried out using an a.c. waveform 50/60 Hz on the transformer, in accordance with ISO 5826.

Voltage shall be gradually increased from zero to the following RMS values:

- between primary and output terminal: 2,5 kV RMS;
- between primary and case: 2,5 kV RMS;
- between output terminal and case: 1 kV RMS.

Each test shall last a minimum of 1 min.

The output terminals shall be short-circuited during testing to protect the diodes.

The thermoswitches, the current sensing coil (if applicable) and their connecting circuits shall withstand a test RMS voltage of 1,5 kV for 1 min between them and the primary, secondary and the case.

Annex A (informative)

Relationship between output current and duty factor

Figure A.1 shows an example of a set of curves showing the output current from a transformer-rectifier unit relative to its duty factor for 10 000 000 cycles.

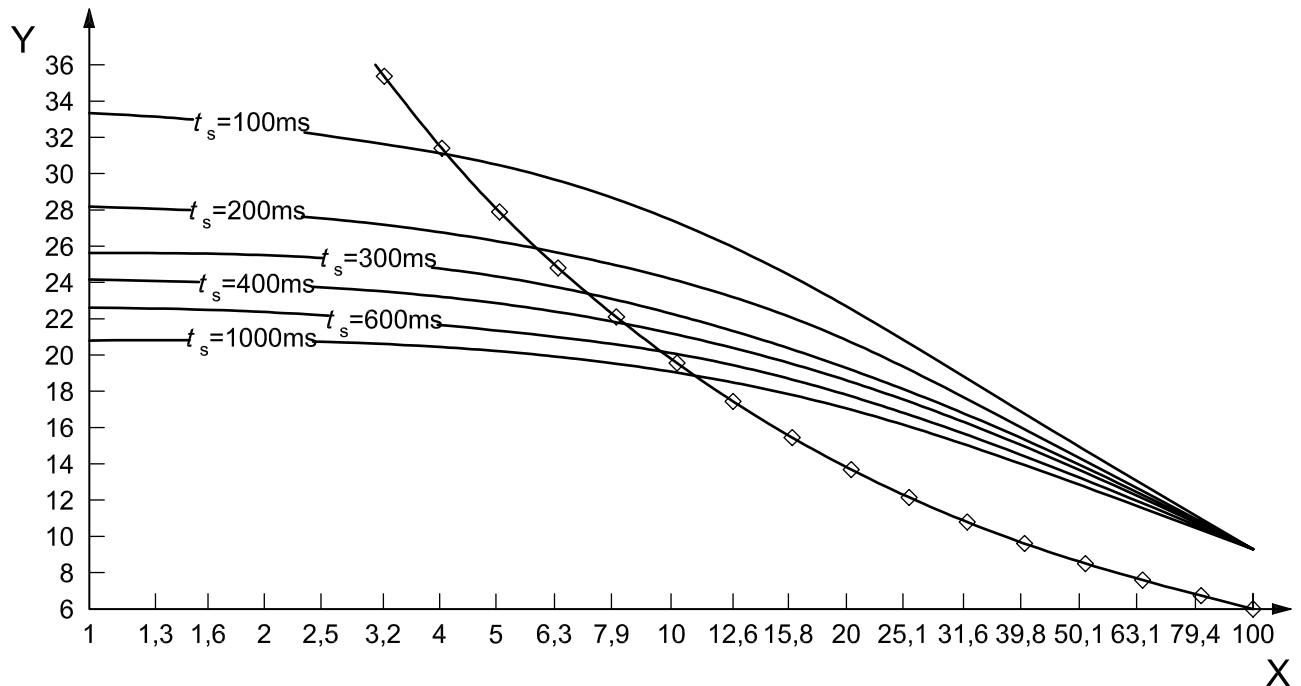

Water flow rate in the transformer: 6 l/min
 Input water temperature: 30 °C
 Permanent output current I_p : 6,3 kA
 Supply voltage: U_{1N}

Key

X duty factor of diodes and transformer, in %
 Y maximum welding current, in kA
 t_s on time

Figure A.1 — Combined duty factor of diodes and transformer — Example of a set of curves for a type J2 unit with an integration period of 2 s

Annex B (normative)

Input voltage timing characteristics

Figure B.1 shows the timing characteristic of the voltage at the output of the inverter which is used to supply the transformer rectifier unit. To set up the timing characteristic, the inverter output terminals are temporarily connected to a low inductance load resistor of $100 \Omega \pm 5 \%$ replacing the transformer rectifier.

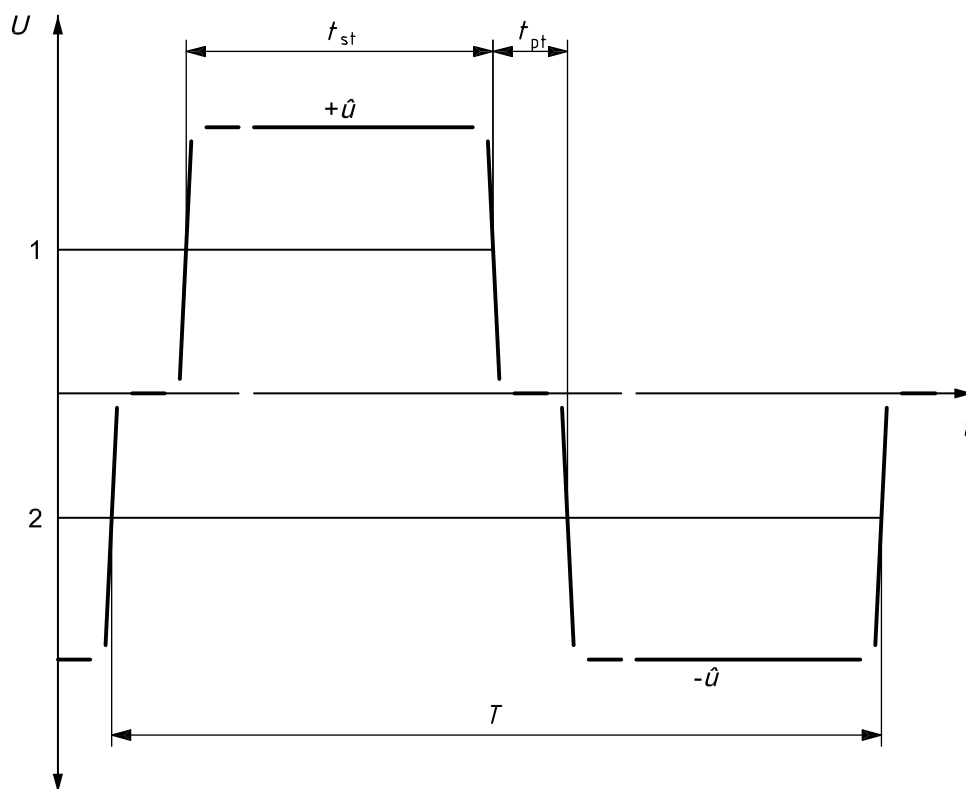

Key

t time, in μs

U voltage at output of inverter, in V

1 measured value of voltage = $\frac{+\hat{u}}{2}$

2 measured value of voltage = $\frac{-\hat{u}}{2}$

t_{pt} non-conduction interval

t_{st} conduction interval

T timing characteristic

\hat{u} amplitude of voltage at output of inverter

Figure B.1 — Characteristic of the voltage at the output of the inverter

Annex C
(normative)

Dimensions of transformers

Dimensions in millimetres

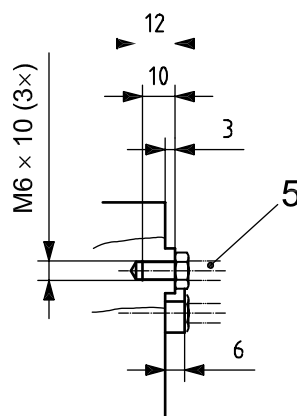
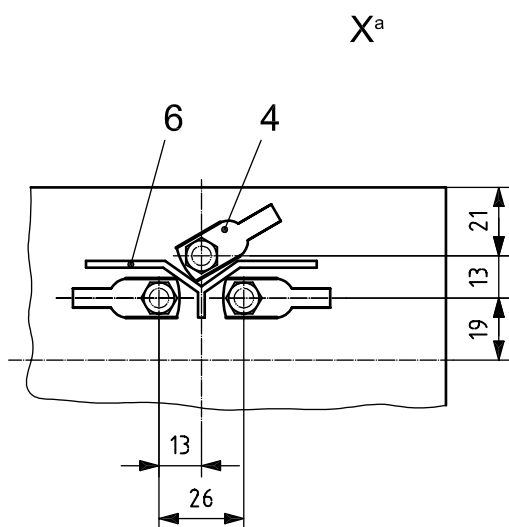
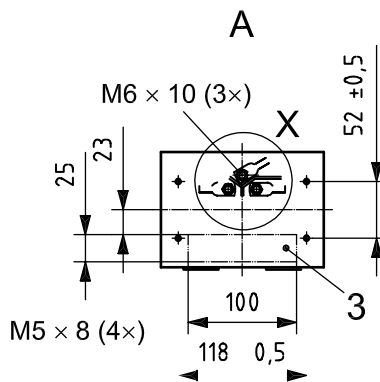
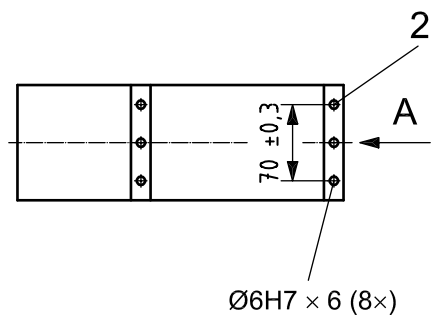
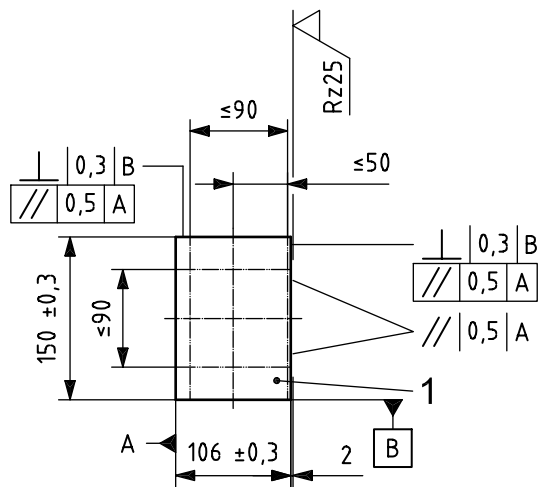
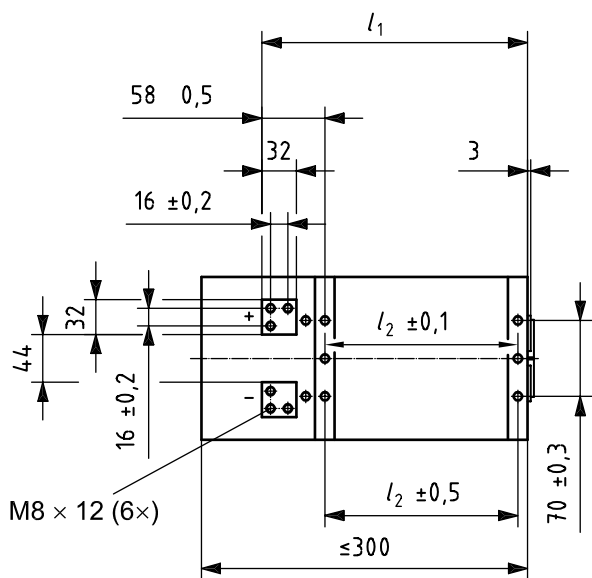

Key

- 1 area, $2 \times \frac{R_p}{4} \times 10$ mm, in which to order connections of cooling circuit
- 2 16 × M8 × 12, fitted with steel inserts ^a
- 3 output area for T, M and U
- 4 Ø 6 mm lug, 10 mm² cable
- 5 Ø 6 mm contact pin
- 6 insulating barrier

^a Wire type insert not acceptable.

Figure C.1 — Dimensions of transformers of types H1 and H2

Dimensions in millimetres

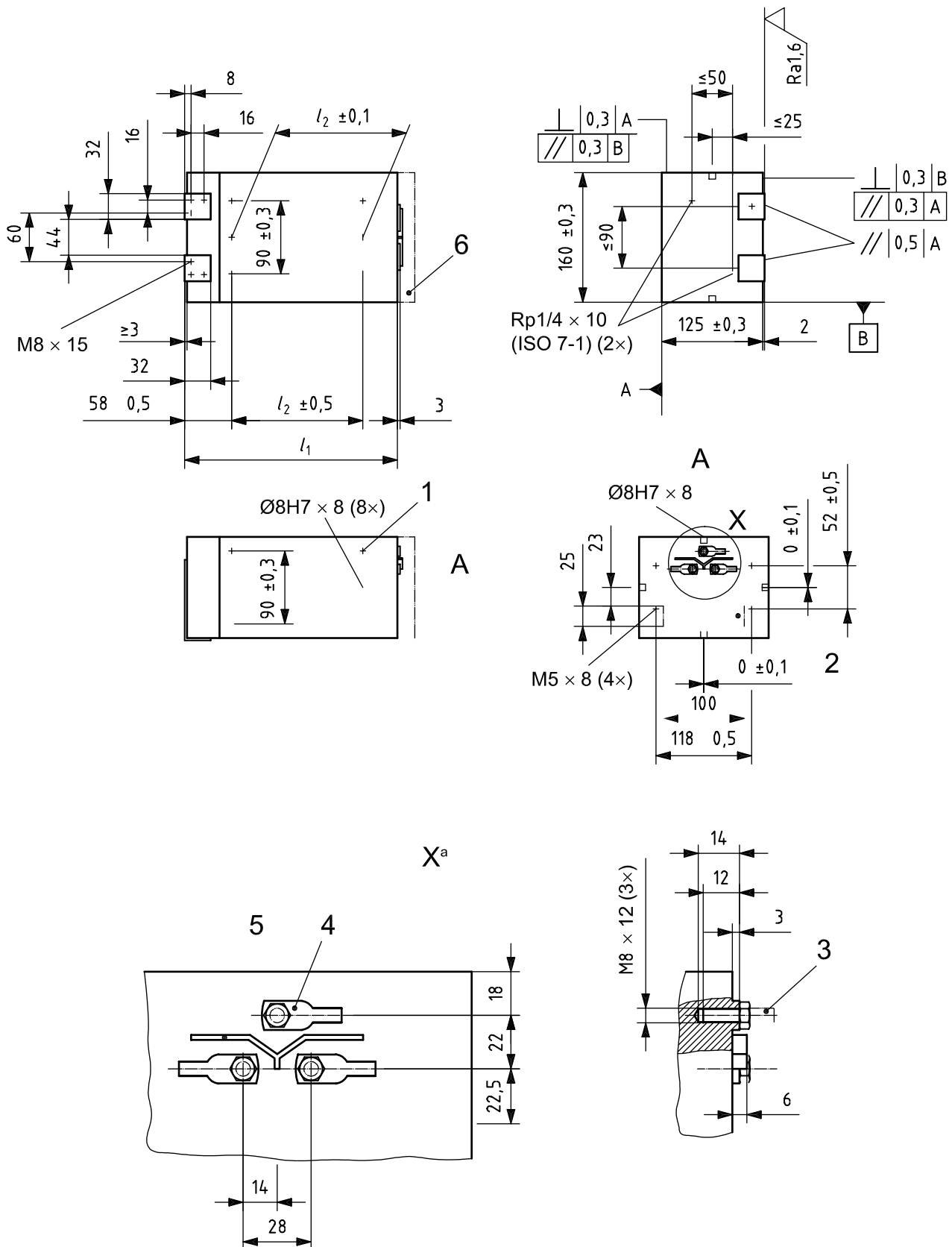

Key

- 1 16 × M10 × 15, fitted with steel inserts ^a
- 2 output area for T, M and U
- 3 Ø 8 mm contact pin
- 4 Ø 8 mm lug, 16 mm² cable
- 5 insulating barrier
- 6 connection box

^a Wire type insert not acceptable.

Figure C.2 — Dimensions of transformers of types J1 and J2

Dimensions in millimetres

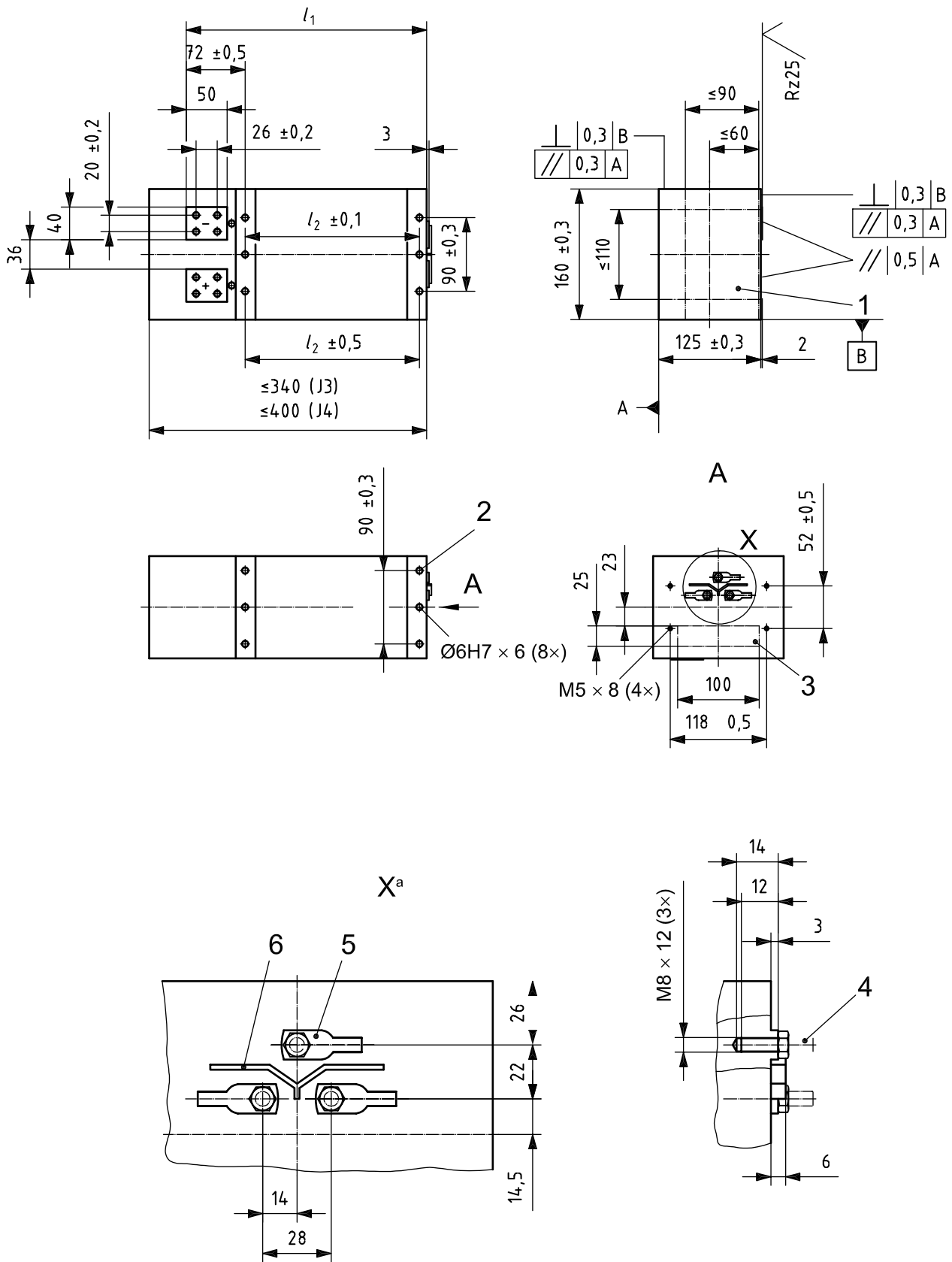

Key

- 1 area, $2 \times \frac{R_p}{4} \times 10$ mm, in which to order connections of cooling circuit
 - 2 16 × M8 × 12, fitted with steel inserts ^a
 - 3 output area for T, M and U
 - 4 Ø 8 mm contact pin
 - 5 Ø 8 mm lug, 16 mm² cable
 - 6 insulating barrier
- ^a Wire type insert not acceptable.

Figure C.3 — Dimensions of transformers of types J3 and J4

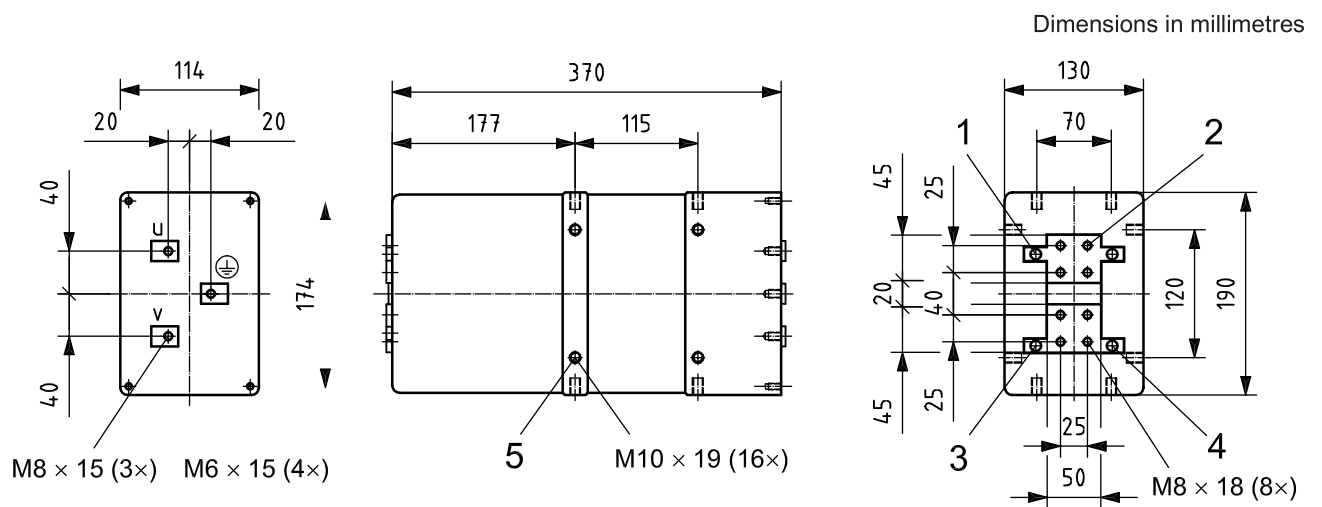

Key

- 1 stack water outlet (RC 1/8)
- 2 stack water inlet (RC 1/8)
- 3 transformer water outlet (RC 1/8)
- 4 transformer water inlet (RC 1/8)
- 5 hericoil inserts

Figure C.4 — Dimensions of transformers of type N1

Dimensions in millimetres

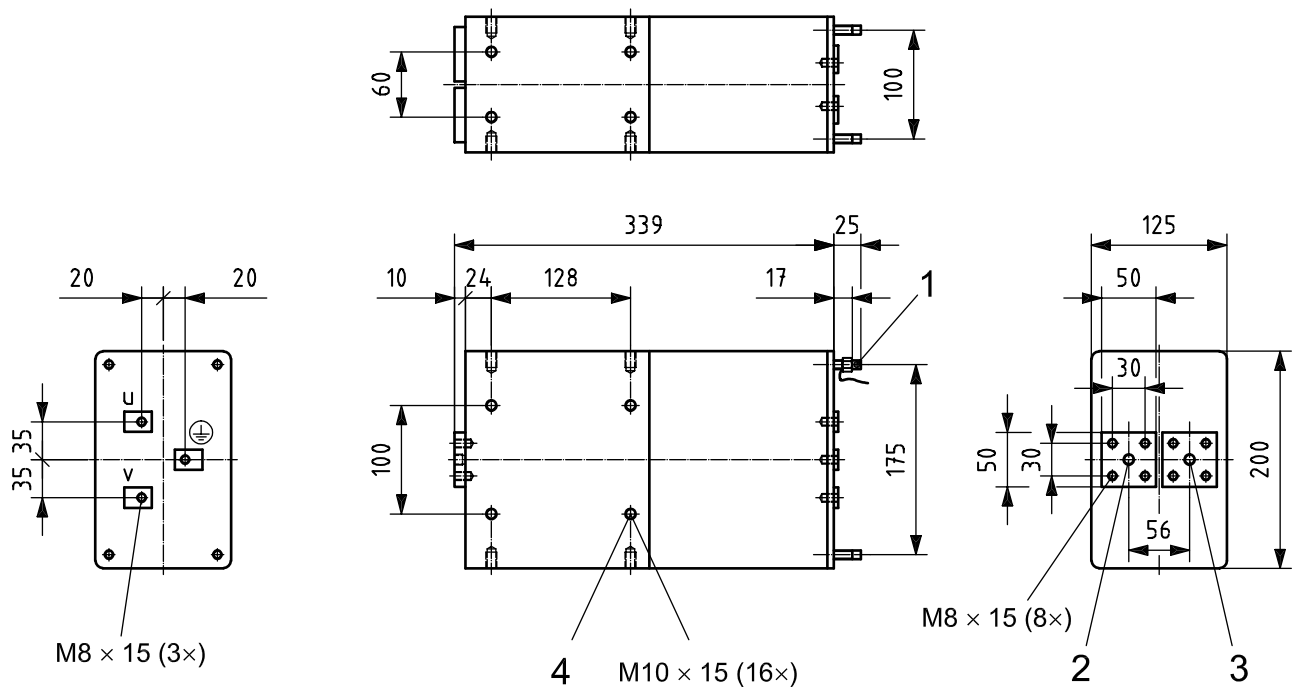

Key

- 1 studs for connector box (4 × M8)
- 2 water outlet (RC 1/4)
- 3 water inlet (RC 1/4)
- 4 hericoil inserts

Figure C.5 — Dimensions of transformers of type P1

Dimensions in millimetres

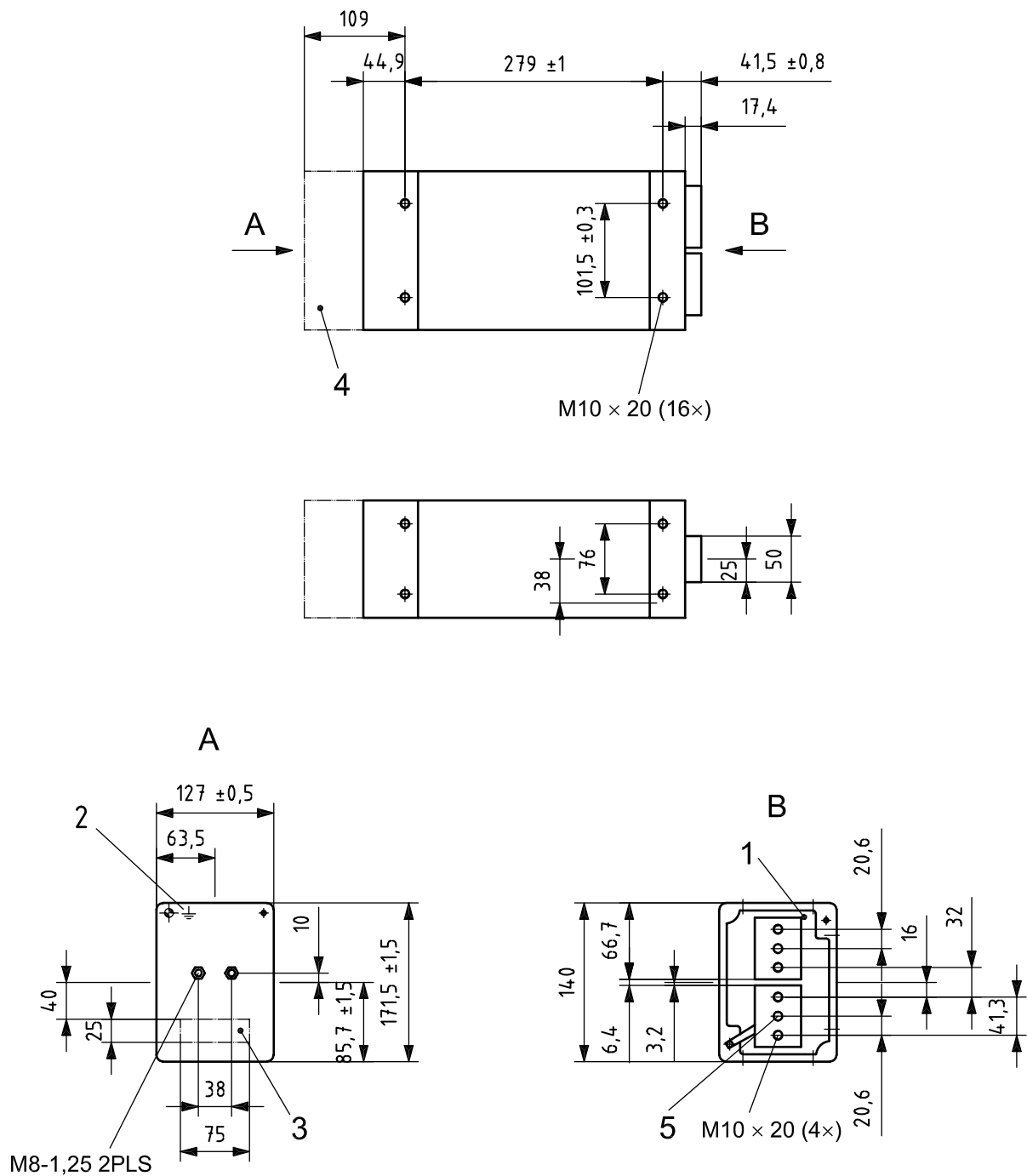

Key

- 1 “+” pad
- 2 case ground, located in primary housing (M6—1.00)
- 3 output area for T, M and U
- 4 connection box
- 5 water connection ^a

^a Use 10 mm I.D.O-ring.

Figure C.6 — Dimensions of transformers of type S1

Annex D (normative)

Rating plate

D.1 General

Figure D.1 gives a schematic illustration of a rating plate. The areas indicated are defined in D.2 to D.4.

1	
2	
3	
4	
5	
6	
7	
8	
9	
10	11
12	13
14	15

Figure D.1 — Schematic illustration of rating plate

D.2 Marking

In Figure D.1, areas 1 to 4 relate to the following:

- area 1: name of the manufacturer or the distributor and, optionally, a trade-mark and country of the manufacturer;
- area 2: type (indication according to the manufacturer's account);
- area 3: manufacturing data (e.g. serial number, construction date, etc.);
- area 4: reference to this International Standard as a confirmation that the transformer-rectifier unit corresponds to its requirements.

D.3 Electrical parameters

In Figure D.1, areas 5 to 9 relate to the following:

- area 5: related supply voltage, or input frequency, U_{1N} , in V/Hz (see 3.3);
- area 6: rated permanent input apparent power, S_{1P} , in kVA (see 3.12);

- area 7: nominal value of the rectified voltage, U_{2d} , in V (see 3.4);
- area 8: permanent output current, I_{2P} , in kA (see 3.9);
- area 9: output current on load condition, I_{2R} , in kA (see 3.10).

D.4 Other parameters

In Figure D.1, areas 10 to 15 relate to the following:

- area 10: rated flow rate of the cooling liquid, Q , in l/min;
- area 11: rated pressure drop of the cooling liquid, Δp , in kPa (bar);
- area 12: insulation class;
- area 13: mass of the transformer-rectifier unit, in kg;
- area 14: turns ratio;
- area 15: additional information, if appropriate (e.g. type code).

Bibliography

- [1] ISO 10656, *Electric resistance welding — Integrated transformers for welding guns*
- [2] IEC 60417, *Graphical symbols for use on equipment*

BSI — British Standards Institution

BSI is the independent national body responsible for preparing British Standards. It presents the UK view on standards in Europe and at the international level. It is incorporated by Royal Charter.

Revisions

British Standards are updated by amendment or revision. Users of British Standards should make sure that they possess the latest amendments or editions.

It is the constant aim of BSI to improve the quality of our products and services. We would be grateful if anyone finding an inaccuracy or ambiguity while using this British Standard would inform the Secretary of the technical committee responsible, the identity of which can be found on the inside front cover. Tel: +44 (0)20 8996 9000. Fax: +44 (0)20 8996 7400.

BSI offers members an individual updating service called PLUS which ensures that subscribers automatically receive the latest editions of standards.

Buying standards

Orders for all BSI, international and foreign standards publications should be addressed to Customer Services. Tel: +44 (0)20 8996 9001. Fax: +44 (0)20 8996 7001. Email: orders@bsi-global.com. Standards are also available from the BSI website at <http://www.bsi-global.com>.

In response to orders for international standards, it is BSI policy to supply the BSI implementation of those that have been published as British Standards, unless otherwise requested.

Information on standards

BSI provides a wide range of information on national, European and international standards through its Library and its Technical Help to Exporters Service. Various BSI electronic information services are also available which give details on all its products and services. Contact the Information Centre. Tel: +44 (0)20 8996 7111. Fax: +44 (0)20 8996 7048. Email: info@bsi-global.com.

Subscribing members of BSI are kept up to date with standards developments and receive substantial discounts on the purchase price of standards. For details of these and other benefits contact Membership Administration. Tel: +44 (0)20 8996 7002. Fax: +44 (0)20 8996 7001. Email: membership@bsi-global.com.

Information regarding online access to British Standards via British Standards Online can be found at <http://www.bsi-global.com/bsonline>.

Further information about BSI is available on the BSI website at <http://www.bsi-global.com>.

Copyright

Copyright subsists in all BSI publications. BSI also holds the copyright, in the UK, of the publications of the international standardization bodies. Except as permitted under the Copyright, Designs and Patents Act 1988 no extract may be reproduced, stored in a retrieval system or transmitted in any form or by any means – electronic, photocopying, recording or otherwise – without prior written permission from BSI.

This does not preclude the free use, in the course of implementing the standard, of necessary details such as symbols, and size, type or grade designations. If these details are to be used for any other purpose than implementation then the prior written permission of BSI must be obtained.

Details and advice can be obtained from the Copyright & Licensing Manager. Tel: +44 (0)20 8996 7070. Fax: +44 (0)20 8996 7553. Email: copyright@bsi-global.com.