

BS EN ISO 22282-4:2012



BSI Standards Publication

# Geotechnical investigation and testing — Geohydraulic testing

## Part 4: Pumping tests

**bsi.**

...making excellence a habit.™

### National foreword

This British Standard is the UK implementation of EN ISO 22282-4:2012. Together with parts 1, 2, 3, 5, and 6 of BS EN ISO 22282, it partially supersedes BS 5930:1999+A2:2010, which is currently being revised in order to remove conflicting material. In the meantime, where conflict arises between these documents, the provisions of BS EN ISO 22282-4:2012 take precedence.

The test given in this standard is included in BS 5930:1999+A2:2010 (Clauses 27 and 28), and conflicting parts are now withdrawn.

The UK participation in its preparation was entrusted by Technical Committee B/526, Geotechnics, to Subcommittee B/526/3, Site investigation and ground testing.

A list of organizations represented on this subcommittee can be obtained on request to its secretary.

This publication does not purport to include all the necessary provisions of a contract. Users are responsible for its correct application.

© The British Standards Institution 2012.  
Published by BSI Standards Limited 2012.

ISBN 978 0 580 76153 9

ICS 91.010.30; 93.020

**Compliance with a British Standard cannot confer immunity from legal obligations.**

This British Standard was published under the authority of the Standards Policy and Strategy Committee on 31 October 2012.

### Amendments/corrigenda issued since publication

Date	Text affected
------	---------------

---

ICS 93.020

English Version

**Geotechnical investigation and testing - Geohydraulic testing -  
Part 4: Pumping tests (ISO 22282-4:2012)**

Reconnaissance et essais géotechniques - Essais  
géohydrauliques - Partie 4: Essais de pompage (ISO  
22282-4:2012)

Geotechnische Erkundung und Untersuchung -  
Geohydraulische Versuche - Teil 4: Pumpversuche (ISO  
22282-4:2012)

This European Standard was approved by CEN on 31 May 2012.

CEN members are bound to comply with the CEN/CENELEC Internal Regulations which stipulate the conditions for giving this European Standard the status of a national standard without any alteration. Up-to-date lists and bibliographical references concerning such national standards may be obtained on application to the CEN-CENELEC Management Centre or to any CEN member.

This European Standard exists in three official versions (English, French, German). A version in any other language made by translation under the responsibility of a CEN member into its own language and notified to the CEN-CENELEC Management Centre has the same status as the official versions.

CEN members are the national standards bodies of Austria, Belgium, Bulgaria, Croatia, Cyprus, Czech Republic, Denmark, Estonia, Finland, France, Germany, Greece, Hungary, Iceland, Ireland, Italy, Latvia, Lithuania, Luxembourg, Malta, Netherlands, Norway, Poland, Portugal, Romania, Slovakia, Slovenia, Spain, Sweden, Switzerland, Turkey and United Kingdom.



EUROPEAN COMMITTEE FOR STANDARDIZATION  
COMITÉ EUROPÉEN DE NORMALISATION  
EUROPÄISCHES KOMITEE FÜR NORMUNG

**Management Centre: Avenue Marnix 17, B-1000 Brussels**

## Foreword

This document (EN ISO 22282-4:2012) has been prepared by Technical Committee CEN/TC 341 "Geotechnical Investigation and Testing", the secretariat of which is held by ELOT, in collaboration with Technical Committee ISO/TC 182 "Geotechnics".

This European Standard shall be given the status of a national standard, either by publication of an identical text or by endorsement, at the latest by December 2012, and conflicting national standards shall be withdrawn at the latest by December 2012.

Attention is drawn to the possibility that some of the elements of this document may be the subject of patent rights. CEN [and/or CENELEC] shall not be held responsible for identifying any or all such patent rights.

According to the CEN/CENELEC Internal Regulations, the national standards organisations of the following countries are bound to implement this European Standard: Austria, Belgium, Bulgaria, Croatia, Cyprus, Czech Republic, Denmark, Estonia, Finland, France, Germany, Greece, Hungary, Iceland, Ireland, Italy, Latvia, Lithuania, Luxembourg, Malta, Netherlands, Norway, Poland, Portugal, Romania, Slovakia, Slovenia, Spain, Sweden, Switzerland, Turkey and the United Kingdom.

<b>Contents</b>	<b>Page</b>
<b>Foreword</b> .....	<b>iv</b>
<b>1 Scope</b> .....	<b>1</b>
<b>2 Normative references</b> .....	<b>1</b>
<b>3 Terms, definitions and symbols</b> .....	<b>2</b>
<b>3.1 Terms and definitions</b> .....	<b>2</b>
<b>3.2 Symbols</b> .....	<b>2</b>
<b>4 Equipment</b> .....	<b>2</b>
<b>5 Test procedure</b> .....	<b>3</b>
<b>5.1 Test preparation</b> .....	<b>3</b>
<b>5.2 Arranging the disposal of discharge water</b> .....	<b>3</b>
<b>5.3 Executing and equipping the well</b> .....	<b>4</b>
<b>5.4 Executing and equipping the piezometers</b> .....	<b>6</b>
<b>5.5 Execution of the test</b> .....	<b>6</b>
<b>5.6 Uncertainty of measurement</b> .....	<b>9</b>
<b>5.7 Interruptions in pumping</b> .....	<b>9</b>
<b>5.8 Decommissioning</b> .....	<b>9</b>
<b>6 Test results</b> .....	<b>9</b>
<b>7 Reports</b> .....	<b>10</b>
<b>7.1 Field report</b> .....	<b>10</b>
<b>7.2 Test report</b> .....	<b>11</b>
<b>Annex A (informative) Record of measured values and test results of the pumping test — Example</b> .....	<b>12</b>
<b>Annex B (informative) Determining the pumping test discharge</b> .....	<b>14</b>
<b>Annex C (informative) Interpretation of the pumping test results</b> .....	<b>18</b>
<b>Bibliography</b> .....	<b>25</b>

## Foreword

ISO (the International Organization for Standardization) is a worldwide federation of national standards bodies (ISO member bodies). The work of preparing International Standards is normally carried out through ISO technical committees. Each member body interested in a subject for which a technical committee has been established has the right to be represented on that committee. International organizations, governmental and non-governmental, in liaison with ISO, also take part in the work. ISO collaborates closely with the International Electrotechnical Commission (IEC) on all matters of electrotechnical standardization.

International Standards are drafted in accordance with the rules given in the ISO/IEC Directives, Part 2.

The main task of technical committees is to prepare International Standards. Draft International Standards adopted by the technical committees are circulated to the member bodies for voting. Publication as an International Standard requires approval by at least 75 % of the member bodies casting a vote.

Attention is drawn to the possibility that some of the elements of this document may be the subject of patent rights. ISO shall not be held responsible for identifying any or all such patent rights.

ISO 22282-4 was prepared by the European Committee for Standardization (CEN) Technical Committee CEN/TC 341, *Geotechnical investigation and testing*, in collaboration with Technical Committee ISO/TC 182, *Geotechnics*, Subcommittee SC 1, *Geotechnical investigation and testing*, in accordance with the Agreement on technical cooperation between ISO and CEN (Vienna Agreement).

ISO 22282 consists of the following parts, under the general title *Geotechnical investigation and testing — Geohydraulic testing*:

- *Part 1: General rules*
- *Part 2: Water permeability tests in a borehole using open systems*
- *Part 3: Water pressure tests in rock*
- *Part 4: Pumping tests*
- *Part 5: Infiltrometer tests*
- *Part 6: Water permeability tests in a borehole using closed systems*

# Geotechnical investigation and testing — Geohydraulic testing —

## Part 4: Pumping tests

### 1 Scope

This part of ISO 22282 establishes requirements for pumping tests as part of geotechnical investigation service in accordance with EN 1997-1 and EN 1997-2.

A pumping test consists in principle of:

- drawing down the piezometric surface of the groundwater by pumping from a well (the test well);
- measuring the pumped discharge and the water level in the test well and piezometers, before, during and after pumping, as a function of time.

This part of ISO 22282 applies to pumping tests performed on aquifers whose permeability is such that pumping from a well can create a lowering of the piezometric head within hours or days depending on the ground conditions and the purpose. It covers pumping tests carried out in soils and rock.

The tests concerned by this part of ISO 22282 are those intended for evaluating the hydrodynamic parameters of an aquifer and well parameters, such as:

- permeability of the aquifer,
- radius of influence of pumping,
- pumping rate of a well,
- response of drawdown in an aquifer during pumping,
- skin effect,
- well storage,
- response of recovery in an aquifer after pumping.

### 2 Normative references

The following referenced documents are indispensable for the application of this document. For dated references, only the edition cited applies. For undated references, the latest edition of the referenced document (including any amendments) applies

ISO 14688-1, *Geotechnical investigation and testing — Identification and classification of soil — Part 1: Identification and description*

ISO 14689-1, *Geotechnical investigation and testing — Identification and classification of rock — Part 1: Identification and description*

ISO 22282-1, *Geotechnical investigation and testing — Geohydraulic testing — General rules*

ISO 22475-1, *Geotechnical investigation and testing — Sampling methods and groundwater measurements — Part 1: Technical principles for execution*

### 3 Terms, definitions and symbols

#### 3.1 Terms and definitions

For the purposes of this document, the terms and definitions given in ISO 22282-1 and the following apply.

##### 3.1.1

##### radius of influence of pumping

$R(t)$   
distance, measured from the axis of the well, beyond which the lowering of the piezometric surface of the groundwater is nil

NOTE In a steady-state condition,  $R(t)$  is constant, and is thus designated by  $R_a$ .

#### 3.2 Symbols

Symbol	Designation	Unit
$D$	drilled diameter of the well	m
$d$	thickness of the aquifer	m
$L$	wetted length of screen of the perforated pipe placed in the well	m
$Q$	flow rate	m <sup>3</sup> /s
$Q_d$	discharge rate, assessed pumping discharge at the end of the well preparation	m <sup>3</sup> /s
$Q_e$	discharge of the pumping test	m <sup>3</sup> /s
$R_a$	radius of influence under steady-state conditions	m
$R(t)$	radius of influence at time ( $t$ )	m
$S$	storage factor	—
$T$	transmissivity	m <sup>2</sup> /s
$t$	time	s
$v$	velocity	—
$a$	slope of the line that characterizes the drawdown in the well	—
$b$	ordinate at the origin of the line that characterizes the drawdown in the well	—
$c$	conventional drawdown unit of the preliminary pump discharge	—
$d_N$	size which may be interpolated from the grading curve, of the square sieve mesh of side $d$ for which the weight percent of undersize is equal to $N$ percent	—
$e$	distance between the bottom of the well and the surface of the unconfined groundwater at rest in an aquifer	m
$k_h$	horizontal permeability coefficient	m/s
$\Delta h$	drawdown of the water level in the well	m
$\Delta h'$	drawdown of the water level in the well after 2 h	m
$\Delta h_f$	drawdown of the water level in the well, set during the preliminary test and not to be exceeded	m
$\Delta h_{\max}$	maximum drawdown of the water level in the well during the pumping test	m

### 4 Equipment

Conducting a pumping test requires the following equipment and instruments:

- a) a test well and piezometers (see ISO 22475-1);



- b) a pump and associated pipework capable of pumping from the test well. The pumps shall be equipped with a suitably long discharge pipe so that the water from the pump is discharged sufficiently far away so that it does not affect the test area. The capacity of the pump shall be sufficient to extract from the well a discharge at least equal to that corresponding to that estimated to achieve the maximum planned drawdown;

NOTE Pumping tests are commonly carried out using electric submersible pumps, installed within the test well. However, depending on conditions, pumping tests can also be carried out using suction pumps located at the surface, airlift equipment, or special dewatering equipment such as wellpoints or eductors.

- c) a system for regulating and measuring the discharge ( $\text{m}^3/\text{s}$ ). Devices for measuring the discharge rate shall be suitably calibrated and shall be accurate for a range of flow rates anticipated during the test;
- d) a system for measuring the water level in the test well and piezometers. The turbulence in the test well caused by pumping shall be considered; the devices shall be capable of measuring water levels over the range of drawdowns anticipated during the test;
- e) a time measuring and/or recording device, reading in seconds.

## 5 Test procedure

### 5.1 Test preparation

#### 5.1.1 General

When preparing a pumping test, there are a number of things to investigate and consider in advance, such as:

- basic information on the ground and groundwater conditions according to ISO 22282-1;
- the required drawdown and/or the required discharge rate during the test;
- the discharge point for the pumped water and its location relative to the test well;
- the duration of the test.

#### 5.1.2 Determining the discharge rate for the pumping test

The discharge rate  $Q_d$  must be estimated to ensure that the test well can yield sufficient water, to allow a pump of appropriate capacity to be selected, and to ensure that the discharge can be accepted at the agreed disposal point.

The discharge rate can be estimated by one or more of the following methods:

- based on the purpose of the test and experience of local conditions;
- by theoretical assessment of the well capacity, according to the method described in Annex B;
- by analysis of information from the preliminary pumping phase, according to the method described in Annex B.

### 5.2 Arranging the disposal of discharge water

The disposal of discharge water shall be in accordance with relevant rules and regulations.

If the discharge water is not disposed of via an engineered sewer network, it shall be disposed of at sufficient distance from the test well that it will not have a significant impact on the observed pattern of groundwater lowering.

### 5.3 Executing and equipping the well

#### 5.3.1 Design of the test well

The test well shall be designed to satisfy the following criteria (see Figure 1):

- of sufficient depth to penetrate below the groundwater level in the strata of interest. If the test well does not fully penetrate the aquifer, it shall penetrate the saturated part of the aquifer to a depth of at least 25 times the well screen diameter with a minimum of 3 m;
- of sufficient drilled diameter to accommodate the necessary filter materials and well screen of sufficient diameter to accommodate pumping equipment of adequate capacity to achieve the required discharge rate;
- with sufficient length and capacity of well screen to ensure that the required discharge rate can be achieved;
- to have appropriate filter material to ensure that the discharge water contains an acceptably low sediment content to avoid the risk of pump damage and ground settlement as a result of the removal of fine particles from the soil. Where the well is constructed in a stable rock, it may be possible to construct a test well without the need for filter material.

The filter material shall be a highly permeable granular material of closely controlled particle size, and be formed of grains of inert minerals in relation to the aquifer groundwater chemistry (e.g. quartz, feldspar). In granular soils, the filter's grading curve shall satisfy the double inequality:

$$5 d_{15 \text{ soil}} \leq d_{15 \text{ filter}} \leq 5 d_{85 \text{ soil}}$$

where  $d_N$  designates the characteristic size of the filter or of the ground in place, such that the mass of the soil fraction passing through a sieve with a square mesh of side  $d$  represents  $N$  % of the total mass of material.

In fine grained soils or where the well screen is equipped with a geotextile mesh designed to act as a filter, the filter material's purpose is to backfill the annular space between the outside of the well screen and the borehole wall. In those circumstances the filter media should be highly permeable coarse sand or fine gravel, with a permeability coefficient at least 100 times that of the soil or rock being tested.

The thickness of the annular space for the filter pack shall be at least 50 mm. The inner diameter of the test well shall be selected according to the purpose.

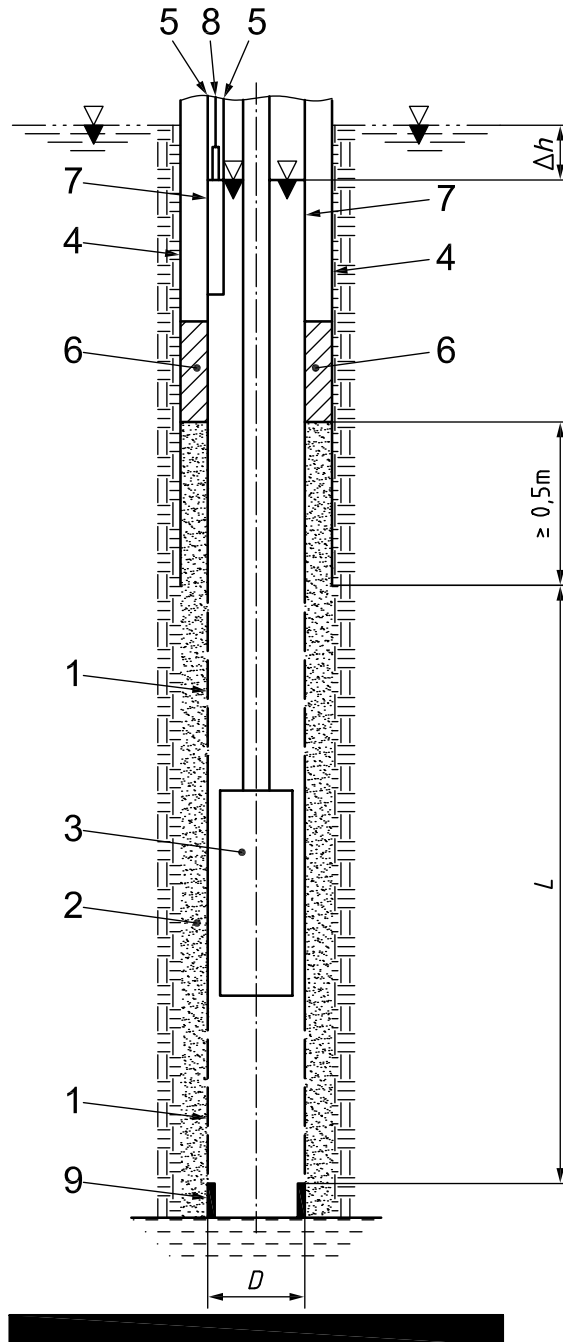

**Key**

- 1 well screen (slotted tube)
- 2 filter material (filter pack)
- 3 submersible pump
- 4 borehole casing
- 5 tube for measuring the water level
- 6 sealing plug
- 7 plain tube
- 8 device for measuring the water level
- 9 base of the screen
- $L$  filter length
- $D$  drilled diameter of the well

**Figure 1 — Test well equipped for a pumping test — Example**

### 5.3.2 Installation procedure

The test well shall be constructed in a similar way to piezometers in accordance with ISO 22475-1. Great care shall be taken when installing the well materials. Particular attention shall be paid to the following:

- The well screen shall be lowered into the borehole to the specified level and shall be installed centrally in the well, with the top and bottom of the screen located at the design level. Care shall be taken that the joints of the screen and casing do not leak, and that the screen and casing are installed vertically and straight.
- If necessary, filter material shall be inserted in the annular space between the screen and the temporary casing (or borehole wall). The filter material shall be placed progressively in stages to reduce the risk of a blockage in the annular space. The filter material shall preferably be placed via a tremie pipe.
- If necessary, a sealing plug of low permeability material (such as bentonite) shall be created in the annular space between the borehole wall and the well casing immediately above the filter material. The purpose of the sealing plug is to prevent infiltration of surface water, or water from other aquifers, into the well screen.

### 5.3.3 Preparation of the well

Prior to the pumping test the well shall be developed to increase the permeability of the soil around the shell by washing, and to remove any drilling residues and mobile soil particles that could be entrained by the water flow into the well. Such particles could clog the filter and damage the test pump.

Development shall be carried out by means of pumping. Possible methods include airlifting or pumping using a robust pump that is not damaged by the presence of particles in the discharge water. If airlift pumping is used, care shall be taken to avoid injecting air into the ground, as air bubbles in the ground can affect the permeability.

Other methods for well development may be used in combination with pumping, including:

- jetting with water inside the well screen;
- surging or swabbing inside the well screen to induce water flow into and out of the well;
- chemical treatment (e.g. use of acids in carbonate rocks).

## 5.4 Executing and equipping the piezometers

### 5.4.1 Installation procedure

Piezometers shall be installed in accordance with ISO 22475-1.

The piezometer tubes shall be installed at such a depth that the influence of the test well can be observed and recorded adequately. Where possible, the piezometer closest to the test well shall be located at the same depth as the bottom of the test well.

### 5.4.2 Preparation of piezometers

Before commencement of the test, piezometers shall be cleaned in accordance with ISO 22475-1. The water level in the piezometers shall be measured for a period before and after the test in order to find any natural variations in the groundwater level. Their response time shall be checked by watching the water rise in the piezometer tube. The period of monitoring depends on the nature of the aquifer and the purpose of the pumping test.

## 5.5 Execution of the test

### 5.5.1 General

The test comprises up to four phases:

- a pre-pumping phase to monitor the undisturbed groundwater levels;

- a preliminary pumping phase to determine the discharge from the pumping test;
- the pumping test phase;
- the post-pumping test phase to monitor recovery of groundwater levels.

### 5.5.2 Pre-pumping monitoring

Prior to commencement of the pumping phase of the test, water levels in the test well and piezometers shall be monitored to determine natural groundwater levels.

NOTE The duration of the pre-pumping phase depends on the purpose of the test and local conditions. Typical durations of pre-pumping monitoring are between one day and ten days. Longer periods of pre-pumping monitoring are necessary when groundwater levels are subject to tidal or other variations.

### 5.5.3 Preliminary pumping phase

Prior to the main pumping test a short period of pumping shall be carried out to test the equipment.

NOTE Suitable durations for the equipment test are between 15 min and 2 h.

During the preliminary pumping phase the correct functioning of pumps, control systems, valves, flow measurement devices and water level measurement devices shall be checked. Discharge pipe work shall be checked for leaks. Any corrective action deemed necessary shall be taken prior to commencement of the pumping test.

For large-scale or complex pumping tests, the preliminary pumping phase can be used to provide information on discharge rate and drawdown to assist in determination of discharge rate for the pumping test (see Annex B).

### 5.5.4 Pumping test

The pumping test shall not be started until water levels in the test well and the piezometers have stabilized following the preliminary pumping phase.

The pumping test can comprise:

- a variable rate test. This type of test involves pumping the test well in a step-wise fashion, either increasing or decreasing, up to the maximum capacity of the test well or the pump. A variable rate test can be used to assist in determination of the discharge rate for a constant rate test;

and/or

- a constant rate test. This type of test involves pumping the test well at a constant rate for the duration on the test.

If the pumping test comprises a variable rate test followed by a constant rate test, there may be a period of post pumping monitoring following the end of the variable rate test. In this case, the period between the end of the variable rate test and the beginning of the constant rate test should be long enough to allow water levels to stabilize.

Whenever the discharge is started or changed, the change in pumping rate shall be carried out rapidly. At the start of the pumping test the discharge rate shall be stabilized within 2 min after starting the pumping.

The time at the start of the test is defined as  $t = 0$ .

During the pumping test measurements of water level shall be made according to the requirements of the purpose of the test and the ground conditions. In general, measurements shall be taken more frequently at the start of the pumping test, or when flow rate has been changed during a variable rate test, when water levels are likely to be changing rapidly. During the later stages of a pumping test, when water levels are changing more slowly, readings can be taken less frequently.

The following time increments between readings should be used unless alternative time increments can be justified based on the purpose of the test and the ground conditions. If the groundwater levels in the test well

and piezometers are likely to continue to change at a significant rate, it may be necessary to take readings more frequently than the guidelines below:

- $\leq 30$  s for  $t \leq 5$  min;
- $\leq 1$  min for  $t = 5$  min to 15 min;
- $\leq 5$  min for  $t = 15$  min to 30 min;
- $\leq 10$  min for  $t = 30$  min to 1 h;
- $\leq 30$  min for  $t = 1$  h to 4 h;
- $\leq 1$  h for  $t > 4$  h.

Where a pumping test is carried out in conditions where groundwater is subject to tidal variations, water level readings shall be taken at frequent intervals throughout the test duration. In tidal conditions the interval between readings should not exceed 15 min.

The pump discharge shall be measured at least four times in the first hour. If the discharge is stable, the discharge can be measured once a day. If the discharge is not stable, the pump discharge shall be determined each hour.

Levels of open water bodies in the vicinity of the test site, where variation is likely to interfere with the pumping test (and vice versa), shall be recorded periodically throughout the test.

Pumping shall be continued until the end of the specified pump test period or, if the test is required to achieve steady-state conditions, until three successive readings, spaced at least 1 h apart, of the water levels in the piezometers do not differ from one another by more than 1 cm.

#### **5.5.5 Post-pumping monitoring**

When pumping is stopped at the end of the pumping phase, post-pumping monitoring shall commence. During this phase, the water levels in the well and piezometers shall be recorded. Starting from the beginning of the post-pumping phase, the intervals between readings should be the same as during the pumping phase.

The duration of the post-pumping phase will depend on the purpose of the test and the local conditions. Unless justified by the purpose of the test and the ground conditions, monitoring time shall be at least equal to the duration of decreasing groundwater levels in the pumping phase, or until three successive readings, spaced at least 1 h apart, do not differ from one another by more than 1 cm.

Once readings are less frequent, the pumping equipment may be removed by keeping the monitoring equipment in operation, provided that monitoring is not disturbed.

Backflow should be avoided.

## 5.6 Uncertainty of measurement

The uncertainty of automatic measurement shall, and of manual measurement should, not be greater than:

- 1 s for time or 1 % of the time increment, whatever gives the greater value;
- 1 cm for levels;
- 5 % of the maximum flow for discharges.

## 5.7 Interruptions in pumping

During the pumping test phase it is important that pumping be continuous, other than equipment shut downs for periodic maintenance. During a variable rate test or the first 24 h of a constant rate test, there shall be no equipment shut downs for maintenance. All pumping plants should be adequately maintained and serviced before the test commences.

If mechanical breakdown or other problems cause interruption to pumping during a variable rate test or during the first 24 h of a constant discharge rate test, the test shall be abandoned. Groundwater levels shall be allowed to recover and the test restarted from  $t = 0$  for a constant rate test, or from the start of the previous step for a variable rate test.

Once a constant rate test has been in progress for more than 24 h, interruptions in pumping of up to 1 hr may be acceptable depending on the purpose of the test, although any interruptions in pumping should be kept to an absolute minimum.

## 5.8 Decommissioning

After the test has been completed, the pumping and monitoring equipment shall be removed. The test well and piezometers shall be locked, backfilled or grouted up according to ISO 22475-1.

## 6 Test results

The principal test results are:

- drawdown and recovery of water levels in the test well and piezometer as a function of time;
- discharge from the test well as a function of time.

During the test, the test results should be plotted graphically.

The test results can be used to evaluate aquifer properties (including permeability, transmissivity, storage coefficient) and the performance parameters of the test well.

For constant rate tests, analyses can be either steady-state or transient-state. Steady-state analyses are relatively simple to apply, but do not allow storage coefficients to be determined. Transient-state analyses are more complex, but allow a wider range of parameters to be determined.

The most common methods of analysis of test results are described in Annex C.

## 7 Reports

### 7.1 Field report

#### 7.1.1 General

At the project site, a field report shall be completed. This field report shall consist of the following, if applicable:

- a) summary log according to ISO 22475-1;
- b) drilling record according to ISO 22475-1;
- c) sampling record according to ISO 22475-1;
- d) record of installation of wells and piezometers according to ISO 22475-1;
- e) record of identification and description of soil and rock according to ISO 14688-1 and ISO 14689-1;
- f) installation record according to 7.1.2;
- g) calibration record according to ISO 22282-1;
- h) decommissioning record;
- i) record of measured values and test results according to 7.1.3.

All field investigations shall be reported such that third persons are able to check and understand the results.

#### 7.1.2 Installation record

The installation record shall be attached to the summary log and include the following essential information, if applicable:

- a) type of equipment;
- b) test well;
- c) piezometers;
- d) pumps;
- e) water level measuring unit;
- f) flow rate measuring unit;
- g) dates and times of installation;
- h) groundwater levels before and after installation;
- i) name and signature of the test operator.

#### 7.1.3 Record of measured values and test results

The record of measured values and test results shall be attached to the summary log and include the following essential information, if applicable (see also Annex A):

- a) name of the enterprise performing the test;
- b) name of the client;
- c) test date(s) and time;
- d) name and number of project;



- e) number of wells and piezometers;
- f) a reference to this International Standard, i.e. ISO 22282-4;
- g) elevation of the water and its depth in the well before the start of pumping;
- h) a table showing, in terms of elapsed time since the beginning of the test, the discharge rates and the water levels measured in the well and in each piezometer;
- i) name and signature of the test operator.

## **7.2 Test report**

The test report shall include the following essential information:

- a) the field report (in original and/or computerized form);
- b) a graphical presentation of the test results;
- c) the name and signature of the responsible expert.

## Annex A (informative)

### Record of measured values and test results of the pumping test — Example

#### A.1 Variable rate discharge test

REPORT: Pumping test			Variable rate discharge test conducted according to ISO 22282-4															
Enterprise:	$Q_d =$	m <sup>3</sup> /s	Date:									File No.:						
Test operator:	$Q_1 =$	m <sup>3</sup> /s	Start time:									Site:						
	$Q_2 =$	m <sup>3</sup> /s	Test well:					Bottom: screen					Top: screen					
	$Q_3 =$	m <sup>3</sup> /s																
	$Q_4 =$	m <sup>3</sup> /s																
STEP No.	$t$	min	0	0,5	1	1,5	2	2,5	3	3,5	4	4,5	5	6	7	8	9	
TEST WELL	$h$	m																
	$\Delta h$	m																
	$Q$	m <sup>3</sup> /s																
	$t$	min	10	11	12	13	14	15	20	25	30	40	50	60	90	120		
TEST WELL	$h$	m																
	$\Delta h$	m																
	$Q$	m <sup>3</sup> /s																
STEP No.	$t$	min	0	0,5	1	1,5	2	2,5	3	3,5	4	4,5	5	6	7	8	9	
TEST WELL	$h$	m																
	$\Delta h$	m																
	$Q$	m <sup>3</sup> /s																
	$t$	min	10	11	12	13	14	15	20	25	30	40	50	60	90	120		
TEST WELL	$h$	m																
	$\Delta h$	m																
	$Q$	m <sup>3</sup> /s																
STEP No.	$t$	min	0	0,5	1	1,5	2	2,5	3	3,5	4	4,5	5	6	7	8	9	
TEST WELL	$h$	m																
	$\Delta h$	m																
	$Q$	m <sup>3</sup> /s																
	$t$	min	10	11	12	13	14	15	20	25	30	40	50	60	90	120		
TEST WELL	$h$	m																
	$\Delta h$	m																
	$Q$	m <sup>3</sup> /s																

## A.2 Pumping test — Example

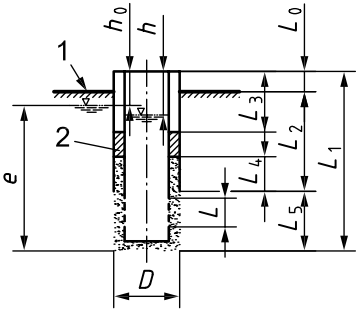
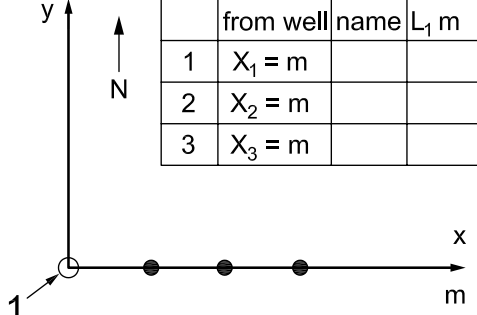
<b>REPORT: Pumping test</b>						File No.:																						
						Site:																						
Conducted according to ISO 22282-4																												
<b>TEST WELL:</b> Ground level          m <b>WELL DIAGRAM</b> 			TEST PHASE (delete as appropriate)			<div style="text-align: center;"> <b>PIEZOMETERS</b> <table border="1" style="margin: 0 auto; border-collapse: collapse;"> <thead> <tr> <th>No.</th> <th>Distance from well</th> <th>BH name</th> <th>Base screen L<sub>1</sub> m</th> </tr> </thead> <tbody> <tr> <td>1</td> <td>X<sub>1</sub> = m</td> <td></td> <td></td> </tr> <tr> <td>2</td> <td>X<sub>2</sub> = m</td> <td></td> <td></td> </tr> <tr> <td>3</td> <td>X<sub>3</sub> = m</td> <td></td> <td></td> </tr> </tbody> </table> </div> <div style="margin-top: 20px;">  </div>							No.	Distance from well	BH name	Base screen L <sub>1</sub> m	1	X <sub>1</sub> = m			2	X <sub>2</sub> = m			3	X <sub>3</sub> = m		
			No.	Distance from well	BH name								Base screen L <sub>1</sub> m															
			1	X <sub>1</sub> = m																								
			2	X <sub>2</sub> = m																								
			3	X <sub>3</sub> = m																								
			Pre-pumping/preliminary/pumping/post-pumping																									
			<b>DRILLING</b>																									
Height of wellhead L <sub>0</sub> =          m																												
Depth of base L <sub>1</sub> =          m																												
<b>WELL CASING</b>																												
Internal diameter:          m																												
Depth of base L <sub>2</sub> :          m																												
Depth of seal L <sub>3</sub> :          m																												
Filter length L <sub>4</sub> :          m																												
<b>WELL SCREEN</b>																												
Internal diameter =          m																												
Length =          m																												
<b>PUMP</b>																												
Diameter =          m																												
<b>Key</b> 1 ground surface 2 seal			<b>Key</b> 1 well axis Diagram of piezometer placements																									
Start of pumping						Date:		End of pumping				Date:																
Time:						Time:		Time:				Time:																
<b>ELAPSED TIME</b>	<i>t</i>	min	0	0,5	1	1,5	2	2,5	3	3,5	4	4,5	5	6	7	8	9											
<b>WELL</b>	<i>h</i>	min																										
	$\Delta h = h - h_0$	m																										
	<i>Q</i>	m <sup>3</sup> /s																										
<b>PIEZO X<sub>1</sub></b>	<i>h</i> <sub>x1</sub>	m																										
	$\Delta h_{x1} = h_{x1} - h_{x1.0}$	m																										
<b>PIEZO X<sub>2</sub></b>	<i>h</i> <sub>x2</sub>	m																										
	$\Delta h_{x2}$	m																										
<b>PIEZO X<sub>3</sub></b>	<i>h</i> <sub>x3</sub>	m																										
	$\Delta h_{x3}$	m																										
<b>PUMPING</b>	<i>t</i>	min	10	11	12	13	14	15	20	25	30	40	50	60	90	120	150											
<b>WELL</b>	<i>h</i>	min																										
	$\Delta h = h - h_0$	m																										
	<i>Q</i>	m <sup>3</sup> /s																										
<b>PIEZO X<sub>1</sub></b>	<i>h</i> <sub>x1</sub>	m																										
	$\Delta h_{x1}$	m																										
<b>PIEZO X<sub>2</sub></b>	<i>h</i> <sub>x2</sub>	m																										
	$\Delta h_{x2}$	m																										
<b>PIEZO X<sub>3</sub></b>	<i>h</i> <sub>x3</sub>	m																										
	$\Delta h_{x3}$	m																										
	$\Delta h_{x3} = h_{x3} - h_{x3.0}$	m																										
Enterprise						Test operator																						

## Annex B (informative)

### Determining the pumping test discharge

#### B.1 General

The discharge rate  $Q_d$  should be estimated to ensure that the test well can yield sufficient water, to allow a pump of appropriate capacity to be selected, and to ensure that the discharge can be accepted at the agreed disposal point.

The discharge rate can be estimated by one or more of the following methods:

- based on the purpose of the test and experience of local conditions;
- by theoretical assessment of the well capacity, according to the method described in this annex;
- by analysis of information from the preliminary pumping phase, according to the method described in this annex.

#### B.2 Theoretical assessment of well capacity

The maximum discharge rate can be set to ensure that:

- the velocity at the entry to the filter given in Equation (B.1):

$$v = \frac{Q_d}{\pi DL} \quad (\text{B.1})$$

is no greater than 1 cm/s;

- the depth of water above the pump inlet is more than 0,5 m;
- the drawdown for a discharge of 0,2  $Q_d$  can be accurately measured using the equipment proposed.

#### B.3 Analysis of information from the preliminary pumping phase

##### B.3.1 General

To determine the appropriate discharge rate to be used in the pumping test a preliminary pumping phase can be carried out.

##### B.3.2 Determining the well's characteristic curve

The characteristic curve of the drawdown  $\Delta h$  in the well, for a pumping period at a fixed discharge  $Q$ , is given by Equation (B.1):

$$\Delta h = aQ^2 + bQ \quad (\text{B.2})$$

The coefficients  $a$  and  $b$  are calculated from the data collected during the preliminary pumping phase.

### B.3.3 Preliminary pumping in the well

The preliminary phase consists of pumping with four successive steps at constant discharge in each step for a duration of 2 h for the first stage, and 1 h for the next three.

The discharges selected for the four steps are a function of the maximum discharge rate that can be obtained from the well  $Q_d$  and are such that:

$$Q_i = 0,8 Q_d / (5 - i) \quad (\text{B.3})$$

where  $i$  is step 1 to step 4.

For each step, the water level in the well is measured at least every 5 min during the first 30 min, and then every 10 min thereafter.

During the first pumping step at discharge  $Q_1$ , the specific drawdown  $(\Delta h/Q)$  of the water level in the well as a function of time allows us to calculate:

- the slope  $\alpha$  of the tangent to the curve giving the specific drawdown plotted against  $\log_{10}$  of time, for a pumping maintained for 2 h;
- the specific drawdown  $c = (\Delta h/Q_1)_{(48 \text{ hr})}$  for pumping at discharge  $Q_1$  whose duration has been extrapolated logarithmically to 48 h.

### B.3.4 Determining coefficients $a$ and $b$ of the well's characteristic curve

Coefficient  $a$  is the slope of the mean straight line passing through the coordinate points  $(Q_i, \Delta h'_i/Q_i)$  calculated for the four steps of index  $i$  (see Figure B.2).  $\Delta h'_1$  is the drawdown measured after 2 h at discharge  $Q_1$  ( $\Delta h'_1 = \Delta h_1$ ).

For the other steps,  $\Delta h'_i$  is the drawdown extrapolated for discharges  $Q_i$  maintained constant for 2 h. It is determined as follows:

- for the step at discharge  $Q_2$  having produced a drawdown  $\Delta h_2$  at the end of 1 h:

$$\Delta h'_2 = \Delta h_2 + \alpha (0,3 Q_2 - 0,48 Q_1) \quad (\text{B.4})$$

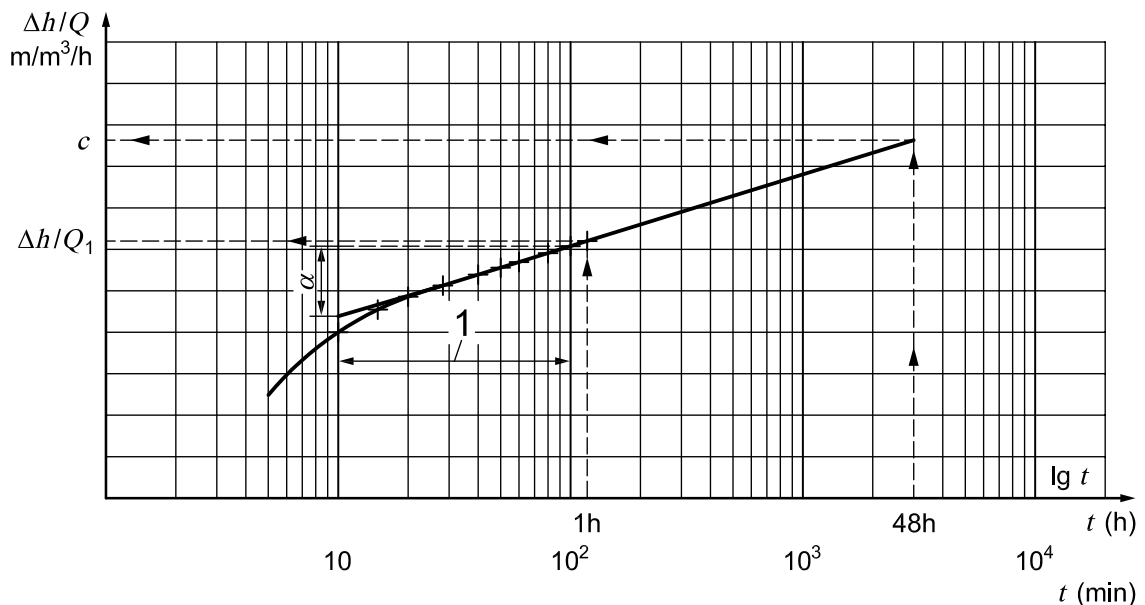

Figure B.1 — Step pumping test — Specific drawdown as a function of time during the first step — Example

— for the step at discharge  $Q_3$  having produced a drawdown  $\Delta h_3$  at the end of 1 h:

$$\Delta h'_3 = \Delta h_3 + 0,3 \alpha (Q_3 - Q_2 - Q_1) \quad (\text{B.5})$$

— for the step at discharge  $Q_4$  having produced a drawdown  $\Delta h_4$  at the end of 1 h:

$$\Delta h'_4 = \Delta h_4 + \alpha [0,3 Q_4 - 0,3 Q_3 - 0,18 Q_2 - 0,22 Q_1] \quad (\text{B.6})$$

where

- $\alpha$  is as determined in B.3.3;
- $b$  is the ordinate at the start of the straight line passing through the point with coordinates  $(Q_1, C)$ . See Figure B.2.

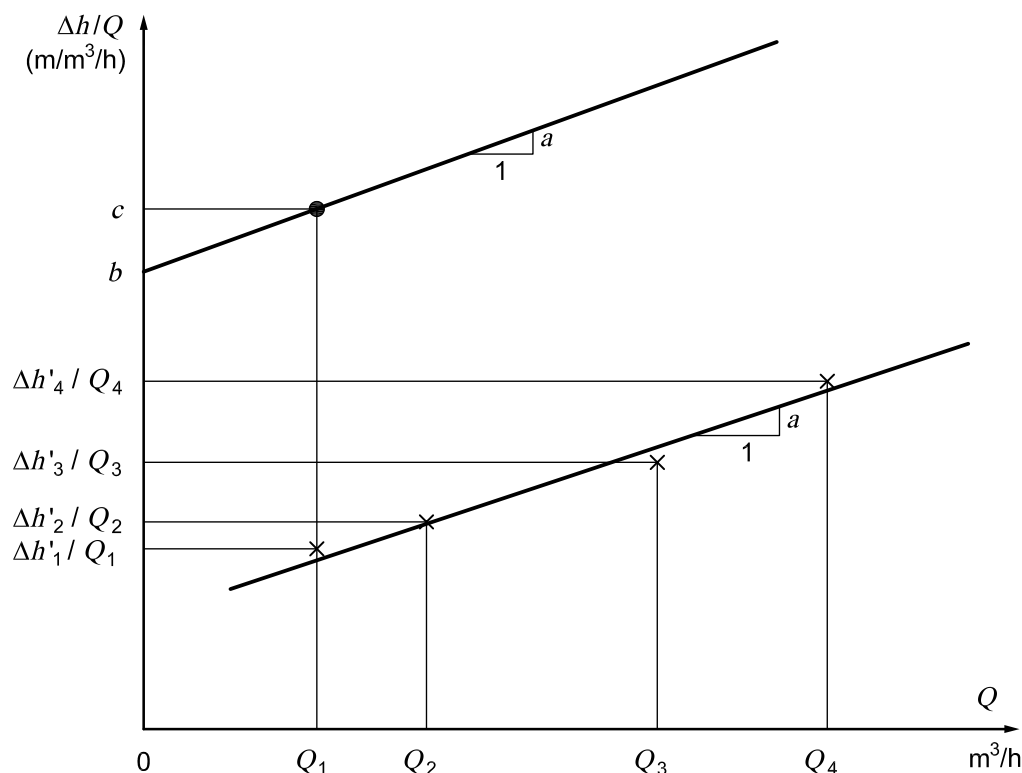

**Key**

1 well axis

**Figure B.2 — Determination of coefficients  $a$  and  $b$  of the characteristic drawdown curve in the well during the preliminary test**

**B.3.5 Determining the test pumping discharge rate  $Q_e$**

The test discharge rate is the solution of the equation of the characteristic well drawdown curve determined in B.1:

$$Q_e = [(b^2 + 4a\Delta h_f)^{0,5} - b]/2a \text{ and } Q_e \leq 1.10^{-2} \pi DL \quad (\text{B.7})$$

where  $\Delta h_f$  is the target drawdown for the end of the test.

For a well that has penetrated an aquifer whose unconfined groundwater surface at rest lies at a height  $e$  above the bottom of the well,  $\Delta h_f \leq e/3$ .

For a well in an aquifer with confined groundwater,  $\Delta h_f$  is the final drawdown that brings the water level in the well no lower than 0,5 m above the level of the top of the aquifer, such that in general  $\Delta h_f \leq e/3$ . The drawdown shall always leave water in the well to a height of at least 0,5 m above the upper part of the screen.

## **Annex C** (informative)

### **Interpretation of the pumping test results**

#### **C.1 Variable rate pumping tests**

Well characteristics can be deduced from variable rate tests according to B.2.

#### **C.2 Constant rate pumping tests — Steady-state analysis**

##### **C.2.1 General**

Steady-state is defined as the condition, in the later stages of a pumping test, when groundwater levels remain constant, or vary so slowly as to be effectively constant.

The interpretation methods presented in this section are based upon (among other things) the following basic assumptions:

- homogenous and isotropic aquifer of constant thickness and infinite horizontal extent;
- horizontal groundwater level prior to the start of pumping;
- constant discharge rate;
- a test well that fully penetrates the aquifer.

In cases of significant difference to the above-mentioned simplifying conditions, corrections should be made according to the literature.

##### **C.2.2 Confined aquifer**

###### **C.2.2.1 General**

The hydrogeological conditions of a confined aquifer are shown in Figure C.1.



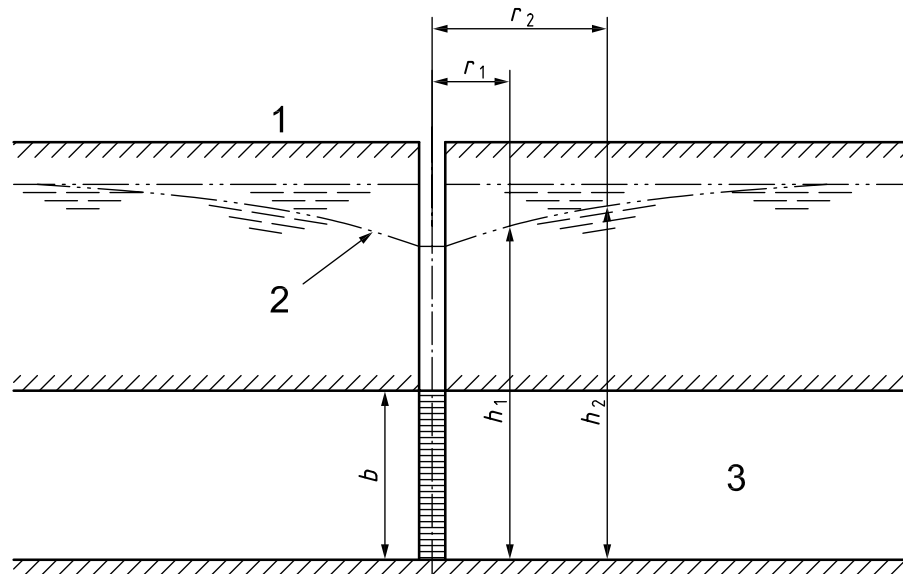

**Key**

- 1 static water level
- 2 equilibrium water level
- 3 confined aquifer

**Figure C.1 — Confined aquifer**

**C.2.2.2 Method according to Dupuit/Thiem: Mathematical solution**

In the case of an aquifer confined at the top and bottom (Figure C.1), transmissivity can be computed according to the solution of Thiem.

$$T = \frac{Q}{2\pi(h_2 - h_1)} \ln\left(\frac{r_2}{r_1}\right) \quad (\text{C.1})$$

where

- $T$  is aquifer transmissivity, in  $\text{m}^2/\text{s}$ ;
- $Q$  is pumping rate, in  $\text{m}^3/\text{s}$ ;
- $h_1$  is piezometric head at distance  $r_1$  from the pumping well, in m;
- $h_2$  is piezometric head at distance  $r_2$  from the pumping well, in m.

The permeability coefficient  $k$  (in m/s) can be determined from  $k = T/d$  where  $d$  is the thickness of the aquifer (in m).

**C.2.2.3 Method according to Dupuit/Thiem: Graphical solution**

A graphical solution can be applied, as follows:

- drawdown in each observation well is to be plotted against its distance from the test well on semi-logarithmic axes as shown in Figure C.2.

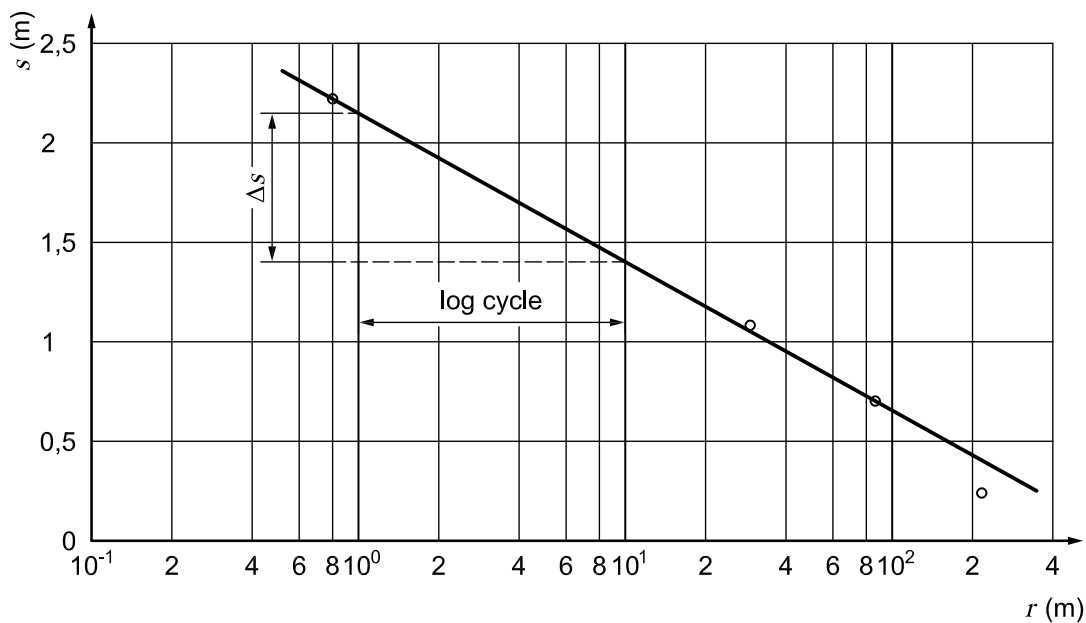

Figure C.2 — Graphical solution according to Dupuit/Thiem

- $\Delta s$  is the change in drawdown per log cycle of distance from the test well, is determined from the graphical plot and is substituted in Equation (C.2) below:

$$T = \frac{2,30 Q}{2\pi\Delta s} \quad (\text{C.2})$$

where

$T$  is aquifer transmissivity, in  $\text{m}^2/\text{s}$ ;

$Q$  is pumping rate, in  $\text{m}^3/\text{s}$ ;

$\Delta s$  is the change in drawdown per log cycle of time, in m.

### C.2.3 Unconfined aquifer

For the case of an unconfined aquifer underlain by a horizontal aquiclude (Figure C.3), the modified Dupuit/Thiem equation can be used.

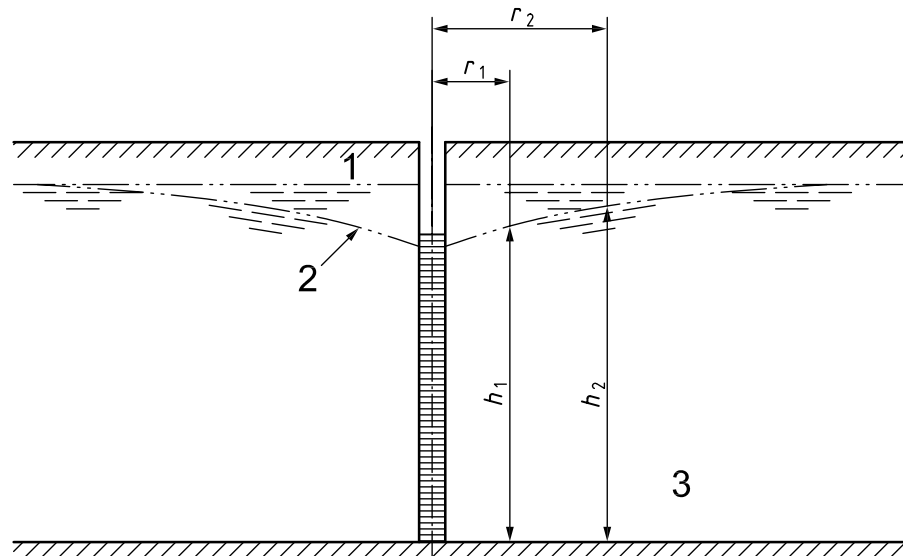

**Key**

- 1 static water level
- 2 equilibrium water level
- 3 unconfined aquifer

**Figure C.3 — Unconfined aquifer**

$$k = \frac{Q}{2\pi(h_2^2 - h_1^2)} \ln\left(\frac{r_2}{r_1}\right) \quad (\text{C.3})$$

where

- $k$  is permeability coefficient, in m/s;
- $Q$  is flow rate in m<sup>3</sup>/s;
- $h_1$  is piezometric head at distance  $r_1$  from the pumping well, in m;
- $h_2$  is piezometric head at distance  $r_2$  from the pumping well, in m.

The graphical solution presented in C.2.2.1 can also be used for the unconfined aquifer, with the reservation that the Dupuit formula fails to give an accurate description of the drawdown curve near the well, where the horizontal flow conditions (that are an implicit assumption of the method) are not present.

### C.3 Constant rate pumping tests — Transient-state analysis

#### C.3.1 General

Transient-state is defined as the condition, in the early stages of the pumping phase of a test, where groundwater levels are falling. The rate of fall will change as pumping continues. Alternatively, during the post-pumping phase, the transient-state is when water levels are rising.

#### C.3.2 Method according to Theis

The Theis method can be used in confined aquifers where the test well and piezometers fully penetrate the aquifer under test. In addition to the assumptions quoted for steady-state methods, the Theis method assumes that water is released from storage in the aquifer instantaneously with drawdown in water level. This condition is typically satisfied in relatively free-draining soils such as sands or gravels.

By Theis<sup>[4]</sup>, the drawdown  $s$  in a piezometer is given by:

$$s = \frac{Q}{4\pi T} W(u) \quad (C.4)$$

where

$$u = \frac{r^2 S}{4Tt} \quad (C.5)$$

and where

- $s$  is the drawdown, in m;
- $Q$  is the constant flow rate from the test well, in m<sup>3</sup>/s;
- $t$  is the elapsed time of pumping, in s;
- $T$  is the transmissivity, in m<sup>2</sup>/s;
- $W(u)$  is the Theis well function (tabulated values are given in [4]);
- $r$  is the radial distance from the test well to the piezometer, in m;
- $S$  is the storage coefficient.

The permeability coefficient  $k$  (in m/s) can be determined from  $k = T/d$  where  $d$  is the thickness of the aquifer (in m).

The analysis requires that the values of  $s$  for the piezometer be plotted against  $r^2/t$  on logarithmic axes (Figure C.4). A type curve of  $W(u)$  from published sources (such as [x]) is then plotted on logarithmic axes of the same scale as the piezometer data. The type curve and the piezometer data are then superimposed, and adjusted relative to each other until most of the piezometer data overlies and match with the type curve.

An arbitrary match point is selected from within the area where the piezometer data overlies the type curve, and the co-ordinates of the match point are recorded. The values of  $W(u)$ ,  $u$ ,  $s$  and  $r^2/t$  so determined are substituted into the equations above. This allows  $T$ ,  $S$  and  $k$  to be determined.

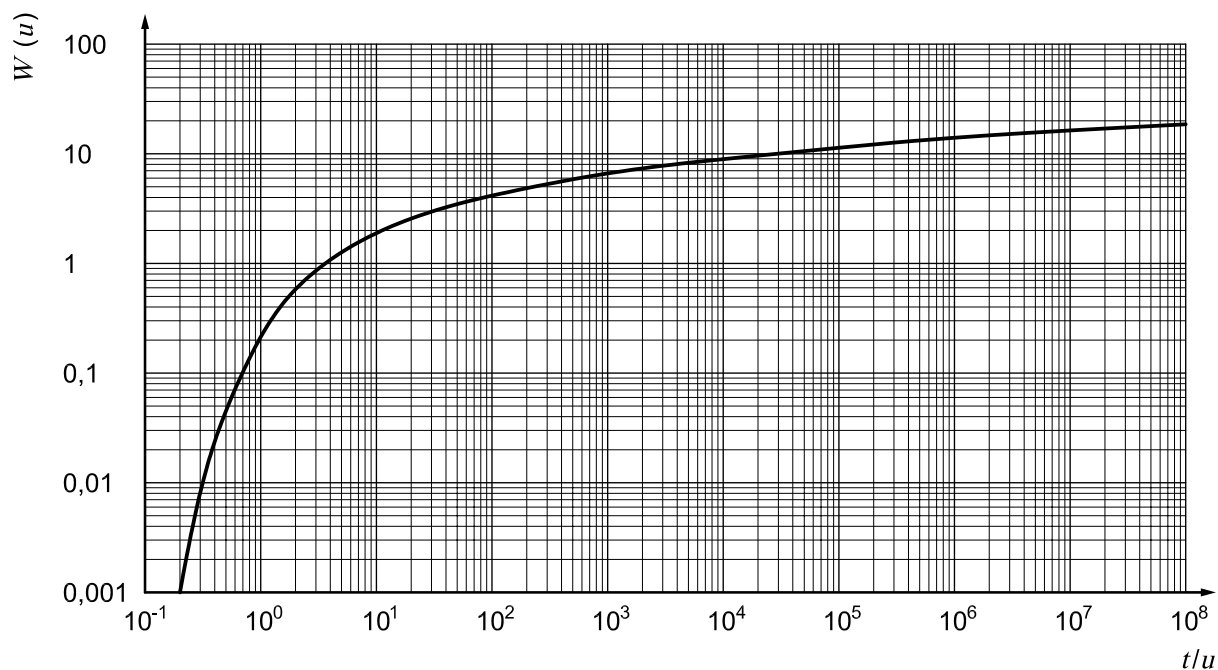

Figure C.4 — Theis type curve

### C.3.3 Method according to Cooper and Jacob

The Cooper-Jacob method [x] is a straight line method, based on a simplification of the Theis method. The Cooper-Jacob method is based on the same assumptions as Theis, but in addition there is a requirement that  $u$  is small, specifically:

$$u = \frac{r^2 S}{4Tt} \leq 0,01 \quad (\text{C.6})$$

This condition is typically satisfied in confined aquifers when pumping has continued for more than a few hours.

The Cooper-Jacob method can be applied to both the change in drawdown with elapsed time since pumping began, or to change in drawdown with distance from the test well.

Analysis of time drawdown data requires that drawdown data for each piezometer be plotted against time on semi-logarithmic axes (Figure C.5). The main part of the data should plot as a straight line. A value for  $\Delta s$ , the change in drawdown per log cycle of time, is obtained from the straight line portion of the data. A value for  $t_0$ , the zero drawdown intercept, is obtained by extrapolating the straight line back to the zero drawdown axis. Values are then substituted into the following equations:

$$k = \frac{2,3Q}{4\pi\Delta sD} \quad (\text{C.7})$$

$$S = \frac{2,25 kdt_0}{r^2} \quad (\text{C.8})$$

where

- $\Delta s$  is the change in drawdown per log cycle of time, in m;
- $Q$  is the constant flow rate from the test well, in m<sup>3</sup>/s;
- $t_0$  is the extrapolated time at zero drawdown, in s;
- $k$  is the permeability coefficient, in m/s;
- $d$  is the thickness of the aquifer, in m;
- $r$  is the radial distance from the test well to the piezometer, in m;
- $S$  is the storage coefficient.

NOTE Although time is given in seconds in the above equations, it is convenient to plot  $t$  in minutes on the drawdown-time semi-logarithmic graph (see Figure C.5).

Analysis of distance drawdown data requires that drawdown at each piezometer at the same particular time  $t$  be plotted against radial distance from the test well  $r$  on semi-logarithmic axes (Figure C.5). The data should plot as a straight line. A value for  $\Delta s$ , the change in drawdown per log cycle of distance, is obtained from the straight line. A value for  $r_0$ , the zero drawdown intercept, is obtained by extrapolating the straight line to the zero drawdown axis. Values are then substituted into the following equations:

$$k = \frac{2,3 Q}{2\pi\Delta s d} \quad (\text{C.9})$$

$$S = \frac{2,25 \text{ } kdt}{r_0^2} \tag{C.10}$$

where

- $t$  is the elapsed time of pumping, in s;
- $\Delta s$  is the change in drawdown per log cycle of distance, in m;
- $r_0$  is the extrapolated radius from the test well at zero drawdown, in m.

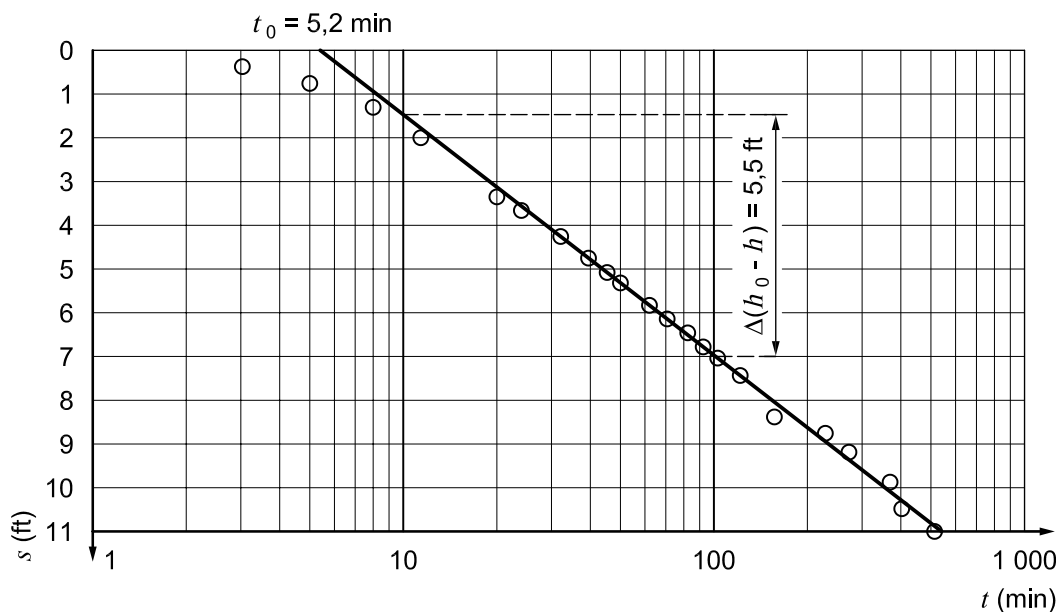

Figure C.5 — Cooper-Jacob straight line analysis

### C.3.4 More complex methods

The methods of Theis and Cooper-Jacob presented in previous clauses assume that the aquifer is confined and the wells fully penetrate the aquifer. These methods can sometimes be used when these conditions are not fully satisfied. For example, these methods can give approximate results in unconfined aquifers, provided the drawdown is only a small proportion of the original aquifer thickness. Similarly, these methods can be used for partially penetrating wells, provided that the wells penetrate a significant proportion of the aquifer thickness.

More complex methods of analysis are required for unconfined aquifers with significant drawdowns, for wells with only limited penetration into the aquifer, for aquifers where water is released slowly from storage (delayed yield) or for where water can pass into the aquifer from adjoining low permeability aquitards (leaky aquifers). Methods of analysis for these conditions can be found in the Bibliography.

## Bibliography

- [1] EN 1997-1, *Eurocode 7: Geotechnical design — Part 1: General rules*
- [2] EN 1997-2, *Eurocode 7: Geotechnical design — Part 2: Ground investigation and testing*
- [3] KRUSEMAN, G.P. and DE RIDDER, N.A. (1990). *Analysis and Evaluation of Pumping Test Data*. International Institute for Land Reclamation and Improvement, Publication 47, 2<sup>nd</sup> edition. Wageningen, The Netherlands
- [4] THEIS, C.V. (1935). *The relation between the lowering of the piezometric surface and the rate and duration of discharge of a well using groundwater storage*. Transactions of the American Geophysical Union, 16, pp. 519-524
- [5] COOPER, H.H. and JACOB, C.E. (1946). *A generalized graphical method for evaluating formation constants and summarizing wellfield history*. Transactions of the American Geophysical Union, 27, pp. 526-534
- [6] DRISCOLL, F.G. (1986). *Groundwater and Wells*. Johnson Division, St Paul, Minnesota
- [7] GENETIER, B. (1992), *La pratique des pompages d'essai en hydrogéologie*. Manuels et méthodes n° 9, Editions BRGM, Orléans, France







# British Standards Institution (BSI)

BSI is the national body responsible for preparing British Standards and other standards-related publications, information and services.

BSI is incorporated by Royal Charter. British Standards and other standardization products are published by BSI Standards Limited.

## About us

We bring together business, industry, government, consumers, innovators and others to shape their combined experience and expertise into standards-based solutions.

The knowledge embodied in our standards has been carefully assembled in a dependable format and refined through our open consultation process. Organizations of all sizes and across all sectors choose standards to help them achieve their goals.

## Information on standards

We can provide you with the knowledge that your organization needs to succeed. Find out more about British Standards by visiting our website at [bsigroup.com/standards](http://bsigroup.com/standards) or contacting our Customer Services team or Knowledge Centre.

## Buying standards

You can buy and download PDF versions of BSI publications, including British and adopted European and international standards, through our website at [bsigroup.com/shop](http://bsigroup.com/shop), where hard copies can also be purchased.

If you need international and foreign standards from other Standards Development Organizations, hard copies can be ordered from our Customer Services team.

## Subscriptions

Our range of subscription services are designed to make using standards easier for you. For further information on our subscription products go to [bsigroup.com/subscriptions](http://bsigroup.com/subscriptions).

With **British Standards Online (BSOL)** you'll have instant access to over 55,000 British and adopted European and international standards from your desktop. It's available 24/7 and is refreshed daily so you'll always be up to date.

You can keep in touch with standards developments and receive substantial discounts on the purchase price of standards, both in single copy and subscription format, by becoming a **BSI Subscribing Member**.

**PLUS** is an updating service exclusive to BSI Subscribing Members. You will automatically receive the latest hard copy of your standards when they're revised or replaced.

To find out more about becoming a BSI Subscribing Member and the benefits of membership, please visit [bsigroup.com/shop](http://bsigroup.com/shop).

With a **Multi-User Network Licence (MUNL)** you are able to host standards publications on your intranet. Licences can cover as few or as many users as you wish. With updates supplied as soon as they're available, you can be sure your documentation is current. For further information, email [bsmusales@bsigroup.com](mailto:bsmusales@bsigroup.com).

## BSI Group Headquarters

389 Chiswick High Road London W4 4AL UK

## Revisions

Our British Standards and other publications are updated by amendment or revision.

We continually improve the quality of our products and services to benefit your business. If you find an inaccuracy or ambiguity within a British Standard or other BSI publication please inform the Knowledge Centre.

## Copyright

All the data, software and documentation set out in all British Standards and other BSI publications are the property of and copyrighted by BSI, or some person or entity that owns copyright in the information used (such as the international standardization bodies) and has formally licensed such information to BSI for commercial publication and use. Except as permitted under the Copyright, Designs and Patents Act 1988 no extract may be reproduced, stored in a retrieval system or transmitted in any form or by any means – electronic, photocopying, recording or otherwise – without prior written permission from BSI. Details and advice can be obtained from the Copyright & Licensing Department.

## Useful Contacts:

### Customer Services

**Tel:** +44 845 086 9001

**Email (orders):** [orders@bsigroup.com](mailto:orders@bsigroup.com)

**Email (enquiries):** [cservices@bsigroup.com](mailto:cservices@bsigroup.com)

### Subscriptions

**Tel:** +44 845 086 9001

**Email:** [subscriptions@bsigroup.com](mailto:subscriptions@bsigroup.com)

### Knowledge Centre

**Tel:** +44 20 8996 7004

**Email:** [knowledgecentre@bsigroup.com](mailto:knowledgecentre@bsigroup.com)

### Copyright & Licensing

**Tel:** +44 20 8996 7070

**Email:** [copyright@bsigroup.com](mailto:copyright@bsigroup.com)



...making excellence a habit.™