

Dentistry — Manual toothbrushes — Resistance of tufted portion to deflection

The European Standard EN ISO 22254:2005 has the status of a
British Standard

ICS 97.170

National foreword

This British Standard is the official English language version of EN ISO 22254:2005. It is identical with ISO 22254:2005. Together with BS EN ISO 20126:2005, it supersedes BS 5757:1989 which is withdrawn.

The UK participation in its preparation was entrusted by Technical Committee CH/106, Dentistry, to Subcommittee CH/106/7, Oral hygiene products, which has the responsibility to:

- aid enquirers to understand the text;
- present to the responsible international/European committee any enquiries on the interpretation, or proposals for change, and keep UK interests informed;
- monitor related international and European developments and promulgate them in the UK.

A list of organizations represented on this subcommittee can be obtained on request to its secretary.

Cross-references

The British Standards which implement international or European publications referred to in this document may be found in the *BSI Catalogue* under the section entitled “International Standards Correspondence Index”, or by using the “Search” facility of the *BSI Electronic Catalogue* or of British Standards Online.

This publication does not purport to include all the necessary provisions of a contract. Users are responsible for its correct application.

Compliance with a British Standard does not of itself confer immunity from legal obligations.

Summary of pages

This document comprises a front cover, an inside front cover, the EN ISO title page, the EN ISO foreword page, the ISO title page, pages ii to iv, pages 1 to 7 and a back cover.

The BSI copyright notice displayed in this document indicates when the document was last issued.

Amendments issued since publication

Amd. No.	Date	Comments

English Version

Dentistry - Manual toothbrushes - Resistance of tufted portion to deflection (ISO 22254:2005)

Art dentaire - Brosses à dents manuelles - Résistance à la déflexion de la surface garnie (ISO 22254:2005)

Zahnheilkunde - Handzahnbürsten - Biegefestigkeit der Besteckungsfläche (ISO 22254:2005)

This European Standard was approved by CEN on 8 August 2005.

CEN members are bound to comply with the CEN/CENELEC Internal Regulations which stipulate the conditions for giving this European Standard the status of a national standard without any alteration. Up-to-date lists and bibliographical references concerning such national standards may be obtained on application to the Central Secretariat or to any CEN member.

This European Standard exists in three official versions (English, French, German). A version in any other language made by translation under the responsibility of a CEN member into its own language and notified to the Central Secretariat has the same status as the official versions.

CEN members are the national standards bodies of Austria, Belgium, Cyprus, Czech Republic, Denmark, Estonia, Finland, France, Germany, Greece, Hungary, Iceland, Ireland, Italy, Latvia, Lithuania, Luxembourg, Malta, Netherlands, Norway, Poland, Portugal, Slovakia, Slovenia, Spain, Sweden, Switzerland and United Kingdom.



EUROPEAN COMMITTEE FOR STANDARDIZATION
COMITÉ EUROPÉEN DE NORMALISATION
EUROPÄISCHES KOMITEE FÜR NORMUNG

Management Centre: rue de Stassart, 36 B-1050 Brussels

EN ISO 22254:2005

Foreword

This document (EN ISO 22254:2005) has been prepared by Technical Committee ISO/TC 106 "Dentistry" in collaboration with Technical Committee CEN/TC 55 "Dentistry", the secretariat of which is held by DIN.

This European Standard shall be given the status of a national standard, either by publication of an identical text or by endorsement, at the latest by February 2006, and conflicting national standards shall be withdrawn at the latest by February 2006.

This document supersedes EN 28627:1990.

According to the CEN/CENELEC Internal Regulations, the national standards organizations of the following countries are bound to implement this European Standard: Austria, Belgium, Cyprus, Czech Republic, Denmark, Estonia, Finland, France, Germany, Greece, Hungary, Iceland, Ireland, Italy, Latvia, Lithuania, Luxembourg, Malta, Netherlands, Norway, Poland, Portugal, Slovakia, Slovenia, Spain, Sweden, Switzerland and United Kingdom.

Endorsement notice

The text of ISO 22254:2005 has been approved by CEN as EN ISO 22254:2005 without any modifications.

INTERNATIONAL
STANDARD

ISO
22254

First edition
2005-08-15

**Dentistry — Manual toothbrushes —
Resistance of tufted portion to deflection**

*Art dentaire — Brosses à dents manuelles — Résistance à la déflexion
de la surface garnie*



Reference number
ISO 22254:2005(E)

Foreword

ISO (the International Organization for Standardization) is a worldwide federation of national standards bodies (ISO member bodies). The work of preparing International Standards is normally carried out through ISO technical committees. Each member body interested in a subject for which a technical committee has been established has the right to be represented on that committee. International organizations, governmental and non-governmental, in liaison with ISO, also take part in the work. ISO collaborates closely with the International Electrotechnical Commission (IEC) on all matters of electrotechnical standardization.

International Standards are drafted in accordance with the rules given in the ISO/IEC Directives, Part 2.

The main task of technical committees is to prepare International Standards. Draft International Standards adopted by the technical committees are circulated to the member bodies for voting. Publication as an International Standard requires approval by at least 75 % of the member bodies casting a vote.

Attention is drawn to the possibility that some of the elements of this document may be the subject of patent rights. ISO shall not be held responsible for identifying any or all such patent rights.

ISO 22254 was prepared by Technical Committee ISO/TC 106, *Dentistry*, Subcommittee SC 7, *Oral care products*.

This first edition cancels and replaces ISO 8627:1987.

Introduction

The stiffness of the tufted area of a manual toothbrush has been of great concern for both consumers and manufacturers. This International Standard provides a test method for determining the resistance of the tufted portion to deflection, which could be used to derive a stiffness as described in Annex A. However, this International Standard does not cover stiffness of manual toothbrushes and its classification. For stiffness determination, the measurement of the tufted area is required, but the result of the measurement varies over a wide range depending on the method of the measurement and the shape of the tuft holes. Therefore, the tufted area and stiffness determinations are described in Annex A. Since the perception of stiffness differs amongst different countries, stiffness may be classified differently in each country.

Dentistry — Manual toothbrushes — Resistance of tufted portion to deflection

1 Scope

This International Standard specifies a test method for determining the resistance of the tufted portion of manual toothbrushes to deflection. This International Standard is applicable to toothbrushes having a conventional, flat trim design and may not be applicable to toothbrushes with other designs. The results obtained with this International Standard may not correspond to consumer perceptions of the stiffness of toothbrush filaments.

2 Normative references

The following referenced documents are indispensable for the application of this document. For dated references, only the edition cited applies. For undated references, the latest edition of the referenced document (including any amendments) applies.

ISO 1942 (all parts), *Dentistry — Vocabulary*

ISO 3696:1987, *Water for analytical laboratory use — Specification and test methods*

3 Terms and definitions

For the purposes of this document, the terms and definitions given in ISO 1942-1 to ISO 1942-5 and the following apply.

3.1

manual toothbrush

hand-powered device primarily for cleaning surfaces of teeth, the working end of which carries filaments

3.2

brush head

working end of a toothbrush to which the filaments are attached

3.3

filament

single strand within the brush head

3.4

tuft

group of filaments gathered together and attached to the brush head

3.5

tuft hole surface

surface of the tuft holes, which can be convex, triangular or plane and which is limited by a peripheral tangent line to the outer tuft holes

3.6

tuft hole plane

plane between the base of the tufts (where they meet the face of the brush) at the top of the brush head and the base of the tufts at the bottom of the brush head

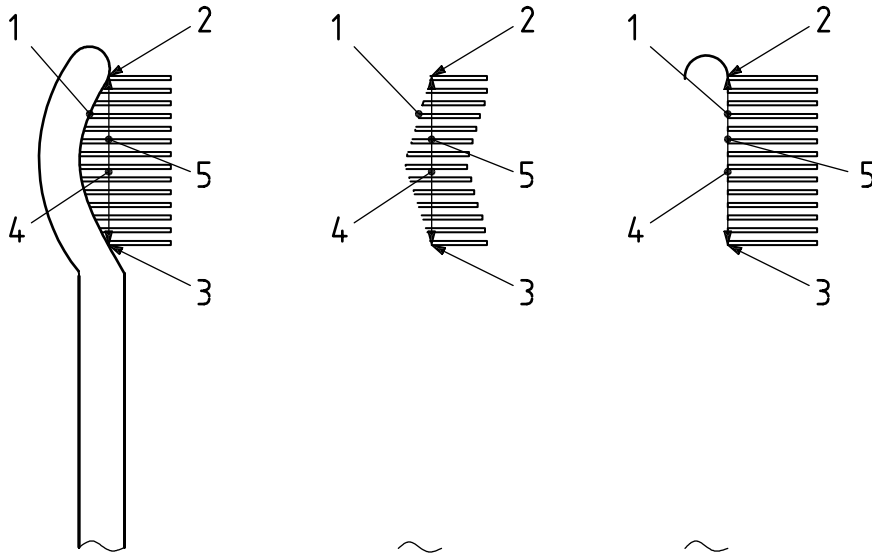

a) Side view of brush head

Key

- 1 tuft hole surface
- 2 top of brush head
- 3 bottom of brush head
- 4 tuft hole plane
- 5 tufted area

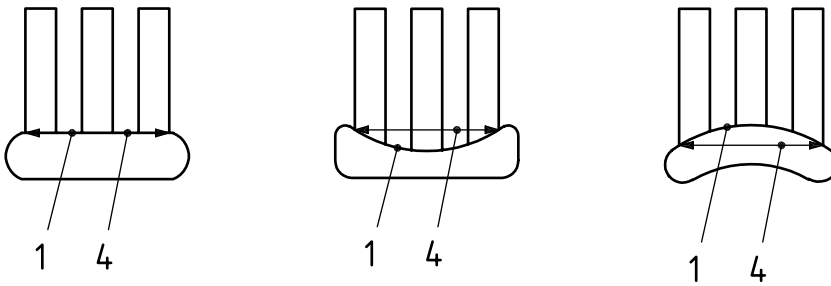

b) Top view of brush head

Key

- 1 tuft hole surface
- 4 tuft hole plane

Figure 1 — Tuft hole plane

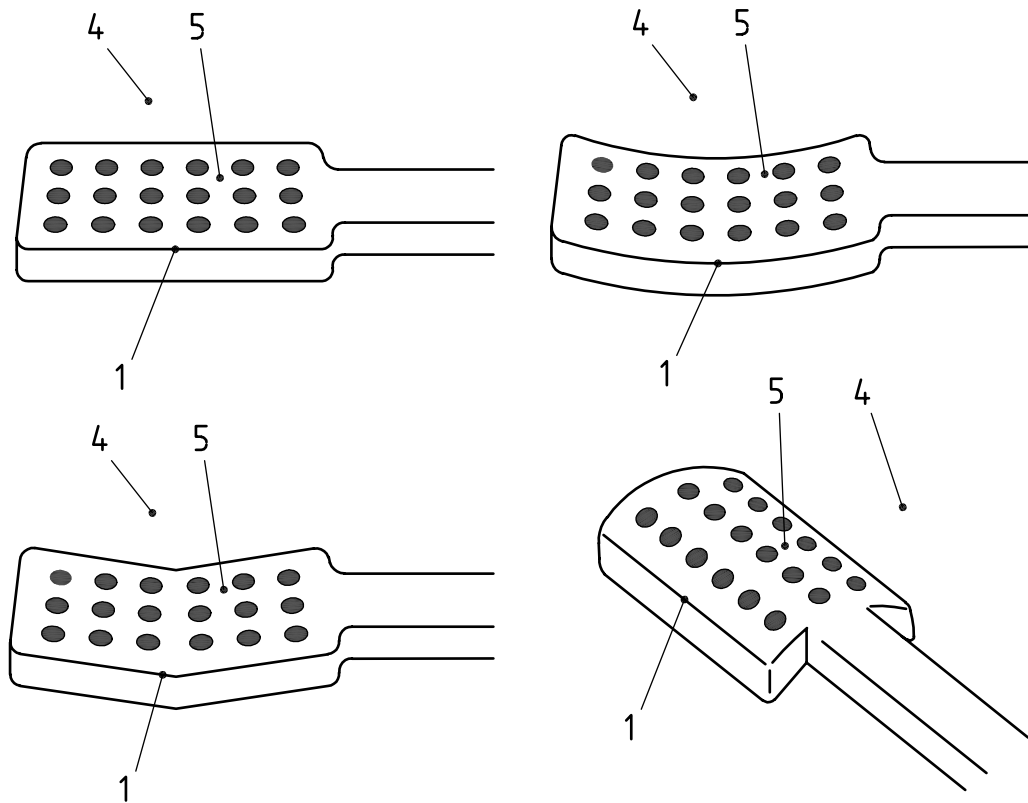

c) After removal of tufts

Key

- 1 tuft hole surface
- 4 tuft hole plane
- 5 tufted area

Figure 1 (continued)

3.7

tufted area

linear projection of the tuft hole surface on to the tuft hole plane

NOTE An alternative definition is: area surrounded by a peripheral tangent line to the outer tufts where they meet the tuft hole plane.

3.8

brush neck

part of the toothbrush which joins the brush head to the handle

3.9

resistance to deflection

resisting force of the tufts to deflection under a force of 5 N, applied at right angles to the tuft hole plane

4 Sampling

The toothbrushes obtained for testing shall be as-manufactured and not modified in any way, except as specified for this International Standard.

Five brushes shall be tested.

The sampling method and the means of procurement are not covered by this International Standard and should be subject to agreement between the interested parties.

5.1 Apparatus

5.1.1 Test machine (see Figure 2), capable of measuring the resistance of the tufted portion to deflection, consisting of the following components:

5.1.1.1 Brushing table (see Figure 3), consisting of five rods ($3,2 \pm 0,1$) mm diameter, with a distance between the centres of the two rods of ($8,2 \pm 0,1$) mm, made of a hard metal such as stainless steel.

5.1.1.2 Vertical column, consisting of a gripping block for the brush head such that it does not flex and applies ($5 \pm 0,05$) N to the gripped brush.

5.1.1.3 Load cell, of force range from 0 to 20 N and accurate to 0,05 N, connected to one end of the brushing table.

5.1.1.4 Driving unit, which moves the table back and forth along the longitudinal axis at a rate between 10 mm/s and 50 mm/s (traverse distance: more than the length of a brush head).

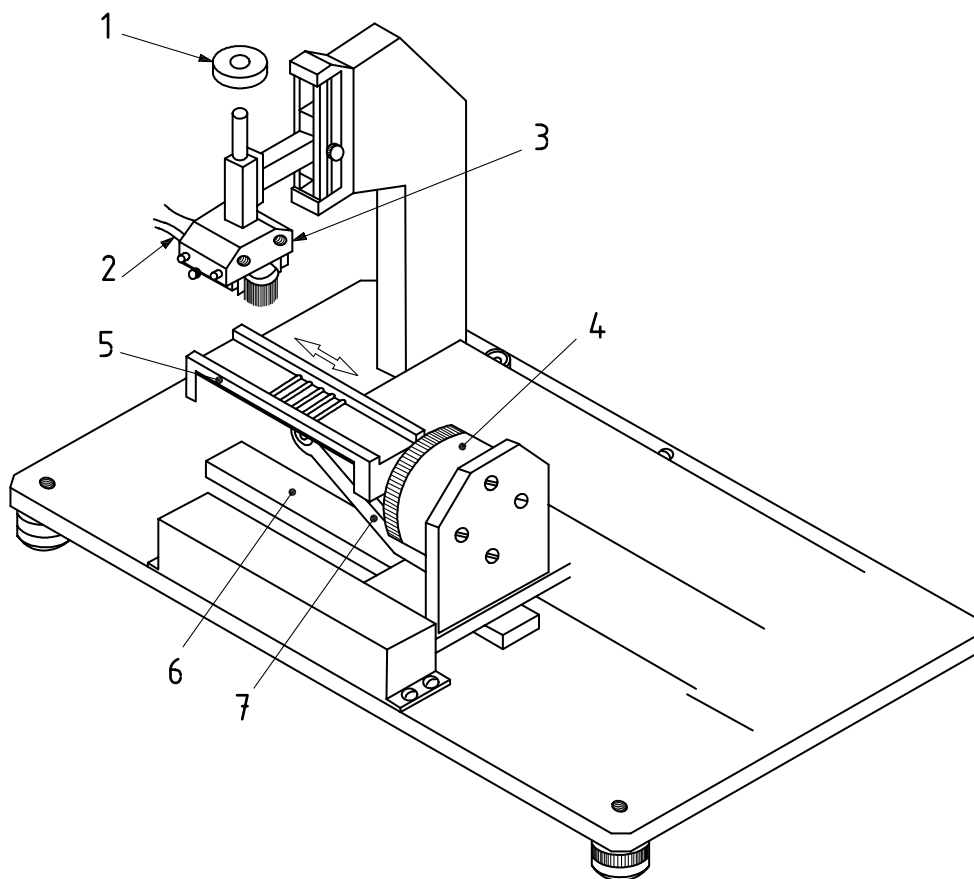

Key

- 1 mass to exert force
- 2 brush head
- 3 gripping block
- 4 load cell
- 5 brushing table
- 6 rail
- 7 support

Figure 2 — Test machine

Dimensions in millimetres

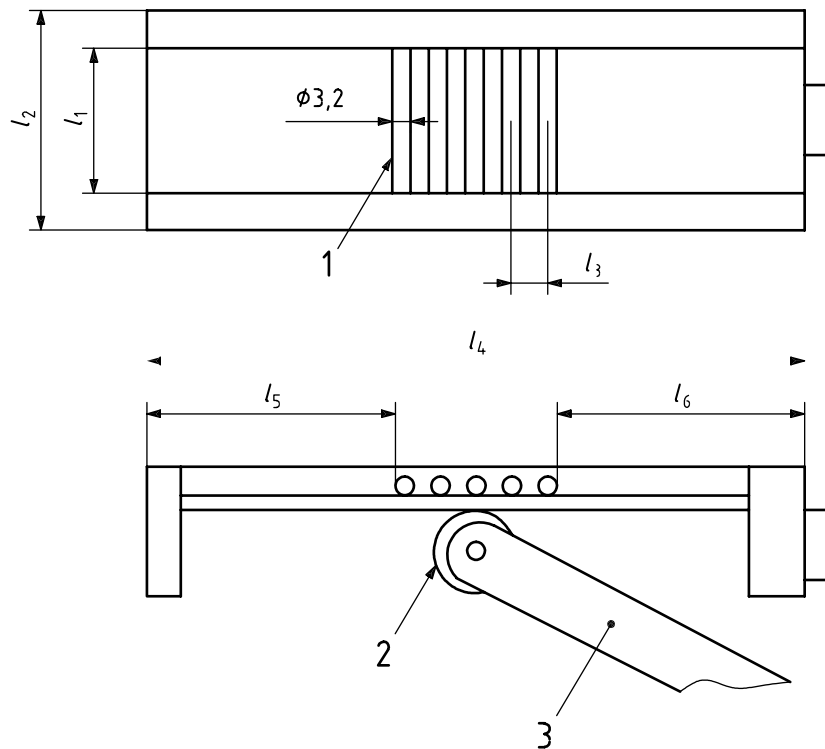

Key

- 1 rod
- 2 bearing
- 3 support

l_1	30 to 40	l_4	150 to 170
l_2	45 to 50	l_5	55 to 60
l_3	8,2	l_6	55 to 60

Figure 3 — Brushing table of test machine

5.2 Test conditions

All tests shall be conducted at $(23 \pm 5) ^\circ\text{C}$ unless otherwise specified.

5.3 Conditioning of toothbrushes

Cut off the brush head at the neck, discard the handle and weigh the brush head to the nearest 0,5 g. Immerse the brush head in water, in accordance with grade 3 of ISO 3696:1987, at $(37 \pm 2) ^\circ\text{C}$ for 90 s. After immersion, shake off excess water and fix the brush head in the gripping device.

5.4.1 Positioning of the brush head

Attach the gripping device [(3) in Figure 2] to the test machine (see Figure 2), such that the tuft hole plane is parallel to the brushing table [(5) in Figure 2]. Position the brush head in line with the brushing table, avoiding contact with the rods [(1) in Figure 3]. Adjust the force on the brush head [(2) in Figure 2] to $(5 \pm 0,05)$ N, taking into account the mass of a brush head weighed in 5.3. Lower the brush head assembly on to the flat surface of the brushing table, until the load is completely transferred to the table.

NOTE A convenient method of positioning is to make use of a positioning block, e.g. made of a material such as a polyvinylsiloxane impression material (putty type) or epoxy resin, which fits the gripping block.

5.4.2 Measurement of resistance to deflection

Within $(3 \pm 0,25)$ min after removal of the brush head from the water, start the sliding movement of the brushing table at a sliding velocity between 10 mm/s and 50 mm/s. At the end of five cycles, record the maximum force in newtons given by the load cell [(4) in Figure 2] for each of the two directions. Calculate the mean of the two recorded values as the resistance to deflection.

Repeat the procedure for the remaining four toothbrushes and calculate the overall mean resistance to deflection.

NOTE A cycle is the travel of the brushing table from its original position to the limit of travel and back to the original position.

5.4.3 Test report

Report the resistance to deflection of each of the five toothbrushes tested, the mean resistance to deflection, the standard deviation and name of toothbrush.

Annex A (informative)

Determination of stiffness of the tufted portion of toothbrush

The stiffness of the tufted portion of a toothbrush is determined by the following procedure after the measurement of the resistance to deflection.

Remove all tufts from the five tested brush heads and take a photograph or draw a tracing of the tuft hole plane for each of the five heads under three times to ten times magnification. Measure the tufted area either on the photograph or the tracing to within $\pm 0,1 \text{ cm}^2$ using a planimeter and calculate the tufted area, A , of the brush head. Calculate the stiffness, in newtons per square centimetre (N/cm^2) for each toothbrush, using the following formula:

$$S_{\text{tf}} = F/A$$

where

S_{tf} is the stiffness;

F is the resistance to deflection, in newtons;

A is the tufted area, in square centimetres.

Report the stiffness of each of the five toothbrushes tested and the mean stiffness.

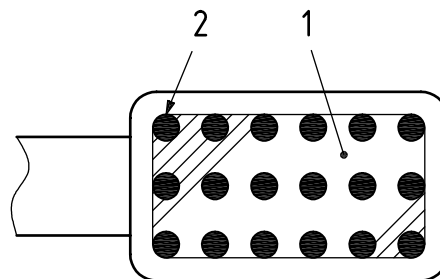

Key

- 1 tufted area (shaded)
- 2 tufted hole (black circles)

Figure A.1 — Tufted portion of toothbrush

BSI — British Standards Institution

BSI is the independent national body responsible for preparing British Standards. It presents the UK view on standards in Europe and at the international level. It is incorporated by Royal Charter.

Revisions

British Standards are updated by amendment or revision. Users of British Standards should make sure that they possess the latest amendments or editions.

It is the constant aim of BSI to improve the quality of our products and services. We would be grateful if anyone finding an inaccuracy or ambiguity while using this British Standard would inform the Secretary of the technical committee responsible, the identity of which can be found on the inside front cover. Tel: +44 (0)20 8996 9000. Fax: +44 (0)20 8996 7400.

BSI offers members an individual updating service called PLUS which ensures that subscribers automatically receive the latest editions of standards.

Buying standards

Orders for all BSI, international and foreign standards publications should be addressed to Customer Services. Tel: +44 (0)20 8996 9001. Fax: +44 (0)20 8996 7001. Email: orders@bsi-global.com. Standards are also available from the BSI website at <http://www.bsi-global.com>.

In response to orders for international standards, it is BSI policy to supply the BSI implementation of those that have been published as British Standards, unless otherwise requested.

Information on standards

BSI provides a wide range of information on national, European and international standards through its Library and its Technical Help to Exporters Service. Various BSI electronic information services are also available which give details on all its products and services. Contact the Information Centre. Tel: +44 (0)20 8996 7111. Fax: +44 (0)20 8996 7048. Email: info@bsi-global.com.

Subscribing members of BSI are kept up to date with standards developments and receive substantial discounts on the purchase price of standards. For details of these and other benefits contact Membership Administration. Tel: +44 (0)20 8996 7002. Fax: +44 (0)20 8996 7001. Email: membership@bsi-global.com.

Information regarding online access to British Standards via British Standards Online can be found at <http://www.bsi-global.com/bsonline>.

Further information about BSI is available on the BSI website at <http://www.bsi-global.com>.

Copyright

Copyright subsists in all BSI publications. BSI also holds the copyright, in the UK, of the publications of the international standardization bodies. Except as permitted under the Copyright, Designs and Patents Act 1988 no extract may be reproduced, stored in a retrieval system or transmitted in any form or by any means – electronic, photocopying, recording or otherwise – without prior written permission from BSI.

This does not preclude the free use, in the course of implementing the standard, of necessary details such as symbols, and size, type or grade designations. If these details are to be used for any other purpose than implementation then the prior written permission of BSI must be obtained.

Details and advice can be obtained from the Copyright & Licensing Manager. Tel: +44 (0)20 8996 7070. Fax: +44 (0)20 8996 7553. Email: copyright@bsi-global.com.