

# Plastics — Determination of resistance to environmental stress cracking (ESC) —

## Part 3: Bent strip method

The European Standard EN ISO 22088-3:2006 has the status of a British Standard

ICS 83.080.01

## National foreword

This British Standard was published by BSI. It is the UK implementation of EN ISO 22088-3:2006. It supersedes BS EN ISO 4599:1997 which is withdrawn.

The UK participation in its preparation was entrusted to Technical Committee PRI/21, Testing of plastics.

A list of organizations represented on PRI/21 can be obtained on request to its secretary.

This publication does not purport to include all the necessary provisions of a contract. Users are responsible for its correct application.

**Compliance with a British Standard cannot confer immunity from legal obligations.**

This British Standard was published under the authority of the Standards Policy and Strategy Committee on 29 September 2006

© BSI 2006

ISBN 0 580 48768 7

### Amendments issued since publication

Amd. No.	Date	Comments

English Version

Plastics - Determination of resistance to environmental stress  
cracking (ESC) - Part 3: Bent strip method (ISO 22088-3:2006)

Plastiques - Détermination de la fissuration sous contrainte  
dans un environnement donné (ESC) - Partie 3: Méthode  
de l'éprouvette courbée (ISO 22088-3:2006)

Kunststoffe - Bestimmung der Beständigkeit gegen  
umgebungsbedingte Spannungsrissbildung (ESC) - Teil 3:  
Biegestreifenverfahren (ISO 22088-3:2006)

This European Standard was approved by CEN on 21 July 2006.

CEN members are bound to comply with the CEN/CENELEC Internal Regulations which stipulate the conditions for giving this European Standard the status of a national standard without any alteration. Up-to-date lists and bibliographical references concerning such national standards may be obtained on application to the Central Secretariat or to any CEN member.

This European Standard exists in three official versions (English, French, German). A version in any other language made by translation under the responsibility of a CEN member into its own language and notified to the Central Secretariat has the same status as the official versions.

CEN members are the national standards bodies of Austria, Belgium, Cyprus, Czech Republic, Denmark, Estonia, Finland, France, Germany, Greece, Hungary, Iceland, Ireland, Italy, Latvia, Lithuania, Luxembourg, Malta, Netherlands, Norway, Poland, Portugal, Romania, Slovakia, Slovenia, Spain, Sweden, Switzerland and United Kingdom.



EUROPEAN COMMITTEE FOR STANDARDIZATION  
COMITÉ EUROPÉEN DE NORMALISATION  
EUROPÄISCHES KOMITEE FÜR NORMUNG

Management Centre: rue de Stassart, 36 B-1050 Brussels

## **Foreword**

This document (EN ISO 22088-3:2006) has been prepared by Technical Committee ISO/TC 61 "Plastics" in collaboration with Technical Committee CEN/TC 249 "Plastics", the secretariat of which is held by IBN.

This European Standard shall be given the status of a national standard, either by publication of an identical text or by endorsement, at the latest by February 2007, and conflicting national standards shall be withdrawn at the latest by February 2007.

This document supersedes EN ISO 4599:1996.

According to the CEN/CENELEC Internal Regulations, the national standards organizations of the following countries are bound to implement this European Standard: Austria, Belgium, Cyprus, Czech Republic, Denmark, Estonia, Finland, France, Germany, Greece, Hungary, Iceland, Ireland, Italy, Latvia, Lithuania, Luxembourg, Malta, Netherlands, Norway, Poland, Portugal, Romania, Slovakia, Slovenia, Spain, Sweden, Switzerland and United Kingdom.

### **Endorsement notice**

The text of ISO 22088-3:2006 has been approved by CEN as EN ISO 22088-3:2006 without any modifications.

INTERNATIONAL  
STANDARD

ISO  
22088-3

First edition  
2006-08-15

---

---

**Plastics — Determination of resistance to  
environmental stress cracking (ESC) —**

**Part 3:  
Bent strip method**

*Plastiques — Détermination de la fissuration sous contrainte dans un  
environnement donné (ESC) —*

*Partie 3: Méthode de l'éprouvette courbée*



Reference number  
ISO 22088-3:2006(E)



## Contents

Page

Foreword.....	iv
1 Scope .....	1
2 Normative references .....	1
3 Terms and definitions.....	2
4 Principle.....	4
5 Apparatus .....	4
6 Test specimens .....	5
6.1 Form and dimensions.....	5
6.2 Preparation .....	5
6.3 Number .....	5
7 Conditioning and test conditions.....	5
7.1 Conditioning.....	5
7.2 Test temperature.....	5
7.3 Test medium.....	5
8 Procedure .....	5
8.1 Precautions .....	5
8.2 Mounting the test specimens .....	5
8.3 Contact with the test environment.....	6
8.4 Storage in contact with the test environment.....	6
8.5 Determination of the indicative property.....	7
9 Expression of results .....	7
9.1 Calculation.....	7
9.2 Graphical evaluation.....	7
10 Precision.....	8
11 Test report .....	9
Bibliography .....	10

## Foreword

ISO (the International Organization for Standardization) is a worldwide federation of national standards bodies (ISO member bodies). The work of preparing International Standards is normally carried out through ISO technical committees. Each member body interested in a subject for which a technical committee has been established has the right to be represented on that committee. International organizations, governmental and non-governmental, in liaison with ISO, also take part in the work. ISO collaborates closely with the International Electrotechnical Commission (IEC) on all matters of electrotechnical standardization.

International Standards are drafted in accordance with the rules given in the ISO/IEC Directives, Part 2.

The main task of technical committees is to prepare International Standards. Draft International Standards adopted by the technical committees are circulated to the member bodies for voting. Publication as an International Standard requires approval by at least 75 % of the member bodies casting a vote.

Attention is drawn to the possibility that some of the elements of this document may be the subject of patent rights. ISO shall not be held responsible for identifying any or all such patent rights.

ISO 22088-3 was prepared by Technical Committee ISO/TC 61, *Plastics*, Subcommittee SC 6, *Ageing, chemical and environmental resistance*.

It cancels and replaces ISO 4599:1986, which has been technically revised.

ISO 22088 consists of the following parts, under the general title *Plastics — Determination of resistance to environmental stress cracking (ESC)*:

- *Part 1: General guidance*
- *Part 2: Constant tensile load method* (replacement of ISO 6252:1992)
- *Part 3: Bent strip method* (replacement of ISO 4599:1986)
- *Part 4: Ball or pin impression method* (replacement of ISO 4600:1992)
- *Part 5: Constant tensile deformation method* (new test method)
- *Part 6: Slow strain rate method* (new test method)



# Plastics — Determination of resistance to environmental stress cracking (ESC) —

## Part 3: Bent strip method

### 1 Scope

This part of ISO 22088 specifies a method for the determination of the environmental stress cracking (ESC) resistance of thermoplastics when they are subjected to a fixed flexural strain in the presence of chemical agents.

ESC is indicated by the change of a suitably chosen indicative property of specimens that have been strained for a defined time in the environment. The method of test is suitable for determining the resistance of sheets and of flat test specimens, especially the sensitivity of localized surface regions of specimens, to ESC.

The bent strip method is suitable for the determination of ESC caused by gases and liquids as well as solids containing migrating substances (e.g. polymeric adhesives and materials containing plasticizers) in contact with a specific polymer.

Preferably, this method is used to determine the ESC resistance of rigid plastics that exhibit only moderate stress relaxation during the time of the test.

This is essentially a ranking test and is not intended to provide data to be used for design or performance prediction.

NOTE For a constant-strain test, refer to ISO 22088-5. For a constant-load test, refer to ISO 22088-2.

### 2 Normative references

The following referenced documents are indispensable for the application of this document. For dated references, only the edition cited applies. For undated references, the latest edition of the referenced document (including any amendments) applies.

ISO 178, *Plastics — Determination of flexural properties*

ISO 179-1, *Plastics — Determination of Charpy impact properties — Part 1: Non-instrumented impact test*

ISO 527-2, *Plastics — Determination of tensile properties — Part 2: Test conditions for moulding and extrusion plastics*

ISO 2818, *Plastics — Preparation of test specimens by machining*

ISO 22088-1:2006, *Plastics — Determination of resistance to environmental stress cracking (ESC) — Part 1: General guidance*

### 3 Terms and definitions

For the purposes of this document, the following terms and definitions apply.

#### 3.1 flexural strain

$\epsilon_x$   
nominal value of the strain in the tensile surface of a flat test specimen of thickness  $h$ , bent over the segment of a circle with radius  $r$ , calculated from the equation

$$\epsilon_x = \frac{h}{2r + h}$$

NOTE See Figure 1.

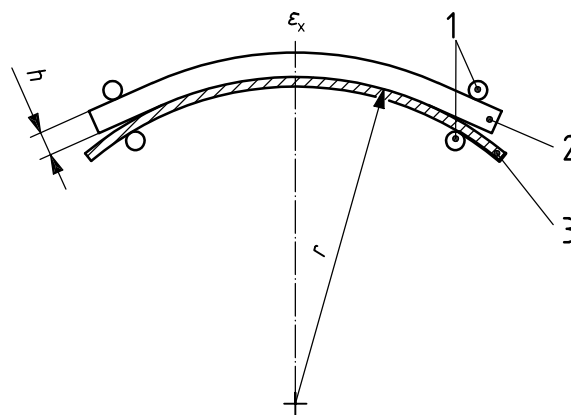

#### Key

- 1 clamps
- 2 test specimen: tensile surface in contact with test medium  
compressive surface in contact with form
- 3 form
- $h$  thickness of test specimen
- $r$  radius of form
- $\epsilon_x$  nominal strain in tensile surface

**Figure 1 — Test specimen with defined strain in the tensile surface**

#### 3.2 strain value

one of a series of strain levels applied to successive test specimens during exposure

#### 3.3 strain series

a number of strain values, including zero

NOTE 1 Normally, the results of the mechanical test on test specimens with zero applied strain are equivalent whether determined in air or in a chemical test medium. If the property measured after exposure to the test medium at zero strain is different from that after exposure in air at zero strain, embrittlement or softening by the test medium should be suspected. In some cases, relief of stresses imparted during specimen preparation such as by injection-moulding or machining can contribute to differences in results for stress cracking in air and another test medium.

NOTE 2 It is recommended that the test specimen for zero strain be clamped on to a flat form to prevent warping due to the effect of the test medium.

**3.4****failure strain** $\varepsilon_F$ 

lowest strain in the strain series at which failure is observed

**3.5****indicative property**

property observed to determine failure using a criterion such as those given in Table 1

**3.6****ESC index**

ratio of the value of failure strain determined in the test medium to that determined in the reference medium (usually air) for the same time of exposure

**Table 1 — Suggested indicative properties and failure criteria** (see Note 1)

Indicative property	International Standard	Failure criterion	Designation
State of surface (assessed by visual examination)	—	Cracks or crazes around the tensile surface edges	A1
State of surface (assessed by visual examination)	—	Cracks or crazes in the tensile surface	A2
State of surface (assessed by visual examination)	—	Any other observation, e.g. change in colour or appearance	A3
Tensile stress at break or tensile stress at yield	ISO 527-2	80 % of the value obtained on unstrained unexposed test specimens (see Note 2)	B1
Flexural stress at maximum load	ISO 178	80 % of the value obtained on unstrained unexposed test specimens (see Note 2)	B2
Percentage tensile strain at break or tensile strain at yield	ISO 527-2	50 % of the value obtained on unstrained unexposed test specimens (see Note 2)	B3
Charpy impact strength, unnotched	ISO 179-1	50 % of the value obtained on unstrained unexposed test specimens (see Note 3)	B4
Tensile impact strength	See Note 4	50 % of the value obtained on unstrained unexposed test specimens	B5
Any other property agreed upon	—	To be agreed	B6
NOTE 1 The state of the test specimens, the indicative property and the failure criterion shall be selected with a view to the practical service conditions.			
NOTE 2 If the material is thought to be anisotropic, two sets of specimens shall be used, one set cut at right angles to the other in two of the principal directions of orientation. This applies only to specimens having the appropriate dimensions.			
NOTE 3 Data comparisons will only be valid if the failure mode is the same in all cases.			
NOTE 4 This question is under study.			

## 4 Principle

A test specimen suitable for the determination of the indicative property is clamped with one of its faces over a form of constant radius and brought into contact with the test environment. Due to the influence of the environment in the presence of strain, crazes may be generated which with time sometimes develop into visible cracks.

By using a series of forms with decreasing radii, a series of test specimens that have increasing strains in the outer surface can be tested.

After an agreed duration of contact with the test environment, the test specimens are visually observed, unclamped and assessed by mechanical or other testing. The failure strain that corresponds to the failure criterion is obtained directly from the tabulated values or graphically.

The maximum strain must be less than the strain at yield.

NOTE 1 The failure criterion is also commonly expressed in terms of the ESC index.

NOTE 2 The failure strains for different indicative properties may be different.

## 5 Apparatus

**5.1 Forms**, made from chemical-resistant material either by machining or by bending metal sheet (for example, stainless-steel sheet). For test specimens 2 mm to 4 mm thick, radii of curvature of 30 mm to 500 mm are suitable. The form shall have roughly the same length as the test specimen.

To increase the contact between the test specimen and the test medium, the forms may be perforated.

NOTE The radius  $r$  of the segment of a circular arc of height  $h$  and chord length  $l$  is given by the equation

$$r = \frac{l^2}{8h} + \frac{h}{2}$$

**5.2 Clamps**, made from chemical-resistant material. The clamps shall be designed so that they hold the test specimen lightly. The contact between the test specimen and the form need not extend to the clamps, but shall extend over that length of test specimen which will be most highly stressed in the subsequent mechanical test. In no case shall the contact region (measured in the direction of the length of the test specimen) be less than 10 times the specimen thickness.

**5.3 Vessels**, such as carefully cleaned glass containers with well fitting lids, suitable for holding the mounted test specimens and the test medium. Other types of vessel may be used provided there is no interaction between the material of which the vessel is made and the specimens or test medium. When the contact between the test specimens and the test medium takes place under other conditions, such as exposure to a vapour or a water spray, this fact shall be reported.

**5.4 Micrometer**, capable of determining the thickness of the test specimens to within 0,01 mm.

**5.5 Apparatus for determining the indicative property** (see 8.5).

## 6 Test specimens

### 6.1 Form and dimensions

The shape and dimensions of the test specimens shall be in accordance with the relevant material standard. When no material standard exists, the shape and dimensions shall be in accordance with the test method standard.

If the test specimens are machined from sheets or articles, their thickness shall be the thickness of the sheet or article. This shall be reported, together with the original location of the specimen in the sheet or article.

### 6.2 Preparation

To obtain comparable results, the test specimens used shall have the same dimensions, state, mode of preparation and age. When cut or machined from sheet or articles, they shall be cut from corresponding places and in corresponding directions. Cut edges shall have a clean finish.

The moulding or machining conditions used for specimen preparation shall be reported.

### 6.3 Number

Unless otherwise specified, test a minimum of three specimens at each strain level (including zero strain).

## 7 Conditioning and test conditions

### 7.1 Conditioning

Unless otherwise agreed between the interested parties (e.g. for polyamides or ABS), the test specimens shall be conditioned for 48 h at  $(23 \pm 2) ^\circ\text{C}$  and  $(50 \pm 10) \%$  relative humidity before exposure to the test and reference environments.

### 7.2 Test temperature

Unless otherwise specified, the indicative property shall be determined at  $(23 \pm 2) ^\circ\text{C}$ . If other temperatures are of interest,  $(40 \pm 2) ^\circ\text{C}$  or  $(55 \pm 2) ^\circ\text{C}$  are preferred but other temperatures may be used by agreement between the interested parties. During storage in the reference environment (normally air), use the same temperature as the test temperature.

### 7.3 Test medium

See ISO 22088-1:2006, 7.3.

## 8 Procedure

### 8.1 Precautions

During all stages of testing, the test specimens shall be protected from contact with anything other than the test environment.

### 8.2 Mounting the test specimens

Clamp the cleaned test specimens to the forms, starting with zero strain and ending with the form having the smallest radius.

Care shall be taken to handle only the ends of the test specimens. If the test specimens are not clean, clean them before mounting with a liquid that has no effect on them. Cleaning may influence the test results. If specimens are cleaned prior to testing, details of the cleaning procedure shall be included in the test report.

### 8.3 Contact with the test environment

Immediately after the specimens are mounted, place them in contact with the test environment.

Contact with liquid or gases is established by immersion. Pastes shall be carefully spread to depth of 2 mm to 4 mm over the exposed surfaces of the test specimens. Solids, such as elastomers or plasticized sheet, shall be laid on the surface of the test specimen and sandwiched between this and a second test specimen. This ensures that the contact is established under a definite pressure (see Figure 2).

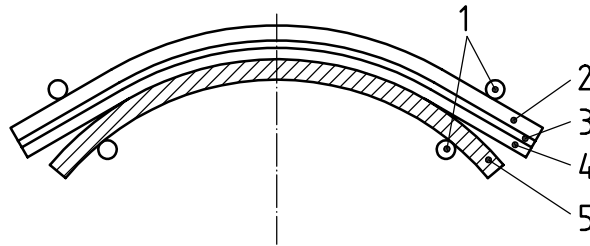

**Key**

- 1 clamps
- 2 covering test specimen
- 3 PVC sheet containing plasticizer
- 4 test specimen
- 5 form

**Figure 2 — Example of a sandwiched test specimen**

### 8.4 Storage in contact with the test environment

#### 8.4.1 Short-time test

Unless otherwise specified, keep the mounted test specimens in the test medium for 24 h ± 15 min.

#### 8.4.2 Long-term test

Keep a series of mounted test specimens in contact with the test medium, removing them for evaluation at regular intervals until any further increase in the length of the contact period is no longer accompanied by a change in the indicative property concerned.

If, at any time during the test, the specimen is not in complete contact with the central area of the form, open the clamps and reclamp the specimen so it is in full contact with the central area of the form. If this is not possible, the test shall be stopped and a new test started.

Testing shall be continued until at least 50 % of the specimens have failed or until some point in time or criterion agreed upon by all interested parties has been reached.

**NOTE** A preliminary test may be carried out with only one test specimen for each strain value to estimate the failure strain. Equal numbers of strain levels on either side of this failure strain should then be used.

## 8.5 Determination of the indicative property

Determine the indicative property in accordance with the relevant material specification. If there is no applicable material specification, use the test method relevant to the indicative property but ignore conditioning clauses and use the following procedure.

After the agreed strain time, observe the test specimen visually. When the test medium is a solid, discard it and the covering test specimen (see Figure 2).

Remove each test specimen from its form and determine the indicative property, starting with the test specimen with the lowest strain. Removing excess test medium by wiping with a clean paper tissue or clean cloth is acceptable if agreed upon by the interested parties.

Determine the indicative property as soon as possible after demounting the specimen in the short-time test and within 22 h to 24 h at  $(23 \pm 2)$  °C in air after demounting in the long-term test.

In flexural and Charpy tests, the surface of the test specimen that was not in contact with the form shall be laid on the supports.

If there is no material standard, use the following tests:

- flexural test (ISO 178): flexural stress at maximum load;
- tensile test (ISO 527-2): tensile strength at break, test speed 50 mm/min.

## 9 Expression of results

### 9.1 Calculation

Calculate the arithmetic mean value of the indicative property at each strain level.

### 9.2 Graphical evaluation

Plot the mean values thus obtained on a graph with the strain as abscissa and the value of the indicative property as ordinate. Draw a smooth curve through the points and interpolate to obtain the failure strain (see Figure 3).

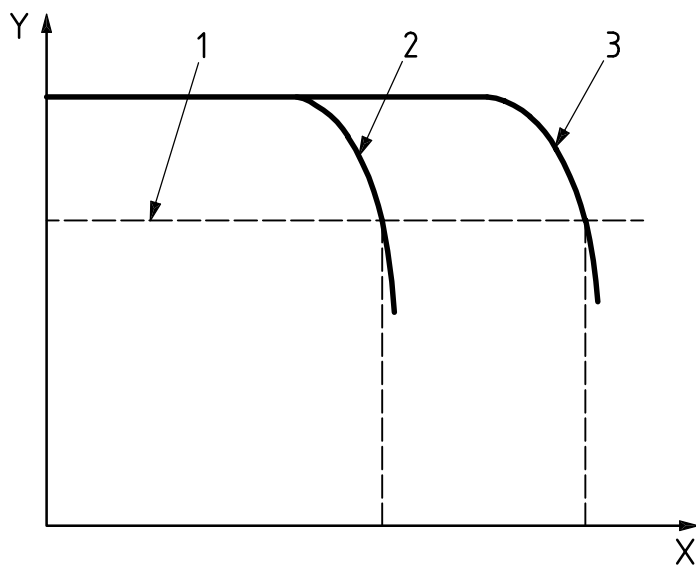

**Key**

- X strain  $\epsilon_x$
- Y indicative property
- 1 failure criterion
- 2 results in test environment
- 3 results in reference environment

**Figure 3 — Graphical evaluation of test results**

**10 Precision**

The precision of these methods is not known because interlaboratory data are not available in view of the variety of plastics materials and environmental conditions. These methods may not be suitable for use in the event of disputed results as long as no precision data are available.



## 11 Test report

The test report shall include the following particulars:

- a) a reference to this part of ISO 22088;
- b) all details necessary to identify the material tested;
- c) the test medium used;
- d) the test temperature;
- e) the number of specimens tested (if applicable, in each direction of anisotropy) and their width and thickness;
- f) the procedure used for preparation of the specimens and the cleaning procedure, if used;
- g) the state of the specimens;
- h) the conditioning time and temperature;
- i) the indicative property and the method used to determine it;
- j) the failure criterion;
- k) the individual and mean values of the indicative property;
- l) a graphical display of the results;
- m) the failure strain;
- n) the ESC index, if a reference environment was used;
- o) any visual observations (change in colour, crazing, swelling, change in gloss);
- p) any other observations;
- q) details of any deviations from the procedures specified in this part of ISO 22088;
- r) the date of testing.

## Bibliography

- [1] ISO 22088-2, *Plastics — Determination of resistance to environmental stress cracking (ESC) — Part 2: Constant tensile load method*
- [2] ISO 22088-5, *Plastics — Determination of resistance to environmental stress cracking (ESC) — Part 5: Constant tensile deformation method*



---

---

## BSI — British Standards Institution

BSI is the independent national body responsible for preparing British Standards. It presents the UK view on standards in Europe and at the international level. It is incorporated by Royal Charter.

### Revisions

British Standards are updated by amendment or revision. Users of British Standards should make sure that they possess the latest amendments or editions.

It is the constant aim of BSI to improve the quality of our products and services. We would be grateful if anyone finding an inaccuracy or ambiguity while using this British Standard would inform the Secretary of the technical committee responsible, the identity of which can be found on the inside front cover. Tel: +44 (0)20 8996 9000. Fax: +44 (0)20 8996 7400.

BSI offers members an individual updating service called PLUS which ensures that subscribers automatically receive the latest editions of standards.

### Buying standards

Orders for all BSI, international and foreign standards publications should be addressed to Customer Services. Tel: +44 (0)20 8996 9001. Fax: +44 (0)20 8996 7001. Email: [orders@bsi-global.com](mailto:orders@bsi-global.com). Standards are also available from the BSI website at <http://www.bsi-global.com>.

In response to orders for international standards, it is BSI policy to supply the BSI implementation of those that have been published as British Standards, unless otherwise requested.

### Information on standards

BSI provides a wide range of information on national, European and international standards through its Library and its Technical Help to Exporters Service. Various BSI electronic information services are also available which give details on all its products and services. Contact the Information Centre. Tel: +44 (0)20 8996 7111. Fax: +44 (0)20 8996 7048. Email: [info@bsi-global.com](mailto:info@bsi-global.com).

Subscribing members of BSI are kept up to date with standards developments and receive substantial discounts on the purchase price of standards. For details of these and other benefits contact Membership Administration. Tel: +44 (0)20 8996 7002. Fax: +44 (0)20 8996 7001. Email: [membership@bsi-global.com](mailto:membership@bsi-global.com).

Information regarding online access to British Standards via British Standards Online can be found at <http://www.bsi-global.com/bsonline>.

Further information about BSI is available on the BSI website at <http://www.bsi-global.com>.

### Copyright

Copyright subsists in all BSI publications. BSI also holds the copyright, in the UK, of the publications of the international standardization bodies. Except as permitted under the Copyright, Designs and Patents Act 1988 no extract may be reproduced, stored in a retrieval system or transmitted in any form or by any means – electronic, photocopying, recording or otherwise – without prior written permission from BSI.

This does not preclude the free use, in the course of implementing the standard, of necessary details such as symbols, and size, type or grade designations. If these details are to be used for any other purpose than implementation then the prior written permission of BSI must be obtained.

Details and advice can be obtained from the Copyright & Licensing Manager. Tel: +44 (0)20 8996 7070. Fax: +44 (0)20 8996 7553. Email: [copyright@bsi-global.com](mailto:copyright@bsi-global.com).