

Plastics — Determination of resistance to environmental stress cracking (ESC) —

Part 2: Constant tensile load method

The European Standard EN ISO 22088-2:2006 has the status of a British Standard

ICS 83.080.01

National foreword

This British Standard was published by BSI. It is the UK implementation of EN ISO 22088-2:2006. It supersedes BS EN ISO 6252:1998 which is withdrawn.

The UK participation in its preparation was entrusted to Technical Committee PRI/21, Testing of plastics.

A list of organizations represented on PRI/21 can be obtained on request to its secretary.

This publication does not purport to include all the necessary provisions of a contract. Users are responsible for its correct application.

Compliance with a British Standard cannot confer immunity from legal obligations.

This British Standard was published under the authority of the Standards Policy and Strategy Committee on 29 September 2006

© BSI 2006

ISBN 0 580 48767 9

Amendments issued since publication

| Amd. No. | Date | Comments |
|----------|------|----------|
| | | |
| | | |
| | | |
| | | |
| | | |

English Version

**Plastics - Determination of resistance to environmental stress
cracking (ESC) - Part 2: Constant tensile load method (ISO
22088-2:2006)**

Plastiques - Détermination de la fissuration sous contrainte
dans un environnement donné (ESC) - Partie 2: Méthode
sous contrainte de traction constante (ISO 22088-2:2006)

Kunststoffe - Bestimmung der Beständigkeit gegen
umgebungsbedingte Spannungsrissbildung (ESC) - Teil 2:
Zeitstandzugversuch (ISO 22088-2:2006)

This European Standard was approved by CEN on 21 July 2006.

CEN members are bound to comply with the CEN/CENELEC Internal Regulations which stipulate the conditions for giving this European Standard the status of a national standard without any alteration. Up-to-date lists and bibliographical references concerning such national standards may be obtained on application to the Central Secretariat or to any CEN member.

This European Standard exists in three official versions (English, French, German). A version in any other language made by translation under the responsibility of a CEN member into its own language and notified to the Central Secretariat has the same status as the official versions.

CEN members are the national standards bodies of Austria, Belgium, Cyprus, Czech Republic, Denmark, Estonia, Finland, France, Germany, Greece, Hungary, Iceland, Ireland, Italy, Latvia, Lithuania, Luxembourg, Malta, Netherlands, Norway, Poland, Portugal, Romania, Slovakia, Slovenia, Spain, Sweden, Switzerland and United Kingdom.



EUROPEAN COMMITTEE FOR STANDARDIZATION
COMITÉ EUROPÉEN DE NORMALISATION
EUROPÄISCHES KOMITEE FÜR NORMUNG

Management Centre: rue de Stassart, 36 B-1050 Brussels

EN ISO 22088-2:2006

Foreword

This document (EN ISO 22088-2:2006) has been prepared by Technical Committee ISO/TC 61 "Plastics" in collaboration with Technical Committee CEN/TC 249 "Plastics", the secretariat of which is held by IBN.

This European Standard shall be given the status of a national standard, either by publication of an identical text or by endorsement, at the latest by February 2007, and conflicting national standards shall be withdrawn at the latest by February 2007.

This document supersedes EN ISO 6252:1997.

According to the CEN/CENELEC Internal Regulations, the national standards organizations of the following countries are bound to implement this European Standard: Austria, Belgium, Cyprus, Czech Republic, Denmark, Estonia, Finland, France, Germany, Greece, Hungary, Iceland, Ireland, Italy, Latvia, Lithuania, Luxembourg, Malta, Netherlands, Norway, Poland, Portugal, Romania, Slovakia, Slovenia, Spain, Sweden, Switzerland and United Kingdom.

Endorsement notice

The text of ISO 22088-2:2006 has been approved by CEN as EN ISO 22088-2:2006 without any modifications.

INTERNATIONAL
STANDARD

ISO
22088-2

First edition
2006-08-15

**Plastics — Determination of resistance to
environmental stress cracking (ESC) —**

Part 2:

Constant tensile load method

*Plastiques — Détermination de la fissuration sous contrainte dans un
environnement donné (ESC) —*

Partie 2: Méthode sous contrainte de traction constante



Reference number
ISO 22088-2:2006(E)

Contents

Page

| | |
|---|-----------|
| Foreword..... | iv |
| 1 Scope | 1 |
| 2 Normative references | 1 |
| 3 Principle | 2 |
| 4 Apparatus | 2 |
| 5 Conditioning and test conditions..... | 3 |
| 5.1 Conditioning..... | 3 |
| 5.2 Test temperature..... | 3 |
| 5.3 Test medium..... | 3 |
| 6 Test stress | 4 |
| 6.1 Maximum permissible stress..... | 4 |
| 6.2 Method A..... | 4 |
| 6.3 Method B..... | 4 |
| 6.4 Method C..... | 4 |
| 7 Test specimens | 4 |
| 7.1 General..... | 4 |
| 7.2 Shape and dimensions..... | 4 |
| 7.3 Number | 5 |
| 7.4 Preparation | 5 |
| 8 Procedure | 6 |
| 9 Expression of results | 7 |
| 9.1 Method A..... | 7 |
| 9.2 Method B..... | 7 |
| 9.3 Method C..... | 7 |
| 10 Precision..... | 7 |
| 11 Test report | 8 |
| Annex A (informative) Examples of stresses to be applied | 9 |
| Bibliography | 10 |

Foreword

ISO (the International Organization for Standardization) is a worldwide federation of national standards bodies (ISO member bodies). The work of preparing International Standards is normally carried out through ISO technical committees. Each member body interested in a subject for which a technical committee has been established has the right to be represented on that committee. International organizations, governmental and non-governmental, in liaison with ISO, also take part in the work. ISO collaborates closely with the International Electrotechnical Commission (IEC) on all matters of electrotechnical standardization.

International Standards are drafted in accordance with the rules given in the ISO/IEC Directives, Part 2.

The main task of technical committees is to prepare International Standards. Draft International Standards adopted by the technical committees are circulated to the member bodies for voting. Publication as an International Standard requires approval by at least 75 % of the member bodies casting a vote.

Attention is drawn to the possibility that some of the elements of this document may be the subject of patent rights. ISO shall not be held responsible for identifying any or all such patent rights.

ISO 22088-2 was prepared by Technical Committee ISO/TC 61, *Plastics*, Subcommittee SC 6, *Ageing, chemical and environmental resistance*.

It cancels and replaces ISO 6252:1992, which has been technically revised.

ISO 22088 consists of the following parts, under the general title *Plastics — Determination of resistance to environmental stress cracking (ESC)*:

- *Part 1: General guidance*
- *Part 2: Constant tensile load method* (replacement of ISO 6252:1992)
- *Part 3: Bent strip method* (replacement of ISO 4599:1986)
- *Part 4: Ball or pin impression method* (replacement of ISO 4600:1992)
- *Part 5: Constant tensile deformation method* (new test method)
- *Part 6: Slow strain rate method* (new test method)

Plastics — Determination of resistance to environmental stress cracking (ESC) —

Part 2: Constant tensile load method

1 Scope

This part of ISO 22088 specifies methods for the determination of environmental stress cracking (ESC) of thermoplastics when they are subjected to a constant tensile load in the presence of chemical agents.

It is applicable to test specimens prepared by moulding and/or machining and can be used both for the assessment of ESC of plastic materials exposed to different environments, and for the determination of ESC of different plastic materials exposed to a specific environment.

This is essentially a ranking test and is not intended to provide data to be used for design or performance prediction.

NOTE Methods for the determination of environmental stress cracking by means of a constant-strain test are specified in ISO 22088-3, ISO 22088-4 and ISO 22088-5.

2 Normative references

The following referenced documents are indispensable for the application of this document. For dated references, only the edition cited applies. For undated references, the latest edition of the referenced document (including any amendments) applies.

ISO 293, *Plastics — Compression moulding of test specimens of thermoplastic materials*

ISO 294-1, *Plastics — Injection moulding of test specimens of thermoplastic materials — Part 1: General principles, and moulding of multipurpose and bar test specimens*

ISO 527-2:1993, *Plastics — Determination of tensile properties — Part 2: Test conditions for moulding and extrusion plastics*

ISO 2818, *Plastics — Preparation of test specimens by machining*

ISO 3167, *Plastics — Multipurpose test specimens*

ISO 22088-1:2006, *Plastics — Determination of resistance to environmental stress cracking (ESC) — Part 1: General guidance*

3 Principle

A test specimen is subjected to a constant tensile load, corresponding to a stress lower than that at yield, while immersed in a specified environment at the temperature selected for testing. The time and/or stress at which the specimen breaks is recorded.

The environmental stress cracking of the test specimens is determined by one of the following methods (A, B or C), depending upon the time to rupture:

- Method A: Determination of the tensile stress leading to rupture at 100 h. This stress is obtained by interpolation of the graph of time to rupture versus applied tensile stress.
- Method B: Determination of the time to rupture under a specified tensile stress. This method is used when the time to rupture exceeds 100 h.
- Method C: Determination of the time to rupture for a series of applied stresses. The graph of time to rupture versus applied stress is then examined to determine if the rupture time for some agreed-upon applied stress is satisfactory.

4 Apparatus

4.1 Test device, allowing test specimens to be simultaneously subjected to a tensile load and exposed to a chemical environment.

If the chemical is a liquid at the test temperature, the test specimen shall be completely immersed. If it is highly viscous at the test temperature, the specimen may be covered with a coating of the agent at least 2 mm thick (see Clause 5).

Parts of the device that come into contact with the test medium shall be made of an inert material.

The constant tensile load may be applied with weights (Figure 1 is a schematic diagram of a suitable apparatus). The force shall be accurate to $\pm 1\%$ of the specified force. It is important to ensure that there is no unintended contact between moving parts, and that all moving parts of the apparatus are properly maintained and lubricated as appropriate.

If the test device has several test stations, means shall be provided to prevent the vibration occurring through failure at one station from being transmitted to the whole system.

Unless otherwise specified, forces shall be applied parallel to the longitudinal axis.

NOTE Bending or twisting forces will produce different stresses and may affect the results and increase test variability.

4.2 Temperature-controlled bath or room, allowing the containers to be maintained at $(23 \pm 2)^\circ\text{C}$ or at a higher test temperature up to $(105 \pm 2)^\circ\text{C}$ (see 5.2).

4.3 Automatic timer, as shown schematically in Figure 1, to measure the time to rupture of each specimen to within $\pm 1\%$ of the elapsed time.

4.4 Equipment for the preparation of test specimens by moulding (see ISO 293 and ISO 294-1), machining (see ISO 2818) or die cutting.

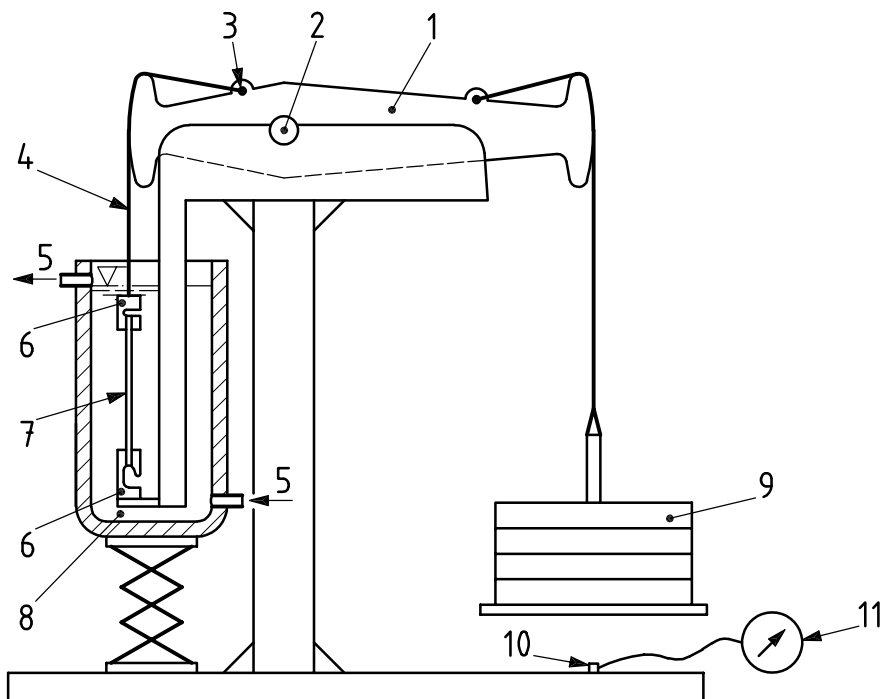

Key

- | | | | |
|---|--|----|--------------------------|
| 1 | balance | 7 | test specimen |
| 2 | frictionless bearing, or knife edge | 8 | chemical environment |
| 3 | wire attachment point | 9 | weights |
| 4 | wire | 10 | switch controlling timer |
| 5 | circulation of temperature-controlled liquid | 11 | timer |
| 6 | clamps | | |

Figure 1 — One type of apparatus for measuring fracture under constant load

5 Conditioning and test conditions

5.1 Conditioning

Unless otherwise agreed between the interested parties, the test specimens shall be conditioned before testing for at least 24 h at $(23 \pm 2)^\circ\text{C}$ and $(50 \pm 10)\%$ relative humidity.

5.2 Test temperature

The preferred test temperatures are $(23 \pm 2)^\circ\text{C}$ and $(55 \pm 2)^\circ\text{C}$. If required, other temperatures may be used, preferably selected from the following:

$(40 \pm 2)^\circ\text{C}$, $(70 \pm 2)^\circ\text{C}$, $(85 \pm 2)^\circ\text{C}$, $(100 \pm 2)^\circ\text{C}$

or as agreed upon by the interested parties.

5.3 Test medium

See ISO 22088-1:2006, 7.3.

6 Test stress

6.1 Maximum permissible stress

The stress applied to the test specimen during the test shall be less than the tensile stress at yield of the material at the temperature of the test.

NOTE As a general guide, the stress that produces an elongation of 2 % after 1 h can be taken as the maximum permissible stress. This stress can be determined by preliminary tests using several different stresses.

6.2 Method A

Conduct tests at a series of applied stress levels to determine the applied stress that will cause failure in 100 h. Test a minimum of five specimens at each applied stress. The applied stress needed to produce failure in 100 h is calculated as described in 9.1.

6.3 Method B

Determine the time to rupture under a single stress agreed between the interested parties, but not higher than the maximum permissible stress defined in 6.1.

6.4 Method C

Determine the times to rupture for agreed-upon applied stresses. The series of stresses shall be chosen in accordance with 8.7. Test a minimum of two specimens at each applied stress. The result is reported as the time to rupture for a particular applied stress. Method A is a subset of method C.

7 Test specimens

7.1 General

When moulding test specimens, or when machining and polishing test specimens cut from large sheets or products, it is important to minimize any residual stress. Use the mildest conditions possible during specimen preparation. Annealing specimens prior to testing is recommended. Report the exact conditions used for specimen preparation and the conditions used for any annealing of specimens prior to testing.

7.2 Shape and dimensions

Wherever possible, use the type 1BA small test specimen specified in Annex A of ISO 527-2:1993, as shown in Figure 2.

The preferred thickness is $(2 \pm 0,2)$ mm, but when the test specimens are prepared from finished products the thickness may be that of the product. Alternatively, a type 1BA specimen 3 mm to 4 mm thick may be used.

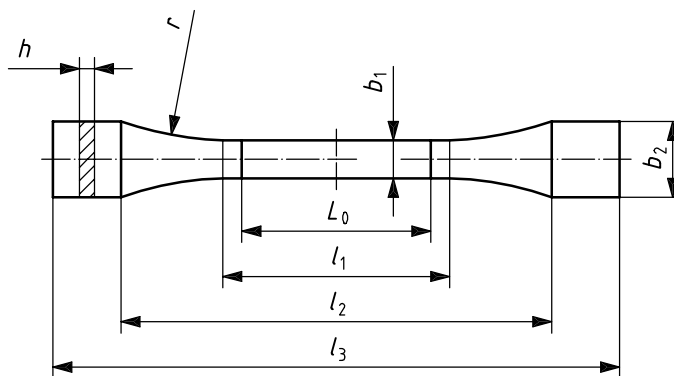
**Key**

| | | |
|-------|---|-----------------------------|
| l_3 | overall length: | 75 mm |
| b_2 | width at ends: | $(10 \pm 0,5)$ mm |
| l_1 | length of narrow, parallel-sided portion: | $(30 \pm 0,5)$ mm |
| b_1 | width of narrow, parallel-sided portion: | $(5 \pm 0,5)$ mm |
| r | radius, minimum: | 30 mm |
| h | thickness: | preferably $(2 \pm 0,2)$ mm |
| l_0 | distance between gauge marks: | 25 mm |
| l_2 | initial distance between grips: | 57 mm |

Figure 2 — ISO 527-2 type 1BA specimen (type 1B scaled down 2:1)

7.3 Number

At least five specimens shall be tested at each tensile stress in the case of methods A and B, and at least two specimens for each stress in the case of method C.

If the material is thought to be anisotropic, two sets of specimens shall be used, one set cut at right angles to the other in two of the principal directions of orientation.

7.4 Preparation

The specimens shall be prepared in accordance with the appropriate International Standard. If nothing is stated, specimens shall be machined from sheet or from products by methods specified in ISO 2818.

If sheets are prepared from moulding materials, they shall be moulded in accordance with the relevant material specification or as agreed between the interested parties. Specimens shall not be cut with a die unless machining is impossible, for example with soft materials. For preparation of test specimens, use the procedures described in ISO 293, ISO 294-1 or ISO 3167.

NOTE Environmental stress cracking of a specimen is influenced not only by the material, but also by the method of preparation of the specimen. Materials should only be compared using specimens prepared in a similar manner and in the same state.

8 Procedure

8.1 Measure, to the nearest 0,01 mm, the thickness and the width of the central, parallel-sided portion of each specimen and calculate the force F , in newtons, to be applied, using the equation

$$F = \sigma A$$

where

σ is the stress, in megapascals, selected for the test (see Clause 6);

A is the cross-sectional area, in square millimetres, of the central, parallel-sided portion of the specimen.

NOTE The following procedure is recommended for determining the cross-sectional area:

- a) measure the thickness at each end of the parallel-sided portion and take the minimum value;
- b) measure the width of each face at each end of the parallel-sided portion and take the mean value.

8.2 Heat the temperature-controlled bath or room (4.2) to the selected test temperature.

8.3 Insert the specimens in the clamps of the test device (4.1) and immerse them in the test liquid or coat them with the chemical. Suitable clamping arrangements are shown schematically in Figure 3.

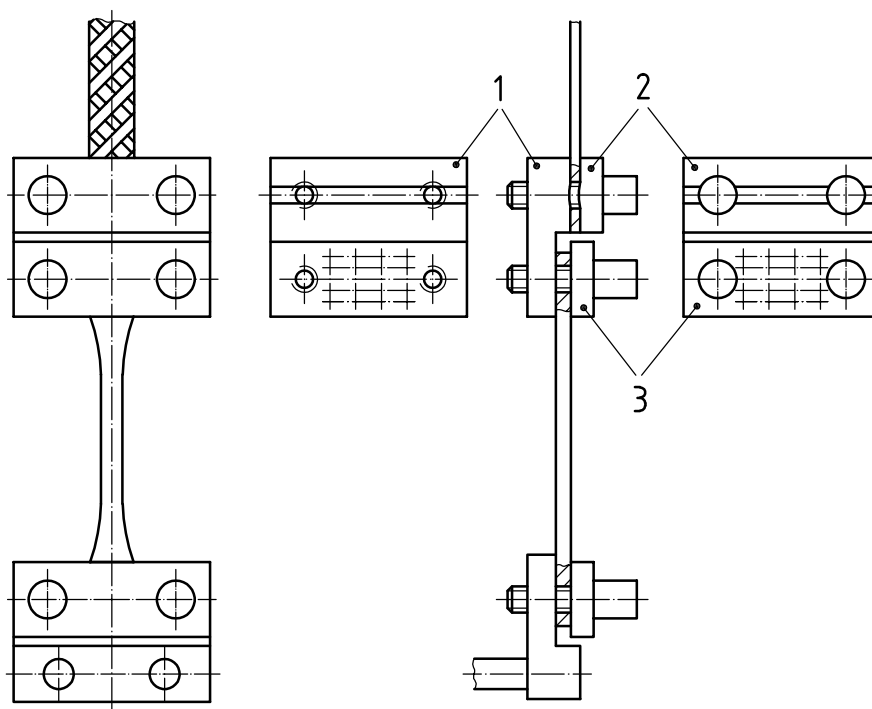

Key

- 1 specimen fixing plate
- 2 clamping jaw for load application braid
- 3 specimen clamping jaw

Figure 3 — Example of suitable clamp arrangement

8.4 After 15 min, apply the load F to each specimen, without shock, in such a way that the loading time is preferably between 3 s and 5 s and in any case less than 10 s. Start the timer (4.3) as soon as the load is applied ($t = 0$). Record the time to rupture for each specimen and the type of break (brittle or ductile).

If a liquid chemical environment is used, it shall be renewed with liquid from the same batch for each test specimen (apparatus with one station) or each group of test specimens (apparatus with several stations).

8.5 When method A is used, perform the test with a series of tensile stresses up to and including the maximum permissible as defined in 6.1.

NOTE The 100 h stress is obtained by interpolation of a stress versus log time plot (see 9.1). If the logarithm of the arithmetic mean of the times to rupture is used, the longer times are overemphasized. A more conservative assessment of the times to rupture can be obtained by calculating the mean of the logarithms of the measured times to rupture, i.e. the geometric mean.

8.6 When method B is used, perform the test using a specified or agreed stress not higher than the maximum permissible stress as defined in 6.1 (see 6.3). If no break occurs after 1 000 h, terminate the test and record this fact in the test report.

8.7 When method C is used, perform the test using a series of stresses. The loads shall be chosen so as to fall within the range from 10 % to 90 % of the short-time tensile strength of the material and shall be selected from the following numbers: 1; 2; 3; 5; 7,5; 10 and their decimal multiples.

8.8 If required, carry out a parallel series of tests, as described in 8.5 or 8.6, in air or another reference environment.

9 Expression of results

9.1 Method A

Calculate the arithmetic mean and the standard deviation of the measured times to rupture. Plot the logarithm of the mean, in hours, as abscissa versus tensile stress, in megapascals, as ordinate and determine by interpolation the stress corresponding to a time to rupture of 100 h.

9.2 Method B

Calculate the arithmetic mean of the times to rupture, in hours, obtained from at least five specimens and the standard deviation.

NOTE For some purposes, the geometric, rather than the arithmetic, mean may be found useful because the logarithms of the times to rupture often show a better Gaussian distribution than the times to rupture.

9.3 Method C

Calculate the arithmetic mean of the times to rupture for each stress used. Plot the logarithm of each mean time to rupture, in hours, as abscissa versus tensile stress, in megapascals, as ordinate.

10 Precision

The precision of these methods is not known because interlaboratory data are not available in view of the variety of plastics materials and environmental conditions. These methods may not be suitable for use in the event of disputed results as long as no precision data are available.

11 Test report

The test report shall include the following particulars:

- a) a reference to this part of ISO 22088;
- b) the test method used (method A, B or C);
- c) all details necessary to identify the material tested;
- d) the test medium used;
- e) the test temperature;
- f) the number of specimens tested (if applicable, in each direction of anisotropy) and their width and thickness;
- g) the procedure used for preparation of the specimens;
- h) the state of the specimens;
- i) the conditioning duration and atmosphere;
- j) the stresses applied;
- k) the individual and mean values for time to rupture for each stress applied (if no rupture occurs after 1 000 h using the maximum stress as defined in 6.1, report that fact);
- l) for method A, the stress corresponding to 100 h time to rupture;
- m) the type of break, i.e. brittle or ductile;
- n) any operational details not specified in this International Standard, and any circumstance liable to have influenced the results;
- o) results from parallel series of tests in air or another reference environment, if obtained;
- p) the date of testing.

Annex A (informative)

Examples of stresses to be applied

| Type of plastic | Temperature °C | Maximum stress to be applied MPa |
|-----------------------------|-------------------|--|
| Polyamide 66 | 55 | 30 |
| Polycarbonate | 55 | 40 |
| Polycarbonate | 23 | 50 |
| PVC (unplasticized) | 55 | 21 |
| Polyethylene (high density) | 55 | 4 to 7 depending on the molecular mass |
| Poly(methyl methacrylate) | 55 | 25 |
| Poly(methyl methacrylate) | 23 | 40 |
| Poly(oxymethylene) | 55 | 28 |

NOTE These values are given for information only. The maximum permissible stress is dependent upon the molecular mass of the polymer tested.

Bibliography

- [1] ISO 22088-3, *Plastics — Determination of resistance to environmental stress cracking (ESC) — Part 3: Bent strip method*
- [2] ISO 22088-4, *Plastics — Determination of resistance to environmental stress cracking (ESC) — Part 4: Ball or pin impression method*
- [3] ISO 22088-5, *Plastics — Determination of resistance to environmental stress cracking (ESC) — Part 5: Constant tensile deformation method*

BSI — British Standards Institution

BSI is the independent national body responsible for preparing British Standards. It presents the UK view on standards in Europe and at the international level. It is incorporated by Royal Charter.

Revisions

British Standards are updated by amendment or revision. Users of British Standards should make sure that they possess the latest amendments or editions.

It is the constant aim of BSI to improve the quality of our products and services. We would be grateful if anyone finding an inaccuracy or ambiguity while using this British Standard would inform the Secretary of the technical committee responsible, the identity of which can be found on the inside front cover. Tel: +44 (0)20 8996 9000. Fax: +44 (0)20 8996 7400.

BSI offers members an individual updating service called PLUS which ensures that subscribers automatically receive the latest editions of standards.

Buying standards

Orders for all BSI, international and foreign standards publications should be addressed to Customer Services. Tel: +44 (0)20 8996 9001. Fax: +44 (0)20 8996 7001. Email: orders@bsi-global.com. Standards are also available from the BSI website at <http://www.bsi-global.com>.

In response to orders for international standards, it is BSI policy to supply the BSI implementation of those that have been published as British Standards, unless otherwise requested.

Information on standards

BSI provides a wide range of information on national, European and international standards through its Library and its Technical Help to Exporters Service. Various BSI electronic information services are also available which give details on all its products and services. Contact the Information Centre. Tel: +44 (0)20 8996 7111. Fax: +44 (0)20 8996 7048. Email: info@bsi-global.com.

Subscribing members of BSI are kept up to date with standards developments and receive substantial discounts on the purchase price of standards. For details of these and other benefits contact Membership Administration. Tel: +44 (0)20 8996 7002. Fax: +44 (0)20 8996 7001. Email: membership@bsi-global.com.

Information regarding online access to British Standards via British Standards Online can be found at <http://www.bsi-global.com/bsonline>.

Further information about BSI is available on the BSI website at <http://www.bsi-global.com>.

Copyright

Copyright subsists in all BSI publications. BSI also holds the copyright, in the UK, of the publications of the international standardization bodies. Except as permitted under the Copyright, Designs and Patents Act 1988 no extract may be reproduced, stored in a retrieval system or transmitted in any form or by any means – electronic, photocopying, recording or otherwise – without prior written permission from BSI.

This does not preclude the free use, in the course of implementing the standard, of necessary details such as symbols, and size, type or grade designations. If these details are to be used for any other purpose than implementation then the prior written permission of BSI must be obtained.

Details and advice can be obtained from the Copyright & Licensing Manager. Tel: +44 (0)20 8996 7070. Fax: +44 (0)20 8996 7553. Email: copyright@bsi-global.com.