

Petroleum and related products — Determination of the flammability characteristics of fluids in contact with hot surfaces — Manifold ignition test

The European Standard EN ISO 20823:2003 has the status of a British Standard

ICS 75.080

National foreword

This British Standard is the official English language version of EN ISO 20823:2003. It is identical with ISO 20823:2003

The UK participation in its preparation was entrusted to Technical Committee PTI/13, Petroleum testing and terminology, which has the responsibility to:

- aid enquirers to understand the text;
- present to the responsible international/European committee any enquiries on the interpretation, or proposals for change, and keep the UK interests informed;
- monitor related international and European developments and promulgate them in the UK.

A list of organizations represented on this committee can be obtained on request to its secretary.

Cross-references

The British Standards which implement international or European publications referred to in this document may be found in the *BSI Catalogue* under the section entitled “International Standards Correspondence Index”, or by using the “Search” facility of the *BSI Electronic Catalogue* or of British Standards Online.

This publication does not purport to include all the necessary provisions of a contract. Users are responsible for its correct application.

Compliance with a British Standard does not of itself confer immunity from legal obligations.

Summary of pages

This document comprises a front cover, an inside front cover, the EN ISO title page, the EN ISO foreword page, the ISO title page, pages ii and iii, a blank page, pages 1 to 5, the Annex ZA page, an inside back cover and a back cover.

The BSI copyright notice displayed in this document indicates when the document was last issued.

Amendments issued since publication

Amd. No.	Date	Comments

This British Standard was published under the authority of the Standards Policy and Strategy Committee on 13 August 2003

© BSI 13 August 2003

ISBN 0 580 42451 0

ICS 75.080

English version

**Petroleum and related products - Determination of the
flammability characteristics of fluids in contact with hot surfaces
- Manifold ignition test (ISO 20823:2003)**

Pétrole et produits connexes - Détermination des
caractéristiques d'inflammabilité de fluides au contact de
surfaces chaudes - Essai d'inflammation sur métal chaud
(ISO 20823:2003)

Mineralölerzeugnisse und verwandte Produkte -
Bestimmung der Entflammbarkeits-Charakteristik von
Flüssigkeiten bei Kontakt mit heißen Oberflächen -
Zündverfahren (ISO 20823:2003)

This European Standard was approved by CEN on 2 July 2003.

CEN members are bound to comply with the CEN/GENELEC Internal Regulations which stipulate the conditions for giving this European Standard the status of a national standard without any alteration. Up-to-date lists and bibliographical references concerning such national standards may be obtained on application to the Management Centre or to any CEN member.

This European Standard exists in three official versions (English, French, German). A version in any other language made by translation under the responsibility of a CEN member into its own language and notified to the Management Centre has the same status as the official versions.

CEN members are the national standards bodies of Austria, Belgium, Czech Republic, Denmark, Finland, France, Germany, Greece, Hungary, Iceland, Ireland, Italy, Luxembourg, Malta, Netherlands, Norway, Portugal, Slovakia, Spain, Sweden, Switzerland and United Kingdom.



EUROPEAN COMMITTEE FOR STANDARDIZATION
COMITÉ EUROPÉEN DE NORMALISATION
EUROPÄISCHES KOMITEE FÜR NORMUNG

Management Centre: rue de Stassart, 36 B-1050 Brussels

Foreword

This document (EN ISO 20823:2003) has been prepared by Technical Committee ISO/TC 28 "Petroleum products and lubricants" in collaboration with Technical Committee CEN/TC 19 "Petroleum products, lubricants and related products", the secretariat of which is held by NEN.

This European Standard shall be given the status of a national standard, either by publication of an identical text or by endorsement, at the latest by February 2004, and conflicting national standards shall be withdrawn at the latest by February 2004.

According to the CEN/CENELEC Internal Regulations, the national standards organizations of the following countries are bound to implement this European Standard: Austria, Belgium, Czech Republic, Denmark, Finland, France, Germany, Greece, Hungary, Iceland, Ireland, Italy, Luxembourg, Malta, Netherlands, Norway, Portugal, Slovakia, Spain, Sweden, Switzerland and the United Kingdom.

Endorsement notice

The text of ISO 20823:2003 has been approved by CEN as EN ISO 20823:2003 without any modifications.

NOTE Normative references to International Standards are listed in Annex ZA (normative).

INTERNATIONAL
STANDARD

ISO
20823

First edition
2003-08-01

**Petroleum and related products —
Determination of the flammability
characteristics of fluids in contact with
hot surfaces — Manifold ignition test**

*Pétrole et produits connexes — Détermination des caractéristiques
d'inflammabilité de fluides au contact de surfaces chaudes — Essai
d'inflammation sur métal chaud*



Reference number
ISO 20823:2003(E)

Foreword

ISO (the International Organization for Standardization) is a worldwide federation of national standards bodies (ISO member bodies). The work of preparing International Standards is normally carried out through ISO technical committees. Each member body interested in a subject for which a technical committee has been established has the right to be represented on that committee. International organizations, governmental and non-governmental, in liaison with ISO, also take part in the work. ISO collaborates closely with the International Electrotechnical Commission (IEC) on all matters of electrotechnical standardization.

International Standards are drafted in accordance with the rules given in the ISO/IEC Directives, Part 2.

The main task of technical committees is to prepare International Standards. Draft International Standards adopted by the technical committees are circulated to the member bodies for voting. Publication as an International Standard requires approval by at least 75 % of the member bodies casting a vote.

Attention is drawn to the possibility that some of the elements of this document may be the subject of patent rights. ISO shall not be held responsible for identifying any or all such patent rights.

ISO 20823 was prepared by Technical Committee ISO/TC 28, *Petroleum products and lubricants*.

Petroleum and related products — Determination of the flammability characteristics of fluids in contact with hot surfaces — Manifold ignition test

WARNING — The use of this International Standard may involve hazardous materials, operations and equipment. This International Standard does not purport to address all of the safety problems associated with its use. It is the responsibility of the user of this International Standard to establish appropriate safety and health practices and determine the applicability of regulatory limitations prior to use.

1 Scope

This International Standard specifies a test method to determine the relative flammability of fluids when contacted with a hot metal surface at a fixed temperature, but it is also possible to gauge fluid ignition temperatures by adjustment of the manifold temperature.

It is primarily used to assess the resistance to ignition of fire-resistant hydraulic fluids which are, by definition, difficult to ignite.

It may be used with other types of more flammable fluids at lower surface temperatures, but this could significantly increase the hazards of this procedure.

NOTE The procedure given in this International Standard is specified in ISO 12922:1999, *Lubricants, industrial oils and related products (class L) — Family H (Hydraulic systems) — Specifications for categories HFAE, HFAS, HFB, HFC, HFDR and HFDU*.

2 Normative references

The following referenced documents are indispensable for the application of this document. For dated references, only the edition cited applies. For undated references, the latest edition of the referenced document (including any amendments) applies.

ISO 3170:—¹⁾, *Petroleum liquids — Manual sampling*

3 Principle

A 10 ml test portion of fluid is dropped from a predetermined height and at a specified rate, onto a tube heated to 700 °C, or another temperature in a series. The resulting spray is examined for flash or burn, both on the tube and after dripping from the tube.

¹⁾ To be published. (Revision of ISO 3170:1988)

4 Reagents and materials

4.1 Steel wool

4.2 Absorbent cotton (cotton wool)

4.3 Cleaning solvent: any suitable light hydrocarbon solvent for wiping the tube.

NOTE 2,2,4-trimethylpentane, heptane or petroleum spirit boiling between 60 °C and 80 °C are suitable.

5 Apparatus

5.1 Simulated manifold test rig

5.1.1 General

The rig consists of a heated simulated manifold supported in a box frame, and is illustrated in Figure 1. It shall be located in a fire-resistant enclosure with adequate ventilation to remove toxic and/or noxious combustion or decomposition products.

5.1.2 Manifold support

A sheet metal box of dimensions 300 mm × 300 mm × 450 mm, open at the top and front. Holes of 78 mm nominal diameter shall be cut in the sides in such a position that the manifold is positioned and supported so that its major axis is held at an angle of 7° to the horizontal, and the centre-point of the manifold is 270 mm ± 10 mm above the surface of the drip tray or bottom of the support. The bottom of the box shall either contain a separate drip tray, or be so shaped as to contain all drips of liquid falling from the manifold.

The diameter of the holes in the box should be just sufficient to accommodate the simulated manifold (5.1.3) complete with external rod.

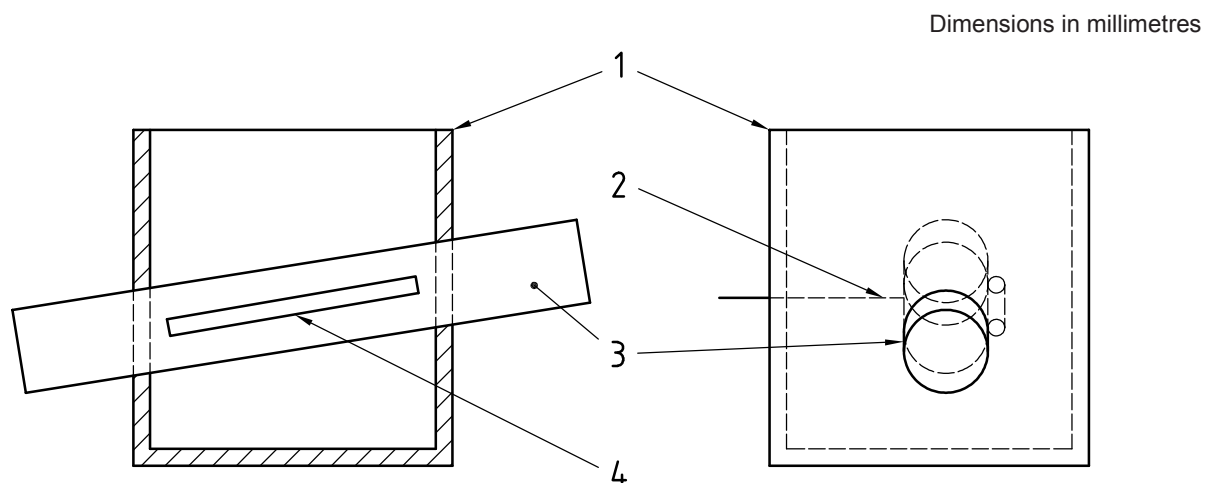

Key

- 1 sheet metal box 300 × 300 × 450
- 2 thermocouple
- 3 tube of corrosion-resistant steel: 75 outer diameter × 1 wall thickness × 500
- 4 rod of corrosion-resistant steel: diameter 3 × 250

Figure 1 — Simulated manifold test rig

5.1.3 Simulated manifold

The manifold, illustrated in Figure 2, is constructed from corrosion-resistant steel tubing of 75 mm nominal outside diameter and 1 mm wall thickness. It shall be 500 mm \pm 50 mm in length. The exterior of the tube shall be sandblasted. A corrosion-resistant steel rod, 3 mm in diameter and 250 mm in length, is tack welded to the exterior surface of the tube such that the major axes are parallel, and the mid-point of the long axis of the rod corresponds to that of the tube.

5.1.4 Manifold heater

A heating element shall be mounted centrally within the manifold tube by means of suitable washers constructed from thermal insulation material. The element shall be capable of heating and maintaining a temperature of 700 °C \pm 5 °C on the exterior surface of the manifold tube over the central portion of approximately 305 mm of the tube, whilst the enclosure ventilation (5.1.1) is switched on. The terminals to the tube heater shall be enclosed.

NOTE A rod pattern, silicon carbide type or equivalent, of 25 mm diameter and overall length 790 mm, and nominal electrical resistance 0,62 Ω , has been found suitable.

5.1.5 Temperature sensors

Temperature sensors shall be mounted in contact with the manifold tube surface in order to monitor the temperature close to the expected point of impact of the fluid. Each sensor shall be connected to a temperature indicator. Take care to minimize any additional radiating surfaces in the attachment of the sensor(s).

NOTE A mobile spring-loaded plate temperature sensor is preferred. If not available, three sensors located approximately 145 mm apart over the central portion of the manifold tube surface, placed to avoid fluid running off across the sensors, will be satisfactory.

5.2 Fluid dispenser

A device, mounted vertically above the centre-line of the manifold, that can measure 10 ml \pm 0,5 ml of fluid, and dispense it at a controlled and constant rate over 50 s \pm 10 s. The dispenser shall be mounted on a stand that allows measured movements horizontally along the axis of the tube and parallel to it. The height of the dispenser outlet above the surface shall be measured and recorded.

NOTE Manual use of a burette or similar device is not recommended in view of the safety hazard associated with the fluid igniting on the manifold.

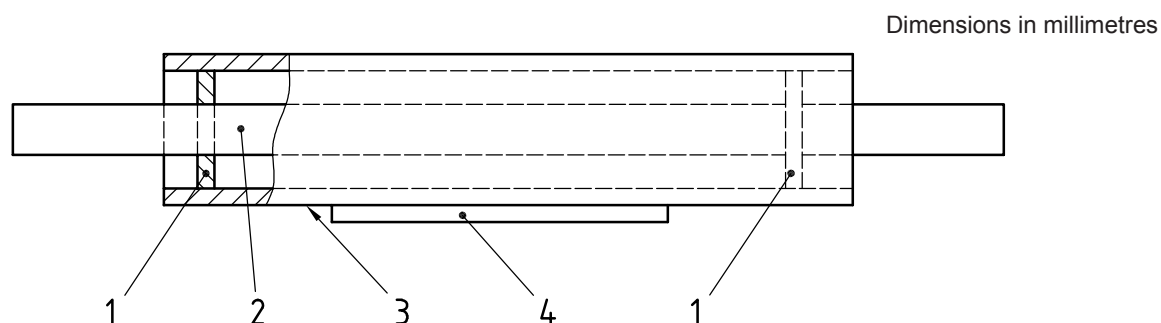

Key

- 1 packing to hold central element in tube
- 2 heating element
- 3 tube of corrosion-resistant steel: 75 outer diameter \times 1 wall thickness \times 500
- 4 rod of corrosion-resistant steel: diameter 3 \times 250

Figure 2 — Simulated manifold and heating element

6 Samples and sampling

6.1 Unless otherwise specified, samples shall be taken in accordance with the procedures specified in ISO 3170 or an equivalent national standard.

6.2 Laboratory samples shall be mixed thoroughly by shaking vigorously for 30 s before taking the test portion. The test portion shall not be filtered, but any air bubbles which may have arisen during mixing shall be allowed to escape from the fluid before testing.

7 Procedure

7.1 Clean the outside surface of the manifold tube, which shall be at approximately room temperature, by rubbing with steel wool (4.1), followed by lint-free absorbent cotton (4.2) moistened with cleaning solvent (4.3), and finally with dry absorbent cotton. Ensure that no metallic particles are left on the surface. If the area of contact for the three tests leading to a result is known (see 7.3 and 7.6), clean this total surface area and not between individual tests.

NOTE Cleaning of the manifold tube between tests is preferably carried out without removal from the support, but with the heating element electrically isolated or removed.

7.2 Place the tube in the manifold support (5.1.2) and mount and connect the heating element. Switch on the manifold heater (5.1.4) and allow the surface temperature to equilibrate to $700\text{ °C} \pm 5\text{ °C}$ at the expected point of contact, as indicated by the temperature sensor(s) (5.1.5).

7.3 Mount the dispenser outlet vertically above the axis of the manifold tube and 300 mm above its surface. Fill the dispenser with a 10 ml test portion of fluid at 20 °C to 25 °C . If three repeat tests are to be carried out on a single cleaned tube portion, start at the lowest position on the tube and move upwards.

If a motorized dispenser is used, a larger volume of fluid may actually be added, but the equipment should be able to dispense the correct volume during the specified time period.

7.4 With the manifold tube equilibrated at 700 °C , dispense the fluid onto the tube at a constant rate so that the 10 ml test portion is expelled in 40 s to 60 s. Observe the behaviour of the fluid both on the surface of the tube and as it drips from the rod into the tray below.

NOTE The means of dispenser control will depend upon dispenser type. It may help if preliminary tests establish a suitable control, such as premarking of the tip opening device.

7.5 Record any flashes or burning on the tube or when collected in the tray below.

7.6 Repeat the test twice more at the same temperature by following the procedure given in 7.2 to 7.5 at new positions on the tube, each at least 50 mm higher up the tube from the previous contact area.

7.7 If an assessment of ignition temperature is required, select the new temperature below or above 700 °C as indicated from the result at that temperature, and repeat 7.1 to 7.6.

8 Expression of results

Report the average height, to the nearest 5 mm, of the fluid dispenser outlet above the surface of the manifold tube.

Report the result in one of the following categories:

- a) "I(T)" when the fluid flashes or burns on the tube, but does not continue to burn when collected in the tray below;

- b) "I(D)" when the fluid flashes or burns on the tube, and continues to do so when collected in the tray below;
- c) "N" when the fluid does not flash or burn at any time.

NOTE Category "N" may also be described as "pass".

9 Precision

It is not possible to generate precision in a conventional manner on such a procedure, both due to the individual nature of the various items of test apparatus and conditions, and the descriptive nature of the results. Each laboratory shall produce a quality-control procedure based on fluids of known performance against which other fluids are ranked.

10 Test report

The test report shall contain at least the following information:

- a) a reference to this International Standard;
- b) the type and complete identification of the product tested;
- c) the result of the test (see Clause 8);
- d) any deviation, by agreement or otherwise, from the procedures specified;
- e) the date of the test.

Annex ZA
(normative)**Normative references to international publications
with their relevant European publications**

This European Standard incorporates by dated or undated reference, provisions from other publications. These normative references are cited at the appropriate places in the text and the publications are listed hereafter. For dated references, subsequent amendments to or revisions of any of these publications apply to this European Standard only when incorporated in it by amendment or revision. For undated references the latest edition of the publication referred to applies (including amendments).

NOTE Where an International Publication has been modified by common modifications, indicated by (mod.), the relevant EN/HD applies.

<u>Publication</u>	<u>Year</u>	<u>Title</u>	<u>EN</u>	<u>Year</u>
ISO 3170	1988	Petroleum liquids - Manual sampling	EN ISO 3170	1998

BSI — British Standards Institution

BSI is the independent national body responsible for preparing British Standards. It presents the UK view on standards in Europe and at the international level. It is incorporated by Royal Charter.

Revisions

British Standards are updated by amendment or revision. Users of British Standards should make sure that they possess the latest amendments or editions.

It is the constant aim of BSI to improve the quality of our products and services. We would be grateful if anyone finding an inaccuracy or ambiguity while using this British Standard would inform the Secretary of the technical committee responsible, the identity of which can be found on the inside front cover.
Tel: +44 (0)20 8996 9000. Fax: +44 (0)20 8996 7400.

BSI offers members an individual updating service called PLUS which ensures that subscribers automatically receive the latest editions of standards.

Buying standards

Orders for all BSI, international and foreign standards publications should be addressed to Customer Services. Tel: +44 (0)20 8996 9001.
Fax: +44 (0)20 8996 7001. Email: orders@bsi-global.com. Standards are also available from the BSI website at <http://www.bsi-global.com>.

In response to orders for international standards, it is BSI policy to supply the BSI implementation of those that have been published as British Standards, unless otherwise requested.

Information on standards

BSI provides a wide range of information on national, European and international standards through its Library and its Technical Help to Exporters Service. Various BSI electronic information services are also available which give details on all its products and services. Contact the Information Centre.
Tel: +44 (0)20 8996 7111. Fax: +44 (0)20 8996 7048. Email: info@bsi-global.com.

Subscribing members of BSI are kept up to date with standards developments and receive substantial discounts on the purchase price of standards. For details of these and other benefits contact Membership Administration.
Tel: +44 (0)20 8996 7002. Fax: +44 (0)20 8996 7001.
Email: membership@bsi-global.com.

Information regarding online access to British Standards via British Standards Online can be found at <http://www.bsi-global.com/bsonline>.

Further information about BSI is available on the BSI website at <http://www.bsi-global.com>.

Copyright

Copyright subsists in all BSI publications. BSI also holds the copyright, in the UK, of the publications of the international standardization bodies. Except as permitted under the Copyright, Designs and Patents Act 1988 no extract may be reproduced, stored in a retrieval system or transmitted in any form or by any means – electronic, photocopying, recording or otherwise – without prior written permission from BSI.

This does not preclude the free use, in the course of implementing the standard, of necessary details such as symbols, and size, type or grade designations. If these details are to be used for any other purpose than implementation then the prior written permission of BSI must be obtained.

Details and advice can be obtained from the Copyright & Licensing Manager.
Tel: +44 (0)20 8996 7070. Fax: +44 (0)20 8996 7553.
Email: copyright@bsi-global.com.