

Water quality — Determination of selected phthalates using gas chromatography/ mass spectrometry

The European Standard EN ISO 18856:2005 has the status of a British Standard

ICS 13.060.50

Confirmed
July 2008

National foreword

This British Standard is the official English language version of EN ISO 18856:2005. It is identical with ISO 18856:2004.

The UK participation in its preparation was entrusted by Technical Committee EH/3, Water quality, to Subcommittee EH/3/2, Physical, chemical and biochemical methods, which has the responsibility to:

- aid enquirers to understand the text;
- present to the responsible international/European committee any enquiries on the interpretation, or proposals for change, and keep UK interests informed;
- monitor related international and European developments and promulgate them in the UK.

A list of organizations represented on this subcommittee can be obtained on request to its secretary.

Cross-references

The British Standards which implement international or European publications referred to in this document may be found in the *BSI Catalogue* under the section entitled “International Standards Correspondence Index”, or by using the “Search” facility of the *BSI Electronic Catalogue* or of British Standards Online.

This publication does not purport to include all the necessary provisions of a contract. Users are responsible for its correct application.

Compliance with a British Standard does not of itself confer immunity from legal obligations.

Summary of pages

This document comprises a front cover, an inside front cover, the EN title page, the EN foreword page, the ISO title page, pages ii to v, a blank page, pages 1 to 32, an inside back cover and a back cover.

The BSI copyright notice displayed in this document indicates when the document was last issued.

Amendments issued since publication

| Amd. No. | Date | Comments |
|----------|------|----------|
| | | |
| | | |
| | | |
| | | |

This British Standard was published under the authority of the Standards Policy and Strategy Committee on 17 October 2005

© BSI 17 October 2005

EUROPEAN STANDARD

EN ISO 18856

NORME EUROPÉENNE

EUROPÄISCHE NORM

August 2005

ICS 13.060.50

English Version

Water quality - Determination of selected phthalates using gas chromatography/mass spectrometry (ISO 18856:2004)

Qualité de l'eau - Dosage de certains phtalates par chromatographie en phase gazeuse/spectrométrie de masse (ISO 18856:2004)

Wasserbeschaffenheit - Bestimmung ausgewählter Phthalate mittels Gaschromatographie/Massenspektrometrie (ISO 18856:2004)

This European Standard was approved by CEN on 20 July 2005.

CEN members are bound to comply with the CEN/CENELEC Internal Regulations which stipulate the conditions for giving this European Standard the status of a national standard without any alteration. Up-to-date lists and bibliographical references concerning such national standards may be obtained on application to the Central Secretariat or to any CEN member.

This European Standard exists in three official versions (English, French, German). A version in any other language made by translation under the responsibility of a CEN member into its own language and notified to the Central Secretariat has the same status as the official versions.

CEN members are the national standards bodies of Austria, Belgium, Cyprus, Czech Republic, Denmark, Estonia, Finland, France, Germany, Greece, Hungary, Iceland, Ireland, Italy, Latvia, Lithuania, Luxembourg, Malta, Netherlands, Norway, Poland, Portugal, Slovakia, Slovenia, Spain, Sweden, Switzerland and United Kingdom.



EUROPEAN COMMITTEE FOR STANDARDIZATION
COMITÉ EUROPÉEN DE NORMALISATION
EUROPÄISCHES KOMITEE FÜR NORMUNG

Management Centre: rue de Stassart, 36 B-1050 Brussels

Foreword

The text of ISO 18856:2004 has been prepared by Technical Committee ISO/TC 147 "Water quality" of the International Organization for Standardization (ISO) and has been taken over as EN ISO 18856:2005 by Technical Committee CEN/TC 230 "Water analysis", the secretariat of which is held by DIN.

This European Standard shall be given the status of a national standard, either by publication of an identical text or by endorsement, at the latest by February 2006, and conflicting national standards shall be withdrawn at the latest by February 2006.

According to the CEN/CENELEC Internal Regulations, the national standards organizations of the following countries are bound to implement this European Standard: Austria, Belgium, Cyprus, Czech Republic, Denmark, Estonia, Finland, France, Germany, Greece, Hungary, Iceland, Ireland, Italy, Latvia, Lithuania, Luxembourg, Malta, Netherlands, Norway, Poland, Portugal, Slovakia, Slovenia, Spain, Sweden, Switzerland and United Kingdom.

Endorsement notice

The text of ISO 18856:2004 has been approved by CEN as EN ISO 18856:2005 without any modifications.

INTERNATIONAL
STANDARD

ISO
18856

First edition
2004-09-15

**Water quality — Determination of
selected phthalates using gas
chromatography/mass spectrometry**

*Qualité de l'eau — Dosage de certains phtalates par chromatographie
en phase gazeuse/spectrométrie de masse*



Reference number
ISO 18856:2004(E)

Contents

Page

| | |
|--|----|
| Foreword..... | iv |
| Introduction | v |
| 1 Scope | 1 |
| 2 Normative references | 2 |
| 3 Principle | 2 |
| 4 Interferences | 3 |
| 5 Reagents | 3 |
| 6 Apparatus | 5 |
| 7 Sampling and sample pre-treatment | 7 |
| 8 Procedure | 7 |
| 9 Calibration | 10 |
| 10 Calculation | 13 |
| 11 Expression of results | 15 |
| 12 Precision | 15 |
| 13 Test report | 15 |
| Annex A (informative) List of phthalates | 16 |
| Annex B (informative) General remarks | 18 |
| Annex C (normative) Precision data | 19 |
| Annex D (informative) Examples of solutions (overview) | 22 |
| Annex E (informative) Example of equipment to avoid contaminations | 25 |
| Annex F (informative) Examples of suitable capillary columns | 29 |
| Annex G (informative) Example of gas chromatographic conditions | 30 |
| Bibliography | 32 |

Foreword

ISO (the International Organization for Standardization) is a worldwide federation of national standards bodies (ISO member bodies). The work of preparing International Standards is normally carried out through ISO technical committees. Each member body interested in a subject for which a technical committee has been established has the right to be represented on that committee. International organizations, governmental and non-governmental, in liaison with ISO, also take part in the work. ISO collaborates closely with the International Electrotechnical Commission (IEC) on all matters of electrotechnical standardization.

International Standards are drafted in accordance with the rules given in the ISO/IEC Directives, Part 2.

The main task of technical committees is to prepare International Standards. Draft International Standards adopted by the technical committees are circulated to the member bodies for voting. Publication as an International Standard requires approval by at least 75 % of the member bodies casting a vote.

Attention is drawn to the possibility that some of the elements of this document may be the subject of patent rights. ISO shall not be held responsible for identifying any or all such patent rights.

ISO 18856 was prepared by Technical Committee ISO/TC 147, *Water quality*, Subcommittee SC 2, *Physical, chemical and biochemical methods*.

Introduction

The user should be aware that particular problems could require the specification of additional marginal conditions.

Water quality — Determination of selected phthalates using gas chromatography/mass spectrometry

WARNING — Persons using this International Standard should be familiar with normal laboratory practice. This International Standard does not purport to address all of the safety problems, if any, associated with its use. It is the responsibility of the user to establish appropriate safety and health practices and to ensure compliance with any national regulatory conditions.

IMPORTANT — It is absolutely essential that tests conducted according to this International Standard be carried out by suitably trained staff.

1 Scope

This International Standard specifies a method for the determination of phthalates in water after solid phase extraction and gas chromatography/mass spectrometry.

This method is applicable to the determination of phthalates (see Table 1) in ground water, surface water, wastewater and drinking water in mass concentrations ranging from above 0,02 µg/l up to 0,150 µg/l, depending on the individual substance and the value of the blank.

The applicability of this method to other phthalates not specified in Table 1 is not excluded, but it is necessary to determine its applicability in each case (see Annex A for the list of phthalates).

General remarks concerning the recovery and use of internal standards is given in Annex B.

Table 1 — Phthalates determined by this method

| No | Name | Formula | Abbreviation | Molar mass g/mol | CAS ^a number |
|----|--------------------------------|--|--------------|---------------------|-------------------------|
| 1 | Dimethyl phthalate | C ₁₀ H ₁₀ O ₄ | DMP | 194,2 | 131-11-3 |
| 2 | Diethyl phthalate | C ₁₂ H ₁₄ O ₄ | DEP | 222,24 | 84-66-2 |
| 3 | Dipropyl phthalate | C ₁₄ H ₁₈ O ₄ | DPP | 250,3 | 131-16-8 |
| 4 | Diisobutyl phthalate | C ₁₆ H ₂₂ O ₄ | DiBP | 278,4 | 84-69-5 |
| 5 | Dibutyl phthalate | C ₁₆ H ₂₂ O ₄ | DBP | 278,4 | 84-74-2 |
| 6 | Butyl benzyl phthalate | C ₁₉ H ₂₀ O ₄ | BBzP | 312,4 | 85-68-7 |
| 7 | Dicyclohexyl phthalate | C ₂₀ H ₂₆ O ₄ | DCHP | 330,4 | 84-61-7 |
| 8 | Di(2-ethylhexyl) phthalate | C ₂₄ H ₃₈ O ₄ | DEHP | 390,6 | 117-81-7 |
| 9 | Di(<i>n</i> -octyl) phthalate | C ₂₄ H ₃₈ O ₄ | DOP | 390,6 | 117-84-0 |
| 10 | Didecyl phthalate | C ₂₈ H ₄₆ O ₄ | DDcP | 446,7 | 84-77-5 |
| 11 | Diundecyl phthalate | C ₃₀ H ₅₀ O ₄ | DUP | 474,4 | 3648-20-2 |

^a CAS: Chemical Abstracts System.

2 Normative references

The following referenced documents are indispensable for the application of this document. For dated references, only the edition cited applies. For undated references, the latest edition of the reference document (including any amendments) applies.

ISO 5667-1, *Water quality — Sampling — Part 1: Guidance on the design of sampling programmes*

ISO 5667-2, *Water quality — Sampling — Part 2: Guidance on sampling techniques*

ISO 5667-3, *Water quality — Sampling — Part 3: Guidance on the preservation and handling of water samples*

3 Principle

Extraction of the compounds from the water by solid-phase extraction. Then separation is accomplished using capillary columns by gas chromatography and followed by identification and quantification of the phthalates by mass spectrometry. The principle of this method is outlined in Figure 1.

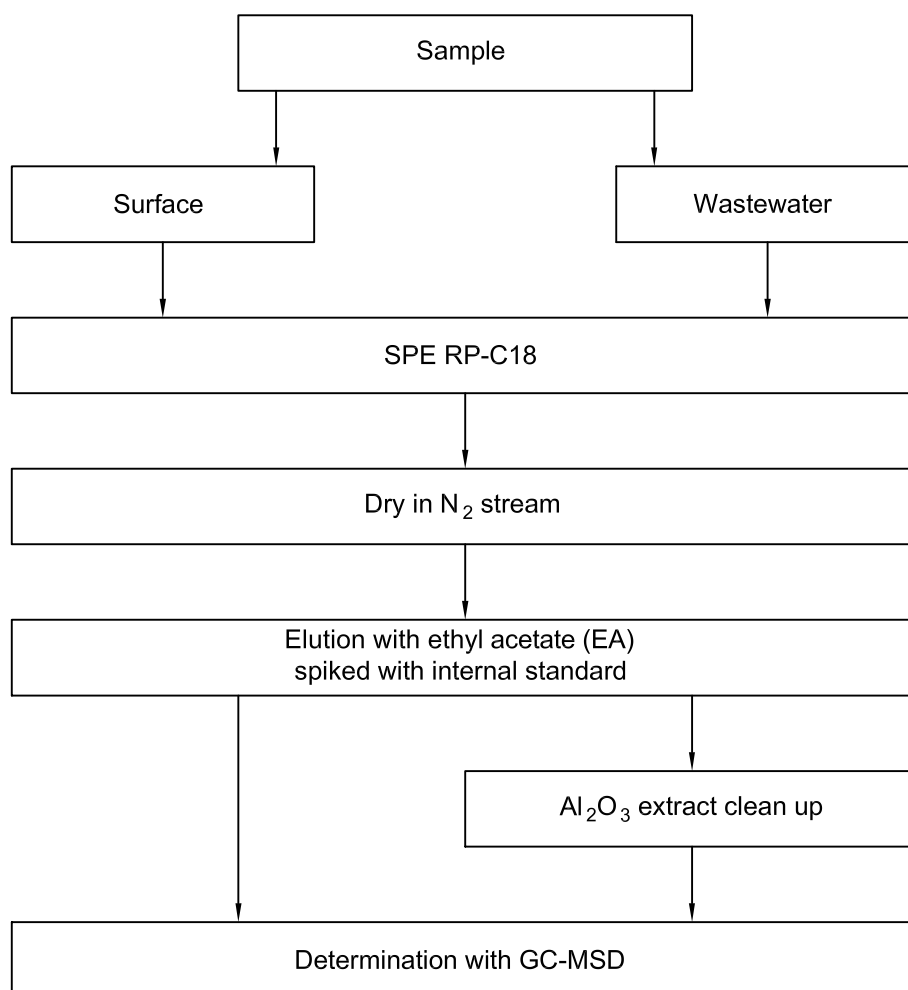

Figure 1 — Flowchart of the analysis

4 Interferences

IMPORTANT — Due to their use as plasticizer agents, phthalates are ubiquitous. Therefore, pay special attention to avoid any contamination.

4.1 Interferences during sampling

In order to avoid interferences and cross-contamination, do not use plastics materials (pipes, etc.).

4.2 Interferences during enrichment

Commercially available adsorbent materials are often of varying quality. Considerable batch-to-batch differences in quality and selectivity of this material are possible. The recovery of single substances may vary with concentration. Therefore, check the recovery regularly at different concentration levels and whenever new batches are used. Perform calibration and analysis with material from the same batch.

Cross-contamination is likely to occur with laboratory air. Therefore, remove, as far as possible, plastics materials from the laboratory. Cleaning agents often contain phthalates and may severely contaminate the laboratory air if in use regularly. Therefore, refrain from using these agents during application of this procedure.

The use of plastics gloves during pre-treatment may increase the contamination.

The maximum allowed blank level for each phthalate is 80 ng/l with reference to water (see Annex C).

4.3 Interferences in gas chromatography

Phthalates may bleed from the septa of the injector into the gas chromatograph, therefore use septa that are not likely to contaminate the system.

Fittings of syringes, for example, or equipment and septa of the sampling bottles (see 6.7) may as well contain phthalates. Therefore make sure that uncontaminated septa are used.

5 Reagents

Use, as far as available, reagents of analytical quality, or better. Use only reagents with negligibly low concentrations of phthalates and verify by blank determinations and, if necessary, apply additional cleaning steps.

5.1 Water, having a negligibly low concentration of phthalates.

In some cases, it may be preferable to use surface water instead of distilled water, because the concentration levels of the blank of surface water can be lower (9.3). Other waters with negligibly low concentrations of phthalates may be used as well.

5.2 Nitrogen, N₂ of high purity, at least a volume fraction of 99,9 %, for drying and eventually for concentration by evaporation.

5.3 Helium, He of high purity, at least a volume fraction of 99,999 %.

5.4 Operating gases for gas chromatography/mass spectrometry, of high purity and in accordance with manufacturer's specifications.

5.5 Ethyl acetate, highest purity, C₄H₈O₂.

5.6 Methanol, CH₃OH.

5.7 Isooctane, C_8H_{18} (2,2,4-trimethylpentane).

5.8 Quartz wool, heated to 400 °C for at least 4 h.

5.9 Reversed-phase C18 (RP-C18) material.

Alternative material and commercial glass cartridges may be used, provided the properties are similar to the material described in this International Standard and the properties are checked in accordance with 4.2.

Check break-through rates prior to starting the analysis and each time a new batch of RP-C18 is used.

5.10 Aluminium oxide, alumina, Al_2O_3 , neutral, 50 μm to 200 μm , heated to 400 °C for at least 4 h.

Bring the aluminium oxide to ambient temperature within 6 h. Store in a covered flask. Use within 5 d after baking.

Alternative materials, such as Florisil¹⁾ or silica may be used, provided their properties and capacity to separate are similar to aluminium oxide and their properties are checked in accordance with 4.2.

5.11 Internal standards, for example diallyl phthalate, DAIP, $C_{14}H_{14}O_4$; D4-ring-deuterated dibutyl phthalate, "D4-DBP", $D_4-C_{16}H_{22}O_4$; D4-ring-deuterated di(*n*-octyl) phthalate, "D4-DOP", $D_4-C_{24}H_{38}O_4$, ¹³C_(6 to 12)-labelled standard (as far as available).

5.12 Reference substances of the phthalates, mentioned in Table 1, with defined mass concentrations, for the preparation of reference solutions for the gas chromatographic procedure.

5.13 Solutions of single substances.

In a 10 ml volumetric flask (6.15), dissolve, for example, 10 mg of each of the reference substances in ethyl acetate (5.5) and bring to volume with ethyl acetate (mass concentration: 1 g/l).

Store the solutions in glass bottles at –18 °C, protected from light, and check the concentration at least every three months.

5.14 Stock solution.

In a 10 ml volumetric flask (6.15), add a volume between 100 μl and 500 μl of the single substance solutions (5.13) and bring to volume with ethyl acetate (mass concentration 10 mg/l to 50 mg/l).

Store the solution in a glass bottle at –18 °C, protected from light, and check the concentration at least every three months.

5.15 Reference solutions for multipoint calibration.

Prepare solutions by adequate dilution of the stock solution (5.14) and internal standards (5.17) with ethyl acetate (5.5).

Store the solutions in a glass bottle at –18 °C, protected from light and check the concentration at least every three weeks.

5.16 Reference solution for the determination of the recovery.

Prepare solutions by adequate dilution of the stock solution (5.14) with ethyl acetate.

1) Florisil is a trade name of prepared magnesium silicate. This information is given for the convenience of users of this International Standard and does not constitute an endorsement by ISO of this product.

5.17 Solution of the internal standards (see Annex D).

5.17.1 Internal standard stock solution of D4-ring-deuterated-di(*n*-octyl) phthalate (D4-ring-DOP).

Weigh for example 0,1 g of D4-DOP (5.11) in a 10 ml volumetric flask (6.15) filled with about 5 ml of ethyl acetate (5.5), and bring to volume with ethyl acetate.

5.17.2 Internal standard stock solution of D4-ring-deuterated-dibutyl phthalate (D4-ring-DBP).

Weigh for example 0,1 g of D4-DBP (5.11) in a 10 ml volumetric flask (6.15) filled with about 5 ml of ethyl acetate (5.5) and bring to volume with ethyl acetate.

5.17.3 Solution I internal standard.

Combine both solutions (5.17.1 and 5.17.2), for example, by dilution 1:100 by pipetting 0,1 ml of each solution into a 10 ml volumetric flask (6.15) filled with about 5 ml of ethyl acetate (5.5). Bring to volume with ethyl acetate.

5.17.4 Solution II internal standard.

From Solution I (5.17.3), for example take 250 μ l and transfer it to a volumetric flask of 250 ml (6.15) and bring to volume with ethyl acetate (5.5).

The final concentrations of D4-DBP and of D4-DOP will be 0,1 mg/l in ethyl acetate.

5.17.5 Solution III internal standard.

Transfer 1 ml of Solution I internal standard (5.17.3) to a 10 ml volumetric flask (6.15), filled with 5 ml of ethyl acetate and bring to volume with ethyl acetate (5.5).

The final concentrations of D4-DBP and of D4-DOP will be 10 mg/l in ethyl acetate.

5.18 Standard solution for the determination of the retention times.

Dilute the solutions of the single substances (5.13) for example 1:1 000 with ethyl acetate (5.5).

NOTE Example of solutions, see Annex D.

6 Apparatus

Equipment or parts likely to come into contact with the water sample or its extract shall be free from phthalates. This may be achieved by thorough cleaning of all glass apparatus (see 8.1). Examples of equipment to avoid contamination are given in Annex E.

6.1 Narrow-neck flat bottomed flasks with glass stoppers, preferably brown glass, of 1 000 ml and 2 000 ml capacities.

6.2 Drying oven, capable of being maintained at a temperature of (105 ± 10) °C.

6.3 Muffle furnace, adjustable for temperatures of up to 400 °C, with a capacity of at least 60 l.

6.4 Vacuum device for solid phase extraction (vacubox, extraction box, see E.4).

- 6.5 Stainless steel cock**, with stainless steel cone or polytetrafluoroethene (PTFE) cock with a Luer²-connection for separate vacuum connection.
- 6.6 Wash bottle**, for example of 5 l capacity.
- 6.7 Sampling vial, glass**, with inert stopper, e.g. septum, lined with PTFE for storage of the extracts, and glass sampling bottles, with inert septum, of 2 ml capacity, for storage of the extracts for GC autosampler operation.
- 6.8 Glass cartridges**, with Luer²-cone and conical joint in accordance with ISO 383, DN 14/23 (see E.1).
- 6.9 Sample reservoir**, column, having an inner diameter of 4 cm, length of about 35 cm, conical joint in accordance with ISO 383, DN 14/23 (e.g. see E.3).
- 6.10 PTFE-frits for cartridges**, of 6 ml capacity.
- 6.11 Disk to cover the sample reservoir**, with an inner diameter of 4,5 cm, and with a circular depression in the range 3,4 cm to 4,5 cm; in the centre of the aluminium disc a hole for the Luer² cone, having a diameter of 0,5 cm (see E.2).
- 6.12 Aluminium foil**, heated to 400 °C.
- 6.13 Stainless steel reservoir**, for storage of smaller glass apparatus.
- 6.14 Measuring cylinders**, of 250 ml and 500 ml capacities.
- 6.15 Volumetric flasks**, of 1 ml, 2 ml, 10 ml, 25 ml and 250 ml capacities.
- 6.16 Pasteur-pipettes**, e.g. 2 ml.
- 6.17 Syringes**, of 2 µl, 5 µl, 10 µl, 50 µl, 100 µl and 500 µl capacities with a maximum permitted error of ± 2 %.
- 6.18 Gas chromatograph (GC)**, with capillary column, temperature-controlled and with mass spectrometric detection.
- 6.19 Fused silica capillary columns**, with non-polar stationary phase (see Annex F); inner diameter ≤ 0,32 mm, length about 30 m, film thickness of 0,10 µm to 0,50 µm.
- Check the quality of the column, for example by injecting the reference solution (5.16) and ensure that the separation is satisfactory.
- 6.20 Glass tubes**, graduated, and with a capacity of 10 ml.
- 6.21 Nitrogen device for drying**.

2) Luer cone is a special conical joint and is the trade name of a commercially available product. This information is given for the convenience of users of this International Standard and does not constitute an endorsement by ISO of this product.

7 Sampling and sample pre-treatment

Collect, preserve and handle samples in accordance with ISO 5667-1, ISO 5667-2 and ISO 5667-3.

Use for sampling pre-treated sampling bottles (6.1 and 8.1) and make sure that the stoppers are pretreated as well.

Fill the bottles almost completely with the sample.

In general, sampling should be carried out using stainless steel containers or glass vessels.

In order to avoid contamination, do not use any plastics material (tubes and other). If plastics parts in the sampling apparatus are unavoidable, flush the apparatus with at least five times the volume of the sample. If applicable, state this step in the test report.

Extract and analyse the sample as soon as possible after sample collection. If storage is unavoidable, store the samples in the dark at 4 °C no longer than 4 d.

In general, samples are examined without pretreatment, i.e. suspended solids are not removed prior to analysis.

Prior to analysis, homogenize the sample.

8 Procedure

8.1 Pretreatment of glass apparatus

Clean all glass apparatus used during analysis in the dishwasher with water and subsequently dry in the oven (6.2) at 105 °C.

Heat the pre-rinsed glass apparatus in the muffle furnace (6.3) using for example the following temperature programme.

Heat to 100 °C at a rate of 2,5 °C/min; then to 250 °C at a rate of 10 °C/min; finally to 400 °C and maintain 75 min isothermally. Subsequently let the apparatus cool to room temperature within 12 h.

NOTE Glassware for volumetric purposes can change its properties due to the heating process.

Close the cooled glass apparatus (bigger vessels) with the respective stoppers or with aluminium foil (6.12). Store smaller glass apparatus in decontaminated (heated) and appropriately closed stainless steel containers (6.13).

In order to avoid losses by adsorption at the walls, rinse the walls with isooctane (5.7) by using Pasteur pipettes (6.16). Discard the solvent.

Let residual solvent evaporate under a fume hood.

Carry out this deactivation of the surface after heating and cooling or immediately prior to use.

8.2 Extraction

8.2.1 Conditioning of the solid phase material and enrichment

Prepare the cartridges as follows and fill them in the given sequence:

- a) place a PTFE frit (6.10) in the cartridge;
- b) add 250 mg of RP-C18 material (5.9);

c) add heated quartz wool (5.8);

Condition and clean RP-C18 material in the cartridges (6.8) as follows:

- rinse with one bed volume of ethyl acetate (5.5);
- dry with nitrogen for about 10 s (5.2);
- rinse the adsorbent material with two bed volumes of methanol (5.6).

Make sure that the adsorbent material does not run dry after rinsing, e.g. by using the stainless steel cocks (6.5).

Connect the conditioned cartridges (6.8) with the deactivated reservoir (6.9 and 8.1).

Transfer 250 ml of the sample into the reservoir (6.9), using a measuring cylinder (6.14). Record the volume of the sample (subscript sam) V_{sam} .

Alternatively weigh the sample directly into the sample reservoir and cover it with the aluminium disc (6.11). Close the hole with a pretreated cartridge to reduce contamination by air.

With the aid of a vacubox (6.4), pass the sample through the cartridge (6.8) at a flow rate of about 2 ml/min to 10 ml/min (about 700 hPa). A wash bottle (6.6) may be connected between the vacubox (6.4) and the vacuum line to collect the sample after passing through the SPE-cartridges and to protect the vacuum line from entering liquids.

Dry the cartridge with nitrogen (5.2 and 6.21) for about 5 min by connecting the cartridges to a second vacubox (6.4), thus leading the nitrogen directly over the cartridge.

After drying, place the glass tubes (6.20) into the vacubox, elute the cartridge with 2 ml of internal standard solution (5.17.4) on the vacubox (6.4) under normal pressure.

After elution of 2 ml, apply a vacuum shortly in order to collect the remaining drops.

The internal standards may be used to eliminate losses by evaporation and injection variations.

Transfer the extract to a GC vial (6.7) and record the volume of extract collected (subscript ex), V_{ex} , to be injected. Wrap heated aluminium foil (6.12) around the septum, so that the foil comes between the septum and the vial, thus avoiding any contamination by phthalates from the septum.

8.2.2 Extract cleaning

In the case of wastewater, clean the extracts as follows:

Place 1 g of activated aluminium oxide, Al_2O_3 (5.10) in the cartridges (6.8) between two PTFE frits (6.10).

Clean the Al_2O_3 (5.10) with one bed volume of ethyl acetate (5.5).

Dry with nitrogen (5.2) for 1 min.

Let the extract run through the cartridge and collect it in a glass tube (6.20).

Transfer the extract to a GC vial (6.7). Wrap heated aluminium foil (6.12) around the septum, so that the foil comes between the septum and the vial, thus avoiding any contamination by phthalates from the septum.

8.3 Gas chromatography

Optimize the GC-apparatus (6.18) according to the instrument manufacturer's manual.

Use capillary columns (6.19; see also Annex G) for separation.

In order to clean the inlet system free from phthalates, inject ethyl acetate (5.5) at least five times from various GC-vials (see Clause 6) before measuring the sample extracts or calibration solutions.

8.4 Blank monitoring

Check the proper condition of instruments and reagents by blank monitoring at regular intervals.

For the blank measurements, treat a cartridge (8.2.1), filled with RP-C18 material, in the same way as the cartridge of the sample (see Clause 7), but stopper the cartridges during absorption. With each sample series determine two blanks.

Further proceed as specified in 8.2.1 to 8.3.

8.5 Identification of individual compounds

8.5.1 General

Individual compounds are identified by comparison of the retention times of the respective peaks in the sample chromatogram with the substance peaks of a reference solution measured under the same conditions.

The compound is classified as not detected if the chromatogram of the sample extract does not contain a peak at the specific retention time corresponding to the substance.

The presence of a distinct compound is classified as possible if a peak occurs at the substance specific retention time. If necessary, the identity of the compound shall be verified by additional investigations.

8.5.2 Identification of individual compounds with mass spectrometric detection

Consider individual compounds in the sample to be identified if:

- the retention time (t_R) of the respective peaks in the total ion-current chromatograms or in the individual mass chromatograms lie within a tolerance of $t_R \pm 0,03$ min, compared with the retention times of the peaks of the substances in the total ion current chromatograms or individual mass chromatograms of a reference solution, measured under identical conditions, and
- the complete, background-corrected mass spectra of the reference compounds agree with the background-corrected mass spectra obtained at the respective retention time in the total ion-current chromatogram of the sample; or
- at least the characteristic molecular ions or fragment ions of the reference compounds (see Table 2) agree with specified tolerances which should not be greater than 20 %, with those of the compounds to be identified as to the relative peak intensities.

Table 2 — Mass fragments of the reference compounds

| No. | Compound | Abbreviation | Specific monitored ions | | |
|-----|--|--------------|-------------------------|--------------------------|--------------------------|
| | | | Target ion M_1^a | Qualifier ion M_2^a | Qualifier ion M_3^a |
| 1 | Dimethyl phthalate | DMP | 163 | 194 | 135 |
| 2 | Diethyl phthalate | DEP | 149 | 177 | 222 |
| 3 | Dipropyl phthalate | DPP | 149 | 209 | 191 |
| 4 | Diisobutyl phthalate | DiBP | 149 | 223 | — |
| 5 | Dibutyl phthalate | DBP | 149 | 223 | 278 |
| 6 | Butyl benzyl phthalate | BBzP | 149 | 206 | 312 |
| 7 | Dicyclohexyl phthalate | DCHP | 149 | 167 | 249 |
| 8 | Di(2-ethylhexyl) phthalate | DEHP | 149 | 167 | 279 |
| 9 | Di(<i>n</i> -octyl) phthalate | DOP | 149 | 279 | 207 |
| 10 | Didecyl phthalate | DDcP | 149 | 307 | — |
| 11 | Diundecyl phthalate | DUP | 149 | 321 | — |
| 12 | D4-ring-dibutyl phthalate | D4-DBP | 153 | — | — |
| 13 | D4-ring-di(<i>n</i> -octyl) phthalate | D4-DOP | 153 | — | — |
| 14 | Diallyl phthalate | DaIP | 149 | 189 | 132 |

^a M_1 is used for quantification, M_2 and M_3 may be used for identification.

9 Calibration

9.1 General

For each compound, establish a calibration function and graph using single, or, for practical reasons, multicomponent reference solutions.

Make sure that the measured-signal-to-concentration relation obtained is linear.

Determine the linear working range by at least five points from five different concentrations.

The calibration function determined for a single component is valid only for the respective concentration range. This function also depends on the operating conditions of the gas chromatograph and needs to be checked regularly. For routine purposes, a two-point calibration is sufficient.

A procedure is given for the setup of a calibration function and the working range is adjusted to the working conditions (preparation of the reference solution according to 5.15).

Calibration of the gas chromatographic step is performed using external standards, not using the overall procedure and including an internal standard.

9.2 Calibration with external standard, not using the overall procedure

Set up a calibration function from at least five reference solutions (5.15), and for practical reasons, determine all phthalates mentioned in Table 1 within one procedure.

The knowledge of the retention times of the single components is a prerequisite. The retention times are determined using the solutions of the single components (5.13).

Inject aliquots from the reference solutions (5.15). Make sure that the injection volume is the same during calibration and measurement of the sample.

For a graphical presentation of the calibration curve, plot the respective measured values $y_{i,\text{std}}$ (peak area, peak height or integration units) for each substance i calibrated (subscript std for external standard calibration), on the ordinate against the respective mass concentration $\rho_{i,\text{std}}$ on the abscissa.

Use the series of measured values thus obtained to establish the linear regression function as follows:

$$y_{i,\text{std}} = a_i \times \rho_{i,\text{std}} + b_i \quad (1)$$

where

$y_{i,\text{std}}$ is the measured value, for example expressed as area value, for the external standard (subscript std) of the substance i in the calibration, depending on $\rho_{i,\text{std}}$, the unit of which depends on the type of evaluation performed;

a_i is the slope, for example expressed as peak area times litre per microgram ($\text{area} \times \text{l}/\mu\text{g}$), of the calibration function of the substance i (corresponds to the substance-specific response factor);

$\rho_{i,\text{std}}$ is the mass concentration, expressed in micrograms of the substance i (external standard in the reference solution) per litre ($\mu\text{g}/\text{l}$);

b_i is the ordinate intercept, for example expressed as area value, of the calibration function of the substance i , the unit of which depends on the type of evaluation performed.

For quantification, second order functions are permissible.

NOTE Calibration with an external standard (overall procedure) is difficult to achieve as water without a blank value is not easily available.

9.3 Determination of the within-laboratory recovery

Reliable recoveries are obtained by determination on different concentration levels, spread evenly over the working range and combination to a mean, substance specific recovery rate η_i .

Spike for example 250 ml of water (surface water is the most suitable) with different volumes of the reference solution (5.16) and proceed exactly in the same way as for the real sample.

In parallel, measure the values in surface water without spiking and determine the recovery from the differences.

Using the calibration procedure given in 9.2, determine the substance specific mean recovery η_i for the substance i using Equations (2) and (3):

$$\bar{\eta}_i = \frac{\sum_{k=1}^N \eta_{i,k}}{N} \quad (2)$$

$$\eta_{i,k} = \frac{\rho_{i,k,\text{rec}}}{\rho_{i,k,\text{def}}} \quad (3)$$

where

- $\bar{\eta}_i$ is the mean recovery of substance i ;
- N is the number of single measurements of $\eta_{i,k}$;
- $\eta_{i,k}$ is the recovery of the substance i at the concentration level k ;
- $\rho_{i,k,\text{rec}}$ is the recovered mass concentration, expressed in nanograms per litre (ng/l), of the substance i at the concentration level k ;
- $\rho_{i,k,\text{def}}$ is the mass concentration, expressed in nanograms per litre (ng/l), of the substance i at the concentration level k .

Low or varying recoveries are an indication of matrix effects and/or of difficulties in the extraction step.

9.4 Calibration with internal standard

When using the internal standard calibration, the determination is independent from possible errors made during injection. Apart from this, errors caused by sample losses during distinct steps of sample pre-treatment may be avoided. Additionally, the concentration determination is independent from matrix effects in the sample, provided the recoveries of the substances analysed and the internal standard are about the same.

The mass concentration of the internal standard, $\rho_{i,\text{is}}$ shall be the same for calibration and sample measurement.

Plot the rational value $y_{i,\text{std}}/y_{i,\text{is}}$ (peak areas, peaks heights or integration units) for each substance i on the ordinate and the associated rational mass concentration $\rho_{i,\text{std}}/\rho_{i,\text{is}}$ on the abscissa.

Establish the linear regression function using the pairs of value $y_{i,\text{std}}/y_{i,\text{is}}$ and $\rho_{i,\text{std}}/\rho_{i,\text{is}}$ of the measured series in the following equation:

$$\frac{y_{i,\text{std}}}{y_{i,\text{is}}} = a_i \frac{\rho_{i,\text{std}}}{\rho_{i,\text{is}}} + b_i \quad (4)$$

where

- $y_{i,\text{std}}$ is the measured value, for example expressed as area values, for the substance i (subscript i) in the calibration (subscript e), depending on $\rho_{i,\text{std}}$, the unit of which depends on the type of evaluation performed;
- $y_{i,\text{is}}$ is the measured value of the internal standard (subscript is) i in the calibration, depending on $\rho_{i,\text{is}}$; the unit depends on the evaluation, for example, area value, for the total procedure;
- $\rho_{i,\text{std}}$ is the (independent variable) mass concentration of the substance i in the calibration solution for the total procedure;
- $\rho_{i,\text{is}}$ is the (independent variable) mass concentration, expressed in micrograms per litre, of the internal standard, in micrograms per litre, for the total procedure;
- a_i is the slope of the calibration curve from $y_{i,\text{std}}/y_{i,\text{is}}$ as a function of the mass concentration ratio $\rho_{i,\text{std}}/\rho_{i,\text{is}}$;
- b_i is the axis intercept of the calibration curve on the ordinate.

10 Calculation

10.1 Calculation of single results

Calculation of single results obtained by calibration with external standard, not including the overall procedure.

Calculate the mass concentration ρ_i of the substance i in the sample according to Equation (5):

$$\rho_i = \frac{(y_i - b_i) V_{\text{ex}} \times f}{\eta_{i,\text{is}} \times V_{\text{sam}}} - \rho_{i,\text{bl}} \quad (5)$$

$$\rho_{i,\text{bl}} = \frac{(y_{i,\text{bl}} - b_i) V_{\text{ex,bl}} \times f}{\eta_{i,\text{is}} \times V_{\text{sam}}} \quad (6)$$

where

ρ_i is the mass concentration, expressed in nanograms per litre (ng/l), of the substance i in the sample;

y_i is the measured value, for example expressed as peak area, of the substance i in the sample;

V_{ex} is the final volume, expressed in millilitres (ml), of the sample extract used for injection (subscript ex), determined in 8.2;

$\eta_{i,\text{is}}$ is the recovery of the internal standards [see Equation (9)]; for the phthalates DMP to DEHP the recovery of the D4-DBP is used for calculation, and for the phthalates DOP to DUP the recoveries are calculated from the D4-DOP;

V_{sam} is the volume, expressed in millilitres (ml), of the extracted water sample (subscript sam), determined according to 8.2.1;

$\rho_{i,\text{bl}}$ is the blank (subscript bl) of the substance i , determined according to 8.4;

$y_{i,\text{bl}}$ is the measured value, for example expressed as peak area, of the substance i in the blank;

$V_{\text{ex,bl}}$ is the volume, expressed in millilitres (ml), of the blank extract used for injections;

f is the conversion factor and for expressing results in nanograms per litre (ng/l), $f = 1\,000$ whereas for expressing results in micrograms per litre ($\mu\text{g/l}$), $f = 1$;

and a_i and b_i are defined in Equation (1).

NOTE For an explanation of the Equations (5) and (6), Equations (7) and (8) can be helpful.

$$\rho_i = \frac{\left[\left(\frac{y_i - b_i}{a_i} \right) V_{\text{ex}} - \left(\frac{y_{i,\text{bl}} - b_i}{a_i} \right) V_{\text{ex,bl}} \right] \times f}{\eta_{i,\text{is}} \times V_{\text{sam}}} \quad (7)$$

where ρ_i , y_i , V_{ex} , $\eta_{i,\text{is}}$, V_{sam} , $y_{i,\text{bl}}$, and $V_{\text{ex,bl}}$ are defined in Equation (5).

If $V_{\text{ex}} = V_{\text{ex,bl}}$, Equation (7) can be simplified to

$$\rho_i = \frac{\left(\frac{y_i - y_{i,\text{bl}}}{a_i} \right) V_{\text{ex}} \times f}{\eta_{i,\text{is}} \times V_{\text{sam}}} \quad (8)$$

10.2 Determination of the recovery of the internal standard

Calculate the recovery of the internal standard, η_{is} , expressed as a percentage, as follows:

$$\eta_{\text{is}} = \frac{y_{\text{is}} \times V_{\text{ex}} \times f}{y_{\text{is,t}} \times V_{\text{el}}} \quad (9)$$

where

y_{is} is the measured value, for example expressed as peak area, of the internal standard in the sample extract;

$y_{\text{is,t}}$ is the theoretical (subscript t) measured value of the internal standard, for example peak area;

V_{ex} is the final volume, expressed in millilitres (ml), of the sample extract used for injection;

f is the conversion factor, i.e. $f = 100$ for expression of results in percent;

V_{el} is the volume, expressed in millilitres (ml), of the solvent used for elution (subscript el).

NOTE 1 The internal standard can be used to eliminate losses by evaporation, elution and injection variations.

NOTE 2 The theoretical measured value refers to the value measured for the internal standard in the blank solution prepared according to 8.4 and 5.17.4.

10.3 Calculation of single results after calibration with internal standard

Calculate the mass concentration, ρ_i , of the substance using Equation (10):

$$\rho_i = \frac{\left(\frac{y_i - b_i}{y_{i,\text{is}}} \right) \frac{a_i}{\rho_{i,\text{is}}} \times V_{\text{ex}} \times f}{V_{\text{sam}}} - \rho_{i,\text{bl}} \quad (10)$$

$$\rho_{i,\text{bl}} = \frac{\left(\frac{y_{i,\text{bl}} - b_i}{y_{i,\text{is}}} \right) \frac{a_i}{\rho_{i,\text{is}}} \times V_{\text{ex,bl}} \times f}{V_{\text{sam}}} \quad (11)$$

where y_i , ρ_i , $\rho_{i,\text{bl}}$, $y_{i,\text{bl}}$, $V_{\text{ex,bl}}$, V_{ex} and V_{sam} are defined in Equation (5) and $y_{i,\text{is}}$, $\rho_{i,\text{is}}$, a_i and b_i are defined in Equation (4).

11 Expression of results

In the case of drinking water, surface water and wastewater, report the results in micrograms per litre ($\mu\text{g/l}$) to two significant digits.

EXAMPLES

| | | |
|--------------------------------|-----------------------|------------|
| Di(<i>n</i> -octyl) phthalate | 0,065 $\mu\text{g/l}$ | (65 ng/l) |
| Dodecyl phthalate | 0,15 $\mu\text{g/l}$ | (150 ng/l) |
| Dimethyl phthalate | 1,2 $\mu\text{g/l}$ | |

12 Precision

Precision results from an interlaboratory trial where tests were carried out on drinking water, surface water and wastewater are given in Annex C. Results show that the maximum allowed blank level for each phthalate is 80 ng/l with reference to water.

13 Test report

The report shall contain the following information:

- a) reference to this International Standard (ISO 18856:2004);
- b) identity of the sample;
- c) applied method;
- d) results as specified in Clause 11;
- e) if applicable, circumstances that may have affected the result.

For internal documentation, information on sample pre-treatment, storage time and conditions should be stated.

Annex A (informative)

List of phthalates

The list given in Table A.1 is an outline on various phthalates. The method may not be applicable to isomeric mixtures of phthalates causing peak patterns in gas chromatography.

Table A.1 — List of phthalates

| No. | Name | Formula | Abbreviation | Molar mass | CAS No. |
|-----|-------------------------------------|--|--------------|------------|------------|
| 1 | Butyl butoxyethyl phthalate | C ₁₈ H ₂₆ O ₅ | BboEP | 322,4 | 33374-28-6 |
| 2 | Butyl cyclohexyl phthalate | C ₁₈ H ₂₄ O ₄ | BCHP | 304,4 | 84-64-0 |
| 3 | Butyl 2-butoxy-2-exoethyl phthalate | C ₁₈ H ₂₄ O ₆ | BboOeP | 336,4 | 85-70-1 |
| 4 | Butyl decyl phthalate | C ₂₂ H ₃₄ O ₄ | BDcP | 362,6 | 89-19-0 |
| 5 | Butyl benzyl phthalate | C ₁₉ H ₂₀ O ₄ | BBzP | 312,4 | 85-68-7 |
| 6 | Butyl 2-ethylhexyl phthalate | C ₂₀ H ₃₀ O ₄ | BEHP | 334,5 | 85-69-8 |
| 7 | Butyl 8-methylnonyl phthalate | C ₂₂ H ₃₄ O ₄ | BMNP | 362,6 | 89-18-9 |
| 8 | Benzyl 2-ethylhexyl phthalate | C ₂₃ H ₂₈ O ₄ | BzEHP | 368,6 | 18750-05-5 |
| 9 | Butyl-2-methylpropylphthalate | C ₁₆ H ₂₂ O ₄ | BMPP | 278,4 | 17851-53-5 |
| 10 | Diallyl phthalate | C ₁₄ H ₁₄ O ₄ | DalP | 246,3 | 131-17-9 |
| 11 | Butyl octyl phthalate | C ₂₀ H ₃₀ O ₄ | BOP | 334,5 | 84-78-6 |
| 12 | Di(2-butoxyethyl) phthalate | C ₂₀ H ₃₀ O ₆ | DboEP | 366,5 | 117-83-9 |
| 13 | Dibutyl phthalate | C ₁₆ H ₂₂ O ₄ | DBP | 278,4 | 84-74-2 |
| 14 | Dicyclopentyl phthalate | C ₁₈ H ₂₂ O ₄ | DCPeP | 302,4 | 18699-38-2 |
| 15 | Dibenzyl phthalate | C ₂₂ H ₁₈ O ₄ | DBzP | 346,3 | 523-31-9 |
| 16 | Didecyl phthalate | C ₂₈ H ₄₆ O ₄ | DDcP | 446,7 | 84-77-5 |
| 17 | Dicyclohexyl phthalate | C ₂₀ H ₂₆ O ₄ | DCHP | 330,4 | 84-61-7 |
| 18 | Didodecyl phthalate | C ₃₂ H ₅₄ O ₄ | DDdP | 502,8 | 2438-90-8 |
| 19 | Di(2-ethylbutyl) phthalate | C ₂₀ H ₃₀ O ₄ | DEBP | 334,5 | 7299-89-0 |
| 20 | Diethyl phthalate | C ₁₂ H ₁₄ O ₄ | DEP | 222,4 | 84-66-2 |
| 21 | Di(2-ethylhexyl) phthalate | C ₂₄ H ₃₈ O ₄ | DEHP | 390,6 | 117-81-7 |
| 22 | Dihexyl phthalate | C ₂₀ H ₃₀ O ₄ | DHP | 334,5 | 84-75-3 |
| 23 | Di(2-ethoxyethyl) phthalate | C ₁₆ H ₂₂ O ₆ | DeoEP | 310,4 | 605-54-9 |
| 24 | Diheptyl phthalate | C ₂₂ H ₃₄ O ₄ | DHpP | 362,5 | 3648-21-3 |
| 25 | Di(3-methylbutyl) phthalate | C ₁₈ H ₂₆ O ₄ | DMBP | 306,4 | 605-50-5 |
| 26 | Di(1-methylethyl) phthalate | C ₁₄ H ₁₈ O ₄ | DMEP | 250,3 | 605-45-8 |
| 27 | Dimethyl cyclohexyl phthalate | C ₂₂ H ₃₀ O ₄ | DMCHP | 358,5 | 27987-25-3 |
| 28 | Di(5-methylhexyl) phthalate | C ₂₂ H ₃₄ O ₄ | DMHP | 362,5 | 41451-28-9 |
| 29 | Di(11-methyldodecyl) phthalate | C ₃₄ H ₅₈ O ₄ | DMDdP | 530,8 | 27253-26-5 |
| 30 | Di(6-methylheptyl) phthalate | C ₂₄ H ₃₈ O ₄ | DMHpP | 390,6 | 131-15-7 |

Table A.1 (continued)

| No. | Name | Formula | Abbreviation | Molar mass | CAS No. |
|-----|--|--|--------------|------------|------------|
| 31 | Di(8-methylnonyl) phthalate | C ₂₈ H ₄₆ O ₄ | DMNP | 446,7 | 89-16-17 |
| 32 | Dimethyl phthalate | C ₁₀ H ₁₀ O ₄ | DMP | 194,2 | 131-11-3 |
| 33 | Di(2-methoxyethyl) phthalate | C ₁₄ H ₁₈ O ₆ | DmoEP | 282,3 | 117-82-8 |
| 34 | Di(4-methylpentyl) phthalate | C ₂₀ H ₃₀ O ₄ | DMPeP | 334,5 | 146-50-9 |
| 35 | Di(7-methyloctyl) phthalate | C ₂₆ H ₄₂ O ₄ | DMOP | 418,6 | 28553-12-0 |
| 36 | Diisobutyl phthalate | C ₁₆ H ₂₂ O ₄ | DMPP (DiBP) | 278,4 | 84-69-5 |
| 37 | Dinonyl phthalate | C ₂₆ H ₄₂ O ₄ | DNP | 418,6 | 84-76-4 |
| 38 | Diphenyl phthalate | C ₂₀ H ₁₄ O ₄ | DPhP | 318,3 | 84-62-8 |
| 39 | Di(<i>n</i> -octyl) phthalate | C ₂₄ H ₃₈ O ₄ | DOP | 390,6 | 117-84-0 |
| 40 | Dipropyl phthalate | C ₁₄ H ₁₈ O ₄ | DPP | 250,3 | 131-16-8 |
| 41 | Dipentyl phthalate | C ₁₈ H ₂₆ O ₄ | DpeP | 306,4 | 131-18-0 |
| 42 | Ditridecyl phthalate | C ₃₄ H ₅₈ O ₄ | DTdP | 530,9 | 119-06-2 |
| 43 | Di(3,3,5-trimethylhexyl) phthalate | C ₂₆ H ₄₂ O ₄ | DTMHP | 418,6 | 4628-60-8 |
| 44 | 2-Ethylhexyl-8-methylnonylphthalate | C ₂₆ H ₄₂ O ₄ | EHMNP | 418,6 | 89-13-4 |
| 45 | Diundecyl phthalate | C ₃₀ H ₅₀ O ₄ | DUP | 474,7 | 3648-20-2 |
| 46 | Methyl 2-ethoxy-2-oxoethyl phthalate | C ₁₃ H ₁₄ O ₆ | MeoOeP | 266,3 | 85-71-2 |
| 47 | Ethyl 2-ethoxy-2-oxoethyl phthalate | C ₁₄ H ₁₆ O ₆ | EeoOeP | 280,3 | 84-72-0 |
| 48 | Hexyl decyl phthalate | C ₂₄ H ₃₈ O ₄ | HDcP | 390,6 | 25724-58-7 |
| 49 | Hexyl 8-methylnonyl phthalate | C ₂₄ H ₃₈ O ₄ | HMNP | 390,6 | 61702-81-6 |
| 50 | Methyl methoxyoxoethyl phthalate | C ₁₂ H ₁₂ O ₆ | MmoOeP | 252,2 | 53161-30-1 |
| 51 | Methyl butyl phthalate | C ₁₃ H ₁₆ O ₄ | MBP | 236,2 | 34006-76-3 |
| 52 | Octyl decyl phthalate | C ₂₆ H ₂₆ O ₄ | OdcP | 418,6 | 119-07-3 |
| 53 | 6-Methylheptyl 8-methylnonyl phthalate | C ₂₆ H ₄₂ O ₄ | MHpMNP | 418,6 | 119-05-1 |
| 54 | Octyl 8-methylnonyl phthalate | C ₂₆ H ₄₂ O ₄ | OMNP | 418,6 | 1330-96-7 |
| 55 | Monobutyl phthalate | C ₁₂ H ₁₄ O ₄ | SBP | 222,2 | 131-70-4 |
| 56 | Monomethyl phthalate | C ₉ H ₈ O ₄ | SMP | 180,2 | 4376-18-5 |
| 57 | Mono(2-ethylhexyl) phthalate | C ₁₆ H ₂₂ O ₄ | SEHP | 278,4 | 4376-20-9 |
| 58 | Monopentyl phthalate | C ₁₃ H ₁₆ O ₄ | SpeP | 236,2 | 24539-56-8 |
| 59 | Monoethyl phthalate | C ₁₀ H ₁₀ O ₄ | SEP | 194,2 | 2306-33-4 |

Annex B (informative)

General remarks

By experience, the recovery rate for phthalates (from DMP to DEHP) is between 75 % and 110 %. The recovery for phthalates from DOP to DUP is in the range from 60 % to 75 %.

In the case of dibutyl phthalate and di(2-ethylhexyl) phthalate, high blanks are likely.

If the internal standard is added to the sample before sample preparation, make sure which blanks are due to the internal standard and the addition technique. In this case, use the calibration with the internal standard. Make sure that there are no adsorption effects of the internal standard on the glassware while storing the sample. Pay attention to any modifications that can result from adding the internal standard before sample preparation to the described method. The elution described in 8.2.1 is made only with ethyl acetate (5.5).

Annex C (normative)

Precision data

An interlaboratory trial, carried out in Germany in spring 2003 with participants from three different countries, resulted in the values given in Tables C.1 to C.3.

Table C.1 — Precision data for drinking water

| Compound | l | n | o | | | $\bar{\bar{x}}$ ng/l | x_{true} ng/l | η % | s_R ng/l | CV_R % | s_r ng/l | CV_r % |
|---|-----|-----|--------|--------|--------|-------------------------|---------------------------|-------------|---------------|-------------|---------------|-------------|
| | | | Type A | Type B | Type C | | | | | | | |
| Dimethyl phthalate | 7 | 24 | 2 | 1 | 0 | 40,7 | 35 | 116,1 | 3,94 | 9,69 | 2,72 | 6,68 |
| Diethyl phthalate | 5 | 20 | 0 | 1 | 2 | 108,5 | 100 | 108,5 | 22,52 | 20,77 | 7,78 | 7,17 |
| Dipropyl phthalate | 6 | 22 | 0 | 1 | 1 | 63,1 | 60 | 105,2 | 7,29 | 11,55 | 6,24 | 9,89 |
| Diisobutyl phthalate | 6 | 22 | 0 | 0 | 0 | 69,9 | 60 | 116,4 | 22,38 | 32,03 | 17,69 | 25,32 |
| Dibutyl phthalate | 8 | 30 | 0 | 0 | 0 | 142,9 | 80 | 178,7 | 167,3 | 117,1 | 147,1 | 102,9 |
| <i>Dibutyl phthalate^a</i> | 5 | 24 | 0 | 0 | 0 | 83,8 | 80 | 104,8 | 31,05 | 37,05 | 31,65 | 37,77 |
| Butyl benzyl phthalate | 7 | 24 | 0 | 0 | 1 | 102,9 | 120 | 85,8 | 46,25 | 44,93 | 11,35 | 11,02 |
| Dicyclohexyl phthalate | 6 | 24 | 0 | 1 | 0 | 79,4 | 75 | 105,8 | 50,61 | 63,77 | 8,10 | 10,20 |
| <i>Dicyclohexyl phthalate^a</i> | 5 | 19 | 1 | 0 | 0 | 58,8 | 75 | 78,4 | 24,85 | 42,24 | 5,06 | 8,59 |
| Di(2-ethylhexyl) phthalate | 6 | 21 | 0 | 0 | 0 | 168,0 | 80 | 210,0 | 148,65 | 88,48 | 67,81 | 40,36 |

Explanation of symbols:

| | |
|-------------------|--|
| l | is the number of laboratories |
| n | is the number of values |
| o | is the type of the outlier, i.e. Type A, B, or C |
| $\bar{\bar{x}}$ | is the total mean |
| x_{true} | is the true value |
| η | is the recovery rate |
| s_R | is the reproducibility standard deviation |
| CV_R | is the reproducibility variation coefficient |
| s_r | is the repeatability standard deviation |
| CV_r | is the repeatability variation coefficient |

^a In the case of drinking and surface water, additional calculations were made, whilst evidential and visual outliers were not taken into account. These results are presented in italics.

Table C.2 — Precision data for surface water

| Compound | <i>l</i> | <i>n</i> | <i>o</i> | | | \bar{x} ng/l | x_{true} ng/l | η % | s_R ng/l | CV_R % | s_r ng/l | CV_r % |
|---|----------|----------|----------|--------|--------|-------------------|---------------------------|-------------|---------------|-------------|---------------|-------------|
| | | | Type A | Type B | Type C | | | | | | | |
| Dimethyl phthalate | 7 | 26 | 0 | 1 | 0 | 1 002 | 1 000 | 100,2 | 143,0 | 14,28 | 82,98 | 8,28 |
| Diethyl phthalate | 7 | 25 | 0 | 0 | 1 | 92 | 70 | 131,4 | 42,3 | 45,97 | 18,78 | 20,41 |
| Dipropyl phthalate | 7 | 26 | 0 | 1 | 0 | 732 | 700 | 104,6 | 99,1 | 13,53 | 52,49 | 7,17 |
| Diisobutyl phthalate | 8 | 29 | 0 | 0 | 0 | 343 | 300 | 114,2 | 138,8 | 40,50 | 50,77 | 14,82 |
| <i>Diisobutyl phthalate^a</i> | 6 | 23 | 0 | 0 | 0 | 303 | 300 | 101,0 | 98,09 | 32,38 | 34,58 | 11,42 |
| Dibutyl phthalate | 7 | 27 | 0 | 0 | 1 | 345 | 250 | 138,1 | 145,7 | 42,19 | 46,71 | 13,52 |
| <i>Dibutyl phthalate^a</i> | 5 | 18 | 1 | 0 | 0 | 262 | 250 | 104,8 | 72,19 | 27,56 | 47,32 | 18,07 |
| Butyl benzyl phthalate | 8 | 30 | 0 | 0 | 0 | 1 688 | 1 500 | 112,5 | 539,4 | 31,95 | 157,93 | 9,36 |
| Dicyclohexyl phthalate | 5 | 20 | 0 | 1 | 1 | 496 | 500 | 99,2 | 176,3 | 35,56 | 29,82 | 6,02 |
| Di(2-ethylhexyl) phthalate | 7 | 28 | 0 | 0 | 0 | 373 | 350 | 106,5 | 257,4 | 69,03 | 83,47 | 22,38 |
| Di(<i>n</i> -octyl) phthalate | 7 | 26 | 0 | 1 | 0 | 714 | 900 | 79,3 | 449,3 | 62,92 | 55,29 | 7,74 |
| Didecyl phthalate | 5 | 19 | 0 | 0 | 0 | 303 | 100 | 303,4 | 221,3 | 72,94 | 16,25 | 5,36 |
| Diundecyl phthalate | 5 | 17 | 0 | 0 | 1 | 158 | 100 | 158,2 | 163,1 | 103,11 | 7,85 | 4,96 |

See Table C.1 for the explanation of symbols.

^a In the case of drinking and surface water, additional calculations were made, whilst evidential and visual outliers were not taken into account. These results are presented in italics.

Table C.3 — Precision data for wastewater

| Compound | <i>l</i> | <i>n</i> | <i>o</i> | | | \bar{x} ng/l | x_{true} ng/l | η % | s_R ng/l | CV_R % | s_r ng/l | CV_r % |
|--------------------------------|----------|----------|----------|--------|--------|-------------------|---------------------------|-------------|---------------|-------------|---------------|-------------|
| | | | Type A | Type B | Type C | | | | | | | |
| Dimethyl phthalate | 7 | 23 | 2 | 0 | 1 | 164,5 | 200 | 82,2 | 34,9 | 21,23 | 12,30 | 7,48 |
| Diethyl phthalate | 8 | 29 | 0 | 0 | 0 | 768,2 | 800 | 96,0 | 192,1 | 25,00 | 72,52 | 9,44 |
| Dipropyl phthalate | 6 | 21 | 0 | 0 | 2 | 2 933,8 | 3 000 | 97,8 | 531,4 | 18,11 | 118,27 | 4,03 |
| Diisobutyl phthalate | 6 | 21 | 0 | 0 | 2 | 978,0 | 1 200 | 81,5 | 283,4 | 28,97 | 70,78 | 7,24 |
| Dibutyl phthalate | 8 | 29 | 0 | 0 | 0 | 924,0 | 1 000 | 92,4 | 263,0 | 28,46 | 166,43 | 18,01 |
| Butyl benzyl phthalate | 7 | 25 | 0 | 0 | 1 | 354,3 | 400 | 88,6 | 69,5 | 19,62 | 27,88 | 7,87 |
| Dicyclohexyl phthalate | 7 | 27 | 0 | 0 | 0 | 1 995,0 | 1 800 | 110,8 | 609,8 | 30,57 | 334,05 | 16,74 |
| Di(2-ethylhexyl) phthalate | 6 | 23 | 0 | 0 | 1 | 859,1 | 1200 | 71,6 | 268,5 | 31,26 | 121,83 | 14,18 |
| Di(<i>n</i> -octyl) phthalate | 6 | 23 | 0 | 0 | 0 | 79,1 | 80 | 98,9 | 56,4 | 71,33 | 12,33 | 15,59 |
| Didecyl phthalate | 5 | 20 | 0 | 0 | 0 | 268,7 | 200 | 134,3 | 230,6 | 85,83 | 22,54 | 8,39 |
| Diundecyl phthalate | 7 | 24 | 0 | 0 | 0 | 225,2 | 200 | 112,6 | 175,0 | 77,71 | 72,15 | 32,04 |

See Table C.1 for the explanation of symbols.

In the interlaboratory trial, samples were spiked by the interlaboratory participants, because of the possible loss of phthalates due to the biological degradability of the phthalates during transport and storage. The phthalate concentration of the unspiked water had to be analysed as well. It was obvious that several laboratories had blank problems. This is the reason for high reproducibility variation coefficients. The reproducibility variation coefficients of dimethyl phthalate and dipropyl phthalate are low in all concentrations and in all matrices, because these are the parameters with the lowest blank problem.

For long-chained phthalates (DDCP and DUP), the spiked concentrations were very low and close to the detection limit because in real waters, the presence of these phthalates is unlikely in higher concentrations. The reproducibility variation coefficient (CV_R) for both of these compounds is therefore quite high.

The interlaboratory trial has shown that the maximum blank level of 80 ng/l water per phthalate should not be exceeded.

Annex D (informative)

Examples of solutions (overview)

Table D.1 — Solutions of the internal standards

| Solution | Subclause | Preparation | Concentration in ethyl acetate |
|--|-----------|---|--|
| Internal standard stock solution of D4-DOP | 5.17.1. | Weigh 0,1 g of D4-DOP in 10 ml ethyl acetate (5.5) | $\rho = 10 \text{ g/l}$ |
| Internal standard stock solution of D4-DBP | 5.17.2 | Weigh 0,1 g of D4-DBP in 10 ml ethyl acetate (5.5) | $\rho = 10 \text{ g/l}$ |
| Solution I internal standard | 5.17.3 | Transfer 0,1 ml of stock solution D4-DOP (5.17.1) and 0,1 ml of the stock solution D4-DBP (5.17.2) to a 10 ml volumetric flask (6.15), filled with 5 ml of ethyl acetate and bring to volume of 10 ml with ethyl acetate (5.5). | $\rho_{\text{D4-DOP}} = 100 \text{ mg/l}$ $\rho_{\text{D4-DBP}} = 100 \text{ mg/l}$ |
| Solution II internal standard | 5.17.4 | (Dilution 1:1 000 of Solution I internal standard) Transfer 250 μl of Solution I internal standard to a 250 ml volumetric flask (6.15), filled with approximately 200 ml ethyl acetate and bring to volume with ethyl acetate (5.5) | $\rho_{\text{D4-DOP}} = 100 \text{ }\mu\text{g/l}$ $\rho_{\text{D4-DBP}} = 100 \text{ }\mu\text{g/l}$ |
| Solution III internal standard | 5.17.5 | (Dilution 1:10 of the Solution I internal standard) Transfer 1 ml of the Solution I internal standard to a 10 ml volumetric flask (6.15), filled with 5 ml of ethyl acetate and bring to volume with ethyl acetate (5.5). | $\rho_{\text{D4-DOP}} = 10 \text{ mg/l}$ $\rho_{\text{D4-DBP}} = 10 \text{ mg/l}$ |

In a 10 ml volumetric flask (6.15), dissolve for example 10 mg of each reference substance (5.12) separately in ethyl acetate (5.5) and bring to volume with ethyl acetate to obtain the solutions given in Table D.2.

Table D.2 — Solution of the single phthalates (5.13)

| Phthalate solutions of the single phthalates | Mass of the single phthalates in 10 ml ethyl acetate | Concentration of each single phthalate in ethyl acetate |
|--|---|--|
| | mg | g/l |
| DMP | 10 | 1 |
| DEP | 10 | 1 |
| DPP | 10 | 1 |
| DiBP | 10 | 1 |
| DBP | 10 | 1 |
| BBzP | 10 | 1 |
| DCHP | 10 | 1 |
| DEHP | 10 | 1 |
| DOP | 10 | 1 |
| DDcP | 10 | 1 |
| DUP | 10 | 1 |

In a 10 ml volumetric flask (6.15) dissolve between 100 µl and 500 µl of the single solutions (5.13) in ethyl acetate (5.5) and bring to volume with ethyl acetate (5.5) to obtain the solutions given in Table D.3.

Table D.3 — Preparation of stock solution (5.14) for multipoint calibration (5.15)

| Phthalate solutions of the single phthalates | Volume of the single phthalates solutions (5.13) | Concentration of each phthalate in ethyl acetate |
|---|---|---|
| | µl | mg/l |
| DMP | 100 | 10 |
| DEP | 100 | 10 |
| DPP | 100 | 10 |
| DiBP | 100 | 10 |
| DBP | 100 | 10 |
| BBzP | 200 | 20 |
| DCHP | 100 | 10 |
| DEHP | 100 | 10 |
| DOP | 200 | 20 |
| DDcP | 500 | 50 |
| DUP | 500 | 50 |

Prepare solutions by adequate dilution of the stock solution (5.14) and the Solution III internal standard (5.17.5) in a 10 ml volumetric flask (6.15) and bring to volume with ethyl acetate (5.5) to obtain the solutions given in Table D.4.

Table D.4 — Preparation of reference solutions for multipoint calibration (5.15)

| Level | Volume stock solution (5.14) µl | Volume Solution III internal standard (5.17.5) µl |
|-------|---------------------------------------|---|
| L1 | 2,5 | 100 |
| L2 | 5 | 100 |
| L3 | 10 | 100 |
| L4 | 20 | 100 |
| L5 | 40 | 100 |
| L6 | 50 | 100 |
| L7 | 100 | 100 |
| L8 | 150 | 100 |
| L9 | 300 | 100 |
| L10 | 450 | 100 |

The concentrations obtained for L1 to L10 are given in Table D.5.

Table D.5 — Concentrations of reference solutions for multipoint calibration (5.15)

| Phthalate | L1 pg/µl | L2 pg/µl | L3 pg/µl | L4 pg/µl | L5 pg/µl | L6 pg/µl | L7 pg/µl | L8 pg/µl | L9 pg/µl | L10 pg/µl |
|-----------|-------------|-------------|-------------|-------------|-------------|-------------|-------------|-------------|-------------|--------------|
| DMP | 2,5 | 5,0 | 10 | 20 | 40 | 50 | 100 | 150 | 300 | 450 |
| DEP | 2,5 | 5,0 | 10 | 20 | 40 | 50 | 100 | 150 | 300 | 450 |
| DPP | 2,5 | 5,0 | 10 | 20 | 40 | 50 | 100 | 150 | 300 | 450 |
| DiBP | 2,5 | 5,0 | 10 | 20 | 40 | 50 | 100 | 150 | 300 | 450 |
| DBP | 2,5 | 5,0 | 10 | 20 | 40 | 50 | 100 | 150 | 300 | 450 |
| BBzP | 5,0 | 10,0 | 20 | 40 | 80 | 100 | 200 | 300 | 600 | 900 |
| DCHP | 2,5 | 5,0 | 10 | 20 | 40 | 50 | 100 | 150 | 300 | 450 |
| DEHP | 2,5 | 5,0 | 10 | 20 | 40 | 50 | 100 | 150 | 300 | 450 |
| DOP | 5,0 | 10,0 | 20 | 40 | 80 | 100 | 200 | 300 | 600 | 900 |
| DDcP | 12,5 | 25,0 | 50 | 100 | 200 | 250 | 500 | 750 | 1 500 | 2 250 |
| DUP | 12,5 | 25,0 | 50 | 100 | 200 | 250 | 500 | 750 | 1 500 | 2 250 |
| D4-DBP | 100 | 100 | 100 | 100 | 100 | 100 | 100 | 100 | 100 | 100 |
| D4-DOP | 100 | 100 | 100 | 100 | 100 | 100 | 100 | 100 | 100 | 100 |

Annex E
(informative)

Example of equipment to avoid contaminations

Dimensions in millimetres

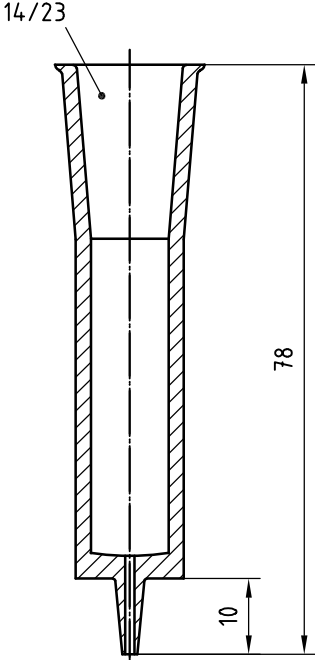

Figure E.1 — Glass cartridge with conical joint (Luer cone)

Dimensions in millimetres

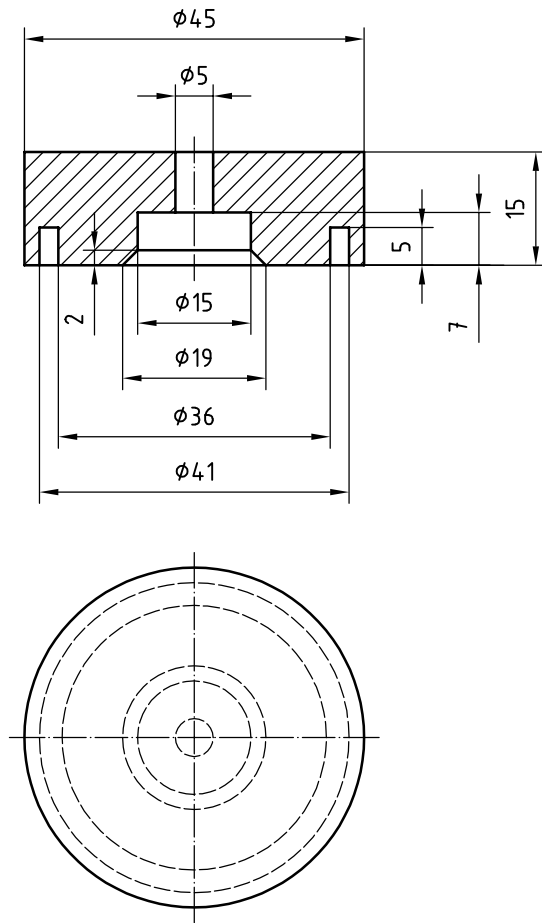
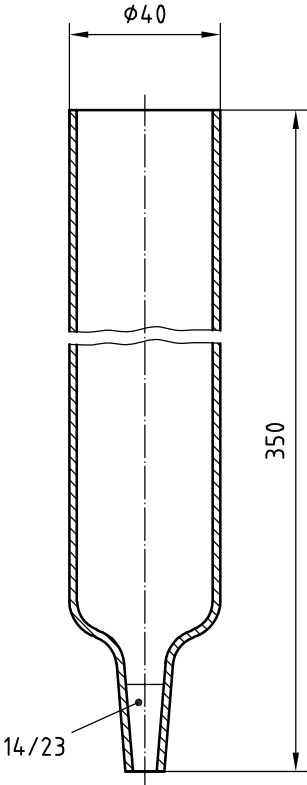

Figure E.2 — Disk

Dimensions in millimetres



- Key**
1 glass cartridge

Figure E.3 — Sample reservoir

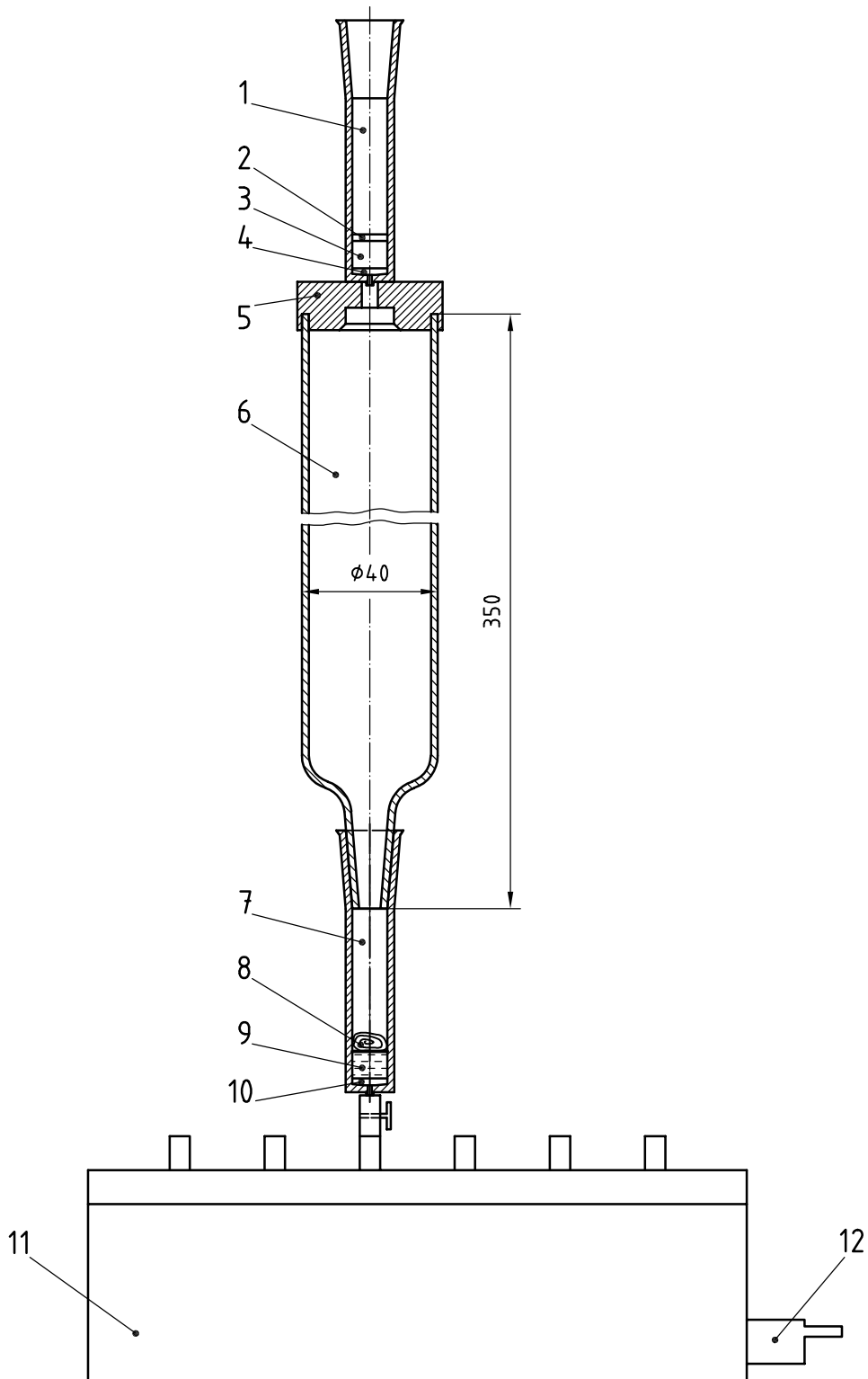

Key

- | | |
|---|---------------------|
| 1 glass cartridge to avoid contaminations | 7 glass cartridge |
| 2 PTFE-frit | 8 quartz wool |
| 3 RP-C18 material | 9 RP-C18 material |
| 4 PTFE-frit | 10 PTFE-frit |
| 5 disk | 11 extraction box |
| 6 sample reservoir | 12 vacuum connector |

Figure E.4 — Complete apparatus

Annex F (informative)

Examples of suitable capillary columns

EXAMPLE 1

Phase: 5 % phenyl methyl siloxane

Dimensions: length: 30 m

inner diameter: 0,25 mm

film thickness: 0,25 μm

EXAMPLE 2

Phase: 34 %/64 %/2 %: phenyl-/methyl-/vinyl-silicone

Dimensions: length: 30 m

inner diameter: 0,32 mm

film thickness: 0,25 μm

Annex G (informative)

Example of gas chromatographic conditions

| | |
|-------------------------------------|--|
| Gas chromatograph (GC): | HP 6890 ³⁾ Series with autosampler HP 6890 series |
| Detector: | quadrupolar mass spectrometric detector |
| Column | HP-5MS ⁴⁾ |
| | length: 30 m |
| | inner diameter: 0,25 mm |
| | film thickness: 0,25 µm |
| Carrier gas: | Helium > 99,999 % purity |
| | pressure: 4,5 bar |
| Injector: | Pulsed splitless; |
| | split: 20 ml/min |
| | splitless period: 1,5 min |
| Injector temperature: | 250 °C |
| Detector temperature: | 290 °C |
| Injection volume: | 1 µl (automatic) |
| Temperature programme: | 70 °C, 3 min isotherm, 13 °C/min to 280 °C, 20 min isotherm |
| Source temperature: | 230 °C |
| Ionization mode: | EI |
| Concentration of standard solution: | between 25 pg/µl and 190 pg/µl |

3) HP 6890 is the trade name of a GC supplied by Hewlett Packard. This information is given for the convenience of users of this International Standard and does not constitute an endorsement by ISO of the product named. Equivalent products may be used if they can be shown to lead to the same results.

4) HP-5MS is the trade name of a column supplied by Hewlett Packard. This information is given for the convenience of users of this International Standard and does not constitute an endorsement by ISO of the product named. Equivalent products may be used if they can be shown to lead to the same results.

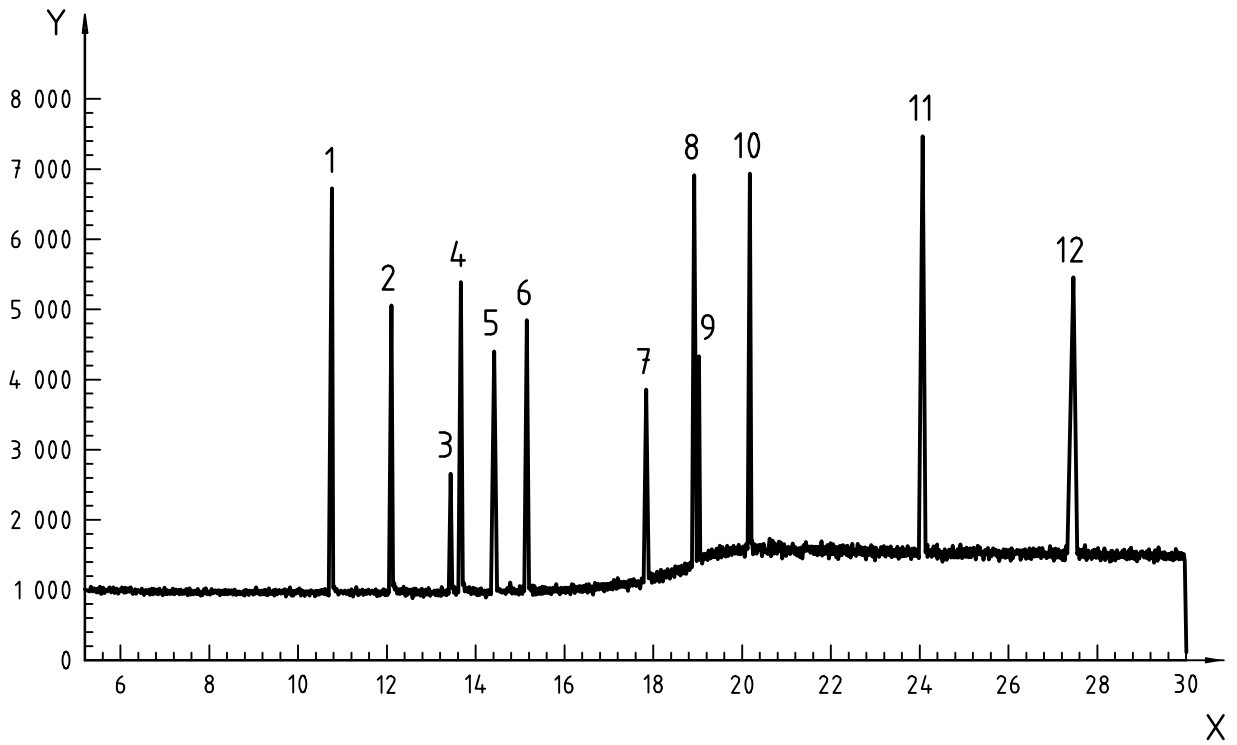
**Key**

X time (min)

Y abundance

1 dimethyl phthalate

2 diethyl phthalate

3 diallyl phthalate

4 dipropyl phthalate

5 di(2-methylpropyl) phthalate

6 dibutyl phthalate

7 butyl benzyl phthalate

8 dicyclohexyl phthalate

9 di(2-ethylhexyl) phthalate

10 di(*n*-octyl) phthalate

11 didecyl phthalate

12 diundecyl phthalate

Figure G.1 — Chromatogram

Bibliography

- [1] FURTMANN, K. Phthalates in surface water — a method for routine trace level analysis. *Fresenius J. Anal. Chem.*, **348**, 1994, pp. 291-296
- [2] ISO 8466-1:1990, *Water quality — Calibration and evaluation of analytical methods and estimation of performance characteristics — Part 1: Statistical evaluation of the linear calibration function*
- [3] ISO 383:1976, *Laboratory glassware — Interchangeable conical ground joints*

BSI — British Standards Institution

BSI is the independent national body responsible for preparing British Standards. It presents the UK view on standards in Europe and at the international level. It is incorporated by Royal Charter.

Revisions

British Standards are updated by amendment or revision. Users of British Standards should make sure that they possess the latest amendments or editions.

It is the constant aim of BSI to improve the quality of our products and services. We would be grateful if anyone finding an inaccuracy or ambiguity while using this British Standard would inform the Secretary of the technical committee responsible, the identity of which can be found on the inside front cover.
Tel: +44 (0)20 8996 9000. Fax: +44 (0)20 8996 7400.

BSI offers members an individual updating service called PLUS which ensures that subscribers automatically receive the latest editions of standards.

Buying standards

Orders for all BSI, international and foreign standards publications should be addressed to Customer Services. Tel: +44 (0)20 8996 9001.
Fax: +44 (0)20 8996 7001. Email: orders@bsi-global.com. Standards are also available from the BSI website at <http://www.bsi-global.com>.

In response to orders for international standards, it is BSI policy to supply the BSI implementation of those that have been published as British Standards, unless otherwise requested.

Information on standards

BSI provides a wide range of information on national, European and international standards through its Library and its Technical Help to Exporters Service. Various BSI electronic information services are also available which give details on all its products and services. Contact the Information Centre.
Tel: +44 (0)20 8996 7111. Fax: +44 (0)20 8996 7048. Email: info@bsi-global.com.

Subscribing members of BSI are kept up to date with standards developments and receive substantial discounts on the purchase price of standards. For details of these and other benefits contact Membership Administration.
Tel: +44 (0)20 8996 7002. Fax: +44 (0)20 8996 7001.
Email: membership@bsi-global.com.

Information regarding online access to British Standards via British Standards Online can be found at <http://www.bsi-global.com/bsonline>.

Further information about BSI is available on the BSI website at <http://www.bsi-global.com>.

Copyright

Copyright subsists in all BSI publications. BSI also holds the copyright, in the UK, of the publications of the international standardization bodies. Except as permitted under the Copyright, Designs and Patents Act 1988 no extract may be reproduced, stored in a retrieval system or transmitted in any form or by any means – electronic, photocopying, recording or otherwise – without prior written permission from BSI.

This does not preclude the free use, in the course of implementing the standard, of necessary details such as symbols, and size, type or grade designations. If these details are to be used for any other purpose than implementation then the prior written permission of BSI must be obtained.

Details and advice can be obtained from the Copyright & Licensing Manager.
Tel: +44 (0)20 8996 7070. Fax: +44 (0)20 8996 7553.
Email: copyright@bsi-global.com.