

BS EN ISO 18217:2015



BSI Standards Publication

# Safety of woodworking machines — Edge-banding machines fed by chain(s)

**bsi.**

...making excellence a habit.™

**National foreword**

This British Standard is the UK implementation of EN ISO 18217:2015. It supersedes BS EN 1218-4:2004+A2:2009 which is withdrawn.

The UK participation in its preparation was entrusted to Technical Committee MTE/23, Woodworking machines.

A list of organizations represented on this committee can be obtained on request to its secretary.

This publication does not purport to include all the necessary provisions of a contract. Users are responsible for its correct application.

© The British Standards Institution 2015.  
Published by BSI Standards Limited 2015

ISBN 978 0 580 81660 4

ICS 79.120.10

**Compliance with a British Standard cannot confer immunity from legal obligations.**

This British Standard was published under the authority of the Standards Policy and Strategy Committee on 30 September 2015.

**Amendments/corrigenda issued since publication**

Date	Text affected
------	---------------

---

EUROPEAN STANDARD

**EN ISO 18217**

NORME EUROPÉENNE

EUROPÄISCHE NORM

September 2015

ICS 79.120.10

Supersedes EN 1218-4:2004+A2:2009

English Version

## Safety of woodworking machines - Edge-banding machines fed by chain(s) (ISO 18217:2015)

Sécurité des machines à bois - Machines à plaquer sur  
chant à alimentation par chaîne(s) (ISO 18217:2015)

Sicherheit von Holzbearbeitungsmaschinen -  
Kantenanleimmaschinen mit Kettenbandvorschub (ISO  
18217:2015)

This European Standard was approved by CEN on 27 June 2015.

CEN members are bound to comply with the CEN/CENELEC Internal Regulations which stipulate the conditions for giving this European Standard the status of a national standard without any alteration. Up-to-date lists and bibliographical references concerning such national standards may be obtained on application to the CEN-CENELEC Management Centre or to any CEN member.

This European Standard exists in three official versions (English, French, German). A version in any other language made by translation under the responsibility of a CEN member into its own language and notified to the CEN-CENELEC Management Centre has the same status as the official versions.

CEN members are the national standards bodies of Austria, Belgium, Bulgaria, Croatia, Cyprus, Czech Republic, Denmark, Estonia, Finland, Former Yugoslav Republic of Macedonia, France, Germany, Greece, Hungary, Iceland, Ireland, Italy, Latvia, Lithuania, Luxembourg, Malta, Netherlands, Norway, Poland, Portugal, Romania, Slovakia, Slovenia, Spain, Sweden, Switzerland, Turkey and United Kingdom.



EUROPEAN COMMITTEE FOR STANDARDIZATION  
COMITÉ EUROPÉEN DE NORMALISATION  
EUROPÄISCHES KOMITEE FÜR NORMUNG

**CEN-CENELEC Management Centre: Avenue Marnix 17, B-1000 Brussels**

## European foreword

This document (EN ISO 18217:2015) has been prepared by Technical Committee ISO/TC 39 “Machine tools” in collaboration with Technical Committee CEN/TC 142 “Woodworking machines - Safety” the secretariat of which is held by UNI.

This European Standard shall be given the status of a national standard, either by publication of an identical text or by endorsement, at the latest by March 2016, and conflicting national standards shall be withdrawn at the latest by March 2016.

Attention is drawn to the possibility that some of the elements of this document may be the subject of patent rights. CEN [and/or CENELEC] shall not be held responsible for identifying any or all such patent rights.

This document supersedes EN 1218-4:2004+A2:2009.

This document has been prepared under a mandate given to CEN by the European Commission and the European Free Trade Association, and supports essential requirements of EU Directive(s).

For relationship with EU Directive(s), see informative Annex ZA, which is an integral part of this document.

According to the CEN-CENELEC Internal Regulations, the national standards organizations of the following countries are bound to implement this European Standard: Austria, Belgium, Bulgaria, Croatia, Cyprus, Czech Republic, Denmark, Estonia, Finland, Former Yugoslav Republic of Macedonia, France, Germany, Greece, Hungary, Iceland, Ireland, Italy, Latvia, Lithuania, Luxembourg, Malta, Netherlands, Norway, Poland, Portugal, Romania, Slovakia, Slovenia, Spain, Sweden, Switzerland, Turkey and the United Kingdom.

## Endorsement notice

The text of ISO 18217:2015 has been approved by CEN as EN ISO 18217:2015 without any modification.

**Annex ZA**  
(informative)

**Relationship between this European Standard and the Essential  
Requirements of EU Directive 2006/42/EC**

This European Standard has been prepared under a mandate given to CEN by the European Commission and the European Free Trade Association to provide one means of conforming to Essential Requirements of the New Approach Machinery Directive 2006/42/EC.

Once this standard is cited in the Official Journal of the European Union under that Directive, compliance with the normative clauses of this standard confers, within the limits of the scope of this standard, a presumption of conformity with the corresponding Essential Requirements of that Directive and associated EFTA regulations.

**WARNING** Other requirements and other EU Directives may be applicable to the products falling within the scope of this standard.

# Contents

Page

<b>Foreword</b> .....	<b>v</b>
<b>Introduction</b> .....	<b>vi</b>
<b>1 Scope</b> .....	<b>1</b>
<b>2 Normative references</b> .....	<b>2</b>
<b>3 Terms and definitions</b> .....	<b>2</b>
<b>4 List of significant hazards</b> .....	<b>7</b>
<b>5 Safety requirements and/or protective measures</b> .....	<b>9</b>
5.1 General.....	9
5.2 Controls.....	10
5.2.1 Safety and reliability of control systems.....	10
5.2.2 Position of controls.....	10
5.2.3 Starting.....	11
5.2.4 Stop controls.....	11
5.2.5 Integrated feed.....	12
5.2.6 Mode selection.....	13
5.2.7 Overspeed control for milling tools.....	14
5.2.8 Failure of any power supply.....	14
5.2.9 Failure of the control circuits.....	15
5.2.10 Tele-service.....	15
5.3 Protection against mechanical hazards.....	15
5.3.1 Stability.....	15
5.3.2 Risk of break-up during operation.....	16
5.3.3 Tool holder and tool design.....	16
5.3.4 Braking.....	18
5.3.5 Devices to minimize the possibility or the effect of ejection or kick-back.....	18
5.3.6 Work-piece supports and guides.....	19
5.3.7 Prevention of access to moving parts.....	21
5.4 Protection against non-mechanical hazards.....	28
5.4.1 Fire.....	28
5.4.2 Noise.....	29
5.4.3 Emission of chips and dust.....	30
5.4.4 Electricity.....	31
5.4.5 Ergonomics and handling.....	31
5.4.6 Lighting.....	32
5.4.7 Pneumatics and hydraulics.....	32
5.4.8 Electromagnetic compatibility.....	32
5.4.9 Static electricity.....	32
5.4.10 Isolation.....	32
5.4.11 Maintenance.....	33
5.4.12 Errors of fitting.....	33
5.4.13 Heat.....	33
5.4.14 Substances.....	33
5.4.15 Artificial optical radiation.....	33
<b>6 Information for use</b> .....	<b>33</b>
6.1 Warning devices.....	33
6.2 Marking.....	34
6.3 Instruction handbook.....	35
<b>Annex A (normative) Braking tests</b> .....	<b>39</b>
<b>Annex B (normative) Impact test method for guards</b> .....	<b>41</b>
<b>Annex C (normative) Stability test for displaceable machines</b> .....	<b>44</b>

<b>Annex D (informative) Performance level required</b> .....	<b>45</b>
<b>Bibliography</b> .....	<b>47</b>

## Foreword

ISO (the International Organization for Standardization) is a worldwide federation of national standards bodies (ISO member bodies). The work of preparing International Standards is normally carried out through ISO technical committees. Each member body interested in a subject for which a technical committee has been established has the right to be represented on that committee. International organizations, governmental and non-governmental, in liaison with ISO, also take part in the work. ISO collaborates closely with the International Electrotechnical Commission (IEC) on all matters of electrotechnical standardization.

The procedures used to develop this document and those intended for its further maintenance are described in the ISO/IEC Directives, Part 1. In particular the different approval criteria needed for the different types of ISO documents should be noted. This document was drafted in accordance with the editorial rules of the ISO/IEC Directives, Part 2 (see [www.iso.org/directives](http://www.iso.org/directives)).

Attention is drawn to the possibility that some of the elements of this document may be the subject of patent rights. ISO shall not be held responsible for identifying any or all such patent rights. Details of any patent rights identified during the development of the document will be in the Introduction and/or on the ISO list of patent declarations received (see [www.iso.org/patents](http://www.iso.org/patents)).

Any trade name used in this document is information given for the convenience of users and does not constitute an endorsement.

For an explanation on the meaning of ISO specific terms and expressions related to conformity assessment, as well as information about ISO's adherence to the WTO principles in the Technical Barriers to Trade (TBT) see the following URL: [Foreword - Supplementary information](#).

The committee responsible for this document is ISO/TC 39, *Machine tools*, Subcommittee SC 4, *Woodworking machines*.



## Introduction

This International Standard has been prepared to be a Harmonized Standard to provide one means of conforming to the Essential Safety Requirements of the Machinery Directive of the European Union and associated EFTA regulations.

This document is a type-C standard as defined in ISO 12100:2010.

The machinery concerned and the extent to which hazards, hazardous situations, and events are covered are indicated in the scope of this International Standard.

When requirements of this type-C standard are different from those which are stated in type-A or type-B standards, the requirements of this type-C standard take precedence over the requirements of the other International Standards for machines that have been designed and built according to the requirements of this type-C standard.

The requirements of this International Standard concern designers, manufacturers, suppliers, and importers of machines described in the Scope.

This International Standard also includes a list of informative items to be provided by the manufacturer to the user.

Common requirements for tooling are given in EN 847-1:2013 and EN 847-2:2013.

# Safety of woodworking machines — Edge-banding machines fed by chain(s)

## 1 Scope

This International Standard deals with all significant hazards, hazardous situations, and events as listed in [Clause 4](#), which are relevant to edge banding machines fed by chains with manual loading and unloading and maximum work-piece height capacity of 100 mm, when they are used as intended and under the conditions foreseen by the manufacturer, including reasonably foreseeable misuse.

The work-piece is fed through the processing units by an integrated feed. Feeding chains also include “feeding belts”.

For the purpose of this International Standard, an edge banding machine fed by chains is hereinafter referred to as “machine”.

The machine is designed to process in one pass, one end (single end machine), or both ends (double end machine) panels of wood materials with similar physical characteristics as wood, as well as gypsum plaster boards.

Edges to be applied by the machine can be made of paper, melamine, plastic or composite materials, aluminium or light alloy, veneer or solid wood.

This International Standard also applies to machines fitted with the following:

- auxiliary devices essential for edge banding machines fed by chains (see [3.1](#));
- sanding belt units;
- fixed or movable workpiece support;
- automatic tool changing;
- automatic panel returner.

This International Standard also includes information to be provided by the manufacturer to the user.

This International Standard does not deal with any hazards relating to the following:

- a) systems for loading and unloading of the work-piece to a single machine other than automatic panel returner;
- b) single machine being used in combination with any other machine (as part of a line);
- c) wireless mobile control sets;
- d) additional equipment for grooving and for cutting by circular saw blade, installed out of the integral enclosure and/or whose tools protrude out of the integral enclosure;
- e) plasma unit, power laser unit, and hot-air-jet unit.

This International Standard applies to machines that are manufactured after the date of issue of this International Standard.

## 2 Normative references

The following documents, in whole or in part, are normatively referenced in this document and are indispensable for its application. For dated references, only the edition cited applies. For undated references, the latest edition of the referenced document (including any amendments) applies.

ISO 4413, *Hydraulic fluid power — General rules and safety requirements for systems and their components*

ISO 4414:2010, *Pneumatic fluid power — General rules and safety requirements for systems and their components*

ISO 7960:1995, *Airborne noise emitted by machine tools — Operating conditions for woodworking machines*

ISO 12100:2010, *Safety of machinery — General principles for design — Risk assessment and risk reduction*

ISO 13732-1:2006, *Ergonomics of the thermal environment — Methods for the assessment of human responses to contact with surfaces — Part 1: Hot surfaces*

ISO 13849-1:2006, *Safety of machinery — Safety-related parts of control systems — Part 1: General principles for design*

ISO 13850, *Safety of machinery — Emergency stop — Principles for design*

ISO 14118:2000, *Safety of machinery — Prevention of unexpected start-up*

ISO 14119:2013, *Safety of machinery — Interlocking devices associated with guards — Principles for design and selection*

IEC 13856-2, *Safety of machinery — Pressure sensitive protection devices — Part 2: General principles for the design and testing of pressure sensitive edges and pressure sensitive bars*

IEC 60204-1:2005, *Safety of machinery — Electrical equipment of machines — Part 1: General requirements*

IEC 60439-1, *Low-voltage switchgear and controlgear assemblies — Part 1: Type-tested and partially type-tested assemblies*

IEC 60529, *Degrees of protection provided by enclosures (IP Code)*

IEC 61310-1:2007, *Safety of machinery — Indication, marking and actuation — Part 1: Requirements for visual, acoustic and tactile signals*

IEC 61496-2, *Safety of machinery — Electro-sensitive protective equipment — Part 2: Particular requirements for equipment using active opto-electronic protective devices (AOPDs)*

EN 50370-1, *Electromagnetic compatibility (EMC) — Product family standard for machine-tools — Part 1: Emission*

EN 50370-2, *Electromagnetic compatibility (EMC) — Product family standard for machine-tools — Part 2: Immunity*

## 3 Terms and definitions

For the purposes of this document, the terms and definitions given in ISO 12100:2010 and the following apply.

### 3.1 edge banding machine fed by chains

machine designed for bonding in one pass the edge band on one end of the work-piece (single end edge banding machine) or on both ends of the work-piece (double end edge banding machine), consisting of an edge banding zone with various units (e.g. heating, bonding, and pressing for flexible or solid edges) and a zone for additional operations such as snipping, trimming, milling, sanding, polishing, chamfering, etc., where, in addition the edge banding zone, can be preceded by a sizing/profiling zone

Note 1 to entry: The main parts of a single end machine and a double end machine and their terminology are illustrated in [Figure 1](#) and [Figure 2](#), respectively.

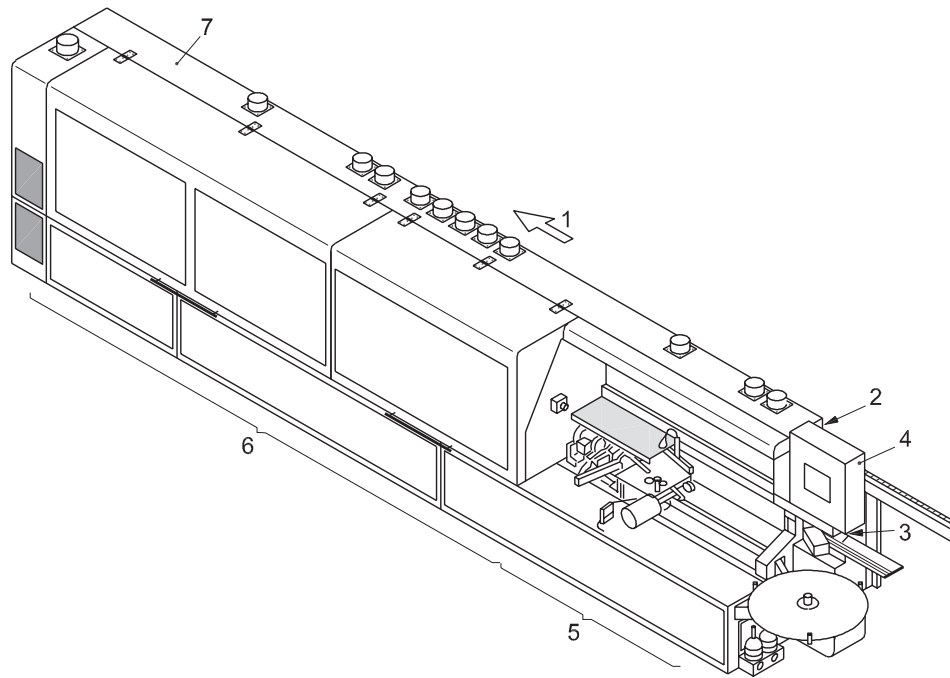

#### Key

- 1 feed direction
- 2 top pressure beam
- 3 chain beam
- 4 controls
- 5 edge banding zone
- 6 additional operation zone
- 7 integral closure

**Figure 1 — Example of a single end machine**

### 3.2 material with similar physical characteristics to wood

wood-based material (e.g. chipboard, fibreboard, plywood) also when covered with plastic or light alloy laminates/edges; cork, bone, rigid rubber, or plastic

### 3.3 integrated feed

feed mechanism for the work-piece or tool which is integrated with the machine and where the work-piece or machine element with incorporated tool are held and controlled mechanically during the machining operation

**3.4  
ejection**

unexpected movement of the work-piece or parts of it or part of the machine from the machine during processing

**3.5  
run-up time**

time elapsed from the actuation of the start control device until the spindle reaches the intended speed

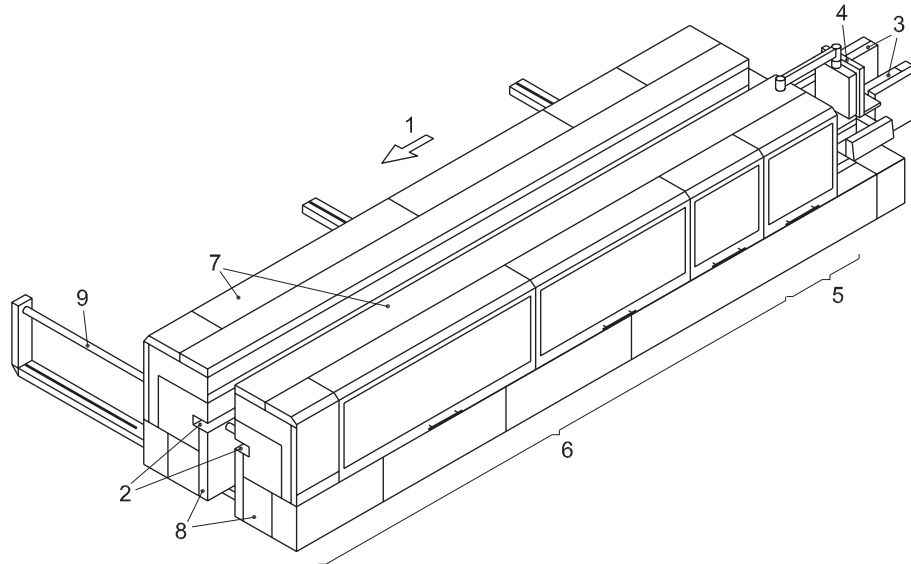

**Key**

- 1 feed direction
- 2 top pressure beam
- 3 chain beam
- 4 controls
- 5 edge banding zone
- 6 additional operation zone
- 7 integral closure
- 8 machine halves
- 9 feed cross drive shaft

**Figure 2 — Example of a double end machine**

**3.6  
run-down time**

time elapsed from the actuation of the stop control device to spindle stand still

**3.7  
machine actuator**

power mechanism used to effect the motion of the machine

**3.8  
dynamic processing unit**

unit which moves with the work-piece during processing and returns to its starting position ready for the following (succeeding) work-piece

Note 1 to entry: An example of dynamic processing unit is shown in [Figure 3](#).

### 3.9 machine half

part of a machine consisting of a frame, chain beam, top pressure beam, and working units

Note 1 to entry: Each machine half processes one, different, end of the work-piece. One or both machine halves are capable of being moved to accept work-pieces of different dimensions.

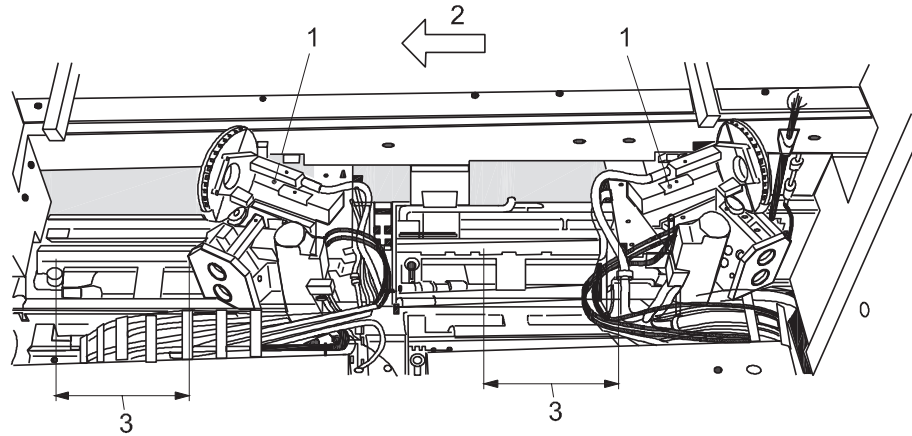

#### Key

- 1 dynamic processing unit (e.g. sniper saw)
- 2 feed direction
- 3 movement zone

Figure 3 — Example of a dynamic processing unit

### 3.10 integral enclosure (double and single end machines)

guarding designed to fit close to the machine and provide a measure of sound attenuation and where certain setting adjustments may be available outside the enclosure

Note 1 to entry: Each machine half is provided with separate guarding and on the adjustable machine half/halves this guarding moves with it when adjustment is made for work-piece width.

### 3.11 displaceable machine

machine which is located on the floor, stationary during use and equipped with a device, normally wheels, which allow it to be moved between locations

### 3.12 automatic panel returner

Powered system that brings the panel from the machine end to the loading position

Note 1 to entry: See [Figure 5](#).

### 3.13 tele-service

machine diagnosis (including trouble-shooting), software update and tele-control from a remote service site

**3.14**  
**safety-related embedded software**  
**SRESW**  
**firmware**  
**system software**

software that is part of the system supplied by the control manufacturer and which is not accessible for modification by the user of the machinery

Note 1 to entry: Firmware or system software are examples of embedded software (ISO 13849-1:2006, 3.1.37).

Note 2 to entry: Manufacturer means manufacturer of the system.

Note 3 to entry: For example, the operating system of a speed monitoring device.

**3.15**  
**safety-related application software**  
**SRASW**

software specific to the application, implemented by the machine manufacturer, and generally containing logic sequences, limits, and expressions that control the appropriate inputs, outputs, calculations, and decisions necessary to meet the SRP/CS requirements

[SOURCE: ISO 13849-1:2006, 3.1.36]

**3.16**  
**safety-related part of a control system**  
**SRP/CS**

part of a control system that responds to safety-related input signals and generates safety-related output signals

Note 1 to entry: The combined safety-related parts of a control system start at the point where the safety-related input signals are initiated (including e.g. the actuating cam and the roller of the position switch) and end at the output of the power control elements (including, for example, the main contacts of the contactor).

[SOURCE: ISO 13849-1:2006, 3.1.1]

**3.17**  
**safety function**

function of the machine whose failure can result in an immediate increase of the risk

[SOURCE: ISO 13849-1:2006, 3.1.20]

**3.18**  
**information from the supplier**

statements, sales literature, leaflets, or other where a manufacturer (supplier) declares either the characteristics of e.g. a material or product or the compliance of the material or product to a relevant standard

**3.19**  
**performance level**  
**PL**

discrete level used to specify the ability of safety-related parts of control systems to perform a safety function under foreseeable conditions

[SOURCE: ISO 13849-1:2006, 3.1.23]

**3.20**  
**operational stop**

stop control that does not cut off the energy supply to the actuators, where the stop condition is monitored and maintained

### 3.21

#### **power-on control device**

control device that enables providing power to machines actuators

EXAMPLE Powering auxiliary circuit.

Note 1 to entry: Power-on is not intended as the main switch.

### 3.22

#### **MODE 1: automatic mode**

condition for automatic processing, where all safeguards of the machine are in place and functional and some or all machine actuators are activated

### 3.23

#### **MODE 2: adjustment mode**

condition for adjustment of tools and other processing units, where feed of the work-piece is possible under hold-to-run control only

### 3.24

#### **MODE 3: fine adjustment mode**

condition for fine adjustment of tools and other processing units, where opening of parts of the peripheral enclosure is permitted for a limited period of time, while the tools, other processing units, and the feed are running

## 4 List of significant hazards

This Clause contains all significant hazards, hazardous situations, and events (see ISO 12100:2010) identified by risk assessment as significant for the machines, as defined in the scope and which require action to eliminate or reduce the risk. This International Standard deals with these significant hazards by defining safety requirements and/or measures or by reference to relevant standards.

These hazards are listed in [Table 1](#).



**Table 1 — List of significant hazards**

No	Hazards, hazardous situations, and hazardous events	ISO 12100:2010	Relevant subclause of this International Standard
1	<b>Mechanical hazards</b> related to — machine parts or workpieces:		
	a) shape;	6.2.2.1, 6.2.2.2, 6.3	<a href="#">5.3.2</a> , <a href="#">5.3.3</a> , <a href="#">5.3.7</a> , <a href="#">Annex B</a>
	b) relative location;		<a href="#">5.2.2</a> , <a href="#">5.2.5</a> , <a href="#">5.3.5</a> , <a href="#">5.3.6</a> , <a href="#">5.3.7</a> , <a href="#">5.4.5</a> , <a href="#">6.3</a>
	c) mass and velocity (kinetic energy of elements in controlled or uncontrolled motion);		<a href="#">5.2.7</a> , <a href="#">5.3.7</a> , <a href="#">Annex B</a>
	d) mechanical strength.		<a href="#">5.3.2</a> , <a href="#">5.3.3</a>
	— accumulation of energy inside the machinery:		
	e) liquids and gases under pressure	6.2.10, 6.3.5.4	<a href="#">5.3.3</a> , <a href="#">5.4.7</a> , <a href="#">Annex B</a>
1.1	Crushing hazard		<a href="#">5.3.6</a> , <a href="#">5.3.7</a>
1.2	Shearing hazard		<a href="#">5.3.6</a> , <a href="#">5.3.7</a>
1.3	Cutting or severing hazard		<a href="#">5.3.3</a> , <a href="#">5.3.4</a> , <a href="#">5.3.7</a>
1.4	Entanglement hazard		<a href="#">5.3.3</a> , <a href="#">5.3.4</a> , <a href="#">5.3.6</a> , <a href="#">5.3.7</a>
1.5	Drawing-in or trapping hazard		<a href="#">5.3.7</a>
1.6	Impact hazard		<a href="#">5.3.7</a>
1.8	Friction or abrasion hazard		<a href="#">5.3.4</a>
1.9	High pressure fluid injection or ejection hazard	6.2.10	<a href="#">5.3.4</a> , <a href="#">5.4.11</a>
2	<b>Electrical hazards</b> due to:		
2.1	Contact of persons with live parts (direct contact)	6.2.9, 6.3.5.4	<a href="#">5.4.4</a> , <a href="#">5.4.14</a>
2.2	Contact of persons with parts which have become live under faulty conditions (indirect contact)	6.2.9	<a href="#">5.4.4</a> , <a href="#">5.4.11</a>
2.4	Electrostatic phenomena	6.2.9	<a href="#">5.4.9</a>
3	<b>Thermal hazards</b> resulting in:		
3.1	Burns, scalds, and other injuries by a possible contact of persons with objects or materials with an extreme high or low temperature, by flames or explosions and also by the radiation of heat sources	6.2.4	<a href="#">5.4.13</a> , <a href="#">5.4.14</a>
3.2	Damage to health by hot or cold working environment	6.2.4	<a href="#">5.4.13</a> , <a href="#">5.4.14</a>
4	<b>Hazards generated by noise</b> , resulting in:		
4.1	Hearing loss (deafness), other physiological disorders (loss of balance, loss of awareness)	6.2.2.2, 6.3	<a href="#">5.4.2</a>
4.2	Interference with speech communication, acoustic signals.	6.2.2.2, 6.3	<a href="#">5.4.2</a>
7	<b>Hazards generated by materials and substances</b> (and their constituent elements) processed or used by the machinery		
7.1	Hazards from contact with or inhalation of harmful fluids and dusts	6.2.3, 6.2.4	<a href="#">5.4.3</a> , <a href="#">5.4.14</a> , <a href="#">6.3</a>

Table 1 (continued)

No	Hazards, hazardous situations, and hazardous events	ISO 12100:2010	Relevant subclause of this International Standard
7.2	Fire hazard	6.2.4	<a href="#">5.4.1</a> , <a href="#">5.4.3</a>
8	<b>Hazards generated by neglecting ergonomic principles in machinery design</b> related to:		
8.1	Unhealthy postures or excessive effort	6.2.7, 6.2.8, 6.2.11.12, 6.3.5.5, 6.3.5.6	<a href="#">5.2.2</a> , <a href="#">5.4.5</a> , <a href="#">6.3</a>
8.2	Hand-arm or foot-leg anatomy	6.2.8.3	<a href="#">5.2.2</a> , <a href="#">5.4.5</a> , <a href="#">6.3</a>
8.4	Local lighting	6.2.8.6	<a href="#">5.4.6</a> , <a href="#">6.3</a>
8.6	Human error, human behaviour	6.2.8.1, 6.2.11.8, 6.2.11.10, 6.3.5.2, 6.4	<a href="#">5.4.12</a> , <a href="#">6.3</a>
8.7	Design, location, or identification of manual controls	6.2.8.7, 6.2.11.8	<a href="#">5.2.2</a>
8.8	Design or location of visual display units	6.2.8.8, 6.4.2	<a href="#">5.2.2</a>
9	<b>Combination of hazards</b>	6.3.2.1	<a href="#">5.2.6</a> , <a href="#">5.2.7</a>
10	<b>Unexpected start up, unexpected overrun/overspeed</b> (or any similar malfunction) from:		
10.1	Failure/disorder of the control system	6.2.11, 6.3.5.4	<a href="#">5.2.1</a> , <a href="#">5.2.9</a>
10.2	Restoration of energy supply after an interruption	6.2.11.4	<a href="#">5.2.8</a> , <a href="#">5.4.7</a> , <a href="#">5.4.10</a>
10.3	External influences on electrical equipment	6.2.11.11	<a href="#">5.4.4</a> , <a href="#">5.4.8</a>
10.6	Errors made by the operator (due to mismatch of machinery with human characteristics and abilities, see 8.6)	4.9 6.2.8, 6.2.11.8, 6.2.11.10, 6.3.5.2, 6.4	<a href="#">5.2.1</a> , <a href="#">5.4.5</a> , <a href="#">6.3</a>
11	<b>Impossibility of stopping the machine in the best possible conditions</b>	6.2.11.1, 6.2.11.3, 6.3.5.2	<a href="#">5.2.2</a> , <a href="#">5.2.5</a> , <a href="#">5.2.7</a>
13	<b>Failure of the power supply</b>	6.2.11.1, 6.2.11.4	<a href="#">5.2.8</a>
14	<b>Failure of the control circuit</b>	6.2.11, 6.3.5.4	<a href="#">5.2.9</a>
15	<b>Errors of fitting</b>	6.2.7, 6.4.5	<a href="#">5.4.12</a> , <a href="#">6.3</a>
16	<b>Break-up during operation</b>	6.2.3	<a href="#">5.3.2</a>
17	<b>Falling or ejected objects or fluids</b>	6.2.3, 6.2.10	<a href="#">5.2.7</a> , <a href="#">5.3.5</a> , <a href="#">5.4.4</a> , <a href="#">6.3</a> , <a href="#">Annex B</a>
18	<b>Loss of stability/overtipping of machinery</b>	6.3.2.6	<a href="#">5.3.1</a>
19	<b>Slip, trip, and fall hazards in relationship with machinery (because of their mechanical nature)</b>	6.3.5.6	<a href="#">6.3</a>

## 5 Safety requirements and/or protective measures

### 5.1 General

The machine shall comply with the safety requirements and/or protective measures of [Clause 5](#).

In addition, the machine should be designed according to the principles of ISO 12100:2010 for hazards relevant but not significant, which are not dealt with by this International Standard (e.g. sharp edges of the machine frame).

See ISO 12100:2010, 6.2 for guidance in connection with risk reduction by design and see ISO 12100:2010, 6.3 for safeguarding measures.

## 5.2 Controls

### 5.2.1 Safety and reliability of control systems

For the design and implementation of any safety function, either realized in electric, pneumatic, hydraulic, or mechanic technology, the appropriate requirements of ISO 13849-1:2006 shall apply.

Machine safety functions are implemented and ensured through Safety-related Parts of the Control System (SRP/CS) that shall achieve a relevant minimum Performance Level (PL) required. This requirement is given for each safety function in the relevant subclause of [Clause 5](#).

[Table D.1](#) shows  $PL_r$  for each safety function at a glance. However, [Clause 5](#) subclauses text remains the sole proper normative reference for the full requirements and explanations, which might not be summarized enough to fit in [Table D.1](#).

Wherever in this International Standard PL is mentioned, the requirements for PL refer to ISO 13849-1:2006.

*Verification:* By checking the relevant drawings and/or circuit diagrams and inspection of the machine, evaluation of the achieved performance level according to ISO 13849-1:2008, 4.5.

### 5.2.2 Position of controls

The main electrical control devices of the machine for power-on, starting a tool spindle, other processing spindles, normal stopping, integrated feed, top pressure beam movement, machine half movement, and mode selection shall be located together and situated such that the loading position can be seen.

Additional control devices for starting, operational/normal stopping (if provided) may be duplicated/provided on mobile control sets with cable connection or wireless taking account of the requirements of [5.2.4.3](#) for emergency stop.

When a wireless control set loses its connection to the machine, a normal stop shall be automatically activated.

Hold-to-run control devices shall be located so that the operator, when actuating them, can see the controlled movements [see [5.2.6.2 c\)](#)].

No reset function control devices, no control devices for power-on, and no mode selection shall be positioned on mobile control sets.

Emergency stop controls shall be fitted at the following locations:

- a) on each mobile or fixed set of controls;
- b) at the loading and unloading positions of each machine half as long as there is no set of controls;
- c) not more than 0,5 m from each hold-to-run device;
- d) inside each enclosure where a mode selection switch is provided (see [5.2.6](#)) and positioned with a maximum distance of 2 m from each other;
- e) at the loading area for glue and edges when outside a specific enclosure.

*NOTE* A single emergency stop control can fulfil, by virtue of its installed position, the function of more than one of the above requirements. If two of the above locations can be reached from each other, only one emergency stop control can be provided.

As an exception to b), emergency stop control at the unloading position is not required on single-end machines with a maximum length of workpiece support of 2 m.

*Verification:* By checking the relevant drawings and/or circuit diagrams, inspection of the machine, and relevant functional testing of the machine.

### 5.2.3 Starting

A power-on control device shall be provided and protected against unintended actuation (e.g. shrouded).

Power-on activation in automatic mode shall only be possible when all safeguards are in place and functional. This is achieved by the interlocking arrangements described in 5.3.7.

NOTE 1 For power enabling in MODE 2 and MODE 3, see 5.2.6.

Process start or restart shall only be possible after power-on activation.

NOTE 2 No PL is required for process starting and restarting.

When power is supplied to a tool spindle drive motor and any other processing spindle drive motor, this shall be indicated permanently or through the request of the operator, e.g. by a light signal near to the start control or integrated in the start button, or by using a two position switch or through the operator interrogating the control computer.

In machines provided with MODE 2, it shall be possible to start each spindle drive and feed drive separately.

Closure of movable interlocked guards shall not lead to an automatic restart of hazardous movements.

The SRP/CS for power-on control shall achieve at least PL = c.

The SRP/CS for starting spindle drives and feed drive shall achieve at least PL = b.

*Verification:* By checking the relevant drawings and/or circuit diagrams, inspection, and relevant functional testing on the machine.

### 5.2.4 Stop controls

#### 5.2.4.1 Normal stop

A stop control shall be fitted, which, when actuated, stops all machine actuators except glue heater and cuts power to them once stopping is complete, unless STO in accordance with EN 61800-5-2:2007 is used.

When STO is provided in accordance with EN 61800-5-2:2007, no disconnection by contactor is required.

NOTE For normal stopping of PDS(SR) (power drive system, safety-related), see EN 61800-5-2:2007, 4.2.2.2 for “safe torque off (STO)” and EN 61800-5-2:2007, 4.2.2.3 for “safe stop 1 (SS1)”.

For machine actuators stopped in stop category 0 according IEC 60204-1:2005, power shall be cut to these actuators except work-piece clamping (if fitted) unless STO according to EN 61800-5-2:2007 is used.

For machine actuators stopped in stop category 1, the stopping sequence shall be the following:

- cut power to these machine actuators except work-piece clamping (if fitted) unless STO according to EN 61800-5-2:2007 is used and actuate the brakes;
- cut power to brakes (if electrical brake is fitted) after tool spindle has come to rest, e.g. by using a time delay.

The SRP/CS for normal stopping initiation shall achieve at least PL = c.

The above requirements shall be satisfied at the level of the control circuits. If a time-delay device is used, the time delay shall achieve at least PL = c and shall at least be more than the maximum run-down time of the machine and either the time delay shall be fixed or the adjustment mechanism shall be sealed.

*Verification:* By checking the relevant drawings and/or circuit diagrams, inspection, and relevant functional testing of the machine.

#### 5.2.4.2 Operational stop

If an operational stop function is provided for intervention in the machine while drive systems remain under control, the following requirements shall apply.

The stop function provided (e.g. cycle stop) shall be of category 2 in accordance with the requirements of IEC 60204-1:2005, 9.2.2 actuated in conjunction with standstill monitoring and the SRP/CS for standstill monitoring shall achieve at least PL = c.

NOTE For operational stop of PDS(SR), see EN 61800-5-2:2007, 4.2.3.1 for "safe operating stop (SOS)" and EN 61800-5-2:2007, 4.2.2.4 for "safe stop 2 (SS2)".

When initiated, the stopping sequence shall be the following:

- a) stop the axes movements;
- b) stop spindle rotation and actuate the brake (if provided);
- c) when braking sequence is complete, cut power to brake (if electrical brake is fitted).

*Verification:* By checking the relevant drawings and/or circuit diagrams, inspection, and relevant functional testing of the machine.

#### 5.2.4.3 Emergency stop

ISO 13850 shall apply and in addition:

Machines shall be fitted with emergency stop controls conforming to the requirements of IEC 60204-1:2005, 9.2.5.4 and 10.7. However, the requirements of IEC 60204-1:2005, 10.7.4 do not apply.

The requirements for normal stopping shown in [5.2.4](#) shall apply without the exception on the glue heater.

The SRP/CS for emergency stop initiation shall achieve at least PL = c.

*Verification:* By checking the relevant drawings and/or circuit diagrams, measurement, inspection, and relevant functional testing of the machine.

#### 5.2.5 Integrated feed

##### 5.2.5.1 General

In automatic mode (MODE 1), start of the feed motor shall only be possible when the tool spindles motors are running at the intended speed or the tools of all spindles not involved in the current operation cannot come into contact with the work-piece (the tools are removed from the spindles or the non-rotating spindles are retracted to a non-cutting position).

The SRP/CS for interlocking of feed start with spindle tool drive motor shall achieve at least PL = b.

##### 5.2.5.2 Requirements with respect to spindle position

For spindle units that are adjusted manually (by hand wheel or power operated), see [6.3 n](#)).

For automatically adjusted spindle units under NC or CNC-control, one of the following requirements shall be fulfilled to ensure that not rotating spindles, where the tool has not been removed, are retracted to a non-cutting position:

- a) limit position device at the non-cutting position shall be provided;
- b) PLC shall start retracting the tool from the working position.

The SRP/CS for the interlocking of feed start with spindle retraction shall achieve at least PL = b.

*Verification:* By checking the relevant drawings and/or circuit diagrams, inspection, and relevant functional testing of the machine.

### 5.2.5.3 Requirements for pressure beam height adjustment respect integrated feed

For manual height adjustment of the feed mechanism, by hand wheel or power operated, instructions shall be given as per [6.3 o](#)).

For automatic height adjustment of the feed mechanism under NC or CNC-control, upward movement of the feed mechanism while the tools are rotating shall only be possible providing a means of detecting that any workpiece entered the in-feed of the machine have passed the tools. The SRP/CS for this detection system shall achieve at least  $PL = b$ .

*Verification:* By checking the relevant drawings and/or circuit diagrams, inspection of the machine, and relevant functional testing of the machine.

## 5.2.6 Mode selection

### 5.2.6.1 General

A mode selection switch shall be provided if the guards have to be opened for adjusting while certain parts of the machine are in motion. The control system for mode selection shall override all other control systems except that for emergency stop and shall be lockable in each position (see ISO 12100:2011, 6.2.11.10).

A deterring/impeding device shall be fitted to prevent horizontal access to the non-cutting part of any rotating tool from inside the enclosure. For the materials and properties of this device, see [5.3.2](#).

The SRP/CS for mode selection shall achieve at least  $PL = c$ .

When switching from an adjustment mode (MODE 2 or MODE 3) back to automatic mode (MODE 1), no movement stop is required.

Where MODE 2 is implemented, it is not required to also implement MODE 3 and vice versa.

*Verification:* By checking the relevant drawings and/or circuit diagrams, inspection, and relevant functional testing of the machine.

### 5.2.6.2 Adjustment mode (MODE 2)

If MODE 2 is implemented for adjustment of tools and other processing units, the following requirements apply:

- a) in the adjustment mode, the normal (automatic) control mode shall be disabled;
- b) selecting the MODE 2 shall initiate stopping of the feed, tool spindles, and other processing units;
- c) movement of the feed and powered adjustment shall only be possible by hold-to-run control. The relevant hold-to run control devices shall be located on a mobile set of controls (see [5.2.2](#) for positioning of hold-to-run control devices);
- d) for dynamic processing units, running the tool spindles, and dynamic movements shall not be possible when the relevant guards are open;
- e) some or all of the tool spindles can run after intentional starting.

The SRP/CS for hold-to-run control shall achieve at least

- 1)  $PL = c$ , or
- 2)  $PL = b$ , if an emergency stop control device is in the vicinity.



*Verification:* By checking the relevant drawings and/or circuit diagrams, measurement, inspection, and relevant functional testing of the machine.

### 5.2.6.3 Fine adjustment mode (MODE 3)

If MODE 3 is implemented for fine adjustment of tools and other processing units while they and the feed are running during machining, the following requirements apply:

- a) selecting MODE 3 shall not initiate any unit adjustment and shall stop the dynamic processing units (spindles and movements) if they are not separately guarded;
- b) a single door with a length of not more than 2,0 m can be opened for a maximum period of 3 min without causing a stop of the feed of the tools (i.e. the interlocking of the door with the drive actuators is still active but the reaction is postponed by 3 min). The SRP/CS for the postponement of the interlocking shall achieve at least PL = c;
- c) dynamic processing units shall be stopped before relevant movable guards are opened and unexpected start-up of the tool spindles and dynamic movements shall be prevented when the relevant guards are open. The SRP/CS for the interlocking of dynamic processing units and movable guards shall achieve at least PL = c.

See also [5.2.2](#) and [5.3.7](#).

*Verification:* By checking the relevant drawings and/or circuit diagrams, measurement, inspection, and relevant functional testing on the machine.

### 5.2.7 Overspeed control for milling tools

On machines fitted with a control unit for infinitely variable speed (e.g. a frequency inverter) for the spindle drive motor, the device shall be such that the real speed shall not exceed the maximum milling tool rotational speed by more than 10 %. If the actual milling tool spindle rotational speed exceeds the maximum tool rotational speed by more than 10 %, the drive motor shall be stopped automatically. This stop shall be of category 0 in accordance with the requirements of IEC 60204-1:2005, 9.2.2.

The SRP/CS for overspeed control for milling tool shall achieve at least PL = c.

As an exception, overspeed control is not required when direct ejection of milling tools or their parts can be excluded, i.e. the plane of rotation is not in line with the slot between the feed chain and top pressure beam.

*Verification:* By checking the relevant drawings and/or circuit diagrams and inspection of the machine.

NOTE For the component characteristics, a confirmation from the component manufacturer can be useful.

### 5.2.8 Failure of any power supply

In case of any supply interruption, the automatic restart of the machine shall be prevented, parameters affecting safety functions of the machine shall not change in an uncontrolled way after restoration of the supply. Where non-return valves are used to maintain workpiece clamping, they shall be fitted directly at the actuating cylinders.

For electric supply, see IEC 60204-1:2005, 7.5 paragraphs 1 and 3.

The requirements of ISO 14118:2000, Clause 6 apply.

The SRP/CS for prevention of unexpected start shall achieve at least PL = c.

*Verification:* By checking the relevant drawings and/or circuit diagrams, inspection, measurement, and relevant functional testing on the machine.

### 5.2.9 Failure of the control circuits

The requirements of ISO 14118:2000, Clause 6 apply and in addition, the control circuits shall be designed so that a line rupture in any circuit (e.g. broken wire, pipe, or hose) will not result in the loss of a safety function (e.g. unexpected start) and shall conform to IEC 60204-1:2005, ISO 4413, and ISO 4414:2010.

*Verification:* By checking the relevant drawings and/or circuit diagrams, inspection, and relevant functional testing of the machine.

### 5.2.10 Tele-service

For machines equipped with tele-service facility, the following requirements apply.

A secure connection line shall be in place between the provider of the tele-service and customer.

The tele-service functions provided for diagnosis, functional software update, and/or tele-control shall be enabled from the machine side.

Indication that the tele-service mode is activated shall be provided at the machine (no PL required), e.g. by a yellow flashing light.

Any single machine shall be readily and clearly identifiable by the tele-service remote operator.

The emergency stop control function at the machine shall take precedence over any command issued by the remote tele-service operator.

Any tele-service operation shall not activate power-on nor mode selection and shall neither suspend nor reset any safeguard or safety function.

Before software update, the machine shall be on, in normal stop condition, and empty from workpieces. After a software update, the PLC shall be rebooted before the machine can be restarted.

The tele-control shall be activated with the machine operator present at the machine. A warning shall appear on the control panel stating that the operator shall check that all safeguards are in place and functional, the machine is in automatic mode (MODE 1), and that he shall stay at the machine during all tele-control operation checking that nobody else is around the machine. A confirmation of the above from the operator shall be required before starting the tele-control function (no PL required).

During tele-control, if the connection between tele-service site and machine is lost, a normal stop shall be activated and the PLC shall be rebooted (no PL required).

After the tele-service operations are accomplished, a message shall appear on the control panel stating that the machine is ready to work.

*Verification:* By checking the relevant drawings and/or circuit diagrams, inspection, and relevant functional testing of the machine.

## 5.3 Protection against mechanical hazards

### 5.3.1 Stability

Stationary machines and auxiliary equipment (e.g. additional work-piece supports) shall be provided with the facility (e.g. holes in the frame) for fixing them to a suitable stable structure (e.g. floor) [see also 6.3 e)].

Displaceable machines fitted with wheels shall have facilities to make them stable during machining (e.g. brakes for the wheels) or a device to retract the wheels from the floor. Displaceable machines shall pass the tests in [Annex C](#).



*Verification:* By checking the relevant drawings and inspection of the machine and for displaceable machines performing the tests in [Annex C](#).

### 5.3.2 Risk of break-up during operation

The guards for the tools shall be manufactured from materials with at least the following properties (see also [5.3.7](#)):

- a) steel with an ultimate breaking strength of at least 350 N mm<sup>-2</sup> and a wall thickness of at least 2 mm;
- b) light alloy with the characteristics shown in [Table 2](#);
- c) polycarbonate with a wall thickness of at least 5 mm;
- d) cast iron with an ultimate tensile strength of at least 200 N mm<sup>-2</sup> and a wall thickness of at least 5 mm;
- e) any other material passing the test in [Annex B](#).

**Table 2 — Light alloy tool guard thickness and tensile strength**

Minimum ultimate tensile strength N mm <sup>-2</sup>	Minimum thickness mm
180	5
240	4
300	3

*Verification:* By checking the relevant drawings, measurement, [Annex B](#) test result where required, and inspection of the machine.

NOTE For the ultimate tensile strength, a confirmation from the manufacturer of the material can be useful.

### 5.3.3 Tool holder and tool design

#### 5.3.3.1 Geometrical performance

The part of the spindle upon which the saw-blades are located shall have a minimum tolerance of g6 in accordance with the requirements of ISO 286-2.

*Verification:* By checking the relevant drawings and by measurement.

#### 5.3.3.2 Strength

The tool spindles shall be manufactured from steel with a minimum ultimate tensile strength of 580 N mm<sup>-2</sup>.

*Verification:* By checking the relevant drawings.

NOTE For the ultimate tensile strength, a confirmation from the manufacturer of the material can be useful.

#### 5.3.3.3 Dimensions for spindles and tools

With regard to the balancing requirements shown in EN 847-1:2013, 6.2.4, the manufacturer shall declare for each spindle the maximum speed, maximum mass, and dimensions of the tools that can be used with it (see also [6.3](#)).

*Verification:* By calculation or other method (e.g. test, accepted standards, and proven experience).

#### 5.3.3.4 Spindle locking

When it is necessary to hold the spindle stationary for tool changing, a spindle holding device shall be provided. This may be, for example, a double spanner or an integral locking bar inserted through the spindle.

*Verification:* By checking the relevant drawings, inspection, and relevant functional testing of the machine.

#### 5.3.3.5 Spindle rings

Where spindle rings are provided, their bores shall have a tolerance of at least H8 in accordance with the requirements of ISO 286-2. The spindle ring clamping surfaces shall be parallel within a tolerance of 0,02 mm.

Spindle rings shall be manufactured in steel with an ultimate tensile strength of at least 350 N mm<sup>-2</sup>.

*Verification:* By checking the relevant drawings, inspection, and measurement.

NOTE For the ultimate tensile strength, a confirmation from the manufacturer of the material can be useful.

#### 5.3.3.6 Tool fixing devices

Tool spindles shall be provided with one of the following tool fixing devices:

- a) positive connection between the tool and the spindle;
- b) positive connection between the front flange or spindle ring (locking collar) and the spindle;
- c) cone connection.

See also [5.4.12](#).

Where saw flanges are provided, they shall conform to the following requirements:

- 1) the diameter of both flanges (or flange for flush mounted saw-blades) shall be at least  $D/6$  (where  $D$  is the diameter of the largest saw-blade for which the machine is designed);
- 2) for flanges other than those for flush mounted saw-blades, the clamping surface at the outside part of the flange shall be flat over a width of at least 3 mm and recessed to the centre. Both outside diameters shall be within a tolerance of  $\pm 1$  mm.

Hydrostatic tool fixing devices which are an integral part of the spindle or which are permanently connected with it shall have an additional mechanical device to prevent loosening of the tool in case of leakage in the hydrostatic system.

Tool release shall only be possible if the spindle is stopped and restart is prevented (this second requirement applies only when operator changes the tool manually).

The SRP/CS for interlocking between tool release and spindle standstill shall achieve at least PL = c or consist of two independent systems both achieving PL = b.

The SRP/CS for the prevention of unexpected start shall be at least PL = c

*Verification:* By checking the relevant drawings, inspection, measurement, and relevant functional testing of the machine.

#### 5.3.4 Braking

An automatic brake shall be provided for the following:

- a) tool spindles where the unbraked run-down time is more than 10 s. The braked run-down time shall be less than 10 s or where the run-up time exceeds 10 s shall be less than the run-up time but in no case exceed 30 s;
- b) sanding belt units where the unbraked run-down time is more than 30 s. The braked-run down time shall be less than 30 s.

In the case of a failure of the power supply, the run-down time may be exceeded when tool guards remain locked in close position (see [6.3](#)).

The SRP/CS for the braking control shall be at least PL = c

Where a spring operated mechanical brake or any other type of brake not using electronic components is fitted, the last paragraph of IEC 60204-1:2005, 9.3.4 does not apply.

For electrical braking controls, reverse current injection braking shall not be used.

As an exception where electric braking controls containing electronic components are used, the SRP/CS for braking shall achieve at least PL = b and be designed in category 2 of ISO 13849-1:2006 with the exception that the test rate requirement in ISO 13849-1:2006, 4.5.4 is not applicable. The SRP/CS for braking shall be tested periodically, e.g. by monitoring braked run down time. The feedback shall come from either the encoder fitted to the spindle motor or from the measurement of the residual current in the wires powering the motor. The test shall be

- a) independent from the basic control for braking or an internal watch dog shall be provided in the control for braking,
- b) independent from the intention of the operator, and
- c) performed at each spindle stop.

The diagnostic coverage ( $DC_{avg}$ ) shall be  $\geq 60\%$ .

NOTE 1 See ISO 13849-1:2006, Annex E for DC estimation.

A negative test shall be indicated. Where the test is negative more than three times in sequence, it shall not be possible to operate the machine.

As an exception, a simple electronic brake (using simple electronic parts like rectifiers, transistors, triacs, diodes, resistors, thyristors) shall achieve PL = b and PFHd according to ISO 13849-1 is less than  $3,8 \times 10^{-6}$ .

NOTE 2 Complex electronic components like microprocessors or PLCs cannot be considered as well tried under the scope of ISO 13849-1:2006 and therefore, do not fulfil the requirements of category 1.

NOTE 3 For calculating the probability of occurrence of a dangerous failure for a simple electronic brake component with no fault detection (no DC) and no testing capability (category 1), the procedure described in ISO 13849-1:2006, Annex D can be used.

*Verification:* For the determination of unbraked run-down time, run-up time, and braked run-down time, if relevant, see the appropriate tests given in [Annex A](#).

#### 5.3.5 Devices to minimize the possibility or the effect of ejection or kick-back

Means, e.g. deflectors, shall be fitted to move off-cuts away from the saw-blade in order to prevent them from coming into contact with the subsequent tools and being ejected from the machine or the off-cuts shall be hogged and extracted.

*Verification:* By checking the relevant drawings, inspection, and relevant functional testing of the machine.

For machines designed for banding solid wood edges in bars/laths/sticks (not rolled), where the milling units located after the gluing units (see [Figure 2](#), Key 6) are capable to work in climb cutting mode, a pressure device shall be fitted (e.g. pressure rollers) to prevent the solid edges being ejected from the machine.

If a pressure device incorporating pressure rollers is used, it shall meet the following requirements:

- a) it shall incorporate two rollers each having a surface (e.g. rubber) that will not damage the workpiece and shall press against its upper and lower faces and the banded solid edge;
- b) it shall incorporate one roller having a hard surface (e.g. steel) which shall press horizontally against the banded solid edge;
- c) it shall be installed on the machine between the outfeed end and the milling tools (see [Figure 4](#));
- d) the pressure exerted by the rollers described in a) shall be at least 50 N and be applied at right-angles to the upper and lower surfaces of the banded solid edge and for the roller described in b) shall be at least 300 N and be applied at right-angles to the banded solid edge.

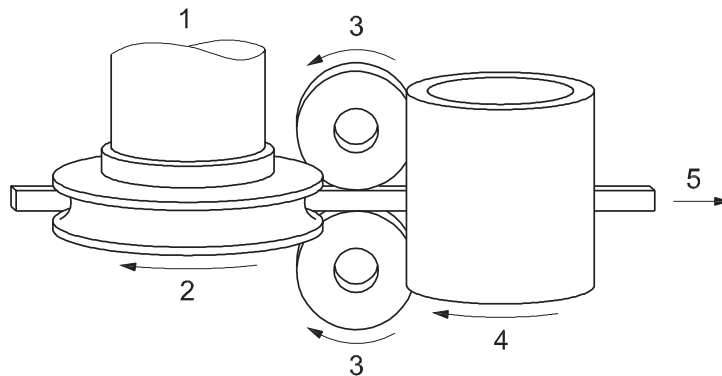

#### Key

- 1 motor
- 2 milling tool
- 3 soft-faced rollers (upper and lower)
- 4 solid roller
- 5 feed direction

**Figure 4 — Pressure device installation at the outfeed end of the machine**

If the milling unit is capable of cutting against the feed, a pressure device shall be fitted to prevent kick-back of the workpiece solid edge and be installed between the edge banding zone and the milling tools and unless kick-back is prevented by other means, e.g. the rollers assembly and the feeding system in the edge banding zone. If an additional pressure device is necessary, it shall meet the requirements of a), b), and d) above.

*Verification:* By checking the relevant drawings, inspection, and measurement.

### 5.3.6 Work-piece supports and guides

The work-piece shall be guided and supported by the chain beam and the top pressure beam.

A support for overhanging work-pieces shall be provided. Shearing or crushing hazards between the overhanging work-pieces and this support shall be minimized by positioning the bars or structure carrying this support at more than 120 mm below the top of the feed chain or workpiece support.

On machines fitted with an automatic panel returner, the following requirements apply (see [Figure 5](#)).

The access to the shearing and crushing points shall be prevented, e.g. by one or a combination of the following means:

- fixed guards with a minimum height of 1 800 mm and a maximum distance from the floor of 300 mm, laterally extending at least 850 mm beyond such points to prevent lateral access;
- where a workpiece support is equipped with a roller table, the gaps between the rollers shall be closed by fixed guards. The gaps between the rollers and the fixed guards and between the first and last rollers and fixed parts or belt conveyor shall be  $\leq 4$  mm. The fixed guards between the rollers shall have a maximum depth below the top of the rollers of 15 mm (see [Figure 6](#)).

The access to the hazardous points through the gap between the panel returner and the machine shall be prevented by, e.g. a horizontal fixed guard covering such gap or a combination of an AOPD of type 2 with at least two beams at the height of 300 mm and 800 mm above the floor level installed at the infed side and a fixed guard below the panel returner made in such a way that remaining gaps are not higher than 300 mm.

Dimensions in millimetres

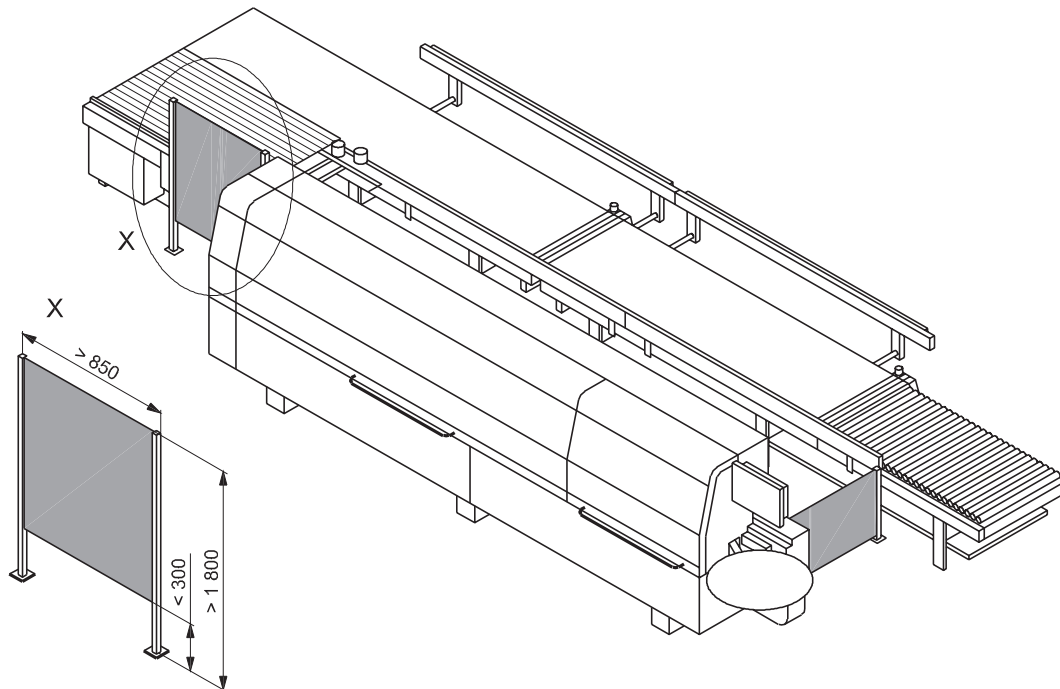
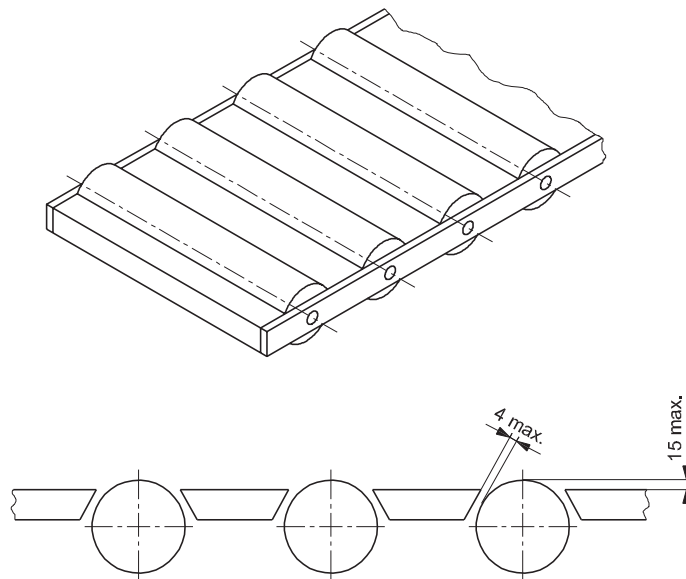

Figure 5 — Example of automatic panel returner

Dimensions in millimetres



**Figure 6 — Safeguarding of gaps between the rollers**

If used, the AOPD shall be in accordance with the requirements of IEC 61496-2 and its associated SRP/CS shall achieve at least PL = c. When the AOPD is triggered, the machine feed and any panel returner dangerous movement shall be stopped and power shall be cut to the relevant actuators. A manually operated reset control device for reactivating the AOPD shall be provided in such a position that it is not possible to get access to the reset control device from inside the protected zone and it is possible to have full view of the protected area from it. The SRP/CS for reset control shall achieve at least PL = c.

*Verification:* By checking the relevant drawings, inspection, and relevant functional testing of the machine.

### 5.3.7 Prevention of access to moving parts

#### 5.3.7.1 Guarding of tools

Access to the rotating tools, including sanding tools, shall be prevented by means of a guard or guards which make up an integral enclosure (also see 5.4.2), other than through the slot between the chain beam and top pressure beam (for such slot, see 5.3.7.7).

Where access is provided for maintenance, adjustment, or setting, this access shall be via a movable interlocking guard with guard locking in accordance with the requirements of ISO 14119:2013, F.5 (for the exceptions, see 5.2.6.2).

Where the run-down time of a tool exceeds 10 s, at least an interlocking device with spring applied/power released guard locking device in accordance with the requirements of ISO 14119:2013, F.1 to F.4 shall be used for that particular section of the enclosure.

The SRP/CS for the interlocking of tools drives with movable guards shall achieve at least PL = c.

*Verification:* By checking the relevant drawings and/or circuit diagrams, inspection, measurement, and relevant functional testing of the machine.

#### 5.3.7.2 Guarding of sanding belts

Access to the sanding belt, other than to that part necessarily exposed for sanding the work-piece, shall be prevented by fixed guards, in combination with a non-interlocking hinged cover, which is capable of being mechanically locked in the closed position during normal operation, for changing or adjusting the sanding belt, cleaning, or dust removal.

Fixed guards shall be provided to prevent shearing and crushing hazards between workpiece and external sanding unit.

Fixed guard shall be fitted with fixing systems attached to the guard or to the machine, e.g. un-losable screws, if they are demountable by the user, e.g. for maintenance, cleaning purposes, see 6.3 ee).

*Verification:* By checking the relevant drawings and/or circuit diagrams, inspection, and relevant functional testing of the machine.

### 5.3.7.3 Guarding of the edge banding zone

Access to snipping knives, spiked rollers, and pressure or loading rollers other than through the slot between the chain beam and the top pressure beam (for such slot, see 5.3.7.7) shall be prevented by means of fixed guards or movable guards interlocked or demountable guards interlocked with the corresponding drives in accordance with the requirements of ISO 14119:2013.

Fixed guard shall be fitted with fixing systems attached to the guard or to the machine, e.g. un-losable screws, if they are demountable by the user, e.g. for maintenance, cleaning purposes, see 6.3 ee).

When a demountable interlocked guard is provided, it shall not be possible to re-mount it in a wrong way.

Other hazards, e.g. trapping or crushing, shall be minimised by means of a deterring/impeding device preventing direct horizontal access.

The SRP/CS for interlocking tools drives with movable or demountable guards shall achieve at least PL = c.

*Verification:* By checking the relevant drawings, inspection, and relevant functional testing of the machine.

### 5.3.7.4 Guarding of the chain or other feed mechanisms

#### 5.3.7.4.1 General

Access to chains and pressure devices shall be prevented by the enclosure required by 5.3.7.1 and for such parts outside the enclosure by fixed guards except for that part of the chain and the pressure device necessarily exposed for holding and feeding the work-piece.

Fixed guard shall be fitted with fixing systems attached to the guard or to the machine, e.g. un-losable screws, if they are demountable by the user e.g. for maintenance, cleaning purposes, see 6.3 ee).

At the infeed end, outside the enclosure, the hazard of crushing between the closing pads of the chain shall be minimised by adequate design of the chain, e.g. by limiting opening between chain pads to 8 mm maximum where accessible, or provision of guarding (e.g. see Figure 7).

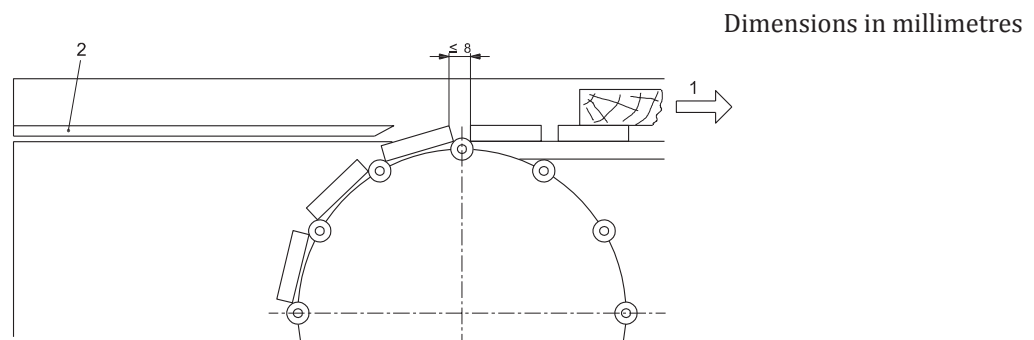

#### Key

- 1 feed direction
- 2 work-piece support

**Figure 7 — Example of adequate feed chain design**



At the outfeed end, the hazard of being drawn in between the chain and a fixed part of the machine shall be reduced by using a workpiece support or a suitable extension to the casing minimising the gap between it and the chain.

At the outfeed end, a fixed guard shall be provided to prevent direct access from above to the crushing and shearing points created by the workpiece and machine parts.

**Verification:** By checking the relevant drawings, inspection, measurement, and relevant functional testing of the machine.

#### 5.3.7.4.2 Trapping at the in feed end of the machine

Access to the trapping points of each top pressure beam shall be prevented by either of the following:

- a) fixed guard on each top pressure beam, which moves vertically with the top pressure beam. The gap between the top of the work-piece and this guard shall be  $\leq 4$  mm. In addition, a label shall be attached with a warning not to machine work-pieces with through-passing holes with diameter  $\geq 8$  mm, or
- b) mechanically actuated trip device (see [Figure 8](#)) in accordance with the requirements of IEC 13856-2, which SRP/CS shall achieve at least PL = c and which shall meet the following additional requirements:
  - 1) width of the sensor of each trip device shall extend at least over the full width of the beam;
  - 2) bottom edge of the trip device shall be no more than 8 mm above the surface of the work-piece during normal feeding;
  - 3) after engagement of the trip device, the stopping distance shall be short enough that a hand, resting on the work-piece and moving at the maximum feed speed, shall not reach the hazard point;
  - 4) trip device shall not in itself create a trapping hazard.

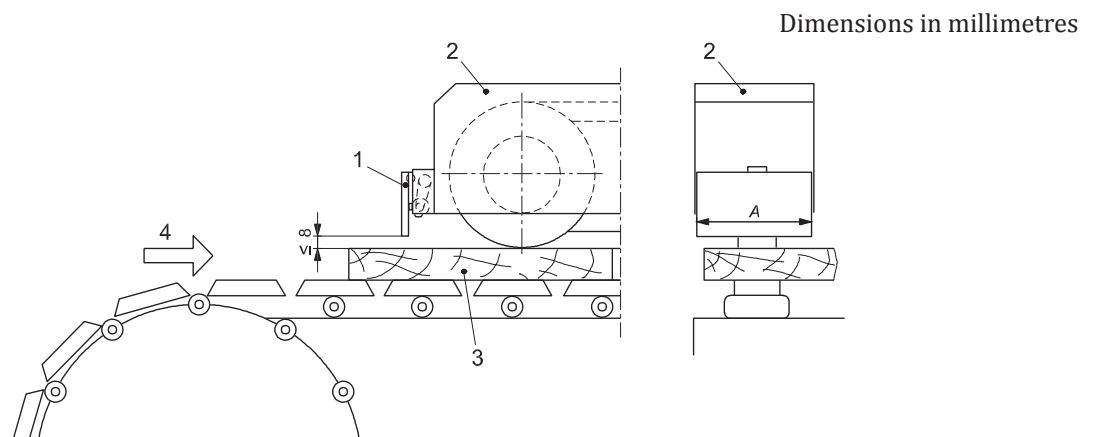

#### Key

- 1 trip device sensor
- 2 top pressure beam
- 3 work-piece
- 4 feed direction
- A width of sensor ( $A \geq$  width of top pressure beam)

**Figure 8 — Trip device at the infeed end of the machine**

**Verification:** By checking the relevant drawings and/or circuit diagrams, measurement, inspection, and relevant functional testing of the machine.



### 5.3.7.5 Safeguarding of machine half movement on double end machines

#### 5.3.7.5.1 Crushing between machine halves during closing movement

To prevent the hazard of being crushed between chain beams, the machine shall be fitted with either of the following:

- a) mechanically actuated trip device (see [Figure 9](#)) in accordance with the requirements of IEC 13856-2, which complies with the following four additional requirements:
  - 1) it shall extend at least over the full length of the chain beam;
  - 2) it shall have a maximum tripping force of 50 N;
  - 3) it shall be fitted to the moving chain beams and positioned such that its sensor is at least 50 mm in front of the chain beam and between 0 mm and 70 mm below the lowest crushing point of the chain beam;

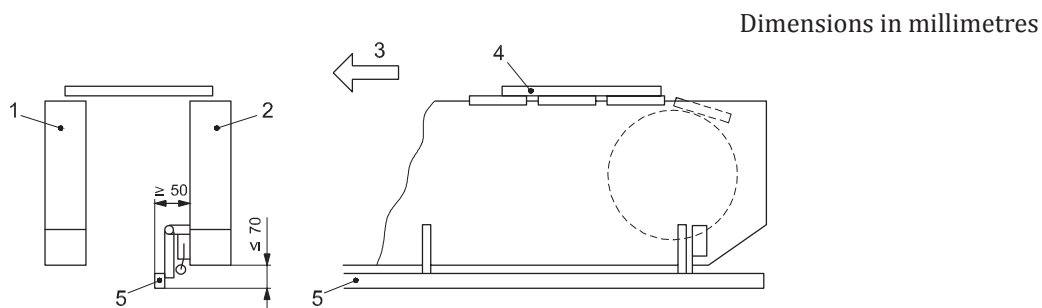

#### Key

- 1 fixed chain beam
- 2 moving chain beam
- 3 feed direction
- 4 work-piece
- 5 trip device sensor extending over full length of chain beam

**Figure 9 — Trip device on moving chain beam**

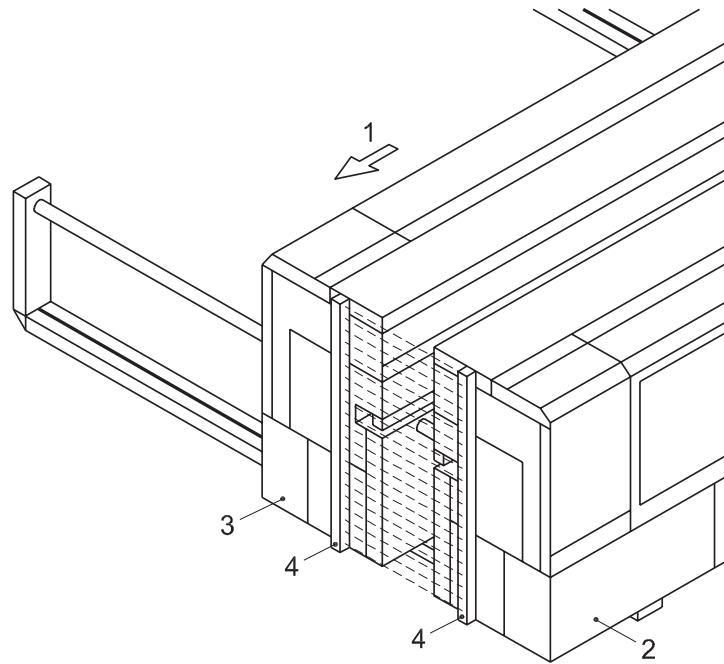

**Key**

- 1 feed direction
- 2 fixed half
- 3 movable half
- 4 AOPD

**Figure 10 — AOPD at the out-feed end**

- 4) when the trip device is triggered, the half shall stop before the trip device is fully compressed and power cut to the relevant actuator;

in combination with an AOPD of type 2 with a resolution not greater than 30 mm, placed over the full height of the internal edges of machine ends (see [Figure 10](#)); the AOPD shall be in accordance with the requirements of IEC 61496-2; when AOPD is triggered, the machine half shall stop and power shall be cut to the relevant actuator;

- b) AOPD (light barrier) in accordance with the requirements of IEC 61496-2. The light barrier shall have one or more beams which complies with a) 1) and a) 3) above. The residual stroke of the chain beam after actuation shall be  $\leq 50$  mm. This active opto-electronic protective device shall be at least type 2 in accordance with the requirements of IEC 61496-2;

in combination with an AOPD of type 2 with a resolution not greater than 30 mm, placed over the full height of the internal edges of machine ends (see [Figure 10](#)); the AOPD shall be in accordance with the requirements of IEC 61496-2; when AOPD is triggered, the machine half shall stop and power shall be cut to the relevant actuator;

- c) limiting device (see ISO 12100:2010, 3.26.8), which prevents the machine halves coming closer than 500 mm. In this case, the machine halves shall only be permitted to come closer than 500 mm by using a hold-to-run control device positioned so as to permit a clear view along the length of the machine halves;
- d) hold-to-run control device for the closing movement, positioned so as to permit a clear view along the length of the machine halves.

In a) and b), a reset control device shall be provided outside the danger zone and in a position from which there is good visibility for checking that no person is within the danger zone; the reset function

shall conform to the requirements of ISO 13849-1:2006, 5.2.2 and it shall be prevented to initiate the reset function when standing inside the safeguarded zone.

The SRP/CS for trip device, reset function, AOPD, hold-to-run function, and interlocking by limiting device shall achieve at least PL = c.

Where the distance between the chain beams is  $\geq 500$  mm or  $\leq 150$  mm, the device in longitudinal direction required in a) or b) can be overridden.

*Verification:* By checking the relevant drawings and/or circuit diagrams, measurement, inspection, and relevant functional testing of the machine.

#### **5.3.7.5.2 Crushing between machine halves and fixed parts of the machine during opening movement**

Where there is crushing/shearing hazard between fixed parts of the machine and the moving/opening of the machine halves, then one of the following measures, or a combination of them, shall be implemented:

- a) mechanically actuated trip device in accordance with the requirements in IEC 13856-2 shall be fitted, which SRP/CS shall achieve at least PL = c and which complies with the following additional requirements:
  - 1) it shall extend over at least the full length of the crushing area;
  - 2) it shall have a maximum tripping force of 50 N;
  - 3) when the trip device is triggered, the beam shall stop before the trip device is fully compressed;
- b) active opto-electronic protective device (light barrier) shall be fitted in accordance with the requirements of IEC 61496-2, which SRP/CS shall achieve at least PL = c. The light barrier shall have one or more beams which comply with the following additional requirements:
  - 1) it shall extend over at least the full length of the crushing area;
  - 2) it shall be so positioned that the sensor is at least 50 mm in front of the crushing area;
  - 3) the residual stroke after actuation shall be no more than 50 mm;
  - 4) it shall be at least type 2 of IEC 61496-2;
- c) hold-to-run control for the opening movement of the machine half, which SRP/CS shall achieve at least PL = c, shall be fitted and positioned such that the danger zone is visible;
- d) limiting device shall be fitted which prevents the machine half coming closer than 500 mm to a fixed part of the machine, further movement in the same direction shall only be possible by means of a hold-to-run control device positioned such that the danger zone is visible. The SRP/CS for interlocking by limiting device and hold-to-run control shall achieve at least PL = c.

In a) and b), a reset control device shall be provided outside the danger zone and in a position from which there is good visibility for checking that no person is within the danger zone; the reset function shall conform to the requirements of ISO 13849-1:2008, 5.2.2 and it shall be prevented to initiate the reset function when standing inside the safeguarded zone.

*Verification:* By checking the relevant drawings and/or circuit diagrams, measurement, inspection, and relevant functional testing of the machine.

#### **5.3.7.5.3 Impact with moving machine half**

Where the speed of a moving machine half exceeds  $25 \text{ m min}^{-1}$ , the impact hazard shall be minimised, e.g. by fitting a trip device or hold-to-run control device.

The SRP/CS for the trip device/hold-to-run function and for the reduced speed control for machine half movement shall achieve at least PL = c.

*Verification:* By checking the relevant drawings and/or circuit diagrams, inspection, measurement, and relevant functional testing of the machine.

#### 5.3.7.5.4 Access between the machine halves on double end machines

The machine shall be fitted with two active optoelectronic protective devices (light barriers) with at least two beams each, positioned at infeed and outfeed ends, in accordance with the requirements of IEC 61496-2 and with its associated safety-related control systems shall be at least PL = c in accordance with the requirements of ISO 13849-1:2006.

This active opto-electronic protective device shall be at least type 2 in accordance with the requirements of IEC 61496-2.

The devices shall

- a) activate a normal stop when actuated,
- b) extend across the full width of the opening between the chain beams,
- c) be positioned at a height of 400 mm above the floor level for the lower light beam and for the upper light beam at a height of 900 mm ± 100 mm above the floor level, and
- d) be positioned at a maximum distance of 1 m inside the machine ends edges.

Access between the machine halves from the lateral sides shall be prevented by fixed guards at a height not greater than 300 mm above the floor level, extending from the AOPD position.

*Verification:* By checking the relevant drawings and/or circuit diagrams, inspection, measurement, and relevant functional testing of the machine.

#### 5.3.7.6 Guarding of drives

Access to all drive mechanisms except the feed cross drive shaft shall be prevented by a fixed guard. Fixed guard shall be fitted with fixing systems attached to the guard or to the machine, e.g. un-losable screws if they are demountable by the user, e.g. for maintenance, cleaning purposes, see [6.3](#).

Where frequent access to these drives is provided for maintenance or adjustment purposes, i.e. more than once per week, access shall be via a movable interlocking guard. Where access to the tools is also possible, the movable guard shall be interlocked with guard locking in accordance with the requirements of [5.3.7.1](#).

The feed cross drive shaft (if any) shall be positioned at a vertical distance of at least 120 mm below the workpiece lower surface (see [Figure 11](#)).

*Verification:* By checking the relevant drawings and/or circuit diagrams, measurement, inspection, and relevant functional testing of the machine.

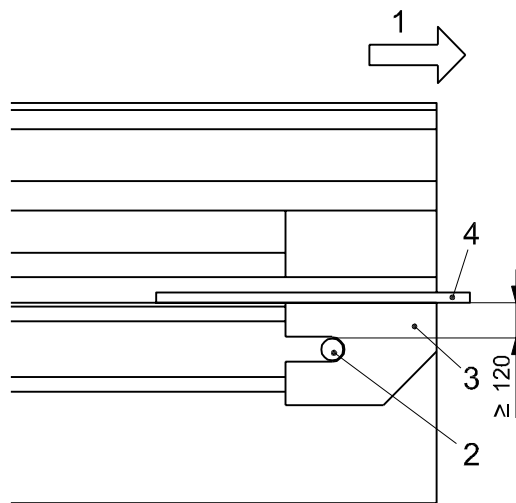

**Key**

- 1 feed direction
- 2 feed cross-drive shaft
- 3 workpiece support
- 4 workpiece

**Figure 11 — Feed cross drive shaft at machine out feed**

**5.3.7.7 Measures against access to hazard points through the slot between the chain beam and top pressure beam**

On double end machines the requirements of [5.3.7.1](#) and [5.3.7.2](#) apply.

On single end machines, (see also [6.2](#)) the slot between the chain beam and top pressure beam shall fulfil the following requirements:

- where the slot height is lower than or equal to 60 mm, a pictogram shall be affixed at the in-feed and out-feed ends of the top pressure beam and at 4 m pitch along the top pressure beam drawing attention to the residual risk;
- where the slot is higher than 60 mm, a pictogram shall be affixed at the in-feed and out-feed ends of the top pressure beam drawing attention to the residual risk and along the top pressure beam length, a safety horizontal distance of 1 m shall be kept perpendicular to the pressure beam direction by the deterring effect of the workpiece support.

*Verification:* By checking the relevant drawings and/or circuit diagrams, inspection, and relevant functional testing of the machine.

**5.4 Protection against non-mechanical hazards**

**5.4.1 Fire**

To minimize fire hazards, the requirements of [5.4.3](#) and [5.4.4](#) shall be fulfilled.

Overheating of a stationary work-piece or parts of the machine shall be avoided by interlocking the work-piece heaters (e.g. infrared lamps) with the feed.

The SRP/CS for the interlocking between heaters and feed shall achieve at least PL = c – or, as an exception for infrared lamps only, PL = b.

A flammable substance shall not be sprayed in an area at a temperature higher than the substance flash point. The SRP/CS for the interlocking between the flammable substance spray unit and the heat source shall achieve at least PL = c.

*Verification:* By checking the relevant drawings, and/or circuit diagrams, inspection, and relevant functional testing on the machine.

## 5.4.2 Noise

### 5.4.2.1 Noise reduction at the design stage

When designing machinery, the information and technical measures to control noise at source given in ISO 11688-1 shall be taken into account. The most relevant noise sources are the rotating tools.

The machine shall be provided with noise enclosure. If this noise enclosure is part of the guarding system, the interlocking and/or interlocking with guard locking shall fulfil the requirements in [5.3.7](#). If the noise enclosure is only effective for the noise hazards (i.e. there are other guards against the mechanical hazards), the noise enclosure need not be interlocked (see also [6.3](#)).

The enclosure should be lined with sound absorbing material, where possible. A lining material with a noise absorbing factor  $\alpha$  of 0,7 at 1 kHz measured in accordance with the requirements of ISO 354 can be used.

*Verification:* By checking the relevant drawings, measurement, inspection, and confirmation from the component manufacturers.

### 5.4.2.2 Noise emission measurement

Operating conditions for noise measurement shall comply with the requirements of ISO 7960:1995, Annex F or Annex G.

Mounting and operating conditions of the machine shall be identical for the determination of emission sound pressure levels at the work station and sound power levels.

Emission sound power levels shall be measured in accordance with the enveloping surface measuring method shown in ISO 3746:2010 with the following modifications:

- a) environmental indicator  $K_{2A}$  shall be equal to or less than 4 dB;
- b) difference between the background sound pressure level and the machine sound pressure level at each measuring point shall be equal to or greater than 6 dB. The correction formula for this difference is given in ISO 3746:2010, 8.3.3, Formula 12;
- c) only the parallelepiped measurement surface shall be used at 1 m from the reference surface;
- d) where the distance from the machine to an auxiliary unit is less than 2 m, the auxiliary unit shall be included in the reference surface;
- e) accuracy of the test method shall be better than 3 dB;
- f) number of microphone positions shall be nine in accordance with the requirements of ISO 7960:1995, Annex F or Annex G.

Alternatively, where the facilities exist and the measurement method applies to the machine type, emission sound power levels may also be measured in accordance with a method of higher precision, i.e. ISO 3743-1, ISO 3743-2, ISO 3744, and ISO 3745, without the preceding modifications.

For determination of sound power level by sound intensity method, use ISO 9614-1 (subject to agreement between the supplier and the purchaser).

Emission sound pressure level at the workstation shall be measured in accordance with the requirements of ISO 11202:2010 with the following modifications:

- 1) environmental indicator  $K_{2A}$  and local environmental factor  $K_{3A}$  shall be equal to or less than 4 dB;
- 2) difference between the background emission sound pressure level and the workstation sound pressure level shall be equal to or greater than 6 dB;
- 3) correction of the local environmental factor  $K_{3A}$  shall be calculated in accordance with the requirements of ISO 11204:2010, A.2 with reference restricted to ISO 3746:2010 instead of the method given in ISO 11202:2010, Annex A, or in accordance with ISO 3743-1, ISO 3743-2, ISO 3744, or ISO 3745 where one of these standards has been used as the measuring method.

For noise declaration, 6.3 aa) shall be met.

### 5.4.3 Emission of chips and dust

Provision shall be made for the extraction of dust and chips from the machine by providing outlets so as to enable the machine to be connected to the user's dust extraction system.

Unintended access to the tool through any dust extraction outlet with disconnected exhaust system shall be impeded.

The requirements of ISO 13857 shall not be applied here due to the negative impact on the extraction of chips and dust.

The opening of the capture device shall be large enough to capture the chips and dust projected.

NOTE 1 The size of the opening of the capture device depends on the emission pattern and the distance between the emission source and the opening of the capture device.

The capture device shall be designed in order to minimize pressure drop and material build up, e.g. by avoiding abrupt change of direction of extracted chips and dust, sharp angles, and obstacles causing a risk for hanging of chip and dust.

The conveying of chips and dust between the capture device and the machine connection to the Chips And Dust Extraction System (CADES), especially flexible connections of moving units, shall follow the requirements to minimize pressure drop and material build up.

To ensure that the chip and dust extracted during machining are conveyed to the collection system, the design of hoods, ducts, and baffles, etc. shall be based on a conveying velocity of extracted air in the duct of 20 m s<sup>-1</sup> for dry chips and 28 m s<sup>-1</sup> for wet chips (moisture content 18 % or above).

The pressure drop between the inlet of all capture devices and the connection to the CADES should be maximum 1,500 Pa (at 20 m s<sup>-1</sup> air flow rate).

**Verification:** By checking of drawings, visual inspection, and the following procedure:

- measure the pressure drop at the chosen air flow rate by measurement under the condition given for noise measurement in the relevant C-standard or ISO 7960;
- run the machine (without processing a work piece) under the conditions for noise measurement in the relevant C-standard or ISO 7960. The CADES shall be disconnected. Check if the machine creates an air flow from the inlets of the capture devices to the connection outlets to the CADES by use of smoke at the connection outlets.

NOTE 2 For measurement of chip and dust extraction system, performance two standardised methods are useful: concentration method (EN 1093-9+A1) and index method (EN 1093-11+A1).



#### 5.4.4 Electricity

With the exception of 6.3, the requirements of IEC 60204-1:2005 apply unless otherwise stated in this International Standard.

See IEC 60204-1:2005, 6.2 for the requirements regarding prevention of electric shock due to direct contact and IEC 60204-1:2005, Clause 7 for the requirements regarding protection against short circuits (feeder circuit excluded) and overloading.

The protection against electric shock due to indirect contact shall be ensured by the user, e.g. by automatic isolation of the electrical power supply of the machine by the operation of a protective device installed in the line powering the machine (see information provided by the manufacturer in the instruction handbook, 6.3 ff).

The protection against short circuits of the feeder circuit shall be ensured by the user (see the information provided by the manufacturer in the instruction handbook, 6.3 gg).

The degree of protection of all electric components out of the enclosures and the enclosures for electrical components itself/themselves shall be at least IP 54 in accordance with the requirements of IEC 60529+A1.

Electrical enclosures shall not be exposed to risk from ejection of tools and workpieces. Live parts shall not be accessible in accordance with IEC 60204-1:2005, 6.2.2. Fire risk is not present where power circuits are protected against over current in accordance with IEC 60204-1:2005, 7.2.2.

In accordance with IEC 60204-1:2005, 18.2 and 18.6, the test 1 for the continuity of the protective bonding circuit and functional tests apply.

Single phase motors with a rated input  $\leq 1$  kW manufactured in accordance with the requirements of EN 50144-1 may be used.

*Verification:* By checking the relevant drawings and/or circuit diagrams, inspection, and relevant tests (test 1 according to IEC 60204-1:2005, 18.2 and functional test according to IEC 60204-1:2005, 18.6).

NOTE For the components characteristics, confirmation from the components' manufacturers can be useful.

#### 5.4.5 Ergonomics and handling

The machine and its controls shall be designed according to ergonomic principles of EN 1005-4+A1 to enable work postures that are not fatiguing.

The height of the workpiece support should normally be between 800 mm and 1 100 mm above the floor level.

The positioning and labelling of control devices shall be in accordance with the ergonomic principles of EN 894-1+A1, EN 894-2+A1, EN 894-3+A1, EN 1005-1, EN 1005-2+A1, and EN 1005-3+A1.

Parts of the machine weighing more than 25 kg and that need to be replaced/removed shall be equipped with means for safe handling or enable safe lifting, such as attachments to accommodate the fitting of a lifting device in accordance with EN 1005-2+A1. These attachments shall be positioned such as to avoid machine or components overturn or fall or move in an uncontrolled way during transport, assembly, dismantling, disabling, and scrapping.

Tanks containing hydraulic fluid, compressed air drainers, and oilers shall be placed or oriented in such a way that the filler and drain pipes can be easily reached.

If the machine is fitted with a movable control panel, this panel shall be fitted with a facility to move it in the desired position.



If graphical symbols related to the operation of actuators are used, they shall be in accordance with IEC 61310-1:2007, Table A.1.

NOTE Useful information on ergonomics can also be found in IEC 60204-1:2005, EN 614-1:2006+A1:2009, EN 614-2:2000+A1:2009, and EN 1005-3:2002+A1:2008.

See also [5.2.2](#) and [6.3](#).

*Verification:* By checking the relevant drawings and/or circuit diagrams, measurements, and inspection of the machine.

#### 5.4.6 Lighting

Where lighting is required as determined by reference to EN 1837, it shall be provided in accordance with the requirements of IEC 60204-1:2005, 15.2.

See also [6.3](#).

*Verification:* By checking the relevant drawings and/or circuit diagrams and inspection of the machine.

#### 5.4.7 Pneumatics and hydraulics

See [5.2.1](#), [5.2.10](#), [5.4.10](#), [6.1](#), and [6.2](#). For pneumatics, see also [5.2.9](#), [5.3.3.4](#), [5.4.11](#), and ISO 4414:2010. For hydraulics, see also [5.3.3.6](#) and ISO 4413.

#### 5.4.8 Electromagnetic compatibility

The machine shall have sufficient immunity to electromagnetic disturbances to enable it to operate correctly in accordance with IEC 60439-1, EN 50370-1, and EN 50370-2.

NOTE Machines which incorporate CE-marked electrical components and where such components and cabling are installed in accordance with their respective manufacturers instructions, are generally considered to be protected against external electromagnetic interference.

*Verification:* By checking the relevant drawings and/or circuit diagrams and inspection of the machine.

#### 5.4.9 Static electricity

If the machine is fitted with flexible hoses for chip and dust extraction, the hoses shall be flame retardant. They shall also be antistatic or able to lead charge to earth potential via a metallic spiral. Both ends of this spiral shall be earthed.

*Verification:* By checking the relevant drawings and inspection of the machine.

#### 5.4.10 Isolation

The requirements of ISO 14118:2000, Clause 5 apply and in addition:

The electrical isolator shall be in accordance with the requirements of IEC 60204-1:2005, 5.3 except that the isolator shall not be of plug and socket type as described in IEC 60204-1:2005, 5.3.2.

If pneumatic energy is also used for other purposes than clamping, it shall be possible to isolate the pneumatic supply by a manually operated lockable mechanical valve according to ISO 4414:2010, 5.2.8, first indent. The device shall include means permitting it only to be locked in the off position (e.g. by a padlock). Dumping pneumatic pressure shall not be by disconnection of a pipe.

Where the machine has a hydraulic system, isolation of the hydraulic system shall be achieved either

a) by isolation of the electrical supply to the hydraulic drive motor (see IEC 60204-1:2005, 5.3), or

- b) by fitting a disconnection device, e.g. valve with mechanical locking in the off position (see also ISO 4414:2010).

*Verification:* By checking the relevant drawings and/or circuit diagrams, inspection, and relevant functional testing of the machine.

#### **5.4.11 Maintenance**

The basic principles of ISO 12100:2010, 6.2.15 shall be observed and, in addition, at least the information for maintenance listed in ISO 12100:2010, 6.4.5.1 e) shall be provided. See also [6.3](#).

Where residual energy is stored, e.g. in a reservoir or pipe, means for dumping residual pressure in a safe way shall be provided, for example using a valve. Dumping pressure shall not be by disconnection of a pipe.

*Verification:* By checking the relevant drawings, instruction handbook, inspection, and relevant functional testing of the machine.

#### **5.4.12 Errors of fitting**

It shall not be possible to fit a tool of greater diameter than the largest tool for which the machine is designed.

See also [5.4.14](#), [6.2](#), and [6.3](#).

*Verification:* By checking the relevant drawings and inspection of the machine.

#### **5.4.13 Heat**

Where there are hazards caused by contact of a hand with any hot surfaces, the requirements of ISO 13732-1:2006, 5.3 shall apply (where inadvertent contact means 1 s or less and voluntary contact, e.g. with a handle is more than 30 s). Contact shall be prevented by a fixed enclosing guard, constructed, e.g. of wire mesh with a mesh size of  $\leq 40$  mm or by insulating material.

This does not apply to the internal surfaces of the open glue-pot and glue-pot lid during filling.

*Verification:* By checking the relevant drawings, inspection and measurement of temperature.

#### **5.4.14 Substances**

See [5.4.3](#) and, in addition, provision shall be made to enable the gluing unit to be connected to an extraction system.

For glue, especially Polyurethane (PU) limit temperature, see [6.3](#) ii).

*Verification:* By checking the relevant drawings and visual inspection.

#### **5.4.15 Artificial optical radiation**

Where heating lamps are provided, the machine shall be designed to minimize the spread and reflection of their radiation.

## **6 Information for use**

### **6.1 Warning devices**

A pictogram or written warning shall be permanently affixed to the machine stating that the top pressure beam and the pressure devices required in [5.3.5](#) shall be correctly adjusted to accommodate the work-piece to be machined.

On single end machines, a pictogram shall be affixed drawing attention to the residual risk as required in [5.3.7.7](#).

If the machine is equipped with a pneumatic/hydraulic supply, a permanent warning label shall be placed in proximity to the electrical supply disconnection device warning that the pneumatic supply is not isolated by isolation of the electrical supply.

The warnings shall either be in the language of the country in which the machine is to be used or wherever possible by using pictograms.

*Verification:* By checking the relevant drawings, measurement, and inspection on the machine.

## 6.2 Marking

The principles of ISO 12100:2010, 6.4.4 shall be observed and in addition:

The following information shall be marked legibly and indelibly throughout the expected life of the machine either directly on the machine (e.g. by engraving, etching, or using labels or stickers) or a plate permanently affixed to the machine (e.g. by riveting):

- a) business name and address of the machine manufacturer and, where applicable, of his authorized representative;
- b) year of construction, that is the year in which the manufacturing process is completed;
- c) designation of the machinery and designation of series or type;
- d) machine identification or serial number (if any);
- e) rating information (mandatory for electro-technical products: voltage, frequency, nominal current);
- f) label or pictogram adjacent to any speed changing device or on a door giving access to the belt drive mechanism indicating the operating speed of each spindle. This information shall, where relevant, indicate the speed at each position of the control device or pulley diameter;
- g) label at the infeed warning to take care when machining workpieces with holes with diameter  $\geq 8$  mm if no trip device is provided at the infeed side as per [5.3.7.4.2 b\)](#);
- h) where the machine is fitted with a hydraulic and/or pneumatic system with nominal pressure for the hydraulic and/or pneumatic circuits;
- i) where the machine is fitted with hydraulic and/or pneumatic isolators their function, location and operational positions e.g. by a label or a pictogram;
- j) an arrow for spindles rotating in clockwise direction and double arrow for spindles which can rotate in both direction of rotation;
- k) when using PU glue, a warning not to exceed its limit temperature, placed at the heating system manual control or scale or given by its electronic control;
- l) where the machine is fitted with heating lamps, a warning symbol for artificial optical radiation (AOR) according to EN 12198.

The labels or pictograms for marking the nominal pressure and the isolators shall be fitted in a position in close proximity to the installed location of the isolators on the machine.

The warnings shall either be in the language of the country in which the machine is to be used or, wherever possible, by using pictograms.

*Verification:* By checking the relevant drawings and inspection on the machine.

### 6.3 Instruction handbook

The principles of ISO 12100:2010, 6.4.5 shall be observed and, in addition, the instruction handbook shall include at least the following:

- a) repetition of the markings, pictograms, and other instructions on the machine (see [6.1](#) and [6.2](#)) and, if necessary, information about their meaning;
- b) intended use of the machine including reasonably foreseeable misuse, e.g. machining sparks generating metals, materials of edging tapes;
- c) warning regarding residual risk (e.g. ejection, indication that in case of power supply failure tool can run for more than 10 s);
- d) instructions for the safe use [see also ISO 12100:2010, 6.4.5.1 d)], these include instructions on how the following points can be satisfied:
  - 1) floor area around the machine to be level, well maintained, and free from loose material (e.g. chips and off-cuts);
  - 2) wear of suitable personal protective equipment, when necessary; this may include the following:
    - i) hearing protection to reduce the risk of induced hearing loss;
    - ii) respiratory protection to reduce the risk of inhalation of harmful dust and gases;
    - iii) gloves for handling saw tools (tools should be carried in a holder, wherever practicable);
  - 3) to stop the machine running while unattended;
  - 4) to report faults in the machine, including guards or tools, as soon as they are discovered;
  - 5) to adopt safe procedures for cleaning, maintenance, and remove chips and dust regularly to avoid the risk of fire;
  - 6) to ensure that any spacers and saw flanges used are suitable for the purpose as stated by the manufacturer (see [5.3.3.6](#));
  - 7) to refrain from removing any off-cut or other part of the workpiece from the cutting area while the machine is running;
  - 8) to ensure that guards and other safety devices necessary for machine operation are in position, in good working order, and properly maintained;
- e) where necessary on stationary machines, requirements for the need to fix the machine to the floor and how this is to be done;
- f) information that at the out feed end of the machine a minimum free space of 500 mm more than the maximum length of the work-piece to be machined shall be ensured;
- g) on single end machines, information that at the side of the panel support a minimum free space of 500 mm more than the maximum width of the work-piece to be machined shall be ensured;
- h) on double end machines, information that at the side of the moving machine half a minimum free space of 500 mm between the moving machine half and other fixed adjacent machines, part of the building or stocks of material, etc. shall be ensured, when crushing/shearing hazard is not prevented by measures given in [5.3.7.5.2](#);
- i) on displaceable machines, information how transportation shall be handled and how to make the machine stable during machining;
- j) the range of saw-blade and milling tool diameters and thickness which are suitable for the machine;

- k) instruction that only sharpened saw-blades and milling tools manufactured in accordance with the requirements of EN 847-1:2013 shall be used;
- l) information that operators are adequately trained in the adjustment and operation of the machine, including the correct use;
- m) instruction that adequate general or localized lighting shall be provided;
- n) where relevant, information on how to avoid contact between the tools which are adjusted manually and other parts of the machine;
- o) where relevant, information to avoid rising up the feed mechanism while tools are rotating and workpieces or parts of it are still in the machine; on machines with automatic height adjustment, when rising of the feed mechanism is impeded, a message shall be given for the operator to check for presence of workpieces;
- p) where relevant, information on how to avoid contact between the tools and other parts of the machine during powered adjustment of the spindles, e.g. the correct positioning of the manually adjustable mechanical restraint device or by validating the operation of the relevant work programme in the numeric control system;
- q) instruction that where the noise enclosure is not interlocked (see [5.4.2.1](#)), the noise enclosures shall remain in the closed position as long as possible to ensure the most efficient noise reduction;
- r) information that during use, the machine shall be connected to external extraction systems;  
NOTE External CADES with fixed installations are dealt with in EN 12779+A1.
- s) information regarding the chip and dust equipment fitted to the machine as follows:
  - 1) necessary airflow in  $\text{m}^3 \text{h}^{-1}$ ;
  - 2) pressure drop at each dust extraction connection outlet;
  - 3) recommended conveying air velocity in the duct in  $\text{m s}^{-1}$ ;
  - 4) cross section dimensions and details of each connection outlet;
- t) instruction that extraction systems shall be switched on before commencing machining;
- u) information that the gluing unit when using PU glue shall be connected to a dedicated extraction system, separate from the CADES;
- v) information that, whenever possible, maintenance shall be only done if the machine is isolated from all energy sources and involuntary restart is prevented;
- w) information that before changing any tool, the machine shall be isolated or disconnected from its electrical power supply;
- x) information about safe cleaning;
- y) if fitted with a hydraulic or a pneumatic system, the method for the safe dissipation of residual energy (see [5.4.15](#));
- z) those safety devices which shall be tested, how frequently the tests shall be carried out and the test method. This shall include at least the following:
  - 1) emergency stops by functional test;
  - 2) interlocking guards by opening each guard in turn to stop the machine and by proving the inability to start the machine with each guard in the open position;
  - 3) any trip devices by functional test;

- 4) the brakes by functional test to check that the machine is braked within the specified time;
  - 5) any pressure device by functional test;
  - 6) Interlocking of guards with guard locking by functional test;
  - 7) Any AOPD by functional test;
- aa) declaration of airborne noise emission by the machinery, either the actual value or a value established on the basis of measurements made on identical machinery, measured in accordance with the methods given in [5.4.2.2](#).
- 1) A-weighted emission sound pressure levels at workstations;
  - 2) A-weighted sound power level emitted by the machinery.

In the case of very large machinery (i.e. machines with at least one dimension exceeding 7 m), instead of the sound power level, the emission sound pressure levels at specified positions around the machinery may be indicated.

The declaration shall be accompanied by a statement of the measuring method used and the operating conditions applied during the test and values for associated uncertainty  $K$  using the dual-number form of declaration according to ISO 4871 as follows:

4 dB when using ISO 3746:2010 and ISO 11202:2010;

2 dB when using ISO 3743-1:2010 or ISO 3743-2:2009 or ISO 3744;

1 dB when using ISO 3745

for example, for a sound power level:  $L_{WA} = xx$  dB (measured value)

Associated uncertainty  $K = 4$  dB

Measurement made in accordance with ISO 3746:2010.

If the accuracy of the declared emission values is to be checked, measurements shall be made using the same method and the same operating conditions as those declared.

The noise declaration shall be accompanied by the following statement:

"The figures quoted are emission levels and are not necessarily safe working levels. While there is a correlation between the emission and exposure levels, this cannot be used reliably to determine whether or not further precautions are required. Factors that influence the actual level of exposure of the workforce includes the characteristics of the work room and the other sources of noise, etc. (i.e. the number of machines and other adjacent processes). Also, the permissible exposure level can vary from country to country. This information, however, will enable the user of the machine to make a better evaluation of the hazard and risk."

Information on noise emission shall also be provided in the sales literature when performance data are provided.

- bb) information on conditions necessary to ensure that throughout the foreseeable lifetime, the machine, including its components, cannot overturn or fall or move in an uncontrolled way during transport, assembly, dismantling, disabling, and scrapping;
- cc) the operating method to be followed in the event of accident or breakdown; if a blockage is likely to occur, the operating method to be followed so as to enable the equipment to be safely unblocked;
- dd) the identification data of the spare parts to be changed by the user when these affect the health and safety of operators (parts to be dismantled only by the manufacturer or authorized personal designated by the manufacturer are excluded);

- ee) description of fixed guards which have to be removed by the user for maintenance and cleaning purposes (guards to be dismantled only by the manufacturer or authorized personal designated by the manufacturer are excluded);
- ff) information on how to provide protection of people against electrical shock due to indirect contact in the machine by a device for automatic disconnection of the power supply to be installed by the user in the line powering the machine (RCD);
- gg) information on how to provide protection against short circuits of the feeder circuit;
- hh) for machines equipped with hydrostatic tool fixing facilities, only tool fixing devices with additional mechanical device to protect against loosening of the tool in case of leakage in the hydrostatic system shall be used;
- ii) when using PU glue, explanation that its limit temperature shall not be exceeded because it generates carcinogenic substances;
- jj) where tele-control is provided, information that it shall only be activated with the machine operator present at the machine.

Verification: By checking the instruction handbook and relevant drawings.



## Annex A (normative)

### Braking tests

#### A.1 Conditions for brake tests

- a) The spindle unit shall be set in accordance with the intended use of the machine (e.g. for belt tension). See 6.3 b).
- b) When selecting the speed and the tools, conditions shall be chosen which create the greatest kinetic energy for which the machine is designed (the selection to take into account are tool sizes, types, spindle speed, etc.).
- c) Before beginning the test, the spindle unit shall be running for at least 15 min at no load (idle speed).
- d) Verify that the actual spindle speed is within 10 % of the intended speed.
- e) The speed measuring equipment shall have an accuracy  $\leq 1$  % of full scale.
- f) The time measuring equipment shall have an accuracy  $\leq 0,1$  s.

#### A.2 Tests

##### A.2.1 Unbraked run-down time

The unbraked run-down time shall be measured as follows:

- a) initiate spindle stop and measure the unbraked run-down time;
- b) restart the spindle drive motor and allow it to reach the intended speed;
- c) repeat steps a) and b) twice more.

The unbraked run-down time is the average of the three measurements taken.

##### A.2.2 Braked run-down time

The braked run-down time shall be measured as follows:

- a) initiate braking and measure the braked run-down time;
- b) allow the spindle to remain stationary for  $\left(\frac{P}{7,5}\right)^2$  min where  $P$  is the motor power in kW;
- c) restart the spindle drive motor and run at no load for  $\left(\frac{P}{7,5}\right)^2$  min;
- d) repeat steps a) to c) nine times.

The braked run-down time is the average of the ten measurements taken.



### A.2.3 Run-up time

The run-up time shall be measured as follows:

- a) start the tool spindle drive motor and measure the run-up time (see [3.8](#));
- b) cut power to the tool spindle drive motor and allow the spindle to come to a complete stop;
- c) repeat steps a) and b) twice more.

The run-up time is the average of the three measurements taken.

## Annex B (normative)

### Impact test method for guards

#### B.1 General

This Annex defines tests for rigid guards used on edge banding machines in order to minimize risks of ejection of parts of tools or of workpieces out of the working zone.

This test reproduces the hazard of the ejection of tools parts or of work-pieces and allows estimation of the resistance of guards against penetration and dislodgement from the machine by ejected parts from machine or work-piece.

This Annex applies to guards as well as on samples of guard materials.

#### B.2 Test equipment

The test equipment comprises a propulsion device, a projectile, a support for the test object, and a system that allows to measure or record the impact speed with an accuracy of at least  $\pm 5\%$ .

As an example, the propulsion device may consist of a compressed air vessel with flanged gun barrel (see [Figure B.1](#)). The compressed air may be released by a valve to accelerate the projectile toward the test object. The air gun is fed by an air compressor. The speed of the projectile may be controlled by the pressure of the air.

The projectile speed is measured near the nozzle of the gun barrel by a suitable speedometer, e.g. by proximity sensor or photocell.

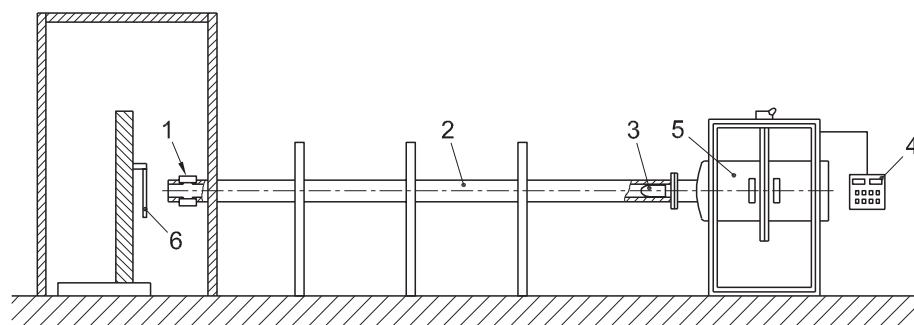

#### Key

- 1 speedometer
- 2 gun barrel
- 3 projectile
- 4 control panel
- 5 compressed-air vessel
- 6 test object

**Figure B.1 — Example of equipment for impact test**

### B.3 Projectile

The shape, mass, and dimensions of projectile are given in [Figure B.2](#).

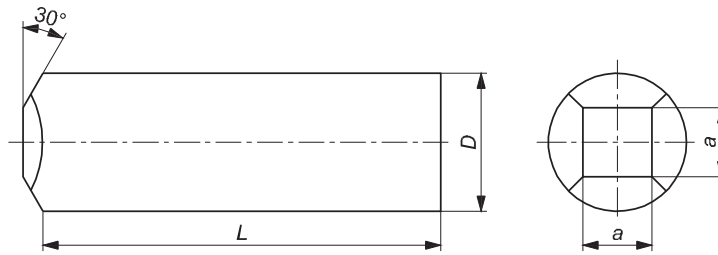

#### Key

- a 10 mm
- D 20 mm
- Mass 100 g

**Figure B.2 — Projectile for rigid guard test**

The projectile shall be made from steel with the following characteristics:

- a) tensile strength:  $R_m = 560 \text{ N mm}^{-2}$  to  $690 \text{ N mm}^{-2}$ ;
- b) yield strength:  $R_{0,2} \geq 330 \text{ N mm}^{-2}$ ;
- c) elongation at rupture:  $A \geq 20 \%$ ;
- d) hardened to  $56_{0}^{+4}$  HRC over depth of at least 0,5 mm.

### B.4 Sampling

The test is carried out with the guard or a sample of the guard material. The guard support shall be equivalent to the guard mounting on the machine. For testing guard materials, samples may be used, fixed on a frame with an inner opening of 450 mm × 450 mm. The frame shall be sufficiently rigid. The mounting of the sample shall be by non-positive clamping.

### B.5 Test procedure

For machines equipped with milling cutters, the impact test shall be executed with projectile indicated in [B.3](#) and an impact speed of  $70 \text{ m s}^{-1} \pm 3,5 \text{ m s}^{-1}$ .

Impact shall be as square to the material sample surface or the guard surface as possible. The targets for the projectiles shall be the weakest and most unfavourable spot on the guard and centre of the material sample.

### B.6 Results

After the impact, damages found on the guard or material shall be assessed as follows:

- a) buckling/bulging (permanent deformation without crack);
- b) incipient crack (visible only on one surface);
- c) through crack (crack visible from one surface to the other);
- d) penetration (projectile penetrating the test object);

- e) guard window loosened from its fixing;
- f) guard loosened from guard support.

### **B.7 Assessment**

The test is passed if there is no through crack or penetrations of the test object and if there are no damages e) and f) in accordance with the requirements of [B.6](#).

### **B.8 Test report**

The test report shall give the following minimum information:

- a) date, place of the test, and name of the testing institute;
- b) projectile mass, dimensions, speed;
- c) applicant identification;
- d) design, material, and dimensions of the test object;
- e) clamping or fixing of the test object;
- f) direction of shock, point of impact of the projectile;
- g) test result.

## Annex C (normative)

### Stability test for displaceable machines

#### C.1 Test of stability during machining

The machine shall be set in its working position on a chipboard fixed on the floor and the brakes for the wheels applied (where fitted) or the wheels retracted from the floor (if a device for retracting them is fitted). A horizontal force  $F_1 = 100$  N shall be applied in the plane of work-piece support and in the direction of feed in line with the machine tool. Subsequently, a horizontal force  $F_1 = 100$  N is applied in the same plane but in perpendicular direction in the middle of the machine. Under both conditions, the machine shall not move.

The test is repeated with a horizontal force  $F_2 = 300$  N. The machine shall not tilt.

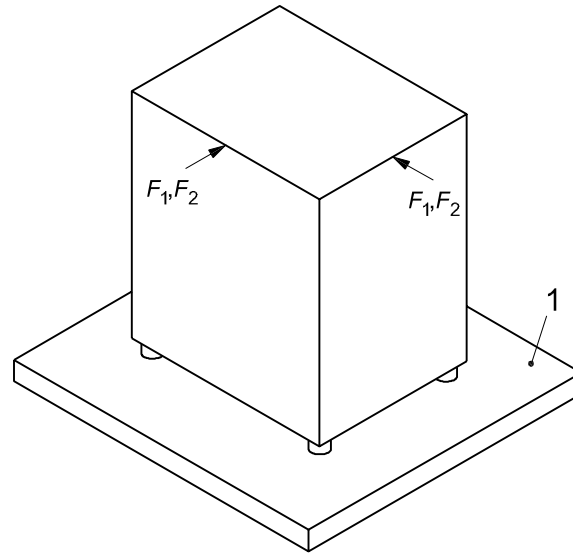

#### Key

1 chipboard

Figure C.1 — Stability test for displaceable machines

#### C.2 Test of stability during transportation

The machine is held in its normal transportation position on a plane inclined at an angle of  $10^\circ$  to the horizontal, the cable or cord wrapped up and stored.

While the machine is rotated slowly through  $360^\circ$ , it shall not tip over.

## Annex D (informative)

### Performance level required

This Annex gives a summarizing table of PL<sub>r</sub> for each safety function to show them at a glance without browsing the whole document. However, [Clause 5](#) subclauses text remains the sole proper normative reference for the full requirements and explanations, which might not be summarized enough to fit in [Table D.1](#).

**Table D.1 — Safety functions and Performance Level (PL) required**

Area	Safety function		PL <sub>r</sub>	Clause of ISO 18217
Starting	1	Power-on control	c	<a href="#">5.2.3</a>
	2	Starting of spindle drives and feed drives	b	<a href="#">5.2.3</a>
	3	Prevention of unexpected start after power supply restoration	c	<a href="#">5.2.8</a>
Stopping	4	Initiation of normal stop	c	<a href="#">5.2.4.1</a>
	5	Delayed power cut to the brake by time delay device	c	<a href="#">5.2.4.1</a>
	6	Standstill monitoring during operational stop	c	<a href="#">5.2.4.2</a>
	7	Initiation of emergency stop	c	<a href="#">5.2.4.3</a>
Integrated feed	8	Interlocking of feed start with spindle tool drive motor	b	<a href="#">5.2.5.1</a>
	9	Interlocking of feed start with spindle retraction	b	<a href="#">5.2.5.2</a>
	10	Interlocking of automatic height adjustment with work-piece detection	b	<a href="#">5.2.5.3</a>
Mode selection	11	mode selection control	c	<a href="#">5.2.6.1</a>
	12	Hold-to-Run control for movement of feed and powered adjustments	c	<a href="#">5.2.6.2</a>
	13	Hold-to-Run control for movement of feed and powered adjustments with adjacent emergency stop control device	b	<a href="#">5.2.6.2</a>
	14	Control for postponement of interlocking with doors open	c	<a href="#">5.2.6.3</a>
	15	Interlocking of dynamic processing units with moveable guards	c	<a href="#">5.2.6.3</a>
Spindle variable speed	16	Overspeed control	c	<a href="#">5.2.7</a>
Tool fixing	17	Interlocking of tool release with spindle standstill	c	<a href="#">5.3.3.6</a>
	18	Interlocking of tool release with prevention of unexpected start (for manual tool change only)	c	<a href="#">5.3.3.6</a>
Braking	19	Braking control	b/c	<a href="#">5.3.4</a>
Guarding, Safe-guarding	20	Reset control for AOPD and for trip device	c	<a href="#">5.3.6</a> , <a href="#">5.3.7.5.1</a> , <a href="#">5.3.7.5.2</a> , <a href="#">5.3.7.5.4</a>
	21	interlocking of tools drives with movable or dismountable guards	c	<a href="#">5.3.7.1</a> , <a href="#">5.3.7.3</a> , <a href="#">5.3.7.6</a>
	22	control for trip device	c	<a href="#">5.3.7.4.2</a>

**Table D.1** (continued)

Area	Safety function		PL <sub>r</sub>	Clause of ISO 18217
	23	For double end machines: control for trip device, reset, AOPD, hold-to-run and interlocking by limiting device, reduced speed	c	<a href="#">5.3.7.5.1</a> , <a href="#">5.3.7.5.2</a> , <a href="#">5.3.7.5.3</a>
Heaters	24	Interlocking between heaters and feed	c	<a href="#">5.4.1</a>
	25	Interlocking between infrared heaters and feed	b	<a href="#">5.4.1</a>
	26	Interlocking between flammable substance spray unit and temperature of the heat source	c	<a href="#">5.4.1</a>

## Bibliography

- [1] EN 614-1+A1, *Safety of machinery — Ergonomic design principles — Part 1: Terminology and general principles*
- [2] EN 847-1:2013, *Tools for woodworking — Safety requirements — Part 1: Milling tools, circular saw blades*
- [3] EN 894-1+A1, *Safety of machinery — Ergonomics requirements for the design of displays and control actuators — Part 1: General principles for human interactions with displays and control actuators*
- [4] EN 894-2+A1, *Safety of machinery — Ergonomics requirements for the design of displays and control actuators — Part 2: Displays*
- [5] EN 894-3+A1, *Safety of machinery — Ergonomics requirements for the design of displays and control actuators — Part 3: Control actuators*
- [6] EN 1005-1+A1, *Safety of machinery — Human physical performance — Part 1: Terms and definitions*
- [7] EN 1005-2+A1, *Safety of machinery — Human physical performance — Part 2: Manual handling of machinery and component parts of machinery*
- [8] EN 1005-3+A1, *Safety of machinery — Human physical performance — Part 3: Recommended force limits for machinery operation*
- [9] EN 1005-4+A1, *Safety of machinery — Human physical performance — Part 4: Evaluation of working postures and movements in relation to machinery*
- [10] EN 1093-9+A1, *Safety of machinery — Evaluation of the emission of airborne hazardous substances — Part 9: Pollutant concentration parameter, room method*
- [11] EN 1093-11+A1, *Safety of machinery — Evaluation of the emission of airborne hazardous substances — Part 11: Decontamination index*
- [12] EN 1837, *Safety of machinery — Integral lighting of machines*
- [13] EN 12779+A1, *Safety of woodworking machines — Chip and dust extraction systems with fixed installation — Safety-related performances and safety requirements*
- [14] EN 50144-1, *Safety of hand-held electric motor operated tools — Part 1: General requirements*
- [15] EN 50525-1, *Electric cables — Low voltage energy cables of rated voltages up to and including 450/750 V (U0/U) — Part 1: General requirements*
- [16] EN 50525-2-11, *Electric cables — Low voltage energy cables of rated voltages up to and including 450/750 V (U0/U) — Part 2-11: Cables for general applications — Flexible cables with thermoplastic PVC insulation*
- [17] EN 50525-2-21, *Electric cables — Low voltage energy cables of rated voltages up to and including 450/750 V (U0/U) — Part 2-21: Cables for general applications — Flexible cables with crosslinked elastomeric insulation*
- [18] ISO 286-2, *ISO system of limits and fits — Part 2: Tables of standard tolerance grades and limit deviations for holes and shafts*
- [19] ISO 354, *Acoustics — Measurement of sound absorption in a reverberation room*
- [20] ISO 3743-1, *Acoustics — Determination of sound power levels and sound energy levels of noise sources using sound pressure — Engineering methods for small movable sources in reverberant fields — Part 1: Comparison method for a hard-walled test room*



- [21] ISO 3743-2, *Acoustics — Determination of sound power levels of noise sources using sound pressure — Engineering methods for small, movable sources in reverberant fields — Part 2: Methods for special reverberation test rooms*
- [22] ISO 3744, *Acoustics — Determination of sound power levels and sound energy levels of noise sources using sound pressure — Engineering methods for an essentially free field over a reflecting plane*
- [23] ISO 3745, *Acoustics — Determination of sound power levels and sound energy levels of noise sources using sound pressure — Precision methods for anechoic rooms and hemi-anechoic rooms*
- [24] ISO 4871, *Acoustics — Declaration and verification of noise emission values of machinery and equipment*
- [25] ISO 9614-1, *Acoustics — Determination of sound power levels of noise sources using sound intensity — Part 1: Measurement at discrete points*
- [26] ISO 11202:2010, *Acoustics — Noise emitted by machinery and equipment — Determination of emission sound pressure levels at a work station and at other specified positions applying approximate environmental corrections*
- [27] ISO 11204:2010, *Acoustics — Noise emitted by machinery and equipment — Determination of emission sound pressure levels at a work station and at other specified positions applying accurate environmental corrections*
- [28] ISO/TR 11688-1, *Acoustics — Recommended practice for the design of low-noise machinery and equipment — Part 1: Planning*
- [29] ISO/TR 11688-2, *Acoustics — Recommended practice for the design of low-noise machinery and equipment — Part 2: Introduction to the physics of low-noise design*
- [30] IEC 60947-4-1, *Low-voltage switchgear and controlgear — Part 4-1: Contactors and motor-starters — Electromechanical contactors and motor-starters*
- [31] IEC 60947-5-1, *Low-voltage switchgear and controlgear — Part 5-1: Control circuit devices and switching elements — Electromechanical control circuit devices*
- [32] IEC 61508-1+Corrigendum, *Functional safety of electrical/electronic/programmable electronic safety-related systems — Part 1: General requirements*
- [33] IEC 61508-2, *Functional safety of electrical/electronic/programmable electronic safety-related systems — Part 2: Requirements for electrical/electronic/programmable electronic safety-related systems*
- [34] IEC 61508-4+Corrigendum, *Functional safety of electrical/electronic/programmable electronic safety-related systems — Part 4: Definitions and abbreviations*





# British Standards Institution (BSI)

BSI is the national body responsible for preparing British Standards and other standards-related publications, information and services.

BSI is incorporated by Royal Charter. British Standards and other standardization products are published by BSI Standards Limited.

## About us

We bring together business, industry, government, consumers, innovators and others to shape their combined experience and expertise into standards-based solutions.

The knowledge embodied in our standards has been carefully assembled in a dependable format and refined through our open consultation process. Organizations of all sizes and across all sectors choose standards to help them achieve their goals.

## Information on standards

We can provide you with the knowledge that your organization needs to succeed. Find out more about British Standards by visiting our website at [bsigroup.com/standards](http://bsigroup.com/standards) or contacting our Customer Services team or Knowledge Centre.

## Buying standards

You can buy and download PDF versions of BSI publications, including British and adopted European and international standards, through our website at [bsigroup.com/shop](http://bsigroup.com/shop), where hard copies can also be purchased.

If you need international and foreign standards from other Standards Development Organizations, hard copies can be ordered from our Customer Services team.

## Subscriptions

Our range of subscription services are designed to make using standards easier for you. For further information on our subscription products go to [bsigroup.com/subscriptions](http://bsigroup.com/subscriptions).

With **British Standards Online (BSOL)** you'll have instant access to over 55,000 British and adopted European and international standards from your desktop. It's available 24/7 and is refreshed daily so you'll always be up to date.

You can keep in touch with standards developments and receive substantial discounts on the purchase price of standards, both in single copy and subscription format, by becoming a **BSI Subscribing Member**.

**PLUS** is an updating service exclusive to BSI Subscribing Members. You will automatically receive the latest hard copy of your standards when they're revised or replaced.

To find out more about becoming a BSI Subscribing Member and the benefits of membership, please visit [bsigroup.com/shop](http://bsigroup.com/shop).

With a **Multi-User Network Licence (MUNL)** you are able to host standards publications on your intranet. Licences can cover as few or as many users as you wish. With updates supplied as soon as they're available, you can be sure your documentation is current. For further information, email [bsmusales@bsigroup.com](mailto:bsmusales@bsigroup.com).

## BSI Group Headquarters

389 Chiswick High Road London W4 4AL UK

## Revisions

Our British Standards and other publications are updated by amendment or revision.

We continually improve the quality of our products and services to benefit your business. If you find an inaccuracy or ambiguity within a British Standard or other BSI publication please inform the Knowledge Centre.

## Copyright

All the data, software and documentation set out in all British Standards and other BSI publications are the property of and copyrighted by BSI, or some person or entity that owns copyright in the information used (such as the international standardization bodies) and has formally licensed such information to BSI for commercial publication and use. Except as permitted under the Copyright, Designs and Patents Act 1988 no extract may be reproduced, stored in a retrieval system or transmitted in any form or by any means – electronic, photocopying, recording or otherwise – without prior written permission from BSI. Details and advice can be obtained from the Copyright & Licensing Department.

## Useful Contacts:

### Customer Services

**Tel:** +44 845 086 9001

**Email (orders):** [orders@bsigroup.com](mailto:orders@bsigroup.com)

**Email (enquiries):** [cservices@bsigroup.com](mailto:cservices@bsigroup.com)

### Subscriptions

**Tel:** +44 845 086 9001

**Email:** [subscriptions@bsigroup.com](mailto:subscriptions@bsigroup.com)

### Knowledge Centre

**Tel:** +44 20 8996 7004

**Email:** [knowledgecentre@bsigroup.com](mailto:knowledgecentre@bsigroup.com)

### Copyright & Licensing

**Tel:** +44 20 8996 7070

**Email:** [copyright@bsigroup.com](mailto:copyright@bsigroup.com)



...making excellence a habit.™