

BS EN ISO 17380:2013



BSI Standards Publication

**Soil quality — Determination
of total cyanide and easily
liberatable cyanide —
Continuous-flow analysis
method (ISO 17380:2013)**

bsi.

...making excellence a habit.™

National foreword

This British Standard is the UK implementation of EN ISO 17380:2013. It supersedes BS ISO 17380:2004 which is withdrawn.

The UK participation in its preparation was entrusted to Technical Committee EH/4, Soil quality.

A list of organizations represented on this committee can be obtained on request to its secretary.

This publication does not purport to include all the necessary provisions of a contract. Users are responsible for its correct application.

© The British Standards Institution 2013. Published by BSI Standards Limited 2013

ISBN 978 0 580 76239 0

ICS 13.080.10

Compliance with a British Standard cannot confer immunity from legal obligations.

This British Standard was published under the authority of the Standards Policy and Strategy Committee on 31 July 2013.

Amendments issued since publication

Date	Text affected
------	---------------

EUROPEAN STANDARD

EN ISO 17380

NORME EUROPÉENNE

EUROPÄISCHE NORM

June 2013

ICS 13.080.10

English Version

Soil quality - Determination of total cyanide and easily liberatable cyanide - Continuous-flow analysis method (ISO 17380:2013)

Qualité du sol - Détermination des cyanures totaux et des cyanures aisément libérables - Méthode d'analyse en flux continu (ISO 17380:2013)

Bodenbeschaffenheit - Bestimmung des Gehalts an gesamtem Cyanid und leicht freisetzbarem Cyanid - Verfahren mittels kontinuierlicher Durchflußanalyse (ISO 17380:2013)

This European Standard was approved by CEN on 8 June 2013.

CEN members are bound to comply with the CEN/CENELEC Internal Regulations which stipulate the conditions for giving this European Standard the status of a national standard without any alteration. Up-to-date lists and bibliographical references concerning such national standards may be obtained on application to the CEN-CENELEC Management Centre or to any CEN member.

This European Standard exists in three official versions (English, French, German). A version in any other language made by translation under the responsibility of a CEN member into its own language and notified to the CEN-CENELEC Management Centre has the same status as the official versions.

CEN members are the national standards bodies of Austria, Belgium, Bulgaria, Croatia, Cyprus, Czech Republic, Denmark, Estonia, Finland, Former Yugoslav Republic of Macedonia, France, Germany, Greece, Hungary, Iceland, Ireland, Italy, Latvia, Lithuania, Luxembourg, Malta, Netherlands, Norway, Poland, Portugal, Romania, Slovakia, Slovenia, Spain, Sweden, Switzerland, Turkey and United Kingdom.



EUROPEAN COMMITTEE FOR STANDARDIZATION
COMITÉ EUROPÉEN DE NORMALISATION
EUROPÄISCHES KOMITEE FÜR NORMUNG

Management Centre: Avenue Marnix 17, B-1000 Brussels

Foreword

This document (EN ISO 17380:2013) has been prepared by Technical Committee ISO/TC 190 "Soil quality" in collaboration with Technical Committee CEN/TC 345 "Characterization of soils" the secretariat of which is held by NEN.

This European Standard shall be given the status of a national standard, either by publication of an identical text or by endorsement, at the latest by December 2013, and conflicting national standards shall be withdrawn at the latest by December 2013.

Attention is drawn to the possibility that some of the elements of this document may be the subject of patent rights. CEN [and/or CENELEC] shall not be held responsible for identifying any or all such patent rights.

According to the CEN-CENELEC Internal Regulations, the national standards organizations of the following countries are bound to implement this European Standard: Austria, Belgium, Bulgaria, Croatia, Cyprus, Czech Republic, Denmark, Estonia, Finland, Former Yugoslav Republic of Macedonia, France, Germany, Greece, Hungary, Iceland, Ireland, Italy, Latvia, Lithuania, Luxembourg, Malta, Netherlands, Norway, Poland, Portugal, Romania, Slovakia, Slovenia, Spain, Sweden, Switzerland, Turkey and the United Kingdom.

Endorsement notice

The text of ISO 17380:2013 has been approved by CEN as EN ISO 17380:2013 without any modification.

Contents

Page

Foreword	iv
Introduction	v
1 Scope	1
2 Normative references	1
3 Terms and definitions	1
4 Principle	2
4.1 Pretreatment of soil samples.....	2
4.2 Determination of total cyanide content.....	2
4.3 Determination of easily-liberatable cyanide content.....	2
5 Reagents	2
5.1 General reagents.....	2
5.2 Reagents for determination of cyanide.....	3
5.3 Standard solutions for cyanide determination.....	4
6 Apparatus	6
6.1 Standard laboratory glassware and laboratory equipment.....	6
6.2 Continuous flow analysis system.....	6
6.3 Shaking machine.....	7
7 Sampling, sample preparation and extraction	8
8 Working range	8
9 Procedure	8
9.1 General.....	8
9.2 Checking analysis system for correct function.....	8
9.3 Calibration graph.....	9
9.4 Measurement of samples.....	9
9.5 Cleaning of the analysis system.....	10
10 Calculation of the cyanide content in the sample	10
11 Precision	10
12 Test report	11
Annex A (informative) Recovery and repeatability	12
Annex B (informative) Information on continuous flow automatic distillation apparatus	14
Annex C (informative) Alternative distillation buffer (pH = 3,8)	15
Bibliography	16

Foreword

ISO (the International Organization for Standardization) is a worldwide federation of national standards bodies (ISO member bodies). The work of preparing International Standards is normally carried out through ISO technical committees. Each member body interested in a subject for which a technical committee has been established has the right to be represented on that committee. International organizations, governmental and non-governmental, in liaison with ISO, also take part in the work. ISO collaborates closely with the International Electrotechnical Commission (IEC) on all matters of electrotechnical standardization.

International Standards are drafted in accordance with the rules given in the ISO/IEC Directives, Part 2.

The main task of technical committees is to prepare International Standards. Draft International Standards adopted by the technical committees are circulated to the member bodies for voting. Publication as an International Standard requires approval by at least 75 % of the member bodies casting a vote.

Attention is drawn to the possibility that some of the elements of this document may be the subject of patent rights. ISO shall not be held responsible for identifying any or all such patent rights.

ISO 17380 was prepared by Technical Committee ISO/TC 190, *Soil quality*, Subcommittee SC 3, *Chemical methods and soil characteristics*.

This second edition cancels and replaces the first edition (ISO 17380:2004), which has been technically revised.

Introduction

Cyanides may be present in soil as cyanide ions and as complex cyanides. They can be determined as easily-liberatable cyanide or as total cyanide. Complex cyanide can be calculated by subtracting the easily-liberatable cyanide result from the total cyanide result. This International Standard specifies the determination of easily-liberatable cyanide, complex cyanides and total cyanide.

Methods using flow analysis automate wet chemical procedures and are particularly suitable for the processing of many analytes in water or soil extracts in large sample series at a high analysis frequency. The continuous flow analysis (CFA) method uses an automated dosage of the sample into a flow system (manifold) where the analytes in the sample react with the reagent solution on their way through the manifold. The sample preparation may be integrated in the manifold. The reaction product is measured in a photometric detector (e.g. flow cell photometer).^{[1],[2]}

In ISO 11262 a manual method for the photometric and volumetric determination of total cyanide in soil samples is described. It should be noted that the total cyanide results in soil samples as described in ISO 11262 may show slight differences from this International Standard. These differences are not considered to be very significant for this analysis. The easily-liberatable cyanide test has been removed from ISO 11262 because the validation data for this method were very poor.

For the analysis of cyanide in water ISO 14403-1^[6] and ISO 14403-2^[7] can be applied. The analytical procedure described in ISO 14403-2^[7] is identical to the one specified in this International Standard.

Soil quality — Determination of total cyanide and easily liberatable cyanide — Continuous-flow analysis method

WARNING — Cyanide solutions are highly toxic. Appropriate measures shall be taken to avoid ingestion. Care should be taken in the disposal of these solutions.

1 Scope

This International Standard specifies a method for the photometric determination of the total cyanide and easily-liberatable cyanide content in soil using automated distillation/continuous-flow analysis.

The International Standard applies to all types of soil with cyanide contents above 1 mg/kg on the basis of dry matter, expressed as cyanide ion.

NOTE Sulfide concentrations in the sample higher than 40 mg/kg dry matter cause interference. This effect can be recognized by the split peaks and as a slow decrease of the detector signal and can only be prevented by diluting the sample extract.

2 Normative references

The following documents, in whole or in part, are normatively referenced in this document and are indispensable for its application. For dated references, only the edition cited applies. For undated references, the latest edition of the referenced document (including any amendments) applies.

ISO 3696, *Water for analytical laboratory use — Specification and test methods*

ISO 9297, *Water quality — Determination of chloride — Silver nitrate titration with chromate indicator (Mohr's method)*

ISO 11262, *Soil quality — Determination of total cyanide*

ISO 11465, *Soil quality — Determination of dry matter and water content on a mass basis — Gravimetric method*

ISO 14507:2003, *Soil quality — Pretreatment of samples for determination of organic contaminants*

3 Terms and definitions

For the purposes of this document, the following terms and definitions apply.

3.1

total cyanide content

content of inorganic cyanide compounds consisting of the sum of the contents of easily-liberatable cyanide species and cyanide bound to metal cyanides, with the exception of thiocyanate ions and only partial breakdown of the cyanide bound in cobalt, gold, palladium and platinum cyanide complexes

3.2

easily-liberatable cyanide

content of inorganic cyanide compounds consisting of the sum of the contents of the easily-liberatable cyanide ions and the cyanide bound in simple metal cyanides (all expressed as CN) which are determined under the conditions of the method described in this International Standard

Note 1 to entry: The weakly complexed cyanide contained in tetracyanonickelate(II) and dicyanomercurate(II) is determined with the method for easily-liberatable cyanide. Up to 5 % of the strongly complexed cyanide in iron(III) hexacyanoferrate(II), hexacyanoferrate(III) and hexocyanoferrate(II) is determined with the method for easily-liberatable cyanide. Organic cyanide compounds (such as acetonitrile) are not determined.

Note 2 to entry: In connection with waste from the production of gold, “easily liberatable cyanide” is named “weak acid dissociable cyanide”^[8].

3.3 complex cyanide content

total cyanide content less than the easily-liberatable cyanide content

4 Principle

4.1 Pretreatment of soil samples

The soil sample is extracted with 2,5 mol/l sodium hydroxide solution for 16 h. The extract is diluted 100 times, after which analysis of total and/or easily-liberatable cyanide is performed.

4.2 Determination of total cyanide content

Complex bound cyanide, present in the diluted extract (0,025 mol/l NaOH), is decomposed in a continuously flowing stream after addition of a buffer solution, with an initial pH of 3,8, by the effect of UV light. An UV-B lamp and decomposition coil of borosilicate glass are used. UV light with a wavelength of less than 290 nm is absorbed by the glass, preventing the photolytic conversion of thiocyanate into cyanide. The hydrogen cyanide present at these conditions is separated by in-line distillation at a heating bath temperature of $125\text{ °C} \pm 2\text{ °C}$ and then determined photometrically. The photometric determination is based on the reaction of cyanide with chloramine-T resulting in the formation of cyanogen chloride. This reacts with pyridine-4-carboxylic acid and 1,3-dimethylbarbituric acid to give a purple colour. The absorbance at 606 nm is then measured to determine the cyanide content. When an interference filter is used, a peak wavelength of $600\text{ nm} \pm 10\text{ nm}$ can be used.

NOTE Addition of the buffer solution, with an initial pH of 3,8 (5.2.1), to the sample flow containing 0,025 mol/l NaOH (ratio 1,0 sample : 0,42 buffer) leads to a final pH of 4,0. Varying the pH of the distillation between 3,8 and 5,7 leads to very small fluctuations in the recovery of hydrogen cyanide (only a few percent).

4.3 Determination of easily-liberatable cyanide content

Before distillation, and without UV decomposition, a zinc sulfate solution is added to the sample flow, such that any complex iron cyanide(s) present are precipitated as zinc-cyanoferrate complexes. The hydrogen cyanide present during these conditions is separated by distillation at a temperature of 125 °C and photometrically determined as described under 4.2.

NOTE The added zinc sulfate replaces a water reagent (see Table 1) used in the determination of total cyanide content.

5 Reagents

Only use reagents of recognized analytical grade and demineralized water or distilled water according to ISO 3696, Grade 1 or 2.

5.1 General reagents

5.1.1 Hydrochloric acid $w(\text{HCl}) = 37\%$.

5.1.2 Hydrochloric acid $c(\text{HCl}) = 1\text{ mol/l}$.

Dilute 83 ml of hydrochloric acid (5.1.1) with water to 1 000 ml.

5.1.3 Hydrochloric acid $c(\text{HCl}) = 0,1\text{ mol/l}$.

Dilute 100 ml of 1 mol/l hydrochloric acid (5.1.2) with water to 1 000 ml.

5.1.4 Sodium hydroxide solution $c(\text{NaOH}) = 2,5 \text{ mol/l}$.

Dissolve 100 g of NaOH in water and dilute with water to 1 000 ml. Store in a polyethylene bottle.

5.1.5 Sodium hydroxide solution $c(\text{NaOH}) = 1 \text{ mol/l}$.

Dissolve 40 g of NaOH in water and dilute with water to 1 000 ml. Store in a polyethylene bottle.

5.1.6 Sodium hydroxide solution $c(\text{NaOH}) = 0,025 \text{ mol/l}$.

Dilute 25 ml of 1 mol/l sodium hydroxide ([5.1.5](#)) with water to 1 000 ml.

5.1.7 Detergent solution, polyoxyethylenelaurylether $\text{C}_{12}\text{H}_{25}(\text{OCH}_2\text{CH}_2)_n\text{OH}$, $n \approx 23$.

Dissolve 30 g of polyoxyethylenelaurylether by adding small quantities to 100 ml water and mix thoroughly.

NOTE This solution is commercially available as Brij-35. This information is given for the convenience of users of this document and does not constitute an endorsement by ISO of this product. To dissolve the Brij-35, the temperature can be raised to 40 °C.

5.1.8 Indicator solution

Dissolve 0,02 g of p-dimethylaminobenzylindenerhodanine in 100 ml acetone. This solution can be stored for at least one week if kept in the dark and refrigerated (5 ± 3) °C.

5.1.9 Silver nitrate solution, $c(\text{AgNO}_3) = 0,01 \text{ mol/l}$

Dissolve 1,689 7 g of silver nitrate in approximately 400 ml water and dilute to 1 litre in a volumetric flask with water. Check the actual concentration of the 0,01 mol/l silver nitrate by titration with sodium chloride according to ISO 9297 on a two weekly basis. Store this solution in the dark in a brown glass bottle. Prepare a fresh solution monthly.

5.1.10 Silver nitrate solution, $c(\text{AgNO}_3) = 0,001 \text{ mol/l}$

Prepare daily from 0,01 mol/l silver nitrate ([5.1.9](#)). Add 25,00 ml of 0,01 mol/l silver nitrate to a 250 ml volumetric flask and dilute to 250 ml with water. Store this solution in the dark in a brown glass bottle.

5.1.11 20 % V/V Denatured ethanol

Mix 100 ml denatured ethanol with 400 ml water. This solution is stable for at least one year.

5.2 Reagents for determination of cyanide

5.2.1 Distillation buffer (pH = 3,8)

Dissolve 50 g of citric acid, $\text{C}_6\text{H}_8\text{O}_7 \cdot \text{H}_2\text{O}$ in 200 ml water. Add 120 ml sodium hydroxide solution 1 mol/l ([5.1.5](#)) and if necessary adjust the pH to 3,8 with sodium hydroxide solution 1 mol/l ([5.1.5](#)), and dilute to 500 ml with water. This solution is stable for three months if it is kept in the dark and refrigerated (5 ± 3) °C.

NOTE See [Annex C](#) for details of an alternative modified buffer to overcome flow stability problems observed with some continuous flow systems caused by the high concentration of citric acid in this reagent.

5.2.2 Zinc sulfate solution

Dissolve 10 g of zinc sulfate heptahydrate, $\text{ZnSO}_4 \cdot 7 \text{H}_2\text{O}$, in 750 ml water, mix and dilute to 1 000 ml with water. This solution is stable at least 1 year.

5.2.3 Buffer solution for photometric determination (pH = 5,2)

Dissolve 2,3 g of sodium hydroxide in 500 ml water. Add 20,5 g of potassium hydrogen phthalate ($\text{KHC}_8\text{H}_4\text{O}_4$) and dilute to 975 ml with water. Adjust the pH of the solution to 5,2 with hydrochloric acid 1 mol/l (5.1.2) or sodium hydroxide solution 1 mol/l (5.1.5), add 1 ml detergent solution (5.1.7) and dilute to 1 000 ml with water. This solution is stable for three months if it is kept in the dark and refrigerated (5 ± 3) °C.

5.2.4 Chloramine-T solution

Dissolve 2,0 g of chloramine-T, $\text{C}_7\text{H}_7\text{ClNNaO}_2\text{S} \cdot 3 \text{H}_2\text{O}$ in 1 000 ml water. This solution is stable for one month if it is kept in the dark and refrigerated (5 ± 3) °C.

5.2.5 Colour reagent (pH = 5,2)

Dissolve 7,0 g of solid sodium hydroxide NaOH in 500 ml water. Add 16,8 g of 1,3-dimethylbarbituric acid, $\text{C}_6\text{H}_8\text{N}_2\text{O}_3$, and 13,6 g of pyridine-4-carboxylic acid, $\text{C}_6\text{H}_5\text{NO}_2$, and dilute to 975 ml with water. If necessary, adjust the pH of the solution to 5,2 with hydrochloric acid 1 mol/l (5.1.2) or sodium hydroxide solution 1 mol/l (5.1.5) and then dilute to 1 000 ml with water.

Stir vigorously for 1 h at 30 °C and then filter over a pleated filter. This solution is stable for three months provided it is stored in the dark and refrigerated (5 ± 3) °C, and filtered over a pleated filter before use.

5.2.6 Rinse solution for the sampler (0,025 mol/l sodium hydroxide)

Add 25 ml sodium hydroxide solution 1 mol/l (5.1.5) and dilute to 1 000 ml with water. This solution is stable for three months.

5.3 Standard solutions for cyanide determination

5.3.1 Stability

The concentrated standard solutions (5.3.2.1, 5.3.3.1 and 5.3.3.3) are stable for at least three months and the diluted standard solutions for at least one week provided they are stored in the dark and refrigerated (5 ± 3) °C.

5.3.2 Potassium cyanide standard solutions

5.3.2.1 Cyanide standard solution corresponding to 100 mg/l of cyanide ion

Dissolve 0,250 g of potassium cyanide KCN in sodium hydroxide solution 0,025 mol/l (5.1.6) and in a volumetric flask of 1 000 ml make up with sodium hydroxide solution 0,025 mol/l (5.1.6).

Transfer, by means of a pipette, into a beaker, 10 ml high standard cyanide solution with a content of 100 mg/l CN (5.3.2.1). Add 0,25 ml indicator solution (5.1.8). Perform a titration with the silver nitrate solution (5.1.10) until the colour changes from yellow to yellow-red (titration volume V_1).

Calculate the cyanide content in the standard cyanide solution with Formula (1):

$$\rho_{\text{CN}} = V_1 \cdot c_{(\text{AgNO}_3)} \cdot M_{(2\text{CN})} / V \quad (1)$$

where

ρ_{CN} is the cyanide content in the standard cyanide solution in milligrams per litre;

V_1 is the quantity of silver nitrate solution (5.1.9) used in millilitres;

$c_{(\text{AgNO}_3)}$ is the concentration of silver nitrate in millimoles per litre;

$M_{(2\text{CN})}$ is the molar mass of 2 CN (= 52 g/mol);

V is the volume of the standard cyanide solution in millilitres (in this case = 10 ml).

NOTE Commercially available standard solutions may also be used (e.g. potassium tetracyanozincate, $\text{K}_2\text{Zn}(\text{CN})_4$, $c(\text{CN} = 1\,000 \pm 2 \text{ mg/l})$).

5.3.2.2 Cyanide standard solution corresponding to 1 mg/l of cyanide ion

Transfer, by means of a pipette, 2,5 ml of the 100 mg/l cyanide solution (5.3.2.1) in a volumetric flask of 250 ml and fill to the mark with sodium hydroxide solution 0,025 mol/l (5.1.6).

5.3.3 Control solutions

5.3.3.1 Potassium thiocyanate solution corresponding to 100 mg/l of cyanide ion

Dissolve 0,373 g of potassium thiocyanate, KSCN (dried at 105 °C, stored in a desiccator), in sodium hydroxide solution 0,025 mol/l (5.1.6) and in a 1000 ml volumetric flask make up with sodium hydroxide solution 0,025 mol/l (5.1.6).

5.3.3.2 Potassium thiocyanate solution corresponding to 1 mg/l of cyanide ion

Transfer, by means of a pipette, 2,5 ml of the 100 mg/l standard thiocyanate solution (5.3.3.1) (equivalent to 100 mg/l CN^-) into a 250 ml volumetric flask and fill to the mark with sodium hydroxide solution 0,025 mol/l (5.1.6).

5.3.3.3 Potassium hexacyanoferrate solution corresponding to 100 mg/l of cyanide ion

Dissolve 0,211 g of potassium hexacyanoferrate, $\text{K}_3[\text{Fe}(\text{III})(\text{CN})_6]$ (dried at 105 °C, stored in a desiccator), in sodium hydroxide solution 0,025 mol/l (5.1.6) and in a volumetric flask of 1 000 ml make up with sodium hydroxide solution 0,025 mol/l (5.1.6).

5.3.3.4 Potassium hexacyanoferrate solution corresponding to 1 mg/l of cyanide ion

Transfer, by means of a pipette, 2,5 ml potassium hexacyanoferrate solution (5.3.3.3) (equivalent to 100 mg/l CN^-) into a 250 ml volumetric flask and fill to the mark with sodium hydroxide solution 0,025 mol/l (5.1.6).

5.3.3.5 Potassium hexacyanoferrate solution corresponding to 0,1 mg/l of cyanide ion

Transfer, by means of a pipette, 10 ml of 1 mg/l potassium hexacyanoferrate[III] solution (5.3.3.4) into a 100 ml volumetric flask and make up to the mark with sodium hydroxide solution 0,025 mol/l (5.1.6).

NOTE Solutions 5.3.3.2 and 5.3.3.5 are used to check the correct operation of the total cyanide method (see 9.2.4 and 9.2.5). Solutions 5.3.3.2 and 5.3.3.4 are used to check the correct operation of the easily-liberatable cyanide method (see 9.2.6 to 9.2.7).

6 Apparatus

6.1 Standard laboratory glassware and laboratory equipment

Use brown or green coloured laboratory glassware to prevent the breakdown of complex cyanides or thiocyanate by daylight.

6.2 Continuous flow analysis system

A typical continuous flow analysis system is shown in [Figure 1](#). This type of continuous flow automatic distillation apparatus is available commercially from a number of manufacturers (see [Annex B](#)).

NOTE The same system as mentioned in ISO 14403-2 can be used. Continuous flow system cyanide manifold design varies slightly from manufacturer to manufacturer. The key issue is ensuring suitable validation data are obtained by the user before employing the method for routine analysis.

The specification given below is an example of a “fit for purpose system”. For every individual apparatus optimal conditions have to be established and validated.

A sample changer is used to set appropriate sample and rinsing times (for example 80 and 160 s resp.).

For the UV decomposition (see 3 in [Figure 1](#)), a UV-B lamp with an emission maximum of (312 ± 5) nm of at least 8 W power shall be used. The decomposition coil shall be made from borosilicate glass with a capacity of approximately 13 ml and approximately 45 turns with a coil diameter of 30 mm; the tube shall have a wall thickness of max. 1 mm and an internal diameter of max. 2 mm. Borosilicate glass type DURAN 8330¹⁾ is recommended. The equipment shall be designed such that no UV light with a wavelength of less than 290 nm can reach the flow of fluid.

The distillation coil (see 5 in [Figure 1](#)) with at least 40 turns shall be placed vertically. The distillation heater temperature shall be adjusted to 125 °C with an accuracy of 1 °C. The distillation equipment shall be designed in such way that, on determination of total cyanide, less than 10 µg/l CN is found while measuring a thiocyanate solution with a concentration of 1 000 µg/l as CN. The reaction coils (coolers) (see 6 and 7 in [Figure 1](#)) after the distillation equipment can be connected in line. The heating bath (see 8 in [Figure 1](#)) shall be set to 37 °C ± 2 °C and the reaction coil shall be designed such that a retention period of approximately 4 min is achieved.

The photometer (see 9 in [Figure 1](#)) shall be equipped with a continuous flow cell with optical path length of 50 mm and a filter of 600 nm ± 10 nm with a band width of max. 10 nm. The maximum absorption occurs at 606 nm and this wavelength should be used if a spectrometer is employed.

1) DURAN 8330 is an example of a suitable product available commercially. This information is given for the convenience of users of this document and does not constitute an endorsement by ISO of this product.

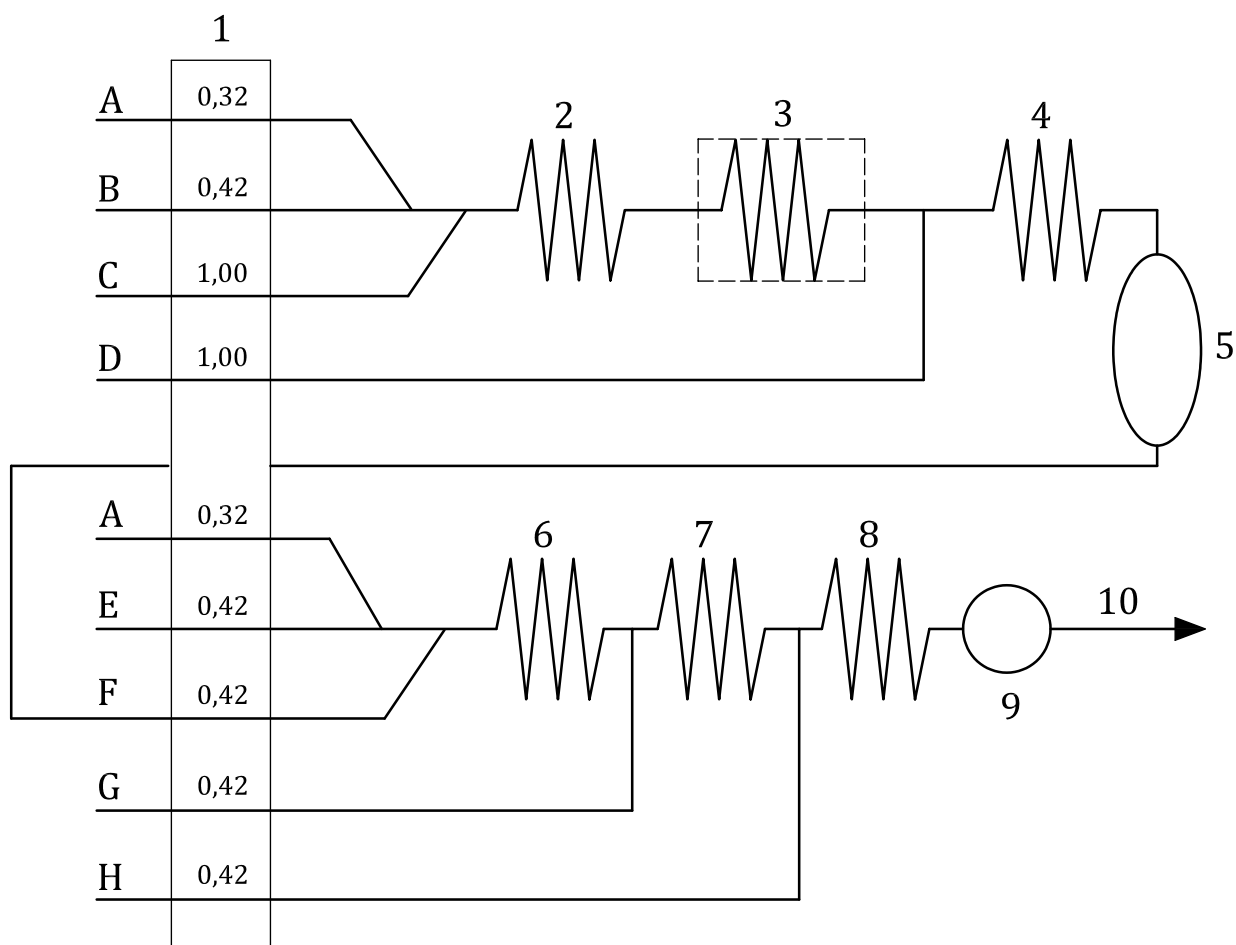

Key

- | | | | |
|---|---|----|--|
| A | Segmentation gas (air) | 1 | Pump (flow rates in ml/min) |
| B | Buffer for distillation (5.2.1) | 2 | Reaction coil (50 cm, Ø int. 1,5 mm) |
| C | Sample | 3 | UV-B lamp (decomposition coil) (312 nm ± 5 nm) |
| D | ZnSO ₄ solution (5.2.2) for easily-liberatable cyanide, or water for total cyanide (see Table 1) | 4 | Reaction coil (50 cm, Ø int. 1,5 mm) |
| E | Buffer solution for final photometric determination (5.2.3) | 5 | Distillation coil (125 °C ± 1 °C) |
| F | Resample | 6 | Reaction coil (50 cm, Ø int. 1,5 mm) |
| G | Chloramine-T trihydrate solution (5.2.4) | 7 | Reaction coil (50 cm, Ø int. 1,5 mm) |
| H | Colour reagent (5.2.5) | 8 | Heating bath (37 °C ± 2 °C, 100 cm, Ø int. 2 mm) |
| | | 9 | Photometer (e.g. 50 mm optical path length), wavelength 590 nm to 610 nm |
| | | 10 | Waste |

Figure 1 — Typical continuous flow system for the photometric determination of easily-liberatable and total cyanide (10 µg/l to 100 µg/l) with a distillation procedure

6.3 Shaking machine

Shaking machine with a shaking motion which allows an optimal contact between the sample and the extraction liquid.

NOTE Good results are obtained with an apparatus with a horizontal movement (motion) of 180 strokes per minute and a stroke length of 5 cm with the 500 ml polyethylene extraction vessels in horizontal position.

7 Sampling, sample preparation and extraction

Take a field moist representative soil sample, stored for up to four days in a refrigerator at $(5 \pm 3) ^\circ\text{C}$; (see NOTE 1). Remove visible coarse constituents, as cyanide is labile the test portion should be prepared according to ISO 14507. Follow the procedure for volatile compounds, given in 8.2 of ISO 14507:2003. Suspend a quantity of the sample equivalent to approximately 40 g of dry matter, accurate to 0,1 g in 200 ml sodium hydroxide solution 2,5 mol/l (5.1.4) in a 500 ml polyethylene bottle. Shake for 16 h using the apparatus specified in 6.3. During this period, prevent irradiation by light, to minimize the decomposition of complex cyanides. Afterwards filter the suspension using a fit to purpose analytical filter paper. Dilute the extract by a factor of 100 (f_1) water. Any other dilutions should be made with 0,025 mol/l sodium hydroxide solution (5.1.6). Analyse the diluted extract using the method for total and/or easily-liberatable cyanide as soon as possible but within 4 days. Care must be exercised when handling sodium hydroxide solutions (see NOTE 2).

NOTE 1 A stability study has demonstrated that refrigerated soil samples are stable for at least four days.^[4]

NOTE 2 2,5 mol/l sodium hydroxide is extremely corrosive to human tissue. It is essential that adequate eye protection is worn when handling sodium hydroxide solutions.

NOTE 3 Extraction by shaking for 1 h with 1 mol/l sodium hydroxide solution has been found to be adequate for many samples. Before using this modification, the user should validate this extraction with a wide range of typical samples.

8 Working range

The continuous flow analysis system shown in Figure 1 has a working range from 2 $\mu\text{g/l}$ to 100 $\mu\text{g/l}$ cyanide (expressed as CN). For a sample aliquot equivalent to 40 g of dry matter, this corresponds to 1 mg/kg to 50 mg/kg cyanide after the 100 fold dilution of the sodium hydroxide extract.

9 Procedure

9.1 General

Before performing the continuous flow analysis, consult the equipment operating instructions.

9.2 Checking analysis system for correct function

9.2.1 Adjust the continuous flow analysis system according to Table 1 depending on the determination to be performed.

Table 1 — Adjustment of continuous flow analysing system

Continuous flow analysis part/ medium	Part/parameter to be used	Setting for determination of	
		Total cyanide	Easily-liberatable cyanide
UV decomposition	Borosilicate glass coil UV-B lamp	On	Off
Solution	After UV lamp	Water	Zinc sulfate solution (5.2.2)
Distillation	Temperature	125 $^\circ\text{C}$	125 $^\circ\text{C}$
	Distillation buffer pH (5.2.1)	3,8	3,8
Photometric final determination	Colour reagent pH (5.2.5)	5,2	5,2
	Wavelength	600 nm \pm 10 nm	600 nm \pm 10 nm

9.2.2 Set the analysing system into operation at first by pumping water and afterwards the reagents (5.2) into the system. Set the baseline of the automatic recorder, after it has stabilized, to 10 scale divisions. Measure in succession two standard cyanide solutions with a concentration of 100 µg/l (see 9.3) in order to set the full-scale deflection to 90 scale divisions, followed by two blanks to monitor the baseline.

9.2.3 Check that the system is working correctly before proceeding according to the instructions of the manufacturer.

9.2.4 Prior analysis checks should also be made to confirm that less than 5 % of the bound cyanide in hexacyanoferrate[III] is detected as easily-liberatable cyanide and that over 95 % of the bound cyanide in hexacyanoferrate[III] is detected as total cyanide. Also there should be negligible breakdown of thiocyanate ion to cyanide (see 9.2.5, 9.2.6 and 9.2.7). Calculate the recovery using Formula (2):

$$R_{(\text{CN})} \text{ test solution} = (\text{measured value test solution} / \text{measured value } 100 \text{ } \mu\text{g/l cyanide solution}) \times 100 \quad (2)$$

9.2.5 The system is suitable for the measurement of total cyanide if the recovery of the 100 µg/l standard solution of hexacyanoferrate[III] (5.3.3.5) expressed as cyanide is at least 90 %. A recovery of hexacyanoferrate[III] less than 90 % indicates inadequate effectiveness of the UV decomposition (i.e. $R_{(\text{CN})}$ hexacyanoferrate < 90 %). In this case clean the system (9.5) and, if necessary, replace the lamp.

9.2.6 For the determination of easily-liberatable cyanide, the system is suitable if the recovery of the 1 mg/l standard solution of hexacyanoferrate[III] (5.3.3.4) is less than 5 % (i.e. $R_{(\text{CN})}$ hexacyanoferrate < 5 %). If higher levels of easily-liberatable cyanide than this are measured, significant breakdown of the hexacyanoferrate to cyanide has occurred. Prepare a fresh hexacyanoferrate solution, check the lamp and the reaction coil material meet the specification (see 6.2).

9.2.7 Prior to analysis checks should be made confirm negligible breakdown of thiocyanate occurs when determining easily-liberatable and total cyanide. For total or easily-liberatable cyanide no more than 10 µg/l cyanide of either species shall be found on measurement of a thiocyanate solution of $c(\text{as CN}) = 1\,000 \text{ } \mu\text{g/l}$ (5.3.3.2) (i.e. $R_{(\text{CN})}$ thiocyanate < 1 %). If higher levels of easily-liberatable cyanide than this are measured, significant breakdown of the thiocyanate to cyanide has occurred. Prepare a fresh thiocyanate solution, check the lamp and the reaction coil material meet the specification (see 6.2).

9.3 Calibration graph

Prepare a series of calibration standards by transferring by means of a pipette 0,5 ml; 1 ml; 2 ml; 4 ml; 5 ml; 6 ml; 8 ml and 10 ml of the 1 mg/l standard cyanide solution (5.3.2.2) respectively in a 100 ml volumetric flask and making up to the mark with 0,025 mol/l sodium hydroxide solution (5.1.6). These solutions contain 5 µg/l, 10 µg/l, 20 µg/l, 40 µg/l, 50 µg/l, 60 µg/l, 80 µg/l and 100 µg/l CN respectively (before the corrections for the concentration found on titration of the standard solution, see Clause 10). They should be prepared daily. Measure the entire calibration series. Plot a graph of the peak heights h_x of the calibration standards against the cyanide content c_x in µg/l. The calibration graph should be linear under these conditions.

NOTE The response of the system to sodium hydroxide concentration is effectively constant over the range 0,010 mol/l to 0,25 mol/l NaOH.

9.4 Measurement of samples

Dilute the diluted sample extract f_2 with 0,025 mol/l sodium hydroxide solution (5.1.6) until the cyanide concentration lies within the measurement range, but preferably no lower than 10 % of the highest concentration of the working range.

Place after every 20th sample a control solution, e.g. a cyanide calibration solution containing 50 µg CN per litre and then a blank solution in the sampler in order to correct for any change in sensitivity or baseline drift.

9.5 Cleaning of the analysis system

After the distillation bath has been shut down and cooled below 100 °C, the manifold is first rinsed by pumping water through the system. At suitable intervals, or at least every two months rinse the system with sodium hydroxide solution $c(\text{NaOH}) = 0,1 \text{ mol/l}$ for 30 min to remove any dirt.

If the system is contaminated with a residue of salts, rinse with hydrochloric acid (5.1.2) for 30 min followed by thoroughly rinsing with water. If the UV-decomposition spiral is contaminated (e.g. with detergent), rinse for 15 min with 1 mol/l hydrochloric acid (5.1.2). Disconnect the coil and rinse with 20 % v/v denatured ethanol (5.1.11), followed by water.

10 Calculation of the cyanide content in the sample

Give the analysis result as the number of mg total and/or easily-liberatable cyanide per kilogramme dry matter. Read for every peak the CN concentration from the calibration graph. Calculate the cyanide content in the soil sample expressed in milligrams per kg using Formula (3):

$$W_{(\text{CN})} = W_x \times f_1 \times f_2 \times \frac{V + \left(\frac{100 - W_{\text{dm}} \times m}{100} \right)}{1000 \times m} \times \frac{100}{W_{\text{dm}}} \quad (3)$$

where

$W_{(\text{CN})}$ is the cyanide content of the sample dried (105 °C), in milligrams per kilogram;

W_x is the cyanide content in the diluted extract determined from the calibration graph in micrograms per litre;

f_1 is the initial dilution factor (= 100) of the sample extract to the diluted extract (Clause 7);

f_2 is any further dilution factor of the diluted sample extract in order to get the cyanide concentration of the diluted extract within the measurement range (9.3); If no further dilution is used then $f_2 = 1$.

V is the volume of sodium hydroxide solution used for the extraction in millilitres (= 200 ml);

W_{dm} is the dry matter content of the soil expressed as a percentage (according to ISO 11465);

m is the original mass of the sample aliquot taken, in grams.

Report the results to two significant figures at most.

11 Precision

An inter-laboratory trial was organized to test the procedures specified in this International Standard. In this trial, the amount of easily-liberatable and total cyanides was determined by a number of laboratories on three soils.

The repeatability standard deviation (S_r), the reproducibility standard deviation (S_R), the relative repeatability standard deviation ($C_{V,r}$) and the relative reproducibility standard deviation ($C_{V,R}$) of the results of these analyses are given in Annex A.

12 Test report

The test report shall contain the following information:

- a) a reference to this International Standard;
- b) complete identification of the sample;
- c) the results of the determination in mg/kg on a dry matter basis;
- d) any details not specified in this International Standard or which are optional, as well as any factor which may have affected the results.

Annex A (informative)

Recovery and repeatability

In an intralaboratory trial the recovery and repeatability for standard solutions of the methods described in this International Standard, the following results were obtained.^[3]

See [Tables A.1, A.2](#) and [A.3](#).

Table A.1 — Results achieved for standard solutions

Standard solution	N Measurements	Cyanide con- tent µg/l	Total cyanide content		Easily-liberatable cyanide con- tent	
			Mean recovery %	Relative stand- ard deviation	Mean recovery %	Relative stand- ard deviation
KCN	40	50	98,8	1,9	98,9	1,9
Fe ₄ [Fe(CN) ₆] ₃	10	65,4	87,3	2,9	4,2	0,8
K ₃ Fe[III] (CN) ₆	25	50	98,3	0,9	4,6	0,6
K ₄ Fe[II] (CN) ₆	25	50	99,5	2,2	4,5	0,6
Ni[II] (CN) ₄	25	50	99,0	2,2	99,3	1,9

In an interlaboratory trial the following validation data were obtained using the method described in this International Standard. Data are calculated according to ISO 5725-2.^[5]

Table A.2 — Results achieved for determination of easily-liberatable cyanide in soil samples

Sample	Easily-liberatable cyanide								
	<i>N</i>	<i>N</i> Measure- ments	\bar{X} mg/kg	<i>S_r</i> mg/kg	<i>S_R</i> mg/kg	<i>C_{V,r}</i> %	<i>C_{V,R}</i> %	<i>r</i> mg/kg	<i>R</i> mg/kg
Soil I	12 (0)	24	1,70	0,150	0,609	8,8	35,8	0,42	1,65
Soil II	12 (0)	24	5,18	0,409	1,40	7,9	27,1	1,15	3,93
Soil III	12 (0)	24	16,3	1,19	3,91	7,3	24,0	3,36	11,0
Standard	11 (1)	22	24,1	0,530	1,13	2,2	4,7	1,45	3,18

N is the number of laboratories left over after rejection of statistical outliers according to ISO 5725-2;
 () is the number of rejected results;
 \bar{X} is the mean value, in milligrams per kilogram (mg/kg);
S_r is the repeatability standard deviation, in milligrams per kilogram (mg/kg);
C_{V,r} is the relative repeatability standard deviation, in per cent (%);
S_R is the reproducibility standard deviation, in milligrams per kilogram (mg/kg);
C_{V,R} is the relative reproducibility standard deviation, in per cent (%);
r is the repeatability, in milligrams per kilogram (mg/kg);
R is the reproducibility, in milligrams per kilogram (mg/kg).

Table A.3 — Results achieved for determination of total cyanide in soil samples

Sample	Total cyanide								
	<i>N</i>	<i>N</i> ^o Measure- ments	\bar{X} mg/kg	<i>S_r</i> mg/kg	<i>S_R</i> mg/kg	<i>C_{V,r}</i> %	<i>C_{V,R}</i> %	<i>r</i> mg/kg	<i>R</i> mg/kg
Soil I	14 (0)	28	7,73	0,356	1,03	4,6	13,3	0,99	2,89
Soil II	14 (0)	28	31,8	0,795	3,34	2,5	10,5	2,21	9,35
Soil III	13 (1)	26	193	5,98	20,8	3,1	10,8	16,8	58,2
Standard	12 (2)	24	63,8	1,21	6,12	1,9	9,6	3,18	1,72

N is the number of laboratories left over after rejection of statistical outliers according to ISO 5725-2;
 () is the number of rejected results;
 \bar{X} is the mean value, in milligrams per kilogram (mg/kg);
S_r is the repeatability standard deviation, in milligrams per kilogram (mg/kg);
C_{V,r} is the relative repeatability standard deviation, in per cent (%);
S_R is the reproducibility standard deviation, in milligrams per kilogram (mg/kg);
C_{V,R} is the relative reproducibility standard deviation, in per cent (%);
r is the repeatability, in milligrams per kilogram (mg/kg);
R is the reproducibility, in milligrams per kilogram (mg/kg).

Annex B (informative)

Information on continuous flow automatic distillation apparatus

Air-segmented continuous flow analysis consists of a number of single samples which are converted into a continuous flowing stream by a pumping system and the necessary reagent additions are made by continuous pumping and merging of the sample and reagent streams. The stream is continuously segmented by air. Ultimately a treated sample is pumped to a flow-through photometric measuring unit and then to waste.

For calculation, a suitable data system should be used

A processing rate of 20 samples to 60 samples per hour is usual and several samples are usually being processed at any one time between the sampling and measurement stages. However, there is usually no difficulty in associating each recorded detector response with a particular sample since the regular timing intervals between stages are controlled. The insertion of frequent standards in the sample sequence affords regular data points. Precautions are taken to prevent interaction that can occur in a continuous system thereby causing loss of discrimination between successive samples at the recording stage.

Continuous micro distillation for separation of volatile hydrogen cyanide is carried out using an electronically heated reactor or a suitable oil bath. The vapours are subsequently re-absorbed into a liquid stream and subsequently determined colorimetrically.

Some continuous flow systems are subject to flow instability with the (pH = 3,8) 10 % *m/V* citric acid buffer specified in [5.2.1. Annex C](#) gives details of an alternative (pH = 3,8) distillation buffer with a five times lower citric acid content, but containing some hydrochloric acid.

Annex C (informative)

Alternative distillation buffer (pH = 3,8)

5.2.1 Distillation buffer (pH = 3,8) with lower citric acid content to avoid flow instability problems.

Dissolve in about 350 ml water 10 g of citric acid. Add 50 ml of sodium hydroxide solution I ([5.1.4](#)) and, if necessary, adjust to pH 3,8 with hydrochloric acid ([5.1.2](#)) or sodium hydroxide solution II ([5.1.5](#)). Add 12,5 ml of hydrochloric acid ([5.1.2](#)). Dilute to 500 ml with water.

NOTE Due to the final HCl addition the pH of this buffer is about 3,4. After mixing with the sample a pH of 3,8 is achieved.

This solution is stable for three months if stored in a refrigerator (5 ± 3) °C.

Bibliography

- [1] KELADA N.P. Automated direct measurements of total cyanide species and thiocyanates, and their distribution in waste water and sludge. *J. Water Pollut. Control Fed.* 1989, **61** (3) pp. 350–356
- [2] MEEUSSEN J.C.L., TEMMINGHOFF E.J.M., KEIZER M.G., NOVOZAMSKY I. Spectrophotometric determination of total cyanide, iron-cyanide complexes and thiocyanate in water by a continuous flow system. *Analyst (Lond.)*. 1989, **114** (118) pp. 959–963
- [3] TAUW Infra Consult B.V. Laboratory study on cyanide determination, Project No. 3162052, Deventer, May 1992
- [4] Validation report NEN 6655, Determination of total and free cyanide, Deventer, May, 1995 (Tauw Infra Consult B.V. Project No. R3355527 LO1/MAO)
- [5] ISO 5725-2, *Accuracy (trueness and precision) of measurement methods and results — Part 2: Basic method for the determination of repeatability and reproducibility of a standard measurement method*
- [6] ISO 14403-1, *Water quality — Determination of total cyanide and free cyanide using flow analysis (FIA and CFA) — Part 1: Method using flow injection analysis (FIA)*
- [7] ISO 14403-2, *Water quality — Determination of total cyanide and free cyanide using flow analysis (FIA and CFA) — Part 2: Method using continuous flow analysis (CFA)*
- [8] Cyanide Management Code For the Manufacture, Transport, and Use of Cyanide in the Production of Gold; published: www.cyanidecode.org

British Standards Institution (BSI)

BSI is the national body responsible for preparing British Standards and other standards-related publications, information and services.

BSI is incorporated by Royal Charter. British Standards and other standardization products are published by BSI Standards Limited.

About us

We bring together business, industry, government, consumers, innovators and others to shape their combined experience and expertise into standards-based solutions.

The knowledge embodied in our standards has been carefully assembled in a dependable format and refined through our open consultation process. Organizations of all sizes and across all sectors choose standards to help them achieve their goals.

Information on standards

We can provide you with the knowledge that your organization needs to succeed. Find out more about British Standards by visiting our website at bsigroup.com/standards or contacting our Customer Services team or Knowledge Centre.

Buying standards

You can buy and download PDF versions of BSI publications, including British and adopted European and international standards, through our website at bsigroup.com/shop, where hard copies can also be purchased.

If you need international and foreign standards from other Standards Development Organizations, hard copies can be ordered from our Customer Services team.

Subscriptions

Our range of subscription services are designed to make using standards easier for you. For further information on our subscription products go to bsigroup.com/subscriptions.

With **British Standards Online (BSOL)** you'll have instant access to over 55,000 British and adopted European and international standards from your desktop. It's available 24/7 and is refreshed daily so you'll always be up to date.

You can keep in touch with standards developments and receive substantial discounts on the purchase price of standards, both in single copy and subscription format, by becoming a **BSI Subscribing Member**.

PLUS is an updating service exclusive to BSI Subscribing Members. You will automatically receive the latest hard copy of your standards when they're revised or replaced.

To find out more about becoming a BSI Subscribing Member and the benefits of membership, please visit bsigroup.com/shop.

With a **Multi-User Network Licence (MUNL)** you are able to host standards publications on your intranet. Licences can cover as few or as many users as you wish. With updates supplied as soon as they're available, you can be sure your documentation is current. For further information, email bsmusales@bsigroup.com.

BSI Group Headquarters

389 Chiswick High Road London W4 4AL UK

Revisions

Our British Standards and other publications are updated by amendment or revision.

We continually improve the quality of our products and services to benefit your business. If you find an inaccuracy or ambiguity within a British Standard or other BSI publication please inform the Knowledge Centre.

Copyright

All the data, software and documentation set out in all British Standards and other BSI publications are the property of and copyrighted by BSI, or some person or entity that owns copyright in the information used (such as the international standardization bodies) and has formally licensed such information to BSI for commercial publication and use. Except as permitted under the Copyright, Designs and Patents Act 1988 no extract may be reproduced, stored in a retrieval system or transmitted in any form or by any means – electronic, photocopying, recording or otherwise – without prior written permission from BSI. Details and advice can be obtained from the Copyright & Licensing Department.

Useful Contacts:

Customer Services

Tel: +44 845 086 9001

Email (orders): orders@bsigroup.com

Email (enquiries): cservices@bsigroup.com

Subscriptions

Tel: +44 845 086 9001

Email: subscriptions@bsigroup.com

Knowledge Centre

Tel: +44 20 8996 7004

Email: knowledgecentre@bsigroup.com

Copyright & Licensing

Tel: +44 20 8996 7070

Email: copyright@bsigroup.com



...making excellence a habit.™