

BS EN ISO 17231:2011



BSI Standards Publication

**Leather — Physical and
mechanical tests —
Determination of water
repellency of garment leather
(ISO 17231:2006)**

bsi.

...making excellence a habit.™

National foreword

This British Standard is the UK implementation of EN ISO 17231:2011. It is identical to ISO 17231:2006. It supersedes BS EN 14340:2004 which is withdrawn.

The UK participation in its preparation was entrusted to Technical Committee TCI/69, Footwear, leather and coated fabrics.

A list of organizations represented on this committee can be obtained on request to its secretary.

This publication does not purport to include all the necessary provisions of a contract. Users are responsible for its correct application.

© BSI 2011

ISBN 978 0 580 72292 9

ICS 59.140.30

Compliance with a British Standard cannot confer immunity from legal obligations.

This British Standard was published under the authority of the Standards Policy and Strategy Committee on 30 September 2011.

Amendments issued since publication

Date	Text affected
------	---------------

English Version

Leather - Physical and mechanical tests - Determination of water repellency of garment leather (ISO 17231:2006)

Cuir - Essais physiques et mécaniques - Détermination de la résistance au mouillage superficiel des cuirs pour vêtements (ISO 17231:2006)

Leder - Physikalische und mechanische Prüfungen - Bestimmung der wasserabweisenden Eigenschaften von Bekleidungsleder (ISO 17231:2006)

This European Standard was approved by CEN on 18 August 2011.

CEN members are bound to comply with the CEN/CENELEC Internal Regulations which stipulate the conditions for giving this European Standard the status of a national standard without any alteration. Up-to-date lists and bibliographical references concerning such national standards may be obtained on application to the CEN-CENELEC Management Centre or to any CEN member.

This European Standard exists in three official versions (English, French, German). A version in any other language made by translation under the responsibility of a CEN member into its own language and notified to the CEN-CENELEC Management Centre has the same status as the official versions.

CEN members are the national standards bodies of Austria, Belgium, Bulgaria, Croatia, Cyprus, Czech Republic, Denmark, Estonia, Finland, France, Germany, Greece, Hungary, Iceland, Ireland, Italy, Latvia, Lithuania, Luxembourg, Malta, Netherlands, Norway, Poland, Portugal, Romania, Slovakia, Slovenia, Spain, Sweden, Switzerland and United Kingdom.



EUROPEAN COMMITTEE FOR STANDARDIZATION
COMITÉ EUROPÉEN DE NORMALISATION
EUROPÄISCHES KOMITEE FÜR NORMUNG

Management Centre: Avenue Marnix 17, B-1000 Brussels

Foreword

The text of ISO 17231:2006 has been prepared by International Union of Leather Technologists and Chemists Societies and has been taken over as EN ISO 17231:2011 by Technical Committee CEN/TC 289 "Leather" the secretariat of which is held by UNI.

This European Standard shall be given the status of a national standard, either by publication of an identical text or by endorsement, at the latest by March 2012, and conflicting national standards shall be withdrawn at the latest by March 2012.

Attention is drawn to the possibility that some of the elements of this document may be the subject of patent rights. CEN [and/or CENELEC] shall not be held responsible for identifying any or all such patent rights.

This document supersedes EN 14340:2004.

According to the CEN/CENELEC Internal Regulations, the national standards organizations of the following countries are bound to implement this European Standard: Austria, Belgium, Bulgaria, Croatia, Cyprus, Czech Republic, Denmark, Estonia, Finland, France, Germany, Greece, Hungary, Iceland, Ireland, Italy, Latvia, Lithuania, Luxembourg, Malta, Netherlands, Norway, Poland, Portugal, Romania, Slovakia, Slovenia, Spain, Sweden, Switzerland and the United Kingdom.

Endorsement notice

The text of ISO 17231:2006 has been approved by CEN as a EN ISO 17231:2011 without any modification.

Foreword

ISO (the International Organization for Standardization) is a worldwide federation of national standards bodies (ISO member bodies). The work of preparing International Standards is normally carried out through ISO technical committees. Each member body interested in a subject for which a technical committee has been established has the right to be represented on that committee. International organizations, governmental and non-governmental, in liaison with ISO, also take part in the work. ISO collaborates closely with the International Electrotechnical Commission (IEC) on all matters of electrotechnical standardization.

International Standards are drafted in accordance with the rules given in the ISO/IEC Directives, Part 2.

The main task of technical committees is to prepare International Standards. Draft International Standards adopted by the technical committees are circulated to the member bodies for voting. Publication as an International Standard requires approval by at least 75 % of the member bodies casting a vote.

Attention is drawn to the possibility that some of the elements of this document may be the subject of patent rights. ISO shall not be held responsible for identifying any or all such patent rights.

ISO 17231 was prepared by the Physical Test Commission of the International Union of Leather Technologists and Chemists Societies (IUP Commission, IULTCS) in collaboration with the European Committee for Standardization (CEN) Technical Committee CEN/TC 289 *Leather*, the secretariat of which is held by UNI. It was published as EN 14340. It is based on IUP 37 published in *J. Soc. Leather Tech. Chem.*, **86** (7), p. 339, 2002, and declared an official method of the IULTCS in May 2003.

IULTCS, originally formed in 1897, is a world-wide organization of professional leather societies to further the advancement of leather science and technology. IULTCS has three Commissions, which are responsible for establishing international methods for the sampling and testing of leather. ISO recognizes IULTCS as an international standardizing body for the preparation of test methods for leather.

Leather — Physical and mechanical tests — Determination of water repellency of garment leather

1 Scope

This International Standard specifies a method for determining the repellency of leather to surface wetting. It is applicable to all leathers intended for use in clothing. The method does not determine the resistance of leather to water penetration.

2 Normative references

The following referenced documents are indispensable for the application of this document. For dated references, only the edition cited applies. For undated references, the latest edition of the referenced document (including any amendments) applies.

ISO 2418, *Leather — Chemical physical and mechanical and fastness tests — Sampling location*

ISO 2419, *Leather — Physical and mechanical tests — Sample preparation and conditioning*

ISO 3696, *Water for analytical laboratory use — Specification and test methods*

3 Terms and definitions

For the purposes of this document, the following terms and definitions apply.

3.1

spray rating

measure of the resistance of the surface of a leather to wetting

4 Principle

A specified volume of distilled or deionized water is sprayed onto a test piece, which has been mounted on a ring and placed at an angle of 45° so that the centre of the test piece is at a specified distance below the spray nozzle. The spray rating is determined by comparing the appearance of the test piece with descriptive and photographic standards. The mass of water absorbed by the test piece is determined by weighing before and after applying the water spray.

5 Apparatus

5.1 Spray device, as shown in Figure 1, consisting of a funnel, diameter $150 \text{ mm} \pm 2 \text{ mm}$, held vertically with a metal spray nozzle (5.2) connected to the end of the stem by flexible tubing of bore about 10 mm. The overall distance from the top of the funnel to the bottom of the nozzle is $190 \text{ mm} \pm 2 \text{ mm}$.

Dimensions in millimetres

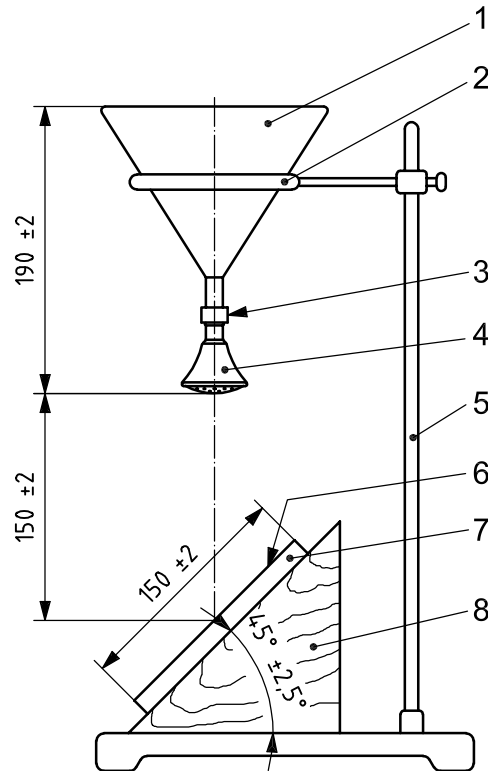

Key

- 1 glass funnel $\varnothing 150 \pm 2$
- 2 ring support
- 3 rubber tubing
- 4 spray nozzle
- 5 stand
- 6 specimen
- 7 specimen holder
- 8 support (e.g. wood)

Figure 1 — Apparatus for spray test

5.2 Metal spray nozzle, as shown in Figure 2, with approximate diameter of 33 mm, having a convex face with 19 holes of $0,9 \text{ mm} \pm 0,05 \text{ mm}$ diameter distributed over the face of the nozzle. The duration of flow for $250 \text{ ml} \pm 5 \text{ ml}$ of distilled or deionized water poured into the funnel shall be $27,5 \text{ s} \pm 2,5 \text{ s}$.

Dimensions in millimetres

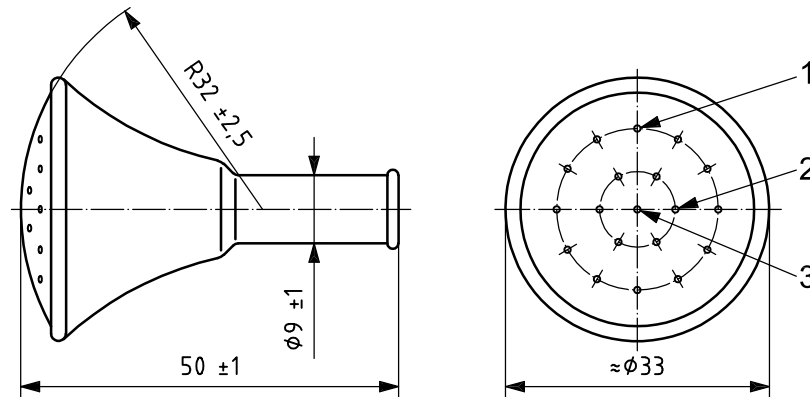

Key

- 1 12 holes $\varnothing 0,9 \pm 0,05$ on a circle $\varnothing 21,4 \pm 0,05$
- 2 6 holes $\varnothing 0,9 \pm 0,05$ on a circle $\varnothing 10 \pm 0,05$
- 3 1 hole $\varnothing 0,9 \pm 0,05$ on centre

Figure 2 — Spray nozzle

5.3 Test piece holder, consisting of two metal rings which fit into each other. The inner ring is fixed and of outside diameter $150 \text{ mm} \pm 2 \text{ mm}$. The outer ring is adjustable so that the internal diameter can be reduced to 150 mm to allow the test piece to be securely clamped between the two rings. When in position for test, the rings rest on a suitable support so that the test piece is at an angle of $45,0^\circ \pm 2,5^\circ$ and with the centre of the clamped area $150 \text{ mm} \pm 2 \text{ mm}$ below the centre of the face of the metal nozzle.

5.4 Balance, reading to $0,001 \text{ g}$.

5.5 Distilled or deionized water, conforming to the requirements of grade 3 of ISO 3696.

6 Sampling and sample preparation

6.1 Sample in accordance with ISO 2418. Cut three square test pieces of side $182 \text{ mm} \pm 2 \text{ mm}$ ensuring that they are taken from areas free from any holes or other damage.

NOTE 1 It may be necessary to trim the wool if a woolled sheepskin is being tested to allow secure clamping of the test piece.

NOTE 2 If there is a requirement for more than two hides or skins to be tested in one batch, then only one sample need be taken from each hide or skin, provided that the overall total is not less than three test pieces.

6.2 Condition the test pieces in accordance with ISO 2419.

6.3 Weigh the test piece to the nearest $0,001 \text{ g}$.

6.4 Carry out all further operations at a temperature of $20^\circ \text{C} \pm 2^\circ \text{C}$ or $23^\circ \text{C} \pm 2^\circ \text{C}$. There is no need for further humidity control.

7 Procedure

7.1 Mount the test piece securely on the test piece holder (5.3) with the face of the leather which would be exposed in wear uppermost. Place the test piece holder in position below the spray nozzle.

7.2 Pour 250 ml \pm 5 ml of distilled or deionized water (5.5) at the controlled temperature (6.4) into the funnel quickly but steadily so that the spraying is continuous once it has commenced.

7.3 Immediately after the spraying has ceased, remove the holder and test piece and tap two diametrically opposite points of the frame against a solid object, with the plane of the leather almost horizontal and the tested surface downwards.

7.4 Assign to the test piece the spray rating on either the following descriptive scale or the photographic scale in Annex A which best describes the degree of wetting. Intermediate ratings are not to be attempted.

- 1 Wetting of the whole of the sprayed surface.
- 2 Wetting of half of the sprayed surface. This usually occurs through the merging of small, discrete wetted areas.
- 3 Wetting of the sprayed surface only as small discrete areas.
- 4 No wetting of, but adherence of small drops to, the sprayed surface.
- 5 No wetting of and no adherence of small drops to the sprayed surface.

7.5 Examine the reverse side of the test piece and note any wetting.

7.6 Remove the test piece from the holder, blot gently to remove any water droplets which still adhere and re-weigh to the nearest 0,001 g.

8 Expression of results

Calculate the mass of water absorbed, m_w , in grams and the percentage of water absorbed, w , using the equations:

$$m_w = m_2 - m_1$$

$$w = \frac{(m_2 - m_1)}{m_1} \times 100 \%$$

where

m_1 is the initial mass of the test piece, in grams;

m_2 is the mass of the test piece after the test, in grams.

9 Test report

The test report shall include the following for each test piece:

- a) a reference to this International Standard; i.e. 17231:2006;
- b) the spray rating (7.4);
- c) the mass of water absorbed, m_w , in grams;
- d) the percentage of water absorbed, w ;
- e) the standard atmosphere used for conditioning and testing as given in ISO 2419 (i.e. 20 °C/65 % RH, or 23 °C/50 % RH);
- f) any deviations from the method specified in this International Standard;
- g) full details for identification of the sample and any deviations from ISO 2418 with respect to sampling.

Annex A
(normative)

ISO photographic scale

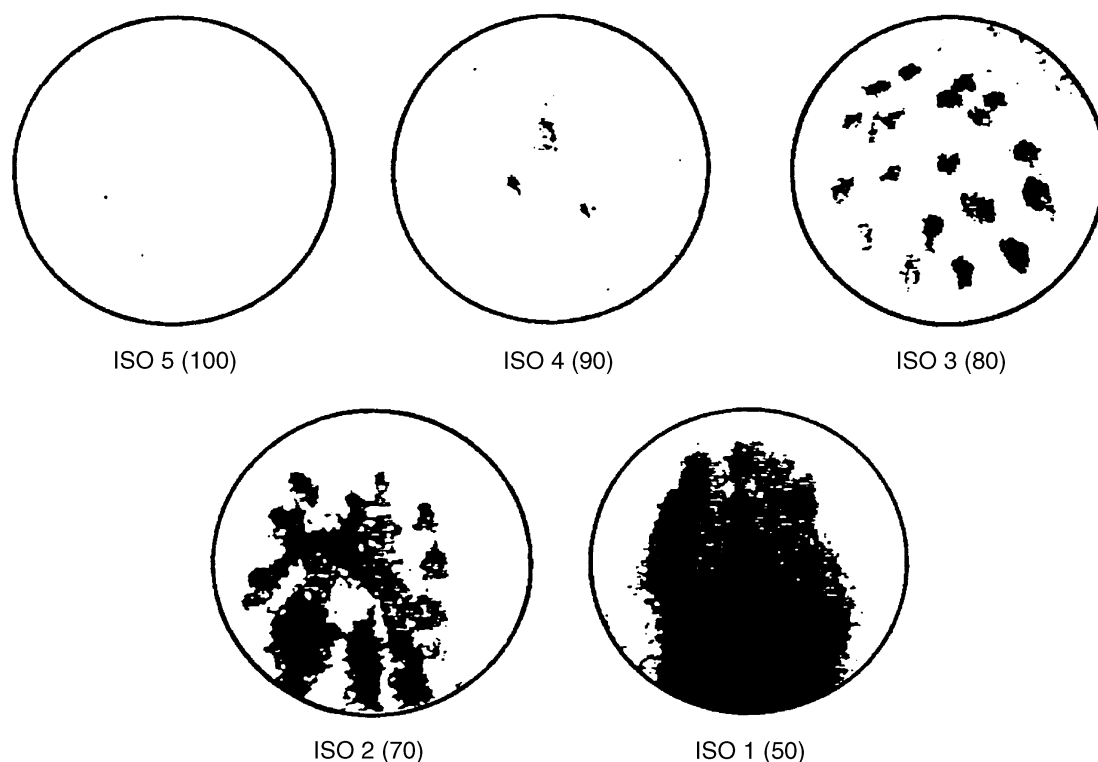

Figure A.1 — ISO spray test rating chart based on the American Association of Textile Chemists and Colorists (AATCC) photographic scale

NOTE The ISO descriptive scale corresponds to the AATCC photographic scale as follows:

ISO 1 = AATCC 50	Wetting of the whole of the sprayed surface.
ISO 2 = AATCC 70	Wetting of half of the sprayed surface. This usually occurs through the merging of small, discrete wetted areas.
ISO 3 = AATCC 80	Wetting of the sprayed surface only as small discrete areas.
ISO 4 = AATCC 90	No wetting of, but adherence of small drops to, the sprayed surface.
ISO 5 = AATCC 100	No wetting of and no adherence of small drops to the sprayed surface.

Annex B (informative)

Sources of apparatus

Examples of suitable products available commercially are given below.

The recommended apparatus is the spray rating tester, manufactured, for example by:

James H. Heal and Co. Ltd¹⁾, Richmond Works, Halifax, West Yorkshire, HX3 6EP, England;

SDL International Ltd¹⁾, PO Box 162, Crown Royal, Shawcross St., Stockport, SK1 3JW, England.

Copies of the AATCC Standard Spray Test Ratings Chart may be obtained from the American Association of Textile Chemist and Colorists, P O Box 12215, Research Triangle Park, NC 27709, USA.

1) James H. Heal and Co. Ltd and SDL International Ltd are an examples of suppliers of a suitable products available commercially. This information is given for the convenience of users of this International Standard and does not constitute an endorsement by ISO of their products.

British Standards Institution (BSI)

BSI is the national body responsible for preparing British Standards and other standards-related publications, information and services.

BSI is incorporated by Royal Charter. British Standards and other standardization products are published by BSI Standards Limited.

About us

We bring together business, industry, government, consumers, innovators and others to shape their combined experience and expertise into standards-based solutions.

The knowledge embodied in our standards has been carefully assembled in a dependable format and refined through our open consultation process. Organizations of all sizes and across all sectors choose standards to help them achieve their goals.

Information on standards

We can provide you with the knowledge that your organization needs to succeed. Find out more about British Standards by visiting our website at bsigroup.com/standards or contacting our Customer Services team or Knowledge Centre.

Buying standards

You can buy and download PDF versions of BSI publications, including British and adopted European and international standards, through our website at bsigroup.com/shop, where hard copies can also be purchased.

If you need international and foreign standards from other Standards Development Organizations, hard copies can be ordered from our Customer Services team.

Subscriptions

Our range of subscription services are designed to make using standards easier for you. For further information on our subscription products go to bsigroup.com/subscriptions.

With **British Standards Online (BSOL)** you'll have instant access to over 55,000 British and adopted European and international standards from your desktop. It's available 24/7 and is refreshed daily so you'll always be up to date.

You can keep in touch with standards developments and receive substantial discounts on the purchase price of standards, both in single copy and subscription format, by becoming a **BSI Subscribing Member**.

PLUS is an updating service exclusive to BSI Subscribing Members. You will automatically receive the latest hard copy of your standards when they're revised or replaced.

To find out more about becoming a BSI Subscribing Member and the benefits of membership, please visit bsigroup.com/shop.

With a **Multi-User Network Licence (MUNL)** you are able to host standards publications on your intranet. Licences can cover as few or as many users as you wish. With updates supplied as soon as they're available, you can be sure your documentation is current. For further information, email bsmusales@bsigroup.com.

BSI Group Headquarters

389 Chiswick High Road London W4 4AL UK

Revisions

Our British Standards and other publications are updated by amendment or revision.

We continually improve the quality of our products and services to benefit your business. If you find an inaccuracy or ambiguity within a British Standard or other BSI publication please inform the Knowledge Centre.

Copyright

All the data, software and documentation set out in all British Standards and other BSI publications are the property of and copyrighted by BSI, or some person or entity that owns copyright in the information used (such as the international standardization bodies) and has formally licensed such information to BSI for commercial publication and use. Except as permitted under the Copyright, Designs and Patents Act 1988 no extract may be reproduced, stored in a retrieval system or transmitted in any form or by any means – electronic, photocopying, recording or otherwise – without prior written permission from BSI. Details and advice can be obtained from the Copyright & Licensing Department.

Useful Contacts:

Customer Services

Tel: +44 845 086 9001

Email (orders): orders@bsigroup.com

Email (enquiries): cservices@bsigroup.com

Subscriptions

Tel: +44 845 086 9001

Email: subscriptions@bsigroup.com

Knowledge Centre

Tel: +44 20 8996 7004

Email: knowledgecentre@bsigroup.com

Copyright & Licensing

Tel: +44 20 8996 7070

Email: copyright@bsigroup.com



...making excellence a habit.™