

Acoustics — Noise from shooting ranges —

Part 2: Estimation of muzzle blast and projectile sound by calculation

The European Standard EN ISO 17201-2:2006 has the status of a
British Standard

ICS 97.220.10; 95.020; 17.140.20

National foreword

This British Standard was published by BSI. It is the UK implementation of EN ISO 17201-2:2006.

The UK participation in its preparation was entrusted by Technical Committee EH/1, Acoustics, to Subcommittee EH/1/3, Residential and industrial noise.

A list of organizations represented on EH/1/3 can be obtained on request to its secretary.

This publication does not purport to include all the necessary provisions of a contract. Users are responsible for its correct application.

Compliance with a British Standard cannot confer immunity from legal obligations.

This British Standard was published under the authority of the Standards Policy and Strategy Committee on 30 November 2006

© BSI 2006

ISBN 0 580 49766 6

Amendments issued since publication

Amd. No.	Date	Comments

ICS 97.220.10; 95.020; 17.140.20

English Version

Acoustics - Noise from shooting ranges - Part 2: Estimation of muzzle blast and projectile sound by calculation (ISO 17201-2:2006)

Acoustique - Bruit des stands de tir - Partie 2: Estimation de la détonation à la bouche et du bruit du projectile par calcul (ISO 17201-2:2006)

Akustik - Geräusche von Schießplätzen - Teil 2: Bestimmung des Mündungsknalls und des Geschossgeräusches durch Berechnung (ISO 17201-2:2006)

This European Standard was approved by CEN on 5 June 2006.

CEN members are bound to comply with the CEN/CENELEC Internal Regulations which stipulate the conditions for giving this European Standard the status of a national standard without any alteration. Up-to-date lists and bibliographical references concerning such national standards may be obtained on application to the Central Secretariat or to any CEN member.

This European Standard exists in three official versions (English, French, German). A version in any other language made by translation under the responsibility of a CEN member into its own language and notified to the Central Secretariat has the same status as the official versions.

CEN members are the national standards bodies of Austria, Belgium, Cyprus, Czech Republic, Denmark, Estonia, Finland, France, Germany, Greece, Hungary, Iceland, Ireland, Italy, Latvia, Lithuania, Luxembourg, Malta, Netherlands, Norway, Poland, Portugal, Romania, Slovakia, Slovenia, Spain, Sweden, Switzerland and United Kingdom.



EUROPEAN COMMITTEE FOR STANDARDIZATION
COMITÉ EUROPÉEN DE NORMALISATION
EUROPÄISCHES KOMITEE FÜR NORMUNG

Management Centre: rue de Stassart, 36 B-1050 Brussels

Foreword

This document (EN ISO 17201-2:2006) has been prepared by Technical Committee ISO/TC 43 "Acoustics" in collaboration with Technical Committee CEN/TC 211 "Acoustics", the secretariat of which is held by DS.

This European Standard shall be given the status of a national standard, either by publication of an identical text or by endorsement, at the latest by January 2007, and conflicting national standards shall be withdrawn at the latest by January 2007.

According to the CEN/CENELEC Internal Regulations, the national standards organizations of the following countries are bound to implement this European Standard: Austria, Belgium, Cyprus, Czech Republic, Denmark, Estonia, Finland, France, Germany, Greece, Hungary, Iceland, Ireland, Italy, Latvia, Lithuania, Luxembourg, Malta, Netherlands, Norway, Poland, Portugal, Romania, Slovakia, Slovenia, Spain, Sweden, Switzerland and United Kingdom.

Endorsement notice

The text of ISO 17201-2:2006 has been approved by CEN as EN ISO 17201-2:2006 without any modifications.

INTERNATIONAL
STANDARD

ISO
17201-2

First edition
2006-07-01

**Acoustics — Noise from shooting
ranges —**

**Part 2:
Estimation of muzzle blast and projectile
sound by calculation**

Acoustique — Bruit des stands de tir —

*Partie 2: Estimation de la détonation à la bouche et du bruit du projectile
par calcul*



Reference number
ISO 17201-2:2006(E)

Contents

Page

Foreword.....	iv
Introduction	v
1 Scope	1
2 Normative references	1
3 Terms and definitions.....	1
3.1 General.....	1
3.2 Directivity.....	5
3.3 Energy.....	5
3.4 Fraction.....	7
3.5 Projectile.....	7
4 Estimation model for source data of the muzzle blast	8
4.1 General.....	8
4.2 Estimation of chemical energy.....	9
4.3 Estimation of acoustic energy.....	9
4.4 Estimation of the Weber energy.....	9
4.5 Estimation of directivity	9
4.6 Estimation of the spectrum	9
5 Estimation model for projectile sound	10
5.1 General.....	10
5.2 Estimation of projectile sound source energy	11
6 Sound exposure.....	12
7 Uncertainty of estimation.....	15
Annex A (informative) Simple blast model for estimation of sound energy and its spectrum	16
Annex B (informative) Quality of input data	18
Annex C (informative) Examples for estimation of muzzle blast.....	21
Annex D (informative) Estimation of sound exposure of projectile according to Figure 3 flowchart — Example.....	29
Bibliography	31

Foreword

ISO (the International Organization for Standardization) is a worldwide federation of national standards bodies (ISO member bodies). The work of preparing International Standards is normally carried out through ISO technical committees. Each member body interested in a subject for which a technical committee has been established has the right to be represented on that committee. International organizations, governmental and non-governmental, in liaison with ISO, also take part in the work. ISO collaborates closely with the International Electrotechnical Commission (IEC) on all matters of electrotechnical standardization.

International Standards are drafted in accordance with the rules given in the ISO/IEC Directives, Part 2.

The main task of technical committees is to prepare International Standards. Draft International Standards adopted by the technical committees are circulated to the member bodies for voting. Publication as an International Standard requires approval by at least 75 % of the member bodies casting a vote.

Attention is drawn to the possibility that some of the elements of this document may be the subject of patent rights. ISO shall not be held responsible for identifying any or all such patent rights.

ISO 17201-2 was prepared by Technical Committee ISO/TC 43, *Acoustics*, Subcommittee SC 1, *Noise*.

ISO 17201 consists of the following parts, under the general title *Acoustics — Noise from shooting ranges*:

- *Part 1: Determination of muzzle blast by measurement*
- *Part 2: Estimation of muzzle blast and projectile sound by calculation*
- *Part 4: Prediction of projectile sound*

The following parts are under preparation:

- *Part 3: Guidelines for sound propagation calculations*
- *Part 5: Noise management*

The initiative to prepare a standard on impulse noise from shooting ranges was taken by AFEMS, the Association of European Manufacturers of Sporting Ammunition, in April 1996, by the submission of a formal proposal to CEN. After consultation in CEN in 1998, CEN/TC 211, *Acoustics*, asked ISO/TC 43/SC 1, *Noise*, to prepare the ISO 17201 series.

Introduction

Two basic sources dominate the shooting sound from firearms: the muzzle blast and the projectile sound. These two sources are basically different. The explosion blast from devices can be treated as muzzle blast.

The muzzle blast is caused by the expanding gases of the propellant at the muzzle. The muzzle blast can be modelled based on essentially less spherical volume of these gases at that moment when the expansion speed becomes subsonic.

The projectile sound is caused by the supersonic flight of the projectile along the trajectory from the muzzle to the target or to a point on the trajectory where the projectile speed becomes subsonic. The projectile sound stems from a section of the trajectory that coherently radiates a shock wave into a certain direction.

In general, the procedures for estimating the source energy depends on the estimation of energies that are involved in related processes. The procedures give estimates for the fraction of these energies that transforms into acoustic energy. The result of the estimation is a set of acoustical source data with respect to energy, direction and frequency content.

Acoustics — Noise from shooting ranges —

Part 2:

Estimation of muzzle blast and projectile sound by calculation

1 Scope

This part of ISO 17201 specifies methods for estimating the acoustic source data of muzzle blast and explosions and the source data of projectile sound on the basis of non-acoustic data for firearms with calibres less than 20 mm and explosions less than 50 g TNT equivalent.

This part of ISO 17201 addresses those cases where no source measurements exist or where the data necessary to calculate projectile sound according to ISO 17201-4 are unknown. An example of this situation would be measuring projectile sound from shot guns pellets. This part of ISO 17201 can also be used as an interpolation method between measurements of muzzle blast.

Source data are given in terms of spectral angular source energy covering the frequency range from 12,5 Hz to 10 kHz and can be used as data input for sound propagation calculation.

This part of ISO 17201 is not applicable to the prediction of sound levels for the assessment of hearing damage and cannot be used to predict sound pressure levels or sound exposure levels below a specific distance where linear acoustics does not apply.

2 Normative references

The following referenced documents are indispensable for the application of this document. For dated references, only the edition cited applies. For undated references, the latest edition of the referenced document (including any amendments) applies.

ISO 17201-1:2005, *Acoustics — Noise from shooting ranges — Part 1: Determination of muzzle blast by measurement*

ISO 17201-4, *Acoustics — Noise from shooting ranges — Part 4: Prediction of projectile sound*

3 Terms and definitions

For the purposes of this document, the terms and definitions given in ISO 17201-1 and the following apply.

3.1 General

3.1.1

air density

ρ

density of air for the estimation conditions

NOTE The air density is expressed in kilograms per cubic metre (kg/m³).

3.1.2
angular frequency

ω
frequency multiplied by 2π

NOTE The angular frequency is expressed in radians per second (rad/s) in all formulae.

3.1.3
coordinate system (x, y)

plane coordinate system describing geometry, where the x -axis denotes the line of fire with $x = 0$ at the muzzle, and the y -axis measures the perpendicular distance from the line of fire in any plane around the line of fire

NOTE 1 The sound field of projectile sound is rotational symmetric around the line of fire.

NOTE 2 The coordinates are given in metres (m).

3.1.4
cosine-coefficients

$c_{1,2,\dots,N}$
coefficients of the cosine-transform used to describe the directivity of the angular source energy

3.1.5
deceleration angle

ε
difference between the radiation angle at the beginning and end of a part of the trajectory

NOTE The deceleration angle is expressed in radians (rad) in all formulae.

3.1.6
specific chemical energy

u
specific chemical energy content of the propellant

NOTE The specific chemical energy is usually expressed in joules per kilogram (J/kg)

3.1.7
line of fire

continuation of the axis of the barrel

See Figure 1.

NOTE Ballistic trajectories can be described as a sequence of straight lines. Then the methods apply to each segment. Corrections of the aiming device are ignored.

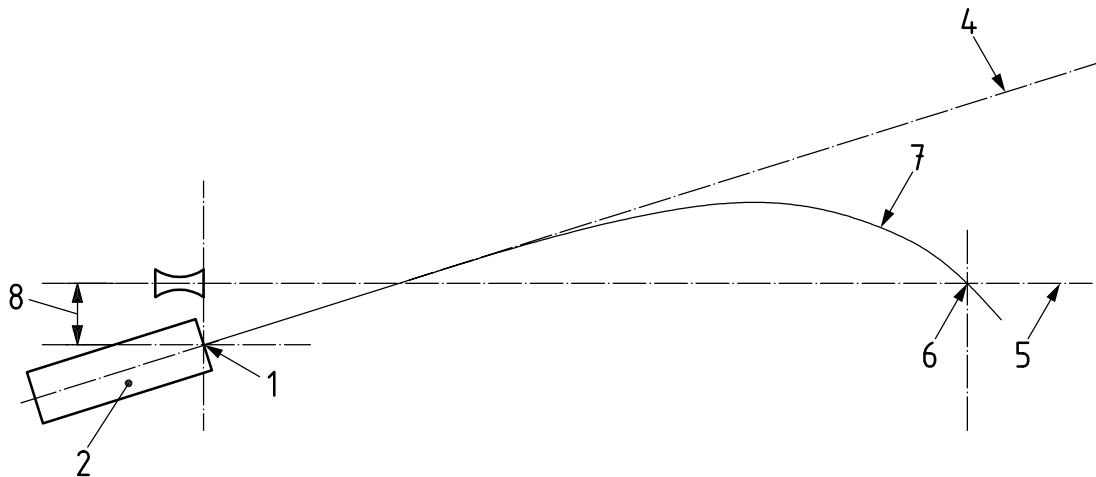

a) Side or elevation view



b) Top or plan view

Key

- 1 muzzle
- 2 barrel
- 3 sight
- 4 line of fire
- 5 line of sight
- 6 target
- 7 trajectory
- 8 height of sight

Figure 1 — Line of fire and line of sight**3.1.8****projectile sound source energy**

Q_p
acoustic energy from a trajectory length of one metre

NOTE 1 The projectile sound source energy is expressed in joules (J).

NOTE 2 See also 3.3.6.

3.1.9**propellant mass**

m_c
mass of the propellant

NOTE The propellant mass is expressed in kilograms (kg).

**3.1.10
radiation angle**

ξ
angle between the line of fire and the wave number vector describing the local direction of the propagation of the projectile sound

NOTE 1 The radiation angle is expressed in radians (rad) in all formulae.

NOTE 2 ξ is the 90° complement of the Mach angle.

**3.1.11
angle alpha**

α
angle between the line of fire and a line from the muzzle to the receiver

NOTE 1 See ISO 17201-1:2005, Figure 3.

NOTE 2 The angle alpha is expressed in radians (rad) in all formulae.

**3.1.12
sound exposure**

E
time integral of frequency-weighted squared instantaneous sound pressure over the event duration time

$$E = \int_T p^2(t) dt$$

NOTE The sound exposure is expressed in pascal-squared seconds (Pa²·s).

**3.1.13
sound exposure level**

L_E
ten times the logarithm to the base 10 of the ratio of the sound exposure to a reference value

NOTE 1 The sound exposure level is expressed in decibels.

NOTE 2 See also ISO 1996-1.

NOTE 3 The sound exposure level of a single burst of sound or transient sound with duration time is given by the formula

$$L_E = 10 \lg \left[\int_T \frac{p^2(t)}{p_0^2 T_0} dt \right] \text{ dB}$$

where

$p(t)$ is the instantaneous sound pressure as a function of time;

$p_0^2 T_0$ is the reference value [(20 μPa)² × 1 s].

**3.1.14
speed of sound in air**

c
speed of sound for the estimation condition

NOTE The speed of sound in air is expressed in metres per second (m/s).

3.1.15 divergent area

S_S

size of the area at a certain distance from the trajectory through which the sound radiated from the respective path of the trajectory is propagating

NOTE The divergent area is expressed in square metres (m²).

3.1.16 propagation distance

r_S

distance between the source point of projectile sound, P_S , and the receiver point, P_R ,

NOTE The propagation distance is expressed in metres (m).

3.1.17 Weber radius

R_W

radius of an equivalent radiating sphere of the “simple model of explosion”

NOTE The Weber radius is expressed in metres (m).

3.1.18 Weber pressure

p_W

sound pressure at the surface of the Weber sphere

NOTE The Weber pressure is expressed in pascals (Pa).

3.2 Directivity

3.2.1 correction factor due to source directivity

c_S

correction taking into account that different orders of Fourier functions contribute differently to the energy

3.2.2 directivity factor

$Y(\alpha)$

directivity function in the direction of α

3.3 Energy

3.3.1 effective angular source energy distribution

$Q_Y(\alpha)$

effective energy radiated into the direction α , weighted by directivity

NOTE The effective angular source energy distribution is expressed in joules per steradian (J/sr).

3.3.2 total acoustic source energy

Q_e

total acoustic energy after integration of $Q_Y(\alpha)$ over the whole sphere

NOTE The total acoustic energy is expressed in joules (J).

**3.3.3
energy in the propellant gas**

Q_g
energy in the gaseous efflux of the propellant at the muzzle

NOTE The energy in the propellant gas is expressed in joules (J).

**3.3.4
kinetic energy loss**

Q_l
difference in projectile energy of the translatory motion on a part of the trajectory of 1 m length due to air drag

NOTE The kinetic energy loss is expressed in joules (J).

**3.3.5
muzzle source energy**

Q_m
total acoustic energy of the muzzle blast

NOTE The muzzle source energy is expressed in joules (J).

**3.3.6
projectile sound source energy**

Q_p
product of the kinetic energy loss, Q_l , and the acoustical efficiency, σ_{ac}

NOTE 1 The projectile sound source energy is expressed in joules (J).

NOTE 2 See also 3.1.8.

**3.3.7
projectile muzzle kinetic energy**

Q_{p0}
kinetic energy of the projectile at the muzzle

NOTE The projectile muzzle kinetic energy is expressed in joules (J).

**3.3.8
propellant energy**

Q_c
total chemical energy of the propellant

NOTE The propellant energy is expressed in joules (J).

**3.3.9
Weber energy density**

Q_w
energy density of a Weber source with a Weber radius of 1 m

NOTE The Weber energy is expressed in joules per cubic metre (J/m³).

**3.3.10
reference Weber energy**

$Q_{w,1}$
Weber energy for a mass of propellant having a Weber radius of 1 m

NOTE The reference Weber energy is expressed in joules (J).

3.3.11 angular source energy distribution

$S_q(\alpha)$
acoustic energy radiated from the source into the far field per unit solid angle

NOTE 1 The acoustic energy radiated by the source within a narrow cone centred around the direction α is

$$S_q(\alpha) = \frac{dQ}{d\Omega}$$

where Ω is the solid angle in steradian (sr).

NOTE 2 The angular source energy distribution is expressed in joules per steradian (J/sr).

3.4 Fraction

3.4.1 kinetic fraction

σ_{cp}
ratio of the projectile kinetic energy, Q_p , to propellant energy, Q_c

NOTE The efficiency is the kinetic fraction, expressed as percentage.

3.4.2 gas fraction

σ_{cg}
ratio of the energy in the exhausted gases, Q_g , of the propellant after the shot to the propellant energy, Q_c

3.4.3 acoustical efficiency

σ_{ac}
ratio of an energy that converts into acoustic energy

3.5 Projectile

3.5.1 projectile diameter

d_p
diameter at the maximum cross section of the projectile

NOTE The projectile diameter is expressed in metres (m).

3.5.2 projectile launch speed

v_{p0}
speed of the projectile at the muzzle

NOTE The projectile launch speed is expressed in metres per second (m/s).

3.5.3 projectile length

l_p
total length of the projectile

NOTE The projectile length is expressed in metres (m).

**3.5.4
projectile mass**

m_p
mass of the projectile, for shotguns the total mass of the pellets

NOTE The projectile mass is expressed in kilograms (kg).

**3.5.5
projectile speed**

v_p
speed of the projectile along the trajectory

NOTE The projectile speed is expressed in metres per second (m/s).

**3.5.6
projectile speed change**

κ
local change of projectile speed along the trajectory per length unit of trajectory

NOTE The projectile speed change is expressed in reciprocal seconds [(m/s)/m = 1/s].

**3.5.7
Mach number**

M
ratio of projectile speed to local sound speed

4 Estimation model for source data of the muzzle blast

4.1 General

If possible, the muzzle blast source data should be determined according to ISO 17201-1.

This clause specifies methods for the estimation of acoustic source data of muzzle blast and explosions. Firearm muzzle blast is highly directive. Both angular source energy distribution and spectrum vary with angle from the line of fire.

For the propagation calculations, frequency and angle-dependent source data are required as input data. Such detailed emission data, measured according to ISO 17201-1, are not readily available for a large variety of weapons and ammunition and there is a need to estimate the data from other technical information. This method may also be applied for explosives. For muzzle blasts, linear acoustics applies if the peak pressure is below 1 kPa.

NOTE This method might not be suitable for firearms fitted with muzzle devices that influence the blast field, for example, a muzzle brake that reduces recoil by deflecting propellant gas flow as it exists from muzzle.

The method is separated in two parts: firstly, the acoustic energy of the shot shall be estimated; secondly, the directional pattern of the source is to be applied and the spectrum calculated. The procedure allows the use of very general data or, if available, specific data to provide a more accurate result. Therefore, the procedure allows the use of alternatives such as default values or specific values for certain parameters.

Due to this flexibility a flow chart is used to describe the steps of the procedure, including equations. In Figure 2 the left part of the flow chart shows how to estimate the muzzle source energy that is to be used in the right part of the flow chart to determine the acoustical source data. Branches in the flow chart that are alternatives are depicted by a logical sign "or", \oplus . The logical sign for "and", \otimes , means that both sets of information are needed to continue. The symbol \hat{x} denotes an default input value for the parameter x . If the parameter x is not known the default value may be used. Numbers at the top of boxes are the equation reference numbers.

The standard-estimation is to be obtained by following the scheme (see Figure 2) along the given default parameters for all coefficients. This estimation is mandatory for the report. If a different value for any coefficient is used the reason for this shall be stated.

4.2 Estimation of chemical energy

The key quantity for estimating the acoustic energy is the total chemical energy involved, Q_c . If Q_c is not known, two alternatives exist for determining Q_c . The left-hand branch uses the kinetic energy of the projectile, Q_{p0} , either known directly or alternatively calculated from the mass and projectile launch speed of the projectile [see Equation (1), in Figure 2]. The projectile energy is a fraction of the total energy. If the fraction σ_{cp} is not known, 35 % should be used as default. Equation (2) in Figure 2 then determines Q_c . The right hand branch uses the mass of propellant or explosives. The impetus (conversion factor), u , depends on the type of propellant (e.g. 4 310 J/kg for TNT, or 5 860 J/kg for PETN). If the specific chemical energy, u , is not known a value of $u = 4\,500$ J/kg should be used.

4.3 Estimation of acoustic energy

The energy Q_c is partially converted into heat and into the kinetic energy of the remaining gas (Q_g), heat and friction between the barrel and projectile, and the kinetic energy of the projectile (Q_{p0}) or accelerated material, respectively. The inner ballistics, in case of guns, will determine this balance^[11]. A fraction of 45 % in Q_c should be used as the default value for Q_g , the only source of energy in the muzzle blast. Equation (5) accounts for the efficiency of the conversion of energy in the propellant gas, Q_g , into the total acoustic energy of the muzzle blast, Q_m .

4.4 Estimation of the Weber energy

The part on the right of Figure 2 shows the flow chart used to determine the Weber energy, Q_W , which is the energy density of a Weber source with the Weber radius of 1 m.

4.5 Estimation of directivity

For rotational symmetric radiation around the line of fire, the directional pattern of the source is described by a Fourier-series with respect to the angle α relative to the line of fire. If the directivity pattern, c_n , is not known, the matrix shown as Equation (6) in Figure 2 gives a list of default values for some weapons. Applying the directivity, Y , to Q_e in Equation (10) in Figure 2 yields the energy that flows through the slice, including the directional pattern of the source.

4.6 Estimation of the spectrum

The next two steps in Equations (11) and (12) in Figure 2 use an acoustical model of explosions in air which allows an estimation of the Fourier-spectrum of the angular source energy distribution, where α is the direction as described in the Annex A, see also Reference [8]. The default values are validated model parameters and should only be changed if relevant information is available. The integral in Equation (12) should be integrated numerically; there is no known analytical solution. This estimation method should not be used for the prediction of peak pressure values or similar quantities.

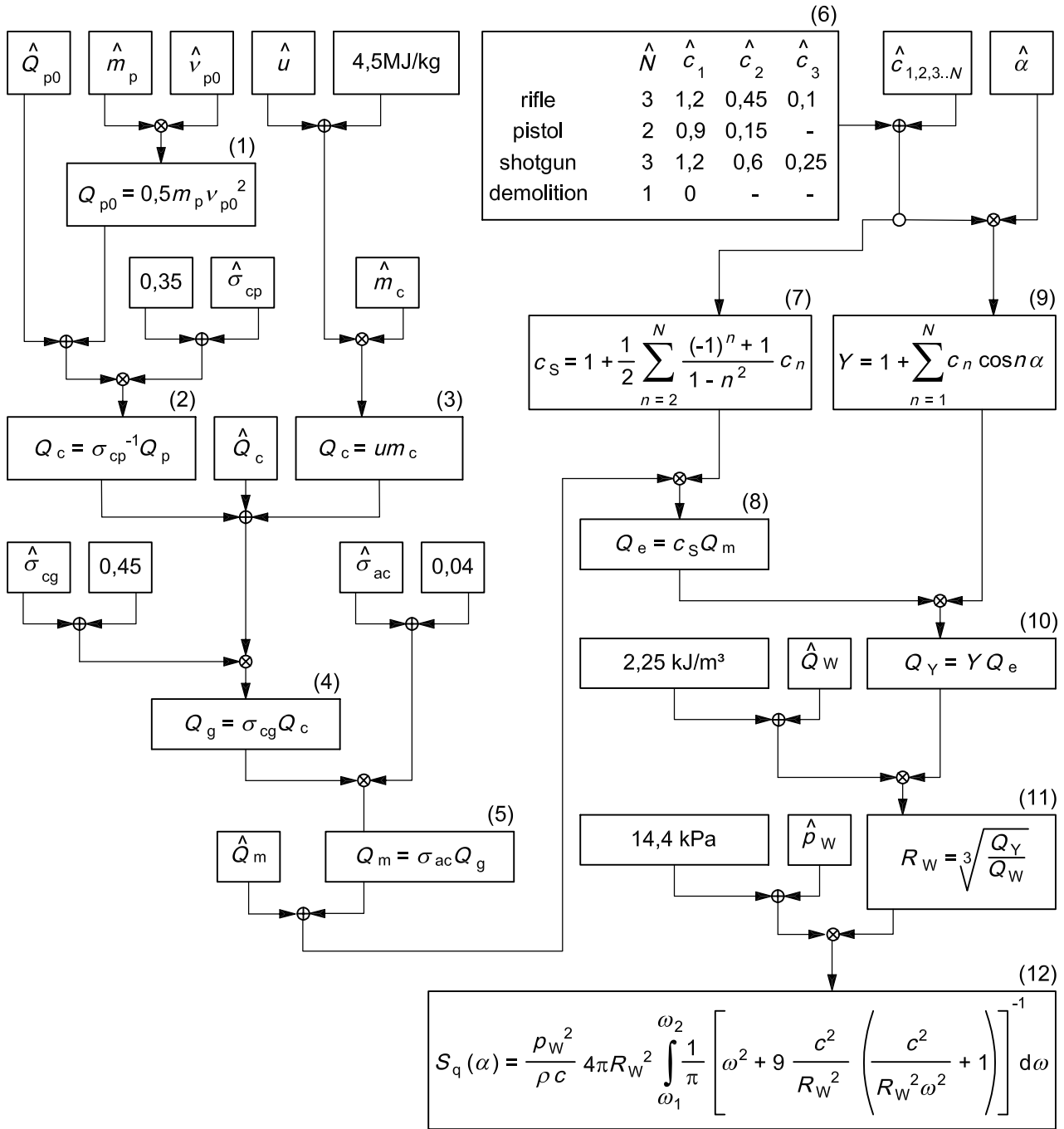

NOTE Numbers at above right of the boxes are the numbers of the equations, as referenced in the text. For additional information with regard to Equations (11) and (12), see Annex A.

Figure 2 — Flow chart of estimation procedure for muzzle blast source data

5 Estimation model for projectile sound

5.1 General

If possible, the projectile sound source data should be determined according to ISO 17201-4.

The free field sound exposure level of projectile sound should be calculated using ISO 17201-4. However, ISO 17201-4 is applicable only if the parameters of the shot are known. If this is not the case the following procedure may be used.

This estimation procedure assumes that a certain portion of the kinetic energy of the projectile moving with supersonic speed is transferred into a shock wave. The method predicts acoustic energy from the shock wave. From this energy the sound exposure is calculated assuming linear acoustics. For N-waves linear behaviour is assumed if the peak pressure is below 100 Pa.

The trajectories are assumed to be a straight line, however, this method also applies to ballistic trajectories which can be approximated by a set of straight lines.

The so-called standard-estimation is obtained by following scheme (see Figure 3) along the given default parameters for all coefficients. This estimation is mandatory for the report. If a different value for any coefficient is used, the reason shall be stated.

5.2 Estimation of projectile sound source energy

Figure 3 shows how to estimate the projectile sound source energy for a shot. The projectile sound source energy, Q_p , is the product of the kinetic energy loss, Q_1 , and the acoustical efficiency, σ_{ac} . If σ_{ac} is known for the projectile under consideration this value should be used, or $\sigma_{ac} = 0,25$ should be used as default.

If κ , v_{p0} and the position of the muzzle are known, the speed and the trajectory of the projectile are known from Equation (13) in Figure 3. Equation (14) gives the loss of kinetic energy per metre. Equation (15) gives the source energy of projectile sound.

NOTE There may be different ways to estimate some of the parameters shown in the flow chart of Figure 3. For example, if the speed of the projectile, v_p , is known at different distances, κ can be estimated using a linear regression.

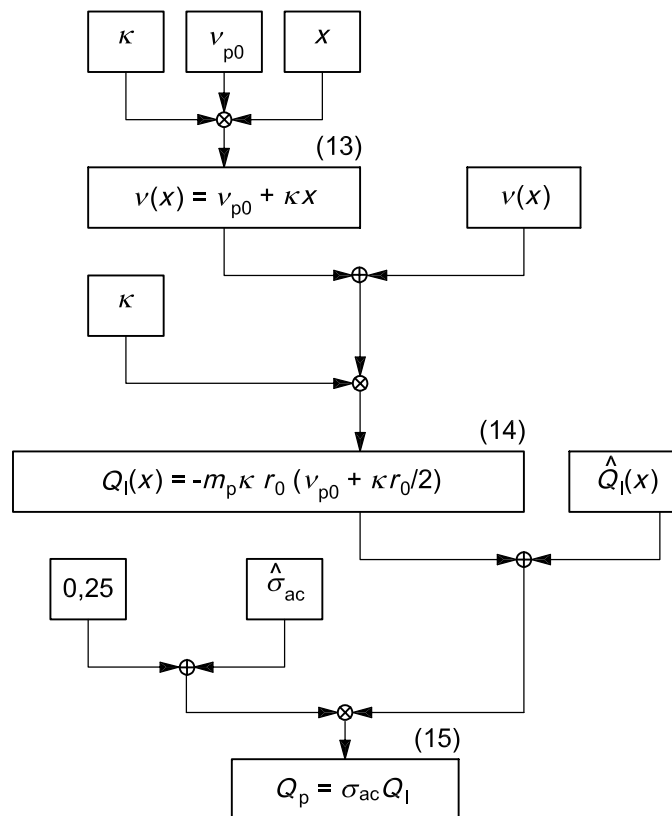

NOTE 1 Numbers at above right of the boxes are the equation numbers, as referenced in the text.

NOTE 2 r_0 is 1 m.

Figure 3 — Flow chart for estimating projectile sound source energy

6 Sound exposure

The sound exposure depends on the path length from the source position to the reception point (see Figure 4):

$$E_S(r_S) = \int p^2(r_S, t) dt \tag{16}$$

where subscript S denotes all parameters which relate the source position on the trajectory to the reception position.

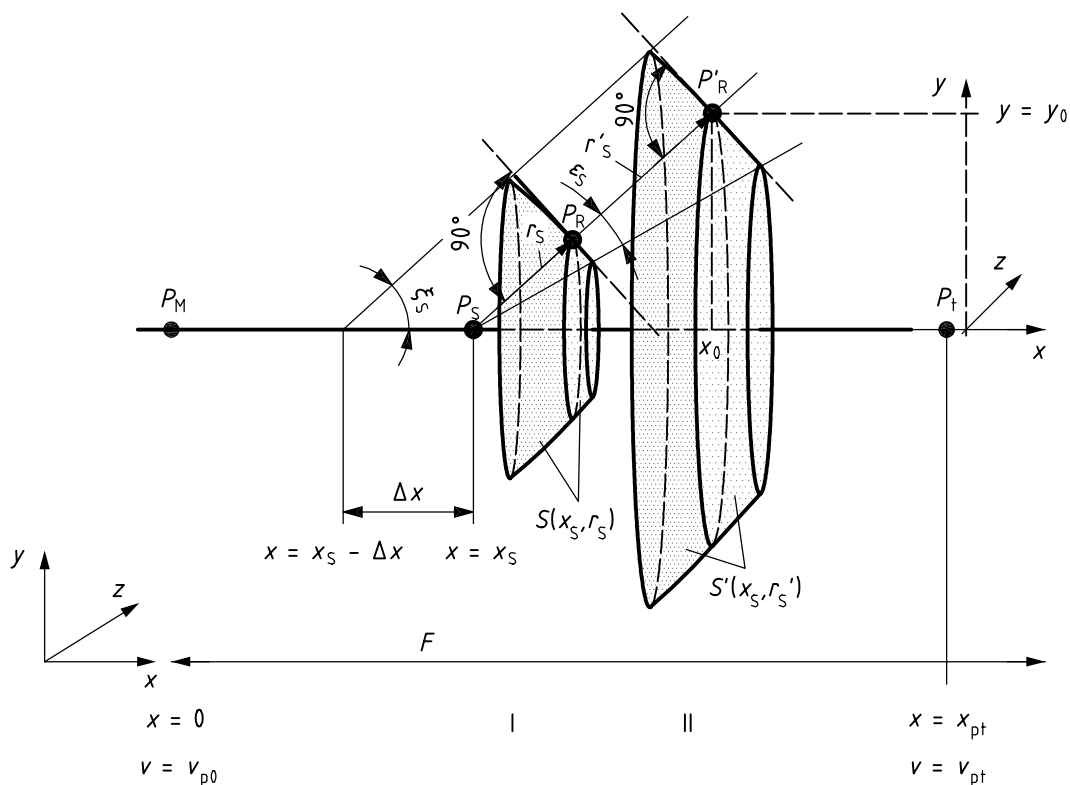

Key

- x line of fire
- y perpendicular direction to the line of fire in any direction around the line of fire
- F trajectory length
- P_M position of the muzzle
- P_t position of target or point on trajectory of fire where projectile becomes subsonic
- P_R reception point

Figure 4 — Shock front geometry for two time periods, I and II

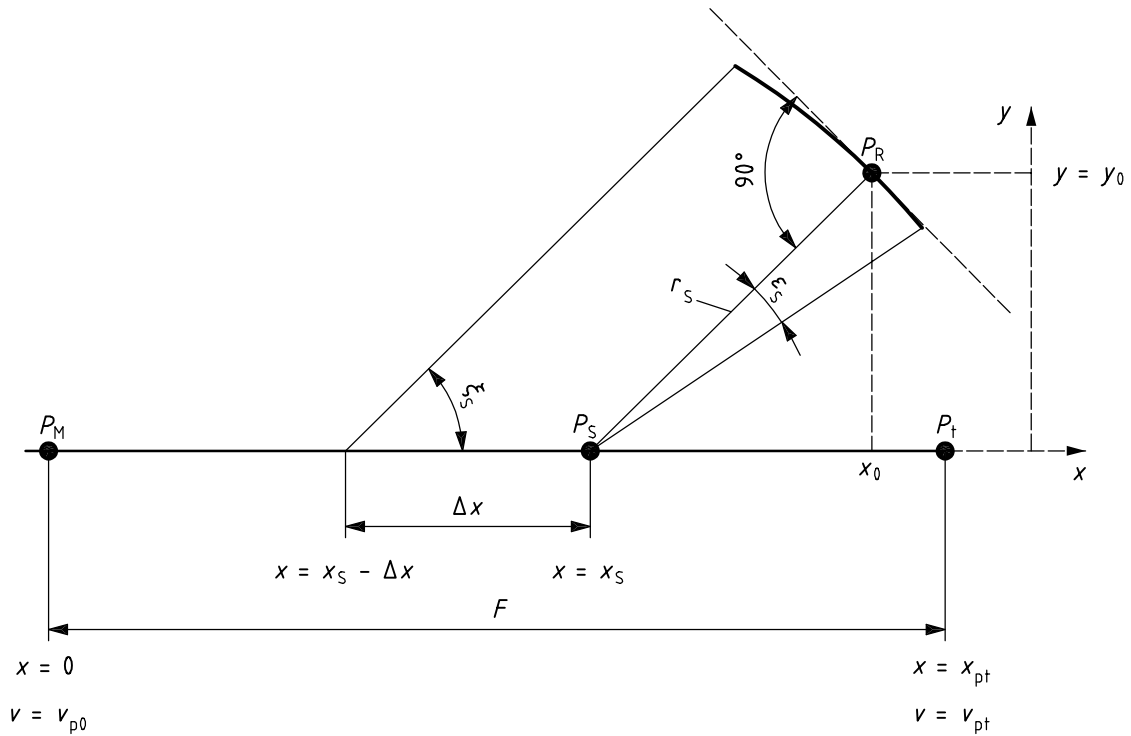

Key

- x line of fire
- y perpendicular direction to the line of fire in any direction around the line of fire
- F trajectory length
- P_M position of muzzle
- P_t position of target or point on trajectory of fire where projectile becomes subsonic
- P_R reception point

NOTE For more information, see Figure 4.

Figure 5 — Shock front geometry at period II

The distance, r_S , shall be sufficiently large to ensure that the peak pressure levels is less than 100 Pa so that linear acoustics apply. Therefore, the estimation of the projectile sound at the source, P_S , at x_S determines the exposure level observed at the reception point, P_R . The sound source energy is proportional to the energy loss at source point, P_S , over a certain length of trajectory. The sound exposure at P_R is inverse proportional to the divergent area, S_S , see Figures 4 and 5 [S_S corresponds to $S(x_S, r_S)$].

For a given reception point P_R , x_S is calculated. In Figure 4 and Figure 5, angle ξ denotes the radiation angle at $x = x_S - \Delta x$. The energy is radiated from the element Δx of the trajectory through the divergent area $S(x_S, r)$ which represents the situation at P_R . Δx is assumed to be 1 m (see Figures 4 and 5).

$$(x_0 - x_S)^2 (v_{p0} + \kappa x_S + c)(v_{p0} + \kappa x_S - c) = c^2 y_0^2 \tag{17}$$

with

$$x < x_S < x_0 \quad \text{and} \quad x_S < \left| \frac{c - v_{p0}}{\kappa} \right| \tag{18}$$

NOTE 1 No analytical solution for x_S is known.

NOTE 2 κ is negative if the projectile is not self-propelled.

From Figure 5, Equation (19) is obtained:

$$r_S = \sqrt{(x_0 - x_S)^2 + y_0^2} \tag{19}$$

The area of divergence S_S is dependent on ξ_S , ε_S and r_S . This area is given by Equation (20):

$$S_S(r_S) = 2\pi\Delta x^2 \left[\sin^2 \xi_S \left(\frac{\cos \xi_S}{2} + \frac{r_S}{\Delta x} \right) + \frac{r_S^2}{\Delta x^2} \sin \left(\xi_S - \frac{\varepsilon_S}{2} \right) \sin \varepsilon_S \right] \tag{20}$$

where

$$\xi_S = \arccos \left(\frac{c}{v_{p,S'}} \right) \tag{21}$$

where $v_{p,S'}$ is the speed of the projectile at point $x_S - \Delta x$.

$$\varepsilon_S = \arccos \left(\frac{c}{v_{p,S'}} \right) - \arccos \left(\frac{c}{v_{p,S}} \right) \tag{22}$$

where

$v_{p,S'}$ is the speed of the projectile at point $x_S - \Delta x$;

$v_{p,S}$ is the speed of the projectile at point x_S .

Then, the sound exposure is given by Equation (23):

$$E_S(r_S) = \rho c \frac{Q_p(\Delta x)}{S_S(r_S)} \tag{23}$$

This estimation is valid as long as the projectile speed is greater than the speed of sound.

As the change of projectile speed is assumed to be linear, $E_S(r_S)$ can be estimated using Equation (24):

$$E_S(r_S) = \rho c \frac{m_p \kappa (v_{p0} + \kappa x_S)^3}{2\pi r_S \sin \xi_S \left[(v_{p0} + \kappa x_S)^2 + \left(\frac{r_S c \kappa}{\sqrt{1 - \frac{c}{v_{p0} + \kappa x_S}}} \right)^2 \right]} \tag{24}$$

NOTE 3 Equation (24) can be applied for Mach numbers greater than 1,01.

NOTE 4 Equation (24) does not depend on the choice of Δx .

The third octave band (nominal mid-band frequency f_i) sound exposure level of the source is given by Equation (25):

$$L_{E,i}(r_S) = 10 \lg \left[\frac{E_S(r_S)}{E_0} \right] \text{ dB} + C_i - C_{\text{tot}} \quad (25)$$

where

$$C_i = 2,5 \text{ dB} + 28 \lg \left(\frac{f_i}{f_c} \right) \text{ dB} \quad \text{if } f_i < 0,65 f_c$$

$$C_i = -5,0 \text{ dB} - 12 \lg \left(\frac{f_i}{f_c} \right) \text{ dB} \quad \text{if } f_i \geq 0,65 f_c$$

$$C_{\text{tot}} = 10 \lg \sum_{i=11}^{40} 10^{C_i/10} \text{ dB}$$

and where

$f_i = 10^{i/10}$ Hz, is the nominal mid-band frequency of the one-third-octave band (12,5 Hz to 10 kHz, $i = 11$ represents a mid-band frequency of 12,5 Hz, and $i = 40$ represents a mid-band frequency of 10 kHz);

f_c is the critical frequency estimated from Equation (26)

$$f_c = \frac{1}{t_{\text{clin}}} \quad (26)$$

where

$$t_{\text{clin}} = 15 \frac{M}{c} \sqrt[3]{\frac{d_p^4}{l_p (M^2 - 1)}} \quad (27)$$

where M is the Mach number.

NOTE 5 The estimation of the spectrum does not yield the dips in the spectra that necessarily occur according to the N-wave one-third octave spectrum. For comparison to experimental data, in particular if the test data include ground reflection, this approach should be considered too simplistic.

NOTE 6 $1/f_c$ describes the N-wave duration.

7 Uncertainty of estimation

The uncertainties of the resulting source data estimations depend on the uncertainties of the values of the acoustic input data. Because of the complexity of the estimation procedures, the uncertainties of the acoustic source data should be estimated by variation of the data to the procedures and observation of the change in the results. In principle, the methods relies on energy concepts. Therefore, the estimation of energy-equivalent acoustic parameters in decibels is less uncertain than the estimation on non-energy-equivalent features. The latter features include the estimation of the directivity of the muzzle blast.

NOTE For each shot of a series, the directivity pattern can vary more significantly than the variation of the acoustical energy of the shots. The procedure result give an average of the pattern.

Annex A (informative)

Simple blast model for estimation of sound energy and its spectrum

The so-called Weber model, published in 1939 [13], has been validated in the acoustic far field for a variety of explosions in air for charge weights, starting at 0,5 g to 20 kg [8], [9].

The model is based on the idea that the source is a spherical volume of compressed gas expanding with high speed. As long as the explosion continues the sphere cannot radiate any sound because the expanding sphere will overtake any sound wave. In this state the volume of the sphere will grow, while the expansion speed will decrease. When the expansion speed equals the speed of sound, the sphere will radiate sound.

This radiation depends on the particle-velocity on the surface of the sphere. The particle velocity equals speed of sound, therefore the radiation per unit area is a constant. The surface of the sphere determines the total radiated acoustic energy.

The differential Equation (A.1) describes the model:

$$\frac{dp(\omega)}{p} = -\alpha(\omega)d\omega \quad (\text{A.1})$$

where ω is the angular frequency.

The function $\alpha(\omega)$ in Equation (A.1) is given by Equation (A.2):

$$\alpha(\omega) = \frac{3c}{R_W} \left[1 + \left(\frac{c}{\omega R_W} \right)^2 \right]^{\frac{1}{2}} \quad (\text{A.2})$$

where

c is the speed of sound;

R_W is the radius of the sphere, the Weber radius of the source.

The time history of the pressure is expressed by Equation (A.3):

$$p(t) = \frac{P_W}{\pi(\alpha^2 + \omega^2)} \int_0^{\infty} \alpha \cos(\omega t) + \omega \sin(\omega t) d\omega \quad (\text{A.3})$$

Equation (A.1) defines the Fourier spectrum of a blast. In order to archive a one-third octave spectrum the Fourier spectrum must be integrated over the range from ω_1 to ω_2 for each one-third octave band defined. Figure A.1 shows an example of a Weber spectrum. Equation (A.1) is a spectrum that is symmetric relative to a centre frequency. However, due to the logarithmic scale of a one-third octave spectrum, the one-third octave spectrum is no longer symmetric. The spectrum follows a 30 dB per frequency decade increase of levels at lower frequencies and a 10 dB per frequency decade decrease for higher frequencies in this one-third octave presentation.

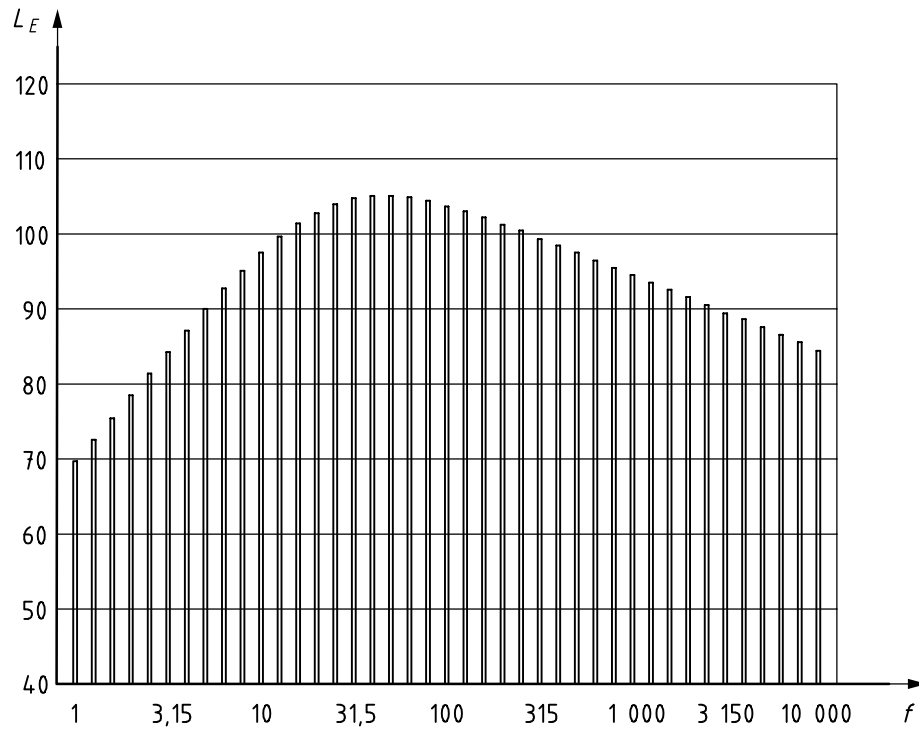

Key

f frequency (Hz)

L_E sound exposure level (dB)

Figure A.1 — One-third octave spectrum of a Weber blast

Annex B (informative)

Quality of input data

B.1 Mass of explosives — Weber radius — Source energy level

Figure B.1 shows an overview of the relationship between the mass of explosives, Weber radius and measured source energy level. It includes firearms and small explosions covered by the scope of this part of ISO 17201. In addition, it gives examples of blasts from devices that are outside the scope of this part of ISO 17201, in order to show the general uncertainty of this dependency. The central straight line is the regression line. The additional lines at both side of the regression line indicate the +3 dB and -3 dB limits of the average.

The three axes at the right of the graph are scales corresponding to the respective source energy level, unweighted, C-weighted and A-weighted.

The abscissa of the graph in Figure B.1 indicates the mass of explosives. For firearms, the effective mass accounts for the directivity of the blast.

The examples in Figure B.1 are results of measurements performed at different distances and heights of the sources. The small arms were fired at a height of approximately 1,5 m at a distance between 7,5 m and 10 m. For the larger weapons, the distance was typically 250 m. As a conclusion, the uncertainty in Figure B.1 is about ± 3 dB.

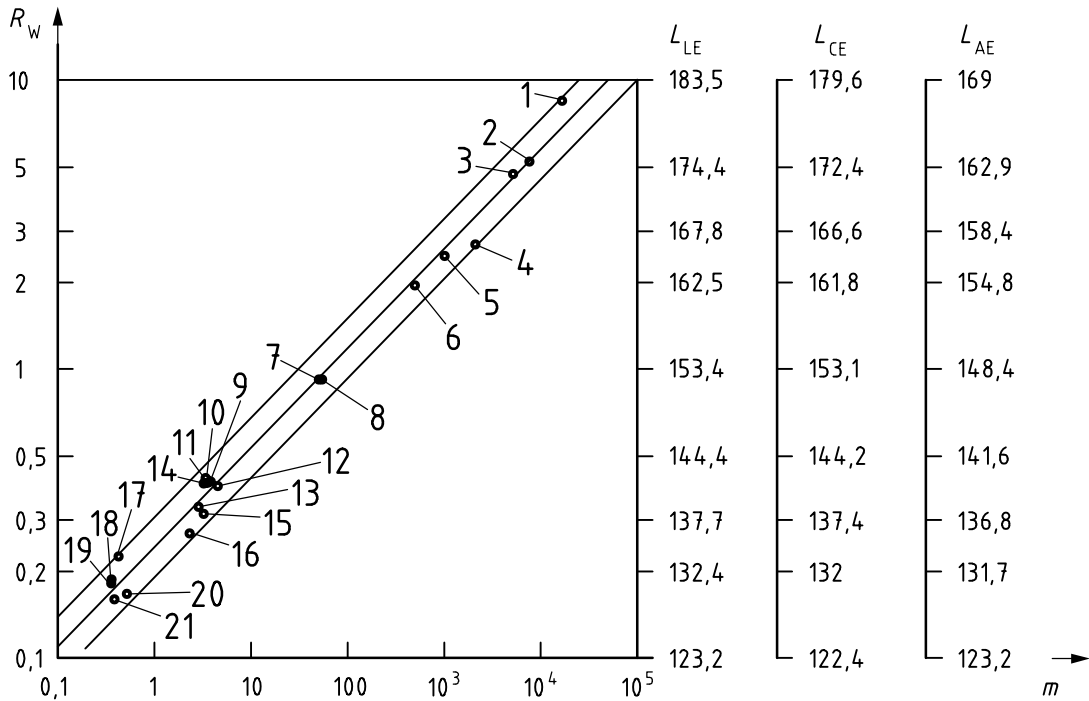

Key

- m effective mass of explosive
- R_w Weber radius (m)
- L_{LE} source energy level, unweighted
- L_{CE} source energy level, C-weighted
- L_{AE} source energy level, A-weighted

- 1 16,5 kg TNT demolition
- 2 120 mm cannon
- 3 105 mm cannon
- 4 155 mm Howitzer 5 GB
- 5 1 kg TNT demolition
- 6 500 g PETN demolition
- 7 149 g simulator demolition
- 8 20 mm machine gun
- 9 .300 hollow point Winchester rifle
- 10 .300 full metal jacket Winchester rifle
- 11 .300 Win magnum rifle
- 12 .300 magnum rifle
- 13 6,5 × 68 mm rifle
- 14 9 mm pistol
- 15 .243 Winchester rifle
- 16 5,6 × 50 mm rifle
- 17 9 mm pistol SIG
- 18 9 mm pistol P1
- 19 9 mm signal pistol
- 20 9 mm submachine gun MP5
- 21 .22 Hornett rifle

Figure B.1 — Weber radius versus effective mass of explosives

B.2 Lateral kinetic energy — Mass of propellant

Figure B.2 shows the correlation between the lateral kinetic energy of the projectile at the muzzle and the mass of propellant for various firearm ammunition. The data were collected from ammunition catalogues [14].

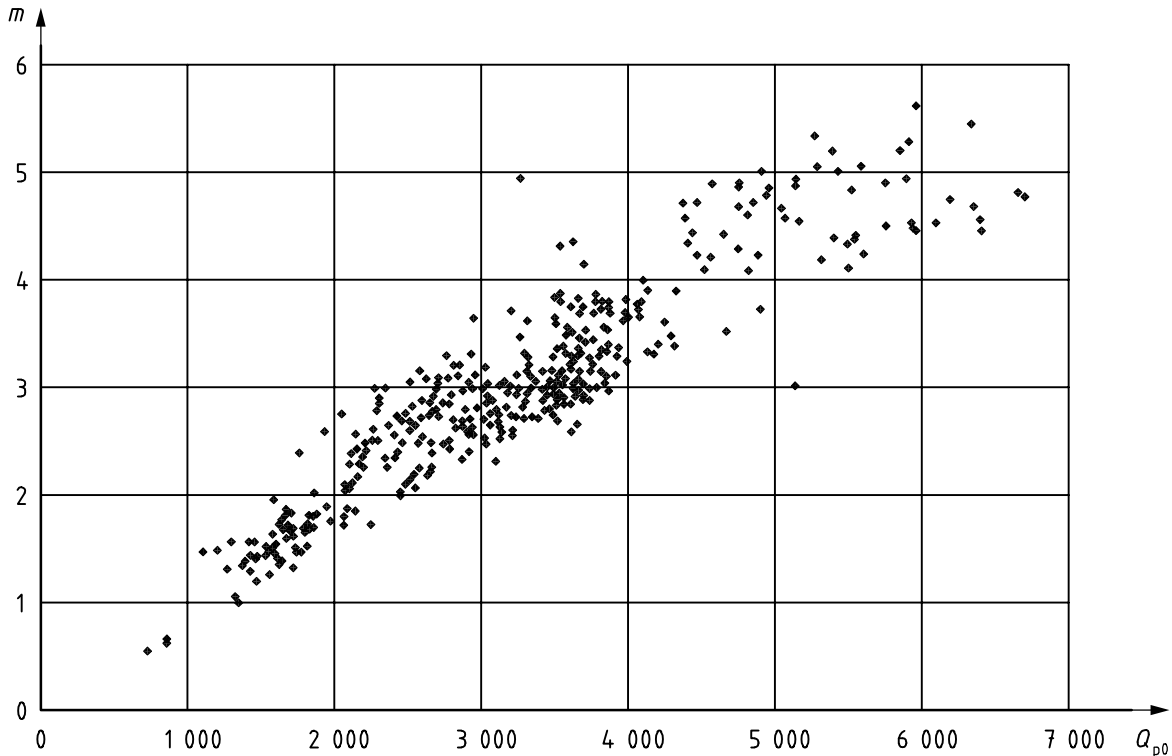

Key

Q_{p0} kinetic energy of projectile (J)

m mass of propellant (g)

Figure B.2 — Mass of propellant versus lateral kinetic energy of the projectile [14]

B.3 Specific chemical energy — Temperature

The efficiency increases approximately 10 % (0,5 dB) for a temperature rise of 50 K.

B.4 Weber radius — Sound exposure measurements

The uncertainty of a description of a measured muzzle blast by the Weber model cannot be expressed by one number for two reasons: Firstly, the Weber radius predicts the complete spectrum but the model is more reliable in some frequency ranges. Secondly, the often present ground reflection and/or projectile sound signature can add uncertainties that are not directly attributable to the uncertainty of the Weber model. For this reason, Annex C focuses on the presentation of these various influences and uncertainties on the determination of a Weber spectrum from a single event measurement. A muzzle blast from a .300 Winchester serves as example (see Annex C).

Annex C (informative)

Examples for estimation of muzzle blast

C.1 Estimation procedure for muzzle blast source data, according to Figure 2 flowchart

C.1.1 Test plan

In accordance with ISO 17201-1, the measurement is as follows.

- a) **Location:** small arms range, two walls on each side, safety baffles across the range.
- b) **Time of measurement:** late September, at noon.
- c) **Terrain:** flat (in the range of 0,1 m), grassy, no rain for at least one day.
- d) **Weather:** sunny, no distinct wind (0 m/s to 2 m/s), low humidity.
- e) **Position of weapon:** centre of measuring half-circle, 1,5 m above local ground, trajectory parallel to the ground, at least 12 m distance to any reflecting obstacle (magnitude of position error vector 0,15 m).
- f) **Measuring positions:** seven quarter-inch microphones on a half-circle at a radius 7,8 m, and at angles of 0°, 30°, 60°, 90°, 120°, 150°, 180° re. trajectory, 1,5 m above local ground, mounted with horizontal membrane (at grazing incidence for direct sound from the muzzle) fixed on the top of wooden poles of 0,04 m diameter (magnitude of position error vector 0,10 m).
- g) **Measuring chain**
Meets requirements of class 1 of IEC 60651 and IEC 61672-2, respectively. Calibration was performed before and after the tests (duration of about 2 h).
- h) **Conduction of measurement**
Shooter fired the rifle aiming at a far distance target at 1,5 m height above ground. The desired position of the muzzle was marked with a pole. The pressure signals of all microphones were simultaneously recorded to a digital tape for later analysis.
- i) **Weapon:** hunting rifle, one barrel, no muzzle brake, brand name is known but omitted here.
- j) **Calibre:** .300 Winchester ¹⁾.
- k) **Ammunition:** propellant mass known but omitted here, projectile (full metal jacket), brand name known but omitted here.
- l) **Reported data**
Time histories of unweighted sound pressure in pascal over a time period of 20 ms:
 - 1) one-third octave spectra of unweighted sound exposure level, region of sonic boom at 0° and 30° was padded to zero for the respective spectra,

1) .300 Winchester is an example of a suitable product available commercially. This information is given for the convenience of users of this part of ISO 17201 and does not constitute an endorsement by ISO of this product.

- 2) propagation corrections for each measuring angle and each third octave,

The propagation correction considers influences from

- ground reflection,
- geometric errors (errors in the relative position between muzzle and ground and receiving microphone and muzzle and receiving microphone),
- timing errors (additional time delays between direct and reflected sound due to local wind and temperature profile), and
- air absorption (calculated for each one-third octave according to ISO 9613-1 or ANSI S1.26-1978, with respect to temperature, ambient pressure and humidity).

C.1.2 Description of procedure to calculate the free field data (see Table C.1)

The procedure for evaluating the propagation correction assumes that the measured pressure at the receiver is the result of the superimposed pressure signals from a direct and reflected blast. The source pressure signals for both components are assumed to be identical Weber radii. In the given range of uncertainties for each geometric parameter, ground impedance and weather condition, the procedure finds the propagation correction by minimising the deviation between the theoretically predicted one-third octave spectra and the measured spectra. These uncertainties are different for each measuring position and single shot. Figure C.1 shows the one-third octave spectra for all seven measuring directions.

C.1.3 Description of procedure for calculating source energy level evaluated on basis of angular source energy

Because of the symmetry of the muzzle blast around the line of fire, the documented results of the seven measuring points on a half circle represent a complete parameter set to evaluate the directivity pattern according to ISO 17201-1. The general cosine transform for this number of points is

$$M(\alpha) = a_0 + a_1 \cos(\alpha) + a_2 \cos(2\alpha) + a_3 \cos(3\alpha) + a_4 \cos(4\alpha) + a_5 \cos(5\alpha) + a_6 \cos(6\alpha) \tag{C.1}$$

$M(\alpha)$ denotes the source energy or source energy level for an arbitrary direction. In Equation (C.2), M_i with $i = 1$ to 7 describes the set of results at the measuring angles, while a_i denotes the respective cosine coefficients.

The matrix represented by Equation (C.2) gives the relationship between the cosine coefficients, a_i , and the M_i (see also Table C.2).

$$\begin{bmatrix} a_0 \\ a_1 \\ a_2 \\ a_3 \\ a_4 \\ a_5 \\ a_6 \end{bmatrix} = \frac{1}{12} \begin{bmatrix} 1 & 2 & 2 & 2 & 2 & 2 & 1 \\ 2 & 2\sqrt{3} & 2 & 0 & -2 & -2\sqrt{3} & -2 \\ 2 & 2 & -2 & -4 & -2 & 2 & 2 \\ 2 & 0 & -4 & 0 & 4 & 0 & -2 \\ 2 & -2 & -2 & 4 & -2 & -2 & 2 \\ 2 & -2\sqrt{3} & 2 & 0 & -2 & 2\sqrt{3} & -2 \\ 1 & -2 & 2 & -2 & 2 & -2 & 1 \end{bmatrix} \begin{bmatrix} M_1 \\ M_2 \\ M_3 \\ M_4 \\ M_5 \\ M_6 \\ M_7 \end{bmatrix} \tag{C.2}$$

Table C.1 — Event levels for single shot from .300 Winchester in seven directions relative to line of fire

Weighting	Measuring quantity	M_1	M_2	M_3	M_4	M_5	M_6	M_7
		0° dB	30° dB	60° dB	90° dB	120° dB	150° dB	180° dB
A	L_q	137,6	135,6	133,7	130,5	128,6	126,1	126,7
	L_E	119,5	117,8	115,9	112,7	110,8	108,3	108,9
	L_{Ep}	121,2	119,7	117,1	114,7	112,0	109,9	109,9
	L_{Em}	121,4	120,1	118,3	115,5	112,0	110,1	109,9
C	L_q	144,6	143,3	141,9	139,2	137,8	135,8	136,2
	L_E	115,8	114,5	113,1	110,4	109,0	107,0	107,4
	L_{Ep}	118,1	116,9	114,7	113,0	110,5	108,6	108,5
	L_{Em}	118,8	117,7	116,0	114,0	110,3	108,9	107,8
Unweighted	L_q	148,1	146,4	144,5	141,3	139,4	136,9	137,6
	L_E	119,3	117,6	115,7	112,5	110,6	108,1	108,8
	L_{Ep}	121,0	119,9	116,9	114,5	111,8	109,6	109,8
	L_{Em}	121,3	120,0	118,2	115,3	111,8	109,9	109,8
Q_d		724,4 J	457,1 J	295,1 J	141,3 J	91,2 J	51,3 J	58,9 J
L_q angular source energy distribution level L_E free field sound exposure level at the receiver L_{Ep} predicted sound exposure level if the ground is present L_{Em} measured sound exposure level M_i set of results at the measuring angles (with $i = 1$ to 7) Q_d energy of an energy-equivalent point source (J)								

Table C.2 — Cosine coefficients for .300 Winchester

Order	0	1	2	3	4	5	6
a' , dB	131,11	5,41	0,45	0,12	0,22	-0,08	0,38
a'' , J	18,9	20,8	8,2	3,4	2,3	2,2	1,7
c	1,0	1,1	0,434	0,18	0,122	0,116	0,09
a' angular source energy level a'' angular source energy c directivity pattern of angular source energy ($c_i = a''/a_0$)							

The source energy evaluated on the basis of the angular source energy is 200,45 J. The source energy level evaluated on the basis of the angular source energy level is 143,020 dB.

The source energy evaluated on the basis of the angular source energy is 200,53 J. The source energy level evaluated on the basis of the angular source energy is 143,022 dB.

The difference between both numbers is 0,002 dB. The source energy level is therefore 143 dB

C.2 Estimation of source energy, according to Figure 2 flowchart, based on mass of propellant

The shot firearm .300 Winchester is used as an example. The estimation will only be based on the mass of propellant 4,5 g which might be typical. The range of used propellant falls between 4 g to 5 g. This measure could have an uncertainty of 10 % if measured. All other data used for this estimation are the default values according to the flow chart.

a) First step: estimation of acoustic energy

$$m_c = 4,5 \text{ g}$$

$$Q_c = 4,5 \text{ MJ/kg} \times 4,5 \text{ g} \cong 20\,300 \text{ J}$$

$$Q_g = 0,45 \times Q_c \cong 9\,135 \text{ J}$$

$$Q_m = 0,04 \times Q_g \cong 365 \text{ J}$$

Q_m is the total acoustic energy that compares to the measured energy of 200,5 J

b) Second step: preparation of directivity correction

The .300 Winchester is a rifle, therefore the default Fourier coefficients for rifles apply.

$$c_s = 1 + 1/2(-2/3 \times 0,45) = 0,85$$

$$Q_e = 0,85 \times 365 \text{ J} \cong 310,25 \text{ J}$$

c) Third step: application of directivity pattern

$$Y(30^\circ) = 1 + 1,2 \cos(30^\circ) + 0,45 \cos(60^\circ) + 0,1 \cos(90^\circ) = 2,264$$

$$Q_Y(30^\circ) = 2,264 \times 310,25 \text{ J} \cong 702,4 \text{ J}$$

$$R_W(30^\circ) = (702 \text{ J} / 2\,250 \text{ J/m}^3)^{1/3} \cong 0,678 \text{ m}$$

d) Fourth step: integration of Weber spectrum

$$1 \text{ Hz to } 10 \text{ kHz: } S_q(\alpha) = \frac{Q}{4\pi}; S_q(30^\circ) = \frac{691,8 \text{ J}}{4\pi} \cong 55,05 \text{ J} \cdot \text{sr}^{-1} \text{ and}$$

$$L_q(\alpha) = 10 \lg \left[\frac{S_q(\alpha)}{S_{q0}(\alpha)} \right] \text{ dB}; L_q(30^\circ) = 10 \lg \left(\frac{55,05 \text{ J} \cdot \text{sr}^{-1}}{10^{-12} \text{ J} \cdot \text{sr}^{-1}} \right) \text{ dB} \cong 137,4 \text{ dB, respectively.}$$

NOTE 1 The calculation uses an air density of 1,29 kg/m³ and a speed of sound of 344 m/s. Be aware that given numbers can change by several millibel if other values are used for these parameters.

NOTE 2 For $L_q(\alpha)$, see ISO 17201-1.

Table C.3 gives examples for two other angles.

Table C.3 — Estimation of source energy level of .300 Winchester ammunition with propellant mass 4,5 g

Quantity	Unit	30°	120°	180°
Y	—	2,264	0,275	0,15
Q_Y	J	702,4	85,3	46,5
R_W	m	0,678	0,336	0,275
Q	J	691,8	83,2	44,7
L_q	dB	137,4	128,2	125,5
Δ	dB	1,8	0,4	-1,2

Δ gives the difference between estimated and measured value.

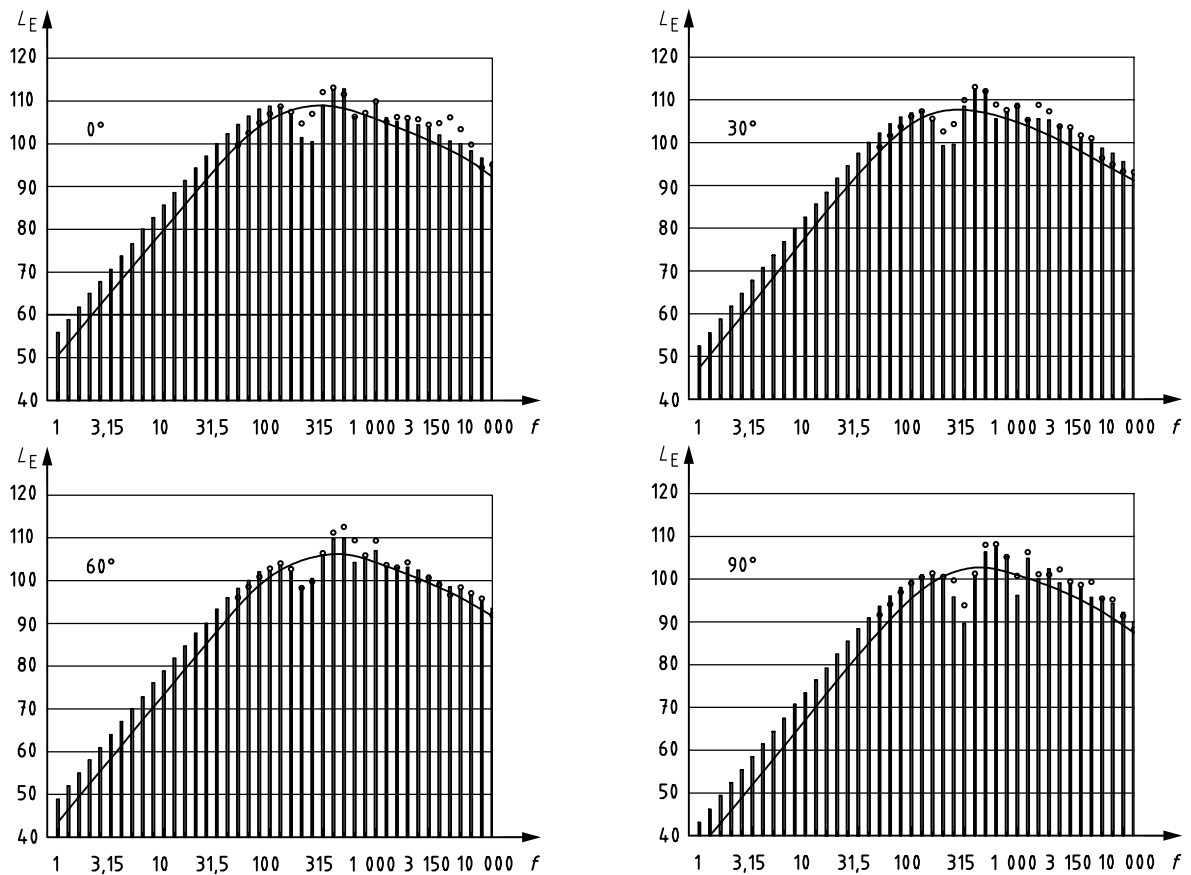
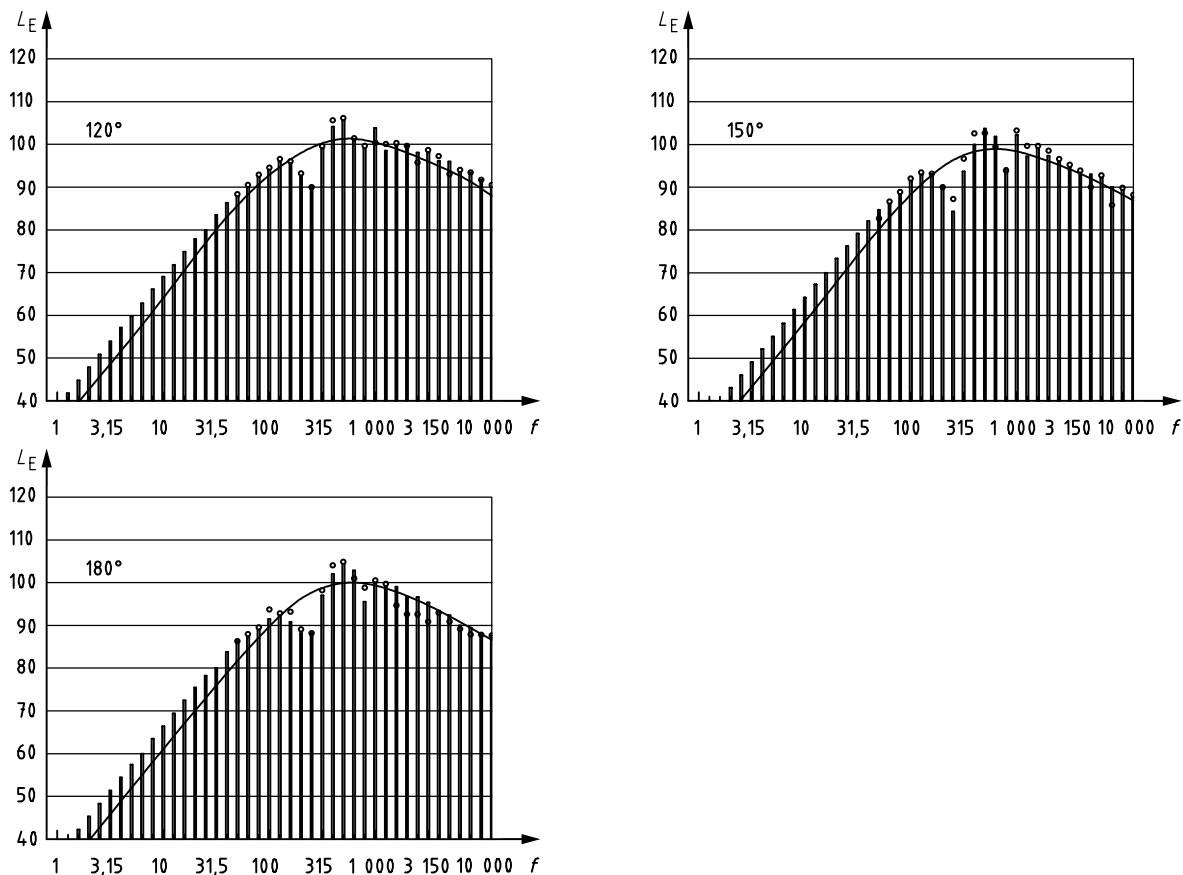

Figure C.1 — One-third octave spectra of muzzle blast from Winchester .300 shot, measured at distance of 7,8 m on half circle around muzzle (see Table C.4)



Key

- f frequency (Hz)
- L_E sound exposure level (dB)
- circles measured sound exposure level
- bars fitted predicted sound exposure level
- solid line free field sound exposure level

Figure C.1 (continued)

Table C.4 — Measured and predicted sound exposure levels from Winchester .300 shot, measured at distance of 7,8 m on half circle around muzzle (see Figure C.1)

Angle °	R_W m	$L_{eq,1s}^a$			$L_{eq,1s}^b$			$L_{eq,1s}^c$		
		Unweighted dB	A dB	C dB	Unweighted dB	A dB	C dB	Unweighted dB	A dB	C dB
0	0,67	121,4	118,8	121,3	121,2	118,1	121,0	119,5	115,8	119,3
30	0,59	120,1	117,7	120,0	119,7	116,9	119,9	117,8	114,5	117,6
60	0,51	118,3	116,0	118,2	117,1	114,7	116,9	115,9	113,1	115,7
90	0,40	115,5	114,0	115,3	114,7	113,0	114,5	112,7	110,4	112,5
120	0,35	112,0	110,3	111,8	112,0	110,5	111,8	110,8	109,0	109,6
150	0,29	110,1	108,9	109,9	109,9	108,6	109,6	108,3	107,0	108,1
180	0,32	109,9	107,8	109,8	109,9	108,5	109,8	108,9	107,4	108,8

NOTE The height of the source and the measurement position are 1,5 m.

^a Measured sound exposure level; the one third-octave-band level are marked in Figure C.1 by circles.
^b Fitted sound exposure level (p*p); the one third-octave-band level are marked in Figure C.1 by bars.
^c Free field sound exposure level (p*v); the one third-octave levels are marked in Figure C.1 by solid lines.

The measured one-third-octave spectra show that the Weber model can generally describe spectra of the muzzle blast from firearm shots. At measurement angles close to the line of fire the approximation is less reliable than for angle to the rear of the weapon. Uncertainties will increase to the front of the weapon. The maximum centre frequency (peak frequency) increases from the front of the weapon (250 Hz) to the rear of the weapon (500 Hz); simultaneously the level decrease from the front to the rear of the weapon.

The method used to analyse the acoustical data in the documentation of the measurement takes into account most of the influences on the measured sound exposure level. The curves include errors of positioning of the weapon and microphones with respect to distances and heights and all influences of weather conditions and the flatness of the test site.

Comparing the curves with each other gives an overview of uncertainties of such a measurement especially in the region of the ground dip (see here at 315 Hz). The difference between the curves get smaller for lower frequencies. Weather conditions and air absorption are not relevant. In all directions, Figure C.2 indicates pressure doubling (−6 dB).

Up to 2 kHz the interference effect dominates the attenuation. For higher frequencies there is only a weak tendency: on the average the measured levels are slightly higher (0 dB to 3 dB) compared to the free field levels.

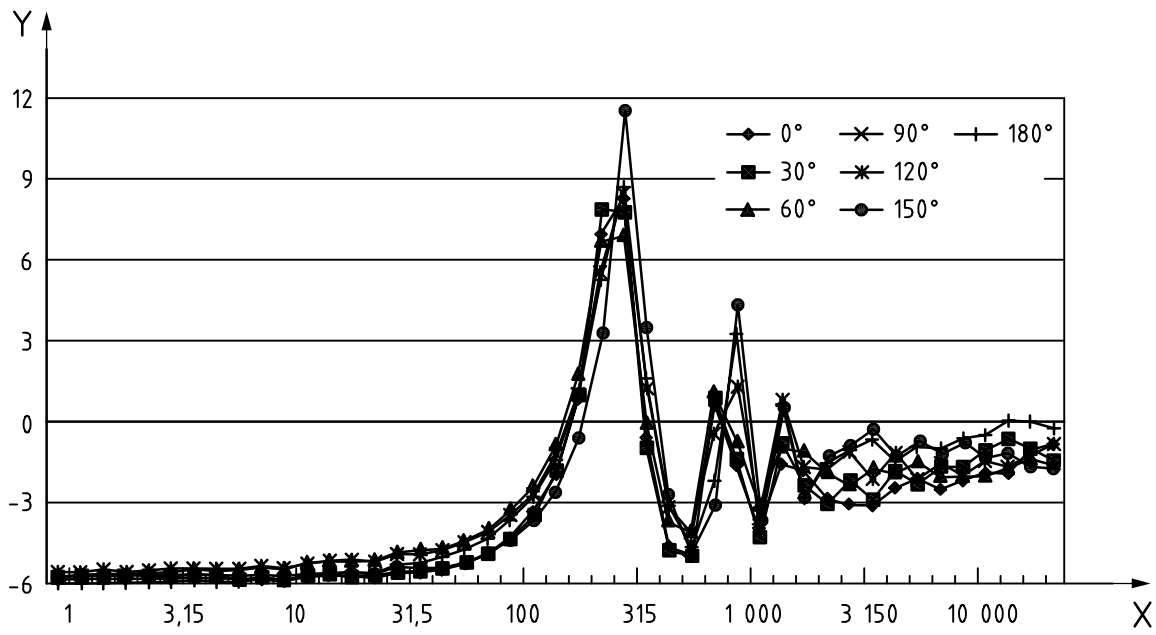

Key
 X frequency f (Hz)
 Y spectral correction (dB)

Figure C.2 — Spectral correction produced for ground effects for each measured direction

Annex D (informative)

Estimation of sound exposure of projectile according to Figure 3 flowchart — Example

A .300 projectile is used as an example. The receiver point for predicting the projectile sound is assumed to be 400 m in front of the muzzle and 400 m aside the line of fire. The estimation will be based on data available from an ammunition catalogue, with the mass of the projectile 11,7 g, its length 31 mm and its speed versus distance according to Table D.1.

Table D.1 — Projectile speed versus distance (taken from an ammunition catalogue)

Distance, m	0	50	100	150	200	300
Speed, m/s	780	740	700	660	625	555

The projectile speed change follows from Table D.1:

$$\kappa = - (780 \text{ m/s} - 555 \text{ m/s}) / 300 \text{ m} = 0,75 \text{ s}^{-1}$$

The launch speed v_{p0} according to Table D.1 is 780 m/s.

Equation (18) yields a solution for the source point at $x = 160 \text{ m}$.

NOTE Kappa results from a linear approach along the entire range given in Table D.1. Therefore, the estimations with Equation (18) do not exactly reproduce the data in the table. For the example given here, Equation (18) yields 660 m/s at 160 m distance instead of 150 m, which indicates the typical uncertainty of the estimation using a linear approach.

The projectile speed at the source point is estimated using Equation (13):

$$\begin{aligned} v(160 \text{ m}) &= 780 \text{ m/s} - 0,75 \text{ s}^{-1} \cdot 160 \text{ m} \\ v(160 \text{ m}) &= 660 \text{ m/s} \end{aligned}$$

Equation (14) yields $Q_1 = 6,84 \text{ J}$.

Equation (15), using the default value for $\sigma_{ac} = 0,25$, yields $Q_p = 1,45 \text{ J}$.

For this example, the assumptions given in Table D.2 apply.

Table D.2 — Assumptions

Quantity	Value
ρ	1,21 kg/m ³
c	340 m/s
x_S	160 m
Δx	10 m
$v(160 \text{ m} - 10 \text{ m}) = 667,5 \text{ m/s}$	

The results are presented in Table D.3.

Table D.3 — Reference to equations and results

Equation	Quantity	Result
19	r_S	466,5 m
21	ξ_S	59,34°
22	ε_S	0,34°
20	S_S	28 700 m ²
23	E_S	0,02 N ² s → 77 dB
Assuming $d_p = 7,8$ mm and $l_p = 31$ mm, the duration of the N-wave is		
27	t_{clin}	0,66 ms
26	f_c	1 500 Hz

Bibliography

- [1] ISO 1996-1, *Acoustics — Description, measurement and assessment of environmental noise — Part 1: Basic quantities and assessment procedures*
- [2] ISO 9613-1:1993, *Acoustics — Attenuation of sound during propagation outdoors — Part 1: Calculation of the absorption of sound by the atmosphere*
- [3] IEC 60651:2001-10, *Sound level meters*
- [4] IEC 60804:2000, *Integrating-averaging sound level meters*
- [5] IEC 61672-1, *Electroacoustics — Sound level meters — Part 1: Specifications*
- [6] IEC 61672-2, *Electroacoustics — Sound level meters — Part 2: Pattern evaluation tests*
- [7] ANSI S1.26-1978, *Method for the calculation of the absorption of sound by the atmosphere*
- [8] HIRSCH, K.-W. *Estimation of acoustical source strength of muzzle blast on the basis of launch speed and bullet weight*, internoise 1999, Fort Lauderdale, USA
- [9] HIRSCH, K.-W. *Estimation of projectile sound*, internoise 2001, The Hague, Netherlands
- [10] HIRSCH, K.-W. *Messung der Emissionsdaten von Mündungsknallen* Schalltechnik'98, Veitshöchheim, 27/28 Mai 1998, Seiten 159 bis 174, ISBN 3-18-091386-x
- [11] KLINGENBERG, G., HEIMERL, J.M., *Gun Muzzle Blast and Flash*, *Progress in Astronautics and Aeronautics*, Volume 139, Am. Inst. of Aeronautics and Astronautics, 1992
- [12] MORFEY, C.L. *Dictionary of Acoustics*, Academic Press, 2001, ISBN 0-12-506940-5
- [13] WEBER, W. *Das Schallspektrum von Knallfunken und Knallpistolen mit einem Beitrag über die Anwendungsmöglichkeiten in der elektroakustischen Messtechnik*; *Akustische Zeitschrift* 4 (1939), pp. 377-391
- [14] *Reloading Guide*, Vihtavuory Oy, *Ammunition Unit*, SF-41330 Vihtavuory, Finland, 1992

BSI — British Standards Institution

BSI is the independent national body responsible for preparing British Standards. It presents the UK view on standards in Europe and at the international level. It is incorporated by Royal Charter.

Revisions

British Standards are updated by amendment or revision. Users of British Standards should make sure that they possess the latest amendments or editions.

It is the constant aim of BSI to improve the quality of our products and services. We would be grateful if anyone finding an inaccuracy or ambiguity while using this British Standard would inform the Secretary of the technical committee responsible, the identity of which can be found on the inside front cover.
Tel: +44 (0)20 8996 9000. Fax: +44 (0)20 8996 7400.

BSI offers members an individual updating service called PLUS which ensures that subscribers automatically receive the latest editions of standards.

Buying standards

Orders for all BSI, international and foreign standards publications should be addressed to Customer Services. Tel: +44 (0)20 8996 9001.
Fax: +44 (0)20 8996 7001. Email: orders@bsi-global.com. Standards are also available from the BSI website at <http://www.bsi-global.com>.

In response to orders for international standards, it is BSI policy to supply the BSI implementation of those that have been published as British Standards, unless otherwise requested.

Information on standards

BSI provides a wide range of information on national, European and international standards through its Library and its Technical Help to Exporters Service. Various BSI electronic information services are also available which give details on all its products and services. Contact the Information Centre.
Tel: +44 (0)20 8996 7111. Fax: +44 (0)20 8996 7048. Email: info@bsi-global.com.

Subscribing members of BSI are kept up to date with standards developments and receive substantial discounts on the purchase price of standards. For details of these and other benefits contact Membership Administration.
Tel: +44 (0)20 8996 7002. Fax: +44 (0)20 8996 7001.
Email: membership@bsi-global.com.

Information regarding online access to British Standards via British Standards Online can be found at <http://www.bsi-global.com/bsonline>.

Further information about BSI is available on the BSI website at <http://www.bsi-global.com>.

Copyright

Copyright subsists in all BSI publications. BSI also holds the copyright, in the UK, of the publications of the international standardization bodies. Except as permitted under the Copyright, Designs and Patents Act 1988 no extract may be reproduced, stored in a retrieval system or transmitted in any form or by any means – electronic, photocopying, recording or otherwise – without prior written permission from BSI.

This does not preclude the free use, in the course of implementing the standard, of necessary details such as symbols, and size, type or grade designations. If these details are to be used for any other purpose than implementation then the prior written permission of BSI must be obtained.

Details and advice can be obtained from the Copyright & Licensing Manager.
Tel: +44 (0)20 8996 7070. Fax: +44 (0)20 8996 7553.
Email: copyright@bsi-global.com.