

# Fishing nets — Method of test for the determination of mesh size

**Part 1: Opening of mesh (ISO  
16663-1:2009)**

ICS 65.150

## National foreword

This British Standard is the UK implementation of EN ISO 16663-1:2009. It is identical to ISO 16663-1:2009. It supersedes BS EN ISO 16663-1:2003 which is withdrawn.

The UK participation in its preparation was entrusted to Technical Committee TCI/77, Ropes and cordage and fishing nets.

A list of organizations represented on this committee can be obtained on request to its secretary.

This publication does not purport to include all the necessary provisions of a contract. Users are responsible for its correct application.

**Compliance with a British Standard cannot confer immunity from legal obligations.**

This British Standard was published under the authority of the Standards Policy and Strategy Committee on 30 April 2009.

© BSI 2009

ISBN 978 0 580 58415 2

### Amendments/corrigenda issued since publication

Date	Comments

English Version

Fishing nets - Method of test for the determination of mesh size -  
Part 1: Opening of mesh (ISO 16663-1:2009)

Filets de pêche - Méthode d'essai pour la détermination  
des dimensions de la maille - Partie 1: Ouverture de maille  
(ISO 16663-1:2009)

Fischnetze - Prüfverfahren zur Bestimmung der  
Maschenweite - Teil 1: Maschenöffnung (ISO 16663-  
1:2009)

This European Standard was approved by CEN on 28 February 2009.

CEN members are bound to comply with the CEN/CENELEC Internal Regulations which stipulate the conditions for giving this European Standard the status of a national standard without any alteration. Up-to-date lists and bibliographical references concerning such national standards may be obtained on application to the CEN Management Centre or to any CEN member.

This European Standard exists in three official versions (English, French, German). A version in any other language made by translation under the responsibility of a CEN member into its own language and notified to the CEN Management Centre has the same status as the official versions.

CEN members are the national standards bodies of Austria, Belgium, Bulgaria, Cyprus, Czech Republic, Denmark, Estonia, Finland, France, Germany, Greece, Hungary, Iceland, Ireland, Italy, Latvia, Lithuania, Luxembourg, Malta, Netherlands, Norway, Poland, Portugal, Romania, Slovakia, Slovenia, Spain, Sweden, Switzerland and United Kingdom.



EUROPEAN COMMITTEE FOR STANDARDIZATION  
COMITÉ EUROPÉEN DE NORMALISATION  
EUROPÄISCHES KOMITEE FÜR NORMUNG

Management Centre: Avenue Marnix 17, B-1000 Brussels

## Foreword

This document (EN ISO 16663-1:2009) has been prepared by Technical Committee ISO/TC 38 "Textiles" in collaboration with Technical Committee CEN/TC 248 "Textiles and textile products", the secretariat of which is held by BSI.

This European Standard shall be given the status of a national standard, either by publication of an identical text or by endorsement, at the latest by September 2009, and conflicting national standards shall be withdrawn at the latest by September 2009.

Attention is drawn to the possibility that some of the elements of this document may be the subject of patent rights. CEN [and/or CENELEC] shall not be held responsible for identifying any or all such patent rights.

This document supersedes EN ISO 16663-1:2003.

According to the CEN/CENELEC Internal Regulations, the national standards organizations of the following countries are bound to implement this European Standard: Austria, Belgium, Bulgaria, Cyprus, Czech Republic, Denmark, Estonia, Finland, France, Germany, Greece, Hungary, Iceland, Ireland, Italy, Latvia, Lithuania, Luxembourg, Malta, Netherlands, Norway, Poland, Portugal, Romania, Slovakia, Slovenia, Spain, Sweden, Switzerland and the United Kingdom.

### Endorsement notice

The text of ISO 16663-1:2009 has been approved by CEN as a EN ISO 16663-1:2009 without any modification.

## Contents

Page

Foreword.....	iv
1 Scope .....	1
2 Normative references .....	1
3 Terms and definitions.....	1
4 Principle.....	2
5 Apparatus .....	2
6 Measurement force .....	4
7 Calibration .....	4
8 Verification of length and force measurement .....	4
9 Requirements for testing .....	5
10 Procedure .....	6
11 Calculation and expression of results.....	7
12 Test report .....	8

## Foreword

ISO (the International Organization for Standardization) is a worldwide federation of national standards bodies (ISO member bodies). The work of preparing International Standards is normally carried out through ISO technical committees. Each member body interested in a subject for which a technical committee has been established has the right to be represented on that committee. International organizations, governmental and non-governmental, in liaison with ISO, also take part in the work. ISO collaborates closely with the International Electrotechnical Commission (IEC) on all matters of electrotechnical standardization.

International Standards are drafted in accordance with the rules given in the ISO/IEC Directives, Part 2.

The main task of technical committees is to prepare International Standards. Draft International Standards adopted by the technical committees are circulated to the member bodies for voting. Publication as an International Standard requires approval by at least 75 % of the member bodies casting a vote.

Attention is drawn to the possibility that some of the elements of this document may be the subject of patent rights. ISO shall not be held responsible for identifying any or all such patent rights.

ISO 16663-1 was prepared by Technical Committee ISO/TC 38, *Textiles*.

This second edition cancels and replaces the first edition (ISO 16663-1:2003), which has been technically revised.

ISO 16663 consists of the following parts, under the general title *Fishing nets — Method of test for the determination of mesh size*:

- *Part 1: Opening of mesh*
- *Part 2: Length of mesh*

# Fishing nets — Method of test for the determination of mesh size —

## Part 1: Opening of mesh

### 1 Scope

This part of ISO 16663 specifies a method for the determination of the size of the mesh opening of fishing nets, using an objective mesh gauge. It is applicable to active and passive fishing gear.

### 2 Normative references

The following referenced documents are indispensable for the application of this document. For dated references, only the edition cited applies. For undated references, the latest edition of the referenced document (including any amendments) applies.

ISO 139, *Textiles — Standard atmospheres for conditioning and testing*

ISO 1107, *Fishing nets — Netting — Basic terms and definitions*

IEC 60529, *Degrees of protection provided by enclosures (IP Code)*

### 3 Terms and definitions

For the purposes of this document, the following terms and definitions apply.

#### 3.1

##### **active fishing gear**

fishing gear requiring movement to catch the fish

NOTE In general, mobile fishing equipment (i.e. equipment which is mobile relative to the sea bed or to the water) is led into the path of the fish to pursue and catch them. All trawls, dredges, seine nets, purse seines and other surrounding nets are examples of active gear.

#### 3.2

##### **trawl**

towed net consisting of a cone-shaped body closed at the rear by a bag or cod end and widened at the opening by wings

NOTE A trawl may be towed by one or two boats and, depending on the type, is used on the bottom or as a midwater (pelagic) trawl.

#### 3.3

##### **Danish seine**

funnel-shaped net (with wings and cod end) with very long ropes laid out on the sea bed and hauled in to a vessel in the open sea

**3.4**  
**purse seine**  
large single-panel multisection net used to encircle pelagic fish, the bottom of the net being drawn together to enclose the encircled fish

**3.5**  
**passive fishing gear**  
fishing gear requiring movement of the fish in order for the fish to be caught

NOTE This gear is usually stationary equipment, often, but not always, anchored on the sea bed. Gill nets and entangling nets are examples of passive gear.

**3.6**  
**gill net**  
panel of netting, usually of rectangular shape, made of thin twine or monofilament yarn, in the meshes of which the fish are caught

NOTE The net is suspended vertically in the water by floats and sinkers.

**3.7**  
**entangling net**  
loosely hung vertical net that catches fish by entangling rather than enmeshing them

**3.8**  
**trammel net**  
bottom-set net which is made up of three walls of netting, the two tightly hung outer walls having a larger mesh size than the inner wall which is loosely hung between them

NOTE The fish pass through one of the outer walls and become entangled in the small meshes of the inner wall, after which they push themselves into the second outer wall, thus forming a bag.

## 4 Principle

An objective mesh gauge is inserted into the mesh opening. The mesh is stretched by a movable jaw until a pre-set measurement force is reached. The size of the mesh opening is then measured automatically.

## 5 Apparatus

**5.1 Objective mesh gauge**, complying with the requirements of 5.1.1 to 5.1.6.

**5.1.1** The objective mesh gauge used for determining mesh openings shall be automatic and electrically driven (see Figure 1). The gauge shall be able to apply selected longitudinal measuring forces, in the range 5 N to 180 N, to the meshes with a precision of 1 N. Fixed measuring forces of 10 N, 20 N, 50 N and 125 N shall be provided. A built-in system for measuring the applied force is needed. The gauge shall have two jaws, one fixed and one movable, each 2 mm thick with rounded edges with a radius of 1 mm, to ensure that the jaws slip easily over the twine or yarn. A mesh shall be stretched at a constant speed of  $(300 \pm 30)$  mm/min by the movable jaw. The gauge shall be able to measure meshes from 10 mm to 300 mm and may have different, detachable, jaws for use on small and large meshes. The measurement precision shall be 1 mm.

**5.1.2** The structure of the gauge shall be rigid and shall not distort under load. The body shall be light yet robust and shall weigh no more than 2,5 kg. The gauge shall be made of materials resistant to corrosion under marine conditions. It shall be water-resistant, be unaffected by dust to rating IP 56 as specified in IEC 60529, and be stable in operation over the temperature range  $-10$  °C to  $+40$  °C. The gauge shall be able to withstand temperatures between  $-25$  °C and  $+65$  °C during storage and transportation.



**5.1.3** Gauge operation shall be controlled by software that provides a menu of functions. It shall be possible to operate the gauge with one hand and the functions shall be accessible via external buttons. Data shall be shown on an integral display able to present each measurement, the number of measurements made in a series and the mean value. A store shall be provided capable of holding at least 1 000 measurements and it shall be possible to transmit data to a computer.

**5.1.4** The software menu shall contain a suitable function to calculate the mean mesh opening, rounded to the nearest 0,1 mm. For so-called “square” meshes, the software shall contain a suitable function to select automatically the longer diagonal of each mesh to calculate the mean mesh opening of the square mesh netting. To allow verification of the selection procedure, the data saved shall include all the measurements made.

**5.1.5** The software shall permit automatic self-testing of the electronic and mechanical parts when the gauge is started. If the gauge is ready for use, this shall be shown on the display. If this is not the case, the display shall show an error message and the gauge shall close down and not be usable.

**5.1.6** Some netting will creep under load. The gauge shall respond to this condition by re-applying the pre-set measurement force in accordance with an algorithm in the controlling software which causes the gauge to

- a) extend the movable jaw into the mesh at a constant speed of  $(300 \pm 30)$  mm/min until the pre-set measurement force is reached;
- b) stop the motor and wait 1 s;
- c) if the force drops below 80 % of the measurement force, extend the jaw into the mesh until the measurement force is reached once more.

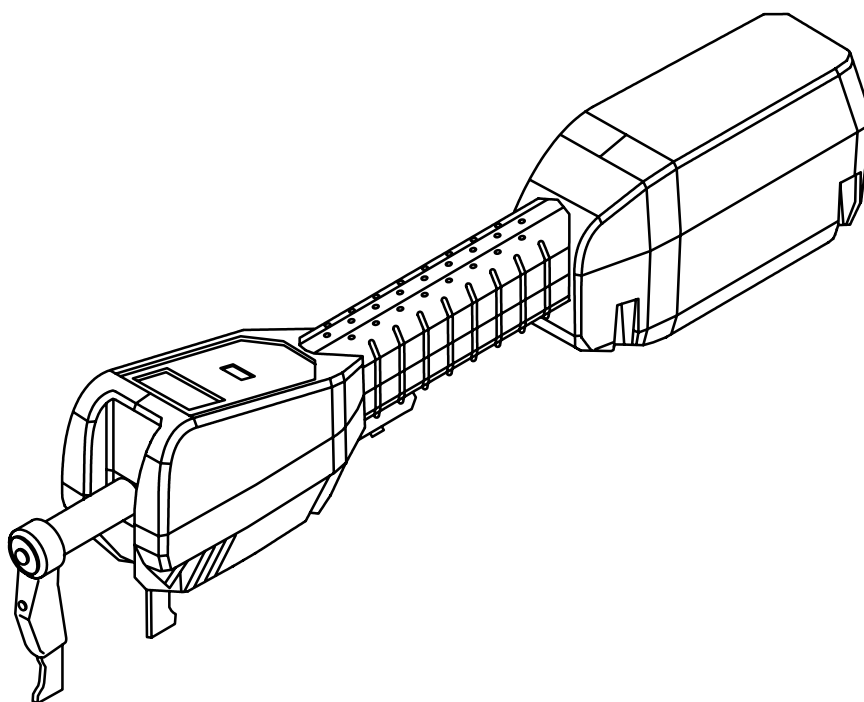

**Figure 1 — Example of an objective mesh gauge**

**5.2** Equipment for producing and maintaining the standard atmosphere for testing.

**5.3** Equipment in which samples can be immersed in water preparatory to wet testing.

## 6 Measurement force

For the netting of active fishing gear, use:

- 20 N for meshes  $< 35$  mm;
- 50 N for meshes  $\geq 35$  mm but  $< 55$  mm;
- 125 N for meshes  $\geq 55$  mm.

For the netting of passive fishing gear, use 10 N for all mesh sizes.

## 7 Calibration

The objective mesh gauge shall be calibrated once a year by an authorized calibration institute.

## 8 Verification of length and force measurement

### 8.1 Verification of length measurement

Verification of the length measurement shall be performed at intervals by inserting the jaws of the gauge into slots of different lengths in a calibrated rigid test plate. An example of such a test plate is shown in Figure 2.

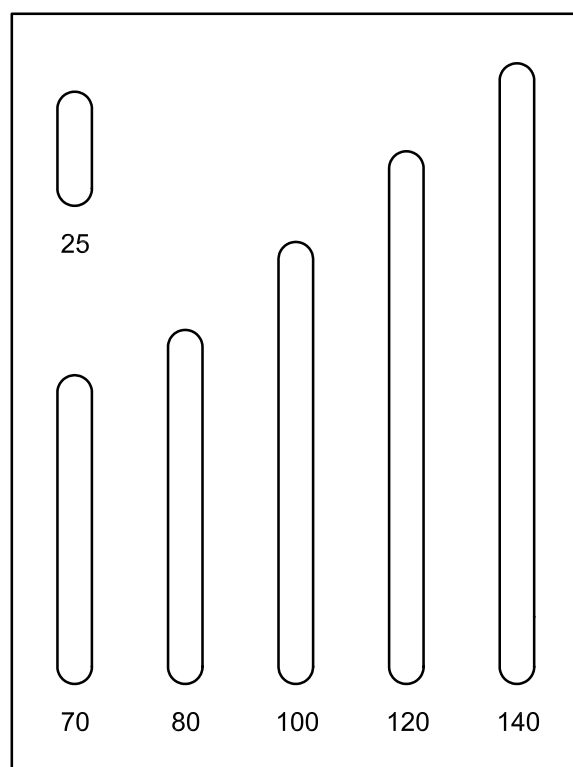
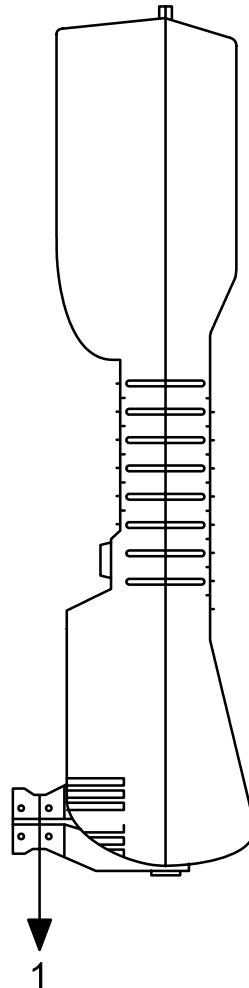

Figure 2 — Test plate

## 8.2 Verification of force measurement

Verification of the force measurement shall be performed at intervals by hanging calibrated weights on the fixed jaw, with the gauge securely held vertically, as shown in Figure 3. The weights shall have the following values: 10 N, 20 N, 50 N and 125 N. Calibration shall only be carried out under stable conditions.



### Key

1 test weight

Figure 3 — Force measurement verification

## 9 Requirements for testing

### 9.1 General

Tests may be carried out in both the dry and wet states, but tests in the wet state are considered to be particularly appropriate in indicating the behaviour of the netting in use.

### 9.2 Atmosphere for testing

All specimens to be tested in the dry state shall be conditioned in the standard atmosphere specified in ISO 139 until they have reached equilibrium. Where it is not possible to carry out the test in the standard atmosphere, the test shall be carried out immediately after removal of the specimen from the standard atmosphere.

### 9.3 Testing in the wet state

Specimens to be tested in the wet state shall be

- a) either immersed in tap water at  $(20 \pm 2)$  °C for not less than 12 h;
- b) or immersed in a solution of wetting agent at  $(20 \pm 2)$  °C for not less than 1 h.

## 10 Procedure

### 10.1 Mesh type

The mesh dimension to be measured depends on the mesh type:

- a) *Diamond mesh*: The netting shall be stretched in the direction of the long axis of the mesh, i.e. the N-direction (see Figure 4). If, in knotless netting, the N-direction cannot be determined, then the mesh shall be measured in the direction of the longer axis of the mesh.
- b) *Square mesh*: The netting shall be stretched first in the direction of one diagonal of the mesh, then in the direction of the other diagonal. The larger measurement shall be taken as the mesh opening.

### 10.2 Preparation of the gauge

**10.2.1** Select, and fit to the gauge, the appropriate size of jaw for the meshes to be measured.

**10.2.2** Ensure that the jaws are clean.

**10.2.3** Start the gauge and allow it to perform the self-check. Select the force to be applied.

**10.2.4** Verify the jaw size setting. The default setting is "normal". If small or large jaws are being used, enter the menu and change the jaw size setting accordingly.

### 10.3 Insertion and operation of the gauge

Hold the gauge in one hand and insert the jaws into the mesh opening with the fixed jaw located at the knot nearest to the operator, as shown in Figure 4.

Activate the gauge and allow the jaws to open until the movable jaw reaches the opposite knot and stops when the pre-set force is reached. Care shall be taken to ensure that the widest opening is measured, i.e. with the jaws at positions located as far into the respective knot as possible, as shown in Figure 4. Use the gauge without any further physical intervention until it has performed the measurement and obtained a final value of the mesh size. Instruct the gauge to accept or reject the measurement (see 10.4). The movable jaw will then be retracted, ready to make the next measurement.

On set nets, it may be more convenient to locate the movable jaw first in the knot furthest from the operator whilst stretching the twine or yarn gently by hand. This alternative procedure shall, however, be carried out with caution as it may result in excess force being applied to the mesh, and the twine or yarn shall be released before the gauge applies the pre-set force to the mesh.

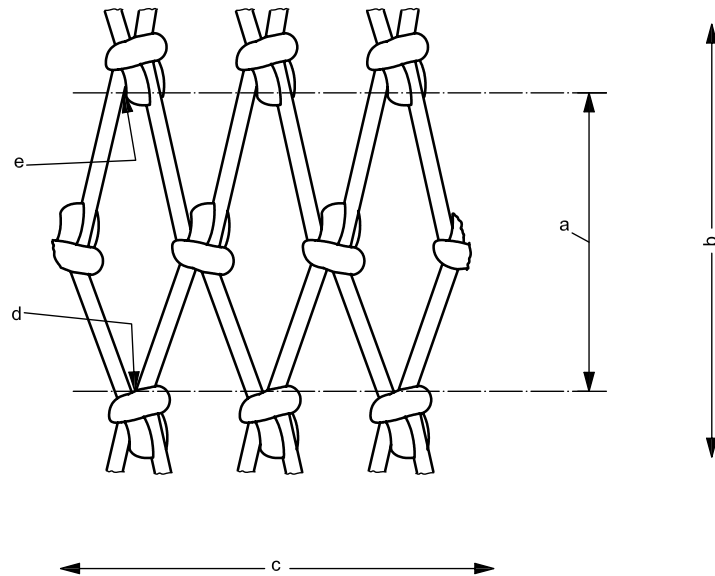

- a Mesh opening.
- b N-direction.
- c T-direction.
- d Fixed jaw inserted at this position.
- e Movable jaw guided to this position.

**Figure 4 — Insertion of the gauge**

#### 10.4 Acceptance of measurement

After making each mesh measurement, it is necessary to decide whether to accept or reject the measurement before saving it in the data store. Possible reasons for rejection are:

- a) the jaws did not locate in the widest opening positions;
- b) the operator lost a firm grip on the gauge or physically interfered with the measurement;
- c) the value indicated is unrealistic.

If the measurement is deemed acceptable, save the reading. If a measurement is deemed unacceptable, but is accepted in error, then cancel the whole series of measurements and start again.

#### 10.5 Number of measurements

Measure a minimum of 20 consecutive meshes.

### 11 Calculation and expression of results

**11.1** After measuring a series of meshes, instruct the gauge to calculate the mean mesh opening. This will be rounded to the nearest 0,1 mm and displayed. Then instruct the gauge to end the sequence of measurements. The data saved will include all accepted measurements, each with the date and time of measurement and a unique identifier.

**11.2** For square meshes, the software automatically selects the longer diagonal of each mesh to calculate the mean mesh size.

## 12 Test report

The test report shall include the following:

- a) a statement that the test was performed in accordance with this part of ISO 16663;
- b) the date of the test;
- c) a description of the netting, including the material and the type of yarn (twisted or braided), the type of netting (knotted or knotless), the mesh size and the nominal linear density of the twine or yarn expressed in accordance with ISO 1107;
- d) the average size of the mesh opening, in millimetres;
- e) the measurement force used;
- f) the number of measurements made;
- g) the state of the netting (dry or wet);
- h) the coefficient of variation of the results and the confidence interval;
- i) details of any deviations from the specified test procedure.



---

## BSI - British Standards Institution

BSI is the independent national body responsible for preparing British Standards. It presents the UK view on standards in Europe and at the international level. It is incorporated by Royal Charter.

### Revisions

British Standards are updated by amendment or revision. Users of British Standards should make sure that they possess the latest amendments or editions.

It is the constant aim of BSI to improve the quality of our products and services. We would be grateful if anyone finding an inaccuracy or ambiguity while using this British Standard would inform the Secretary of the technical committee responsible, the identity of which can be found on the inside front cover. Tel: +44 (0)20 8996 9000. Fax: +44 (0)20 8996 7400.

BSI offers members an individual updating service called PLUS which ensures that subscribers automatically receive the latest editions of standards.

### Buying standards

Orders for all BSI, international and foreign standards publications should be addressed to Customer Services. Tel: +44 (0)20 8996 9001. Fax: +44 (0)20 8996 7001 Email: [orders@bsigroup.com](mailto:orders@bsigroup.com) You may also buy directly using a debit/credit card from the BSI Shop on the Website <http://www.bsigroup.com/shop>

In response to orders for international standards, it is BSI policy to supply the BSI implementation of those that have been published as British Standards, unless otherwise requested.

### Information on standards

BSI provides a wide range of information on national, European and international standards through its Library and its Technical Help to Exporters Service. Various BSI electronic information services are also available which give details on all its products and services. Contact Information Centre. Tel: +44 (0)20 8996 7111 Fax: +44 (0)20 8996 7048 Email: [info@bsigroup.com](mailto:info@bsigroup.com)

Subscribing members of BSI are kept up to date with standards developments and receive substantial discounts on the purchase price of standards. For details of these and other benefits contact Membership Administration. Tel: +44 (0)20 8996 7002 Fax: +44 (0)20 8996 7001 Email: [membership@bsigroup.com](mailto:membership@bsigroup.com)

Information regarding online access to British Standards via British Standards Online can be found at <http://www.bsigroup.com/BSOL>

Further information about BSI is available on the BSI website at <http://www.bsigroup.com>.

### Copyright

Copyright subsists in all BSI publications. BSI also holds the copyright, in the UK, of the publications of the international standardization bodies. Except as permitted under the Copyright, Designs and Patents Act 1988 no extract may be reproduced, stored in a retrieval system or transmitted in any form or by any means – electronic, photocopying, recording or otherwise – without prior written permission from BSI.

This does not preclude the free use, in the course of implementing the standard, of necessary details such as symbols, and size, type or grade designations. If these details are to be used for any other purpose than implementation then the prior written permission of BSI must be obtained.

Details and advice can be obtained from the Copyright and Licensing Manager. Tel: +44 (0)20 8996 7070 Email: [copyright@bsigroup.com](mailto:copyright@bsigroup.com)