

BS EN ISO 16251-1:2014



BSI Standards Publication

# Acoustics — Laboratory measurement of the reduction of transmitted impact noise by floor coverings on a small floor mock-up

Part 1: Heavyweight compact floor

**bsi.**

...making excellence a habit.™

**National foreword**

This British Standard is the UK implementation of EN ISO 16251-1:2014.

The UK participation in its preparation was entrusted to Technical Committee EH/1/6, Building acoustics.

A list of organizations represented on this committee can be obtained on request to its secretary.

This publication does not purport to include all the necessary provisions of a contract. Users are responsible for its correct application.

© The British Standards Institution 2014. Published by BSI Standards Limited 2014

ISBN 978 0 580 73944 6

ICS 91.120.20

**Compliance with a British Standard cannot confer immunity from legal obligations.**

This British Standard was published under the authority of the Standards Policy and Strategy Committee on 31 August 2014.

**Amendments issued since publication**

Date	Text affected
------	---------------

---

ICS 91.120.20

English Version

Acoustics - Laboratory measurement of the reduction of  
transmitted impact noise by floor coverings on a small floor  
mock-up - Part 1: Heavyweight compact floor (ISO 16251-  
1:2014)

Acoustique - Mesurage en laboratoire de la réduction de la  
transmission du bruit de choc par les revêtements de sol  
sur un plancher normalisé de dimensions réduites - Partie  
1: Plancher lourd (ISO 16251-1:2014)

Akustik - Labormessung der Trittschallminderung von  
Deckenauflagen auf kleinflächigen  
Prüfdeckennachbildungen - Teil 1: Schwere Massivdecke  
(ISO 16251-1:2014)

This European Standard was approved by CEN on 28 May 2014.

CEN members are bound to comply with the CEN/CENELEC Internal Regulations which stipulate the conditions for giving this European Standard the status of a national standard without any alteration. Up-to-date lists and bibliographical references concerning such national standards may be obtained on application to the CEN-CENELEC Management Centre or to any CEN member.

This European Standard exists in three official versions (English, French, German). A version in any other language made by translation under the responsibility of a CEN member into its own language and notified to the CEN-CENELEC Management Centre has the same status as the official versions.

CEN members are the national standards bodies of Austria, Belgium, Bulgaria, Croatia, Cyprus, Czech Republic, Denmark, Estonia, Finland, Former Yugoslav Republic of Macedonia, France, Germany, Greece, Hungary, Iceland, Ireland, Italy, Latvia, Lithuania, Luxembourg, Malta, Netherlands, Norway, Poland, Portugal, Romania, Slovakia, Slovenia, Spain, Sweden, Switzerland, Turkey and United Kingdom.



EUROPEAN COMMITTEE FOR STANDARDIZATION  
COMITÉ EUROPÉEN DE NORMALISATION  
EUROPÄISCHES KOMITEE FÜR NORMUNG

**CEN-CENELEC Management Centre: Avenue Marnix 17, B-1000 Brussels**

## Foreword

This document (EN ISO 16251-1:2014) has been prepared by Technical Committee ISO/TC 43 "Acoustics" in collaboration with Technical Committee CEN/TC 126 "Acoustic properties of building elements and of buildings" the secretariat of which is held by AFNOR.

This European Standard shall be given the status of a national standard, either by publication of an identical text or by endorsement, at the latest by February 2015, and conflicting national standards shall be withdrawn at the latest by February 2015.

Attention is drawn to the possibility that some of the elements of this document may be the subject of patent rights. CEN [and/or CENELEC] shall not be held responsible for identifying any or all such patent rights.

According to the CEN-CENELEC Internal Regulations, the national standards organizations of the following countries are bound to implement this European Standard: Austria, Belgium, Bulgaria, Croatia, Cyprus, Czech Republic, Denmark, Estonia, Finland, Former Yugoslav Republic of Macedonia, France, Germany, Greece, Hungary, Iceland, Ireland, Italy, Latvia, Lithuania, Luxembourg, Malta, Netherlands, Norway, Poland, Portugal, Romania, Slovakia, Slovenia, Spain, Sweden, Switzerland, Turkey and the United Kingdom.

### Endorsement notice

The text of ISO 16251-1:2014 has been approved by CEN as EN ISO 16251-1:2014 without any modification.

# Contents

Page

<b>Foreword</b> .....	<b>iv</b>
<b>Introduction</b> .....	<b>v</b>
<b>1 Scope</b> .....	<b>1</b>
<b>2 Normative references</b> .....	<b>1</b>
<b>3 Terms and definitions</b> .....	<b>1</b>
<b>4 Principle</b> .....	<b>2</b>
<b>5 Equipment</b> .....	<b>2</b>
5.1 Test setup.....	2
5.2 Instruments.....	3
<b>6 Test procedure</b> .....	<b>3</b>
6.1 Installing the specimens.....	3
6.2 Placement of tapping machine and accelerometers.....	3
6.3 Frequency range.....	3
6.4 Measurement.....	4
6.5 Evaluation of results.....	4
<b>7 Uncertainty</b> .....	<b>5</b>
<b>8 Expression of results</b> .....	<b>5</b>
<b>9 Test report</b> .....	<b>5</b>
<b>Annex A (normative) Test setup</b> .....	<b>7</b>
<b>Annex B (informative) Design of presentation of results</b> .....	<b>8</b>
<b>Bibliography</b> .....	<b>10</b>

## Foreword

ISO (the International Organization for Standardization) is a worldwide federation of national standards bodies (ISO member bodies). The work of preparing International Standards is normally carried out through ISO technical committees. Each member body interested in a subject for which a technical committee has been established has the right to be represented on that committee. International organizations, governmental and non-governmental, in liaison with ISO, also take part in the work. ISO collaborates closely with the International Electrotechnical Commission (IEC) on all matters of electrotechnical standardization.

The procedures used to develop this document and those intended for its further maintenance are described in the ISO/IEC Directives, Part 1. In particular the different approval criteria needed for the different types of ISO documents should be noted. This document was drafted in accordance with the editorial rules of the ISO/IEC Directives, Part 2 (see [www.iso.org/directives](http://www.iso.org/directives)).

Attention is drawn to the possibility that some of the elements of this document may be the subject of patent rights. ISO shall not be held responsible for identifying any or all such patent rights. Details of any patent rights identified during the development of the document will be in the Introduction and/or on the ISO list of patent declarations received (see [www.iso.org/patents](http://www.iso.org/patents)).

Any trade name used in this document is information given for the convenience of users and does not constitute an endorsement.

For an explanation on the meaning of ISO specific terms and expressions related to conformity assessment, as well as information about ISO's adherence to the WTO principles in the Technical Barriers to Trade (TBT) see the following URL: Foreword - Supplementary information

The committee responsible for this document is ISO/TC 43, *Acoustics*, Subcommittee SC 2, *Building acoustics*.

ISO 16251 consists of the following parts, under the general title *Acoustics — Laboratory measurement of the reduction of transmitted impact noise by floor coverings on a small floor mock-up*:

— *Part 1: Heavyweight compact floor*

## Introduction

The improvement of impact sound reduction is the main quantity for describing the acoustic behaviour of floor coverings. Its determination is described in the ISO 10140<sup>[4]</sup> series and requires the use of a special test facility. This facility consists of two rooms (the lower one of at least 50 m<sup>3</sup>), separated by an approximately 14 cm thick concrete slab or a special timber joist floor. Manufacturers of floor coverings see the advantage of having their own test facilities, but the investment often is not affordable for small- and medium-sized enterprises. This part of ISO 16251 aims to reduce the effort for the determination of the impact sound reduction. A standardized test method is provided, which yields results comparable to those gained with the ISO 10140 series<sup>[4]</sup>.





# Acoustics — Laboratory measurement of the reduction of transmitted impact noise by floor coverings on a small floor mock-up —

## Part 1: Heavyweight compact floor

### 1 Scope

This part of ISO 16251 specifies a laboratory measurement method to determine the improvement of impact sound insulation by a floor covering when laid on a standard concrete floor mock-up and excited by a standard tapping machine. The method is restricted to soft, flexible floor coverings, which transmit impact sound mainly “locally” into the floor, i.e. through the area close to the points of excitation, so that the size of the flooring specimen does not have an influence on the results. Examples of such floor coverings are carpets, PVC, and linoleum. These floor coverings correspond to ISO 10140-1:2010<sup>[5]</sup>, Annex H, category I.

The results only provide information about the noise radiated. A subjective classification of the quality of the floor coverings is not intended.

The method is kept as close as possible to the ISO 10140<sup>[4]</sup> series and yields the same results within the range of uncertainty and within the range of application. In the case of difference with ISO 10140, the result of the ISO 10140 measurement shall be used.

This part of ISO 16251 provides the measurement method. Product test codes can contain further requirements concerning the specimens, such as temperature range, the number of test specimens or special mounting conditions.

**NOTE** If non-soft, non-flexible floorings are tested, e.g. those with a laminated structure, increased deviations from the results of the ISO 10140<sup>[4]</sup> series method may occur due to the dependency on the specimen size.

### 2 Normative references

The following documents, in whole or in part, are normatively referenced in this document and are indispensable for its application. For dated references, only the edition cited applies. For undated references, the latest edition of the referenced document (including any amendments) applies.

ISO 717-2, *Acoustics — Rating of sound insulation in buildings and of building elements — Part 2: Impact sound insulation*

ISO 16063 (all parts), *Methods for the calibration of vibration and shock transducers*

### 3 Terms and definitions

For the purposes of this document, the following terms and definitions apply.

### 3.1 vibratory acceleration level

$L_a$   
value given by Formula (1):

$$L_a = 10 \lg \frac{1}{T_m} \int_0^{T_m} \frac{a(t)^2 dt}{a_0^2} \text{ dB} \quad (1)$$

where  $T_m$  is the integration time, in seconds;  $a$  is the acceleration, in metres per second squared;  $a_0$  is the reference acceleration ( $1 \times 10^{-6} \text{ m/s}^2$ ).

### 3.2 improvement of impact sound insulation

$\Delta L$   
reduction of the vibratory acceleration level resulting from installation of the test floor covering for a given one-third octave band

Note 1 to entry: The improvement of impact sound insulation is expressed in decibels.

### 3.3 locally reacting floor coverings

floor coverings, where the impact is transmitted into the bearing floor predominantly through the area directly excited by the hammers of the tapping machine

Note 1 to entry: Thus the improvement of impact sound insulation does not depend on the size of the specimen.

## 4 Principle

The method in this part of ISO 16251 is directly based on the ISO 10140<sup>[4]</sup> series, where the test setup consists of two rooms above each other, separated by a standard concrete floor, on which the flooring to be tested is applied. In this part of ISO 16251, the two rooms are removed and the concrete floor is replaced by a small concrete plate of similar thickness (see [Annex A](#)). This plate is structurally decoupled from the surroundings by elastic suspensions. As in the ISO 10140<sup>[4]</sup> series, a standard tapping machine is used as an impact source and two sound levels “in the lower room” are determined, once with and once without the specimen on the plate. However, instead of the sound pressure level in the lower room, the structure-borne sound level at the lower surface of the concrete plate is determined. It is assumed that for locally reacting floor coverings the structure-borne sound level difference equals the impact sound reduction according to the ISO 10140<sup>[4]</sup> series.

In this part of ISO 16251, structure-borne sound levels are expressed in terms of acceleration levels. Nevertheless, the same procedures can be applied when measuring velocity or displacement levels instead.

## 5 Equipment

### 5.1 Test setup

The setup is shown in [Annex A](#). It consists of a concrete slab, which is softly supported at its four corners. The area of each elastic support shall not exceed  $10 \text{ cm} \times 10 \text{ cm}$ . The vertical resonance of the concrete slab on the elastic bearings shall lie below 20 Hz.

The size of the slab shall be  $(120 \pm 5) \text{ cm} \times (80 \pm 5) \text{ cm} \times (20 \pm 1) \text{ cm}$ . It shall be homogeneous and of uniform thickness. Ensure that the surface of the slab is flat to  $\pm 1 \text{ mm}$  in a horizontal line from edge to edge, and sufficiently hard to endure the impacts of the tapping machine. A screed is allowed to provide sufficient flatness.

## 5.2 Instruments

The vibratory acceleration is measured by one or more accelerometers. The signals generated by the accelerometers shall be amplified, filtered in third-octave bands, and indicated as r.m.s. values. The structure-borne noise shall be measured with a sound level meter or an equivalent measurement system which has been declared to be in compliance with the requirements of at least IEC 61672-1<sup>[8]</sup>, class 1 with the microphone replaced by the accelerometer. Verify that the filters have been declared to be in accordance with IEC 61260<sup>[7]</sup>, class 1.

Ensure that the tapping machine used has been declared to meet the requirements specified in ISO 10140-5<sup>[6]</sup>.

The vibration calibration shall comply with the requirements of ISO 16063 (all parts).

As the acceleration signals at least on the bare concrete plate consist of extremely short pulses, some measurement chains may produce rather obviously erroneous results, although meeting all specifications mentioned in the preceding for accelerometers, sound level meters, and filters. Before using a measurement chain for the first time, ensure that the chain is functioning correctly, e.g. by a comparison with measurements according to ISO 10140<sup>[4]</sup>.

## 6 Test procedure

### 6.1 Installing the specimens

The test specimens shall be big enough to place the whole tapping machine on it, but not larger than the upper surface of the concrete slab. The manufacturer's installation instructions shall be applied, paying attention especially to the edges of the specimens to avoid lifting. If floor coverings require an adhesive and/or a primer, it is necessary to meet a drying time to achieve the products hardening.

### 6.2 Placement of tapping machine and accelerometers

The accelerometer(s) shall be rigidly attached to the lower surface of the concrete slab (screwed or glued). Incorrect measurements may be caused by poor fixing and cable routing or by environmental conditions such as strong electric or magnetic fields, temperature or temperature transients. For details, see ISO 5348<sup>[3]</sup> and the recommendations of the manufacturer of the equipment.

At least four accelerometer positions shall be used. They shall be uniformly, but randomly, distributed over the lower surface of the slab, avoiding symmetric lines and keeping away at least 10 cm from the edges of the slab.

The tapping machine shall be used in at least two positions, avoiding symmetry and parallelism to the edges of the plate and with a minimum distance of 30 cm from each other. No hammer shall be closer to the edges of the plate than 10 cm. After placement, all feet of the tapping machine shall stand on the specimen.

### 6.3 Frequency range

The acceleration level shall be measured using one-third-octave band filters with the following centre frequencies, in hertz:

100	125	160	200	250	315
400	500	630	800	1 000	1 250
1 600	2 000	2 500	3 150	4 000	5 000

If additional information in the low-frequency range is required, use one-third-octave band filters with the following centre frequencies, in hertz:

50

63

80

## 6.4 Measurement

Air temperature and humidity in the measurement room shall be recorded before and after the measurement. The vibro-acoustic measurement system shall be calibrated before and rechecked after the measurement.

Three measurement cycles shall be carried out.

- Measurement with specimen on the plate. Place the tapping machine at its first position and record the acceleration level spectrum at each receiver point. Repeat the procedure for the next tapping machine position(s), keeping the same accelerometer positions as before. The measured levels are denoted as  $L'_{1,t,a}$ : index  $s = 1$  for the specimen in place,  $t = 1, 2, \dots$  for the tapping machine position and  $a = 1, 2, 3, 4, \dots$  for the accelerometer position. The quotation mark ' indicates the inclusion of background noise.
- Measurement without specimen. Take the same tapping machine and accelerometer positions as in a) and proceed as in a). Hammer positions with and without floor covering shall coincide within  $\pm 2$  cm. These measured background infected levels are denoted as  $L'_{0,t,a}$  with index  $s = 0$  for the absent specimen.
- Measurement of background noise. Switch the tapping machine off and record the acceleration level spectrum at each receiver point. The measured levels are denoted as  $L_{b,a}$ , "b" for background and  $a = 1, 2, 3, 4 \dots$  for the accelerometer positions.

The averaging time for all level measurements shall be not less than 20 s. If more than one sample of the same flooring shall be tested, repeat a) and c) and keep the results for each specimen separate.

## 6.5 Evaluation of results

At first, all measured levels shall be corrected for the background noise of the corresponding accelerometer position. If  $L'_{s,t,a}$  denotes the measured level before correction and  $L_{s,t,a}$  after correction, then the background corrected levels result from:

$$L_{s,t,a} = \begin{cases} L'_{s,t,a} & \text{if } L'_{s,t,a} - L_{b,a} \geq 15 \text{ dB} \\ 10 \cdot \lg \left[ 10^{L'_{s,t,a}/10} - 10^{L_{b,a}/10} \right] \text{ dB} & \text{if } 6 \text{ dB} \leq L'_{s,t,a} - L_{b,a} < 15 \text{ dB} \\ L'_{s,t,a} - 1,3 \text{ dB} & \text{if } L'_{s,t,a} - L_{b,a} < 6 \text{ dB} \end{cases} \quad (2)$$

Then, for each accelerometer position  $a$  and tapping machine position  $t$  the level difference of corrected levels without and with specimen shall be evaluated according to

$$\Delta L_{t,a} = L_{0,t,a} - L_{1,t,a} \quad (3)$$

Finally, the impact sound improvement of the specimen results from

$$\Delta L = \frac{1}{t \cdot a} \sum_t \sum_a \Delta L_{t,a} \text{ dB} \quad (4)$$

where  $t$  runs from 1 to the total number of tapping machine positions and  $a$  from 1 to the total number of accelerometer positions.

Calculate the weighted impact sound improvement  $\Delta L_w$  from Formula (4) according to ISO 717-2. If more than one specimen was tested, the impact sound improvement values of the specimens from Formula (4) shall be arithmetically averaged before applying ISO 717-2.

## 7 Uncertainty

For locally reacting floor coverings, there is no systematic shift between results from ISO 10140<sup>[4]</sup> and this part of ISO 16251.

## 8 Expression of results

The results shall be presented in a table, showing

- the third-octave band values of the “bare floor” vibratory acceleration level  $L_{a,0}$  (with indication of reference acceleration  $a_0$ );
- the third-octave band values of the impact sound improvement  $\Delta L$  of each sample tested;
- (if more than one sample) the third-octave band values of the average impact sound improvement;
- the corresponding weighted impact sound improvement(s);
- spectrum adaption term(s)  $C_{I,\Delta}$ .

All values shall be rounded to one decimal place. Wherever the background correction reached 1,3 dB, the corresponding improvement value  $\Delta L$  shall be stated as “> $\Delta L$ ”, indicating its limitation by background noise.

The impact sound improvement  $\Delta L$  of the sample (or the average in case of more than one sample) shall also be plotted as a graph with the following axes scaling:

- 5 mm for each third octave band;
- 20 mm for each 10 dB.

The use of a form in accordance with [Table B.1](#) is preferred. Being a short version of the test report, it shall state all information of importance regarding the test object, the test procedure, and the test results.

If the reduction of impact sound pressure level is also needed in octave bands, these values shall be calculated from the three one-third-octave band values in each octave band using Formula (5).

$$\Delta L_{\text{Oct}} = -10 \lg \left( \frac{\sum_{n=1}^3 10^{-\Delta L_{1/3 \text{ oct}, n} / 10}}{3} \right) \text{ dB} \quad (5)$$

## 9 Test report

The test report shall include at least the following information.

- reference to this part of ISO 16251 (i.e. ISO 16251-1:2014);
- name and address of the testing laboratory;
- manufacturer’s name and product identification;
- name and address of the organization or person who ordered the test (client);
- date of test;

- f) detailed description of the floor covering under test, number and size of the test specimen(s);
- g) method of mounting, in particular adhesive, its mass per area and curing time, if applied;
- h) temperature and humidity of the environment during test;
- i) positions of the tapping machine and accelerometers;
- j) a statement as to whether the test specimen suffered visible damage during the test (e.g. compaction);
- k) all quantities as specified in [Clause 8](#);
- l) brief description of procedure and equipment.

## Annex A (normative)

### Test setup

The test setup consists of a concrete slab and four elastic supports at the corners to decouple the slab dynamically from the underground. None of the four supporting areas shall exceed 10 cm × 10 cm, see [Figures A.1](#) and [A.2](#).

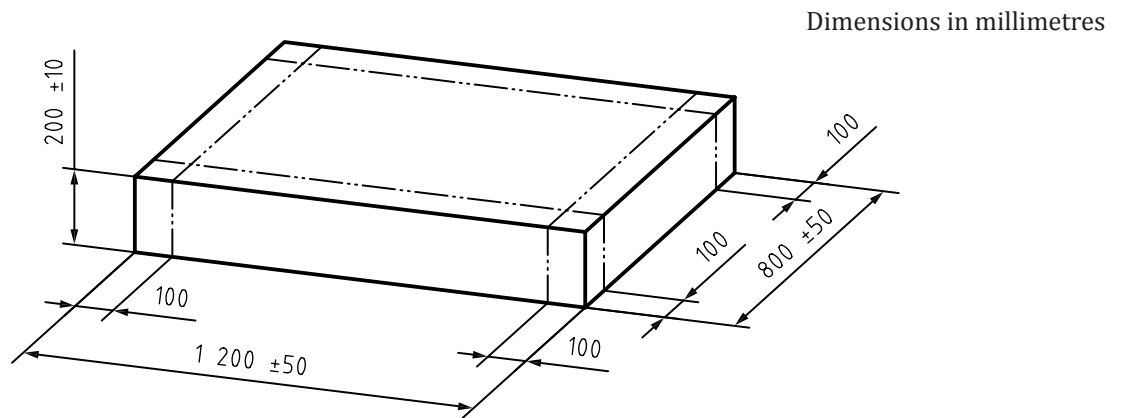
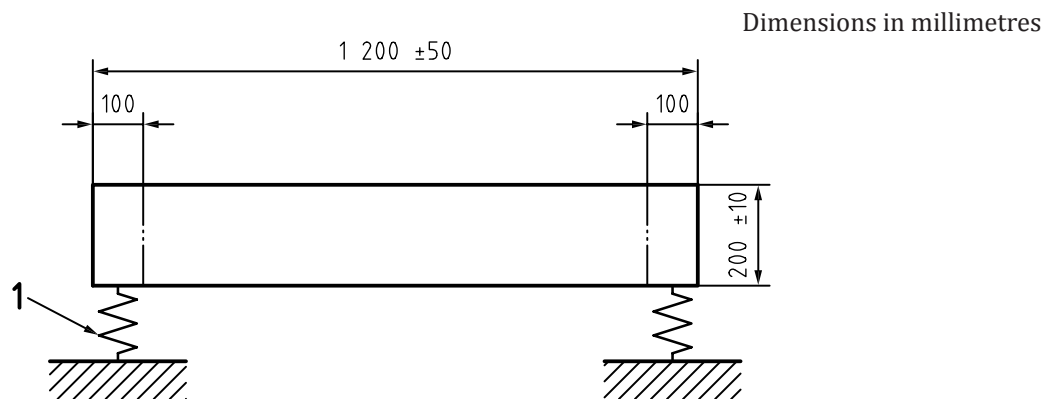

Figure A.1 — Concrete slab



**Key**

1 elastic support

Figure A.2 — Elastic support

**Annex B**  
(informative)

**Design of presentation of results**



**Table B.1 — Example of the form for expression of results**

<b>Reduction of impact sound pressure level according to ISO 16251-1</b>			
Laboratory measurements of the reduction of transmitted impact sound by floor coverings on a heavyweight compact floor			
Manufacturer:		Product identification:	
Client:			
Test specimen mounted by:		Date of test:	
Description of test facility, test specimen and test arrangement:			
Type of reference floor: heavyweight compact			
Mass of test specimen per unit area:		kg/m <sup>2</sup>	
Curing time of specimen:		h	
Air temperature:		°C	
Air humidity:		%	
	<b>Frequency</b> <i>f</i> Hz	<i>L</i> <sub>a,0</sub> <sup>a</sup> one-third octave dB	$\Delta L$ one-third octave dB
	50 63 80		
	100 125 160		
	200 250 315		
	400 500 630		
	800 1 000 1 250		
	1 600 2 000 2 500		
	3 150 4 000 5 000		
<sup>a</sup> <i>a</i> <sub>0</sub> = .....m/s <sup>2</sup>			
Rating according to ISO 717-2: $\Delta L_w =$ ( ) dB; $C_{l,\Delta} =$ dB; $C_{l,r} =$ dB; $C_{l,r,50-2500} =$ dB These results are based on a test made with an artificial source under laboratory conditions (engineering method) with the specified reference floor of reduced size.			
No. of test report:		Name of test institute:	
Date:		Signature:	

## Bibliography

- [1] ISO 266, *Acoustics — Preferred frequencies*
- [2] ISO 5347 (all parts), *Methods for the calibration of vibration and shock pick-ups*
- [3] ISO 5348, *Mechanical vibration and shock — Mechanical mounting of accelerometers*
- [4] ISO 10140 (all parts), *Acoustics — Laboratory measurement of sound insulation of building elements*
- [5] ISO 10140-1:2010, *Acoustics — Laboratory measurement of sound insulation of building elements — Part 1: Application rules for specific products*
- [6] ISO 10140-5, *Acoustics — Laboratory measurement of sound insulation of building elements — Part 5: Requirements for test facilities and equipment*
- [7] IEC 61260, *Electroacoustics — Octave-band and fractional-octave-band filters*
- [8] IEC 61672-1, *Electroacoustics — Sound level meters — Part 1: Specifications*
- [9] ISO 12999-1, *Acoustics — Determination and application of measurement uncertainties in building acoustics — Part 1: Sound insulation*
- [10] SOMMERFELD M A simplified measurement method for the determination of impact sound reduction. Proceedings of DAGA, Rotterdam, 2009
- [11] FORET R., GUIGOU , CARTER C., CHÉNÉ J.-B A comparison of the reduction of transmitted impact noise by floor coverings using ISO 140-8 and ISO/CD 16251-1. Proceedings of Forum Acusticum Aalborg, 2011
- [12] SCHMIDT J.H., WITTSTOCK V., FORET R., FICHTEL C., SCHECK J. Measuring the impact sound reduction at a compact measurement setup — Design, results and uncertainties. *Journal for Building Acoustics*. 2013, **20** (2) pp. 107–140







# British Standards Institution (BSI)

BSI is the national body responsible for preparing British Standards and other standards-related publications, information and services.

BSI is incorporated by Royal Charter. British Standards and other standardization products are published by BSI Standards Limited.

## About us

We bring together business, industry, government, consumers, innovators and others to shape their combined experience and expertise into standards-based solutions.

The knowledge embodied in our standards has been carefully assembled in a dependable format and refined through our open consultation process. Organizations of all sizes and across all sectors choose standards to help them achieve their goals.

## Information on standards

We can provide you with the knowledge that your organization needs to succeed. Find out more about British Standards by visiting our website at [bsigroup.com/standards](http://bsigroup.com/standards) or contacting our Customer Services team or Knowledge Centre.

## Buying standards

You can buy and download PDF versions of BSI publications, including British and adopted European and international standards, through our website at [bsigroup.com/shop](http://bsigroup.com/shop), where hard copies can also be purchased.

If you need international and foreign standards from other Standards Development Organizations, hard copies can be ordered from our Customer Services team.

## Subscriptions

Our range of subscription services are designed to make using standards easier for you. For further information on our subscription products go to [bsigroup.com/subscriptions](http://bsigroup.com/subscriptions).

With **British Standards Online (BSOL)** you'll have instant access to over 55,000 British and adopted European and international standards from your desktop. It's available 24/7 and is refreshed daily so you'll always be up to date.

You can keep in touch with standards developments and receive substantial discounts on the purchase price of standards, both in single copy and subscription format, by becoming a **BSI Subscribing Member**.

**PLUS** is an updating service exclusive to BSI Subscribing Members. You will automatically receive the latest hard copy of your standards when they're revised or replaced.

To find out more about becoming a BSI Subscribing Member and the benefits of membership, please visit [bsigroup.com/shop](http://bsigroup.com/shop).

With a **Multi-User Network Licence (MUNL)** you are able to host standards publications on your intranet. Licences can cover as few or as many users as you wish. With updates supplied as soon as they're available, you can be sure your documentation is current. For further information, email [bsmusales@bsigroup.com](mailto:bsmusales@bsigroup.com).

## BSI Group Headquarters

389 Chiswick High Road London W4 4AL UK

## Revisions

Our British Standards and other publications are updated by amendment or revision.

We continually improve the quality of our products and services to benefit your business. If you find an inaccuracy or ambiguity within a British Standard or other BSI publication please inform the Knowledge Centre.

## Copyright

All the data, software and documentation set out in all British Standards and other BSI publications are the property of and copyrighted by BSI, or some person or entity that owns copyright in the information used (such as the international standardization bodies) and has formally licensed such information to BSI for commercial publication and use. Except as permitted under the Copyright, Designs and Patents Act 1988 no extract may be reproduced, stored in a retrieval system or transmitted in any form or by any means – electronic, photocopying, recording or otherwise – without prior written permission from BSI. Details and advice can be obtained from the Copyright & Licensing Department.

## Useful Contacts:

### Customer Services

**Tel:** +44 845 086 9001

**Email (orders):** [orders@bsigroup.com](mailto:orders@bsigroup.com)

**Email (enquiries):** [cservices@bsigroup.com](mailto:cservices@bsigroup.com)

### Subscriptions

**Tel:** +44 845 086 9001

**Email:** [subscriptions@bsigroup.com](mailto:subscriptions@bsigroup.com)

### Knowledge Centre

**Tel:** +44 20 8996 7004

**Email:** [knowledgecentre@bsigroup.com](mailto:knowledgecentre@bsigroup.com)

### Copyright & Licensing

**Tel:** +44 20 8996 7070

**Email:** [copyright@bsigroup.com](mailto:copyright@bsigroup.com)



...making excellence a habit.™