

BS EN ISO 16119-2:2013



BSI Standards Publication

Agricultural and forestry machinery - Environmental requirements for sprayers

Part 2: Horizontal boom sprayers
(ISO 16119-2:2013)

bsi.

...making excellence a habit.™

National foreword

This British Standard is the UK implementation of EN ISO 16119-2:2013. It is identical to ISO 16119-2:2013. It supersedes BS EN 12761-2:2001 which is withdrawn.

The UK participation in its preparation was entrusted to Technical Committee AGE/15, Equipment for crop protection and application of liquid fertilizer.

A list of organizations represented on this committee can be obtained on request to its secretary.

This publication does not purport to include all the necessary provisions of a contract. Users are responsible for its correct application.

© The British Standards Institution 2013.
Published by BSI Standards Limited 2013

ISBN 978 0 580 72833 4

ICS 65.060.40

Compliance with a British Standard cannot confer immunity from legal obligations.

This British Standard was published under the authority of the Standards Policy and Strategy Committee on 31 March 2013.

Amendments issued since publication

Date	Text affected
------	---------------

English Version

**Agricultural and forestry machinery - Environmental
requirements for sprayers - Part 2: Horizontal boom sprayers
(ISO 16119-2:2013)**

Matériel agricole et forestier - Exigences
environnementales pour les pulvérisateurs - Partie 2:
Pulvérisateurs à rampe horizontale (ISO 16119-2:2013)

Land- und Forstmaschinen - Pflanzenschutzgeräte zum
Ausbringen von Pflanzenschutzmitteln und flüssigen
Düngemitteln - Umweltschutz - Teil 2: Feldspritzgeräte und
vergleichbare Geräte (ISO 16119-2:2013)

This European Standard was approved by CEN on 5 January 2013.

CEN members are bound to comply with the CEN/CENELEC Internal Regulations which stipulate the conditions for giving this European Standard the status of a national standard without any alteration. Up-to-date lists and bibliographical references concerning such national standards may be obtained on application to the CEN-CENELEC Management Centre or to any CEN member.

This European Standard exists in three official versions (English, French, German). A version in any other language made by translation under the responsibility of a CEN member into its own language and notified to the CEN-CENELEC Management Centre has the same status as the official versions.

CEN members are the national standards bodies of Austria, Belgium, Bulgaria, Croatia, Cyprus, Czech Republic, Denmark, Estonia, Finland, Former Yugoslav Republic of Macedonia, France, Germany, Greece, Hungary, Iceland, Ireland, Italy, Latvia, Lithuania, Luxembourg, Malta, Netherlands, Norway, Poland, Portugal, Romania, Slovakia, Slovenia, Spain, Sweden, Switzerland, Turkey and United Kingdom.



EUROPEAN COMMITTEE FOR STANDARDIZATION
COMITÉ EUROPÉEN DE NORMALISATION
EUROPÄISCHES KOMITEE FÜR NORMUNG

Management Centre: Avenue Marnix 17, B-1000 Brussels

Foreword

This document (EN ISO 16119-2:2013) has been prepared by Technical Committee CEN/TC 144 "Tractors and machinery for agriculture and forestry", the secretariat of which is held by AFNOR, in collaboration with Technical Committee ISO/TC 23 "Tractors and machinery for agriculture and forestry".

This European Standard shall be given the status of a national standard, either by publication of an identical text or by endorsement, at the latest by September 2013, and conflicting national standards shall be withdrawn at the latest by September 2013.

Attention is drawn to the possibility that some of the elements of this document may be the subject of patent rights. CEN [and/or CENELEC] shall not be held responsible for identifying any or all such patent rights.

This document supersedes EN 12761-2:2001.

The following major changes were introduced:

- extension of the scope;
- updating of the normative references;
- addition of a Clause "List of significant hazards";
- revision of requirements on control of spray drift and on cleaning;
- addition of a Clause "Verification";
- completion of Clause "Instruction handbook";
- deletion of Annex A "Test method for cleaning plant protection product cans", and deletion of Annex B "Example of device for cleaning of plant protection product cans" and addition of a reference to ISO 21278-1;
- inclusion of Annex C "Additional requirements for band sprayers" into the main text of the Standard;
- addition of Annex ZA.

This document has been prepared under a mandate given to CEN by the European Commission and the European Free Trade Association, and supports essential requirements of EU Directive.

For relationship with EU Directive, see informative Annex ZA, which is an integral part of this document.

According to the CEN-CENELEC Internal Regulations, the national standards organizations of the following countries are bound to implement this European Standard: Austria, Belgium, Bulgaria, Croatia, Cyprus, Czech Republic, Denmark, Estonia, Finland, Former Yugoslav Republic of Macedonia, France, Germany, Greece, Hungary, Iceland, Ireland, Italy, Latvia, Lithuania, Luxembourg, Malta, Netherlands, Norway, Poland, Portugal, Romania, Slovakia, Slovenia, Spain, Sweden, Switzerland, Turkey and the United Kingdom.

Annex ZA (informative)

Relationship between this European Standard and the Essential Requirements of EC Directive 2009/127/EC amending 2006/42/EC

This European Standard has been prepared under a mandate given to CEN by the European Commission and the European Free Trade Association to provide a means of conforming to Essential Requirements of the New Approach Directive 2009/127/EC amending 2006/42/EC.

Once this standard is cited in the Official Journal of the European Union under that Directive and has been implemented as a national standard in at least one Member State, compliance with the normative clauses of this standard confers, within the limits of the scope of this standard, a presumption of conformity with the relevant Essential Requirements of that Directive and associated EFTA regulations.

WARNING — Other requirements and other EU Directives may be applicable to the product(s) falling within the scope of this standard.

Contents

	Page
Foreword	iv
Introduction	v
1 Scope	1
2 Normative references	1
3 Terms and definitions	2
4 List of significant hazards	2
5 Requirements	3
5.1 General.....	3
5.2 Volume/hectare adjustment system.....	9
5.3 Distribution and control of spray drift.....	9
5.4 Cleaning.....	10
5.5 Cleaning devices.....	11
5.6 Additional requirements for band sprayers.....	11
5.7 Additional requirements for spray guns and lances.....	12
6 Verification	12
7 Marking	13
8 Instruction handbook	13
Bibliography	14

Foreword

ISO (the International Organization for Standardization) is a worldwide federation of national standards bodies (ISO member bodies). The work of preparing International Standards is normally carried out through ISO technical committees. Each member body interested in a subject for which a technical committee has been established has the right to be represented on that committee. International organizations, governmental and non-governmental, in liaison with ISO, also take part in the work. ISO collaborates closely with the International Electrotechnical Commission (IEC) on all matters of electrotechnical standardization.

International Standards are drafted in accordance with the rules given in the ISO/IEC Directives, Part 2.

The main task of technical committees is to prepare International Standards. Draft International Standards adopted by the technical committees are circulated to the member bodies for voting. Publication as an International Standard requires approval by at least 75 % of the member bodies casting a vote.

Attention is drawn to the possibility that some of the elements of this document may be the subject of patent rights. ISO shall not be held responsible for identifying any or all such patent rights.

ISO 16119-2 was prepared by the European Committee for Standardization (CEN) Technical Committee CEN/TC 144, *Tractors and machinery for agriculture and forestry*, in collaboration with ISO Technical Committee TC 23, *Tractors and machinery for agriculture and forestry*, Subcommittee SC 6, *Equipment for crop protection*, in accordance with the Agreement on technical cooperation between ISO and CEN (Vienna Agreement).

ISO 16119 consists of the following parts, under the general title *Agricultural and forestry machinery — Environmental requirements for sprayers*:

- *Part 1: General*
- *Part 2: Horizontal boom sprayers*
- *Part 3: Sprayers for bush and tree crops*
- *Part 4: Fixed and semi-mobile sprayers*

Introduction

The requirements of this part of ISO 16119 are based on the test methods given in ISO 5682-2:1997, which were primarily developed for hydraulic sprayers. For other types of sprayers, other test methods and/or test criteria may be needed and may be the subject of future investigation and a revision of this part of ISO 16119.

This document is a type C standard as stated in ISO 12100.

The machinery concerned and the extent to which hazards, hazardous situations and hazardous events are covered are indicated in the scope of this document.

When provisions of this type C standard are different from those which are stated in type A or B standards, the provisions of this type C standard take precedence over the provisions of the other standards, for machines that have been designed and built according to the provisions of this type C standard.

Agricultural and forestry machinery — Environmental requirements for sprayers —

Part 2: Horizontal boom sprayers

1 Scope

This part of ISO 16119 specifies requirements and the means for their verification for the design and performance of horizontal boom sprayers, as defined in 3.1, with regard to minimizing the potential risk of environmental contamination during use, including misuse foreseeable by the manufacturer.

It is intended to be used with ISO 16119-1, which gives general requirements common to all the sprayer types covered by ISO 16119. When requirements of this part of ISO 16119 are different from those which are stated in ISO 16119-1, the requirements of this part of ISO 16119 take precedence over the requirements of ISO 16119-1 for machines within the scope of this part of ISO 16119. It does not cover safety aspects (see ISO 4254-6).

This part of ISO 16119 is not applicable to sprayers manufactured before the date of its publication.

2 Normative references

The following documents, in whole or in part, are normatively referenced in this document and are indispensable for its application. For dated references, only the edition cited applies. For undated references, the latest edition of the referenced document (including any amendments) applies.

ISO 4102, *Equipment for crop protection — Sprayers — Connection threading*

ISO 4254-6:2009, *Agricultural machinery — Safety — Part 6: Sprayers and liquid fertilizer distributors*

ISO 4288, *Geometrical Product Specifications (GPS) — Surface texture: Profile method — Rules and procedures for the assessment of surface texture*

ISO 5681, *Equipment for crop protection — Vocabulary*

ISO 5682-1, *Equipment for crop protection — Spraying equipment — Part 1: Test methods for sprayer nozzles*

ISO 5682-2:1997, *Equipment for crop protection — Spraying equipment — Part 2: Test methods for hydraulic sprayers*

ISO 5682-3:1996, *Equipment for crop protection — Spraying equipment — Part 3: Test method for volume/hectare adjustment systems of agricultural hydraulic pressure sprayers*

ISO 9357, *Equipment for crop protection — Agricultural sprayers — Tank nominal volume and filling hole diameter*

ISO 13440:1996, *Equipment for crop protection — Agricultural sprayers — Determination of the volume of total residual*

ISO 16119-1:2013, *Agricultural and forestry machinery — Environmental requirements for sprayers — Part 1: General*

ISO 21278-1, *Equipment for crop protection — Induction hoppers — Part 1: Test methods*

ISO 21278-2, *Equipment for crop protection — Induction hoppers — Part 2: General requirements and performance limits*

ISO 22368-1, *Crop protection equipment — Test methods for the evaluation of cleaning systems — Part 1: Internal cleaning of complete sprayers*

ISO 22368-3, *Crop protection equipment — Test methods for the evaluation of cleaning systems — Part 3: Internal cleaning of tank*

ISO 22369-2:2010, *Crop protection equipment — Drift classification of spraying equipment — Part 2: Classification of field crop sprayers by field measurements*

ISO 22856, *Equipment for crop protection — Methods for the laboratory measurement of spray drift — Wind tunnels*

ISO 22866, *Equipment for crop protection — Methods for field measurement of spray drift*

3 Terms and definitions

For the purposes of this document, the terms and definitions given in ISO 5681 and the following apply.

3.1 horizontal boom sprayer

machine for spraying plant protection products, along a boom or in bands, with a spray generally directed downwards onto/into the target

3.2 plant protection product container

collective name for plant protection product packaging

EXAMPLE Can, bottle, bag, sack, box.

3.3 cleaning device

device for cleaning the insides of empty plant protection product containers

Note 1 to entry: The device may be an integral part of the sprayer or an independent installation (e.g. stationary equipment).

4 List of significant hazards

[Table 1](#) specifies the significant hazards, the significant hazardous situations and significant hazardous event(s) covered by this part of ISO 16119 that have been identified by risk assessment as being relevant for this type of machine with regard to environmental contamination, and which require specific action by the designer or manufacturer to eliminate or to reduce environmental contamination.

Attention is drawn to the necessity to verify that the environmental requirements specified in both ISO 16119-1 and this part of ISO 16119 apply to each significant hazard presented by a given machine and to validate that the risk assessment is complete.

Table 1 — List of significant hazards

Hazard		Hazardous situation/ event	Clause/subclause of this part of ISO 16119
4.1	Spillages	Filling	5.1.1.2; 8
		Induction of plant protection product	5.1.1.2; 8
4.2	Contamination of the water supply	Filling	5.1.1.2
4.3	Leakages	Transport and application	5.1.1.2; 5.1.2
		Contact with obstacles	5.1.3.3; 5.1.5
4.4	Overfilling	Filling	5.1.1.2; 5.1.1.4; 8
4.5	Dispersal of spray mixture residues or plant protection products	Drainage	5.1.1.3.1; 5.1.1.4; 8
		Cleaning and rinsing	5.1.1.1; 5.4; 5.5; 8
4.6	Accidental leakages	Accidental opening of tank outlet	5.1.1.3.2
4.7	Over-dosing	Heterogeneous mixing	5.1.1.5; 8
		Overlapping	5.1.3.1
		Sprayer adjustment/control	5.1.1.4; 5.1.2; 5.1.6; 5.2; 5.7; 8
		Sprayer maintenance/service	5.1.7; 7; 8
4.8	Unintended spraying outside the target area	Unintended deposition	5.3.1; 5.1.3.2; 5.6.3
		Deposition outside the target area	5.1.3.1; 5.6.1; 5.6.2
4.9	Drift	Spraying stop control	5.1.2; 5.7
		Spraying	5.1.3.2; 5.3.2; 7; 8
4.10	Dispersal of spray mixture	Intervention on the sprayer during application or service	5.1.4; 7; 8
4.11	Dripping	Spraying stop control	5.1.5

5 Requirements

5.1 General

5.1.1 Spray tank

5.1.1.1 Surfaces

The depth of roughness, R_z , (see ISO 4287) of the inner and outer walls of the tank shall be such that $R_z \leq 100 \mu\text{m}$, measured according to ISO 4288.

5.1.1.2 Filling

Filling devices shall be designed to avoid any return of liquid from the tank to the filling supply.

The filling hole diameter shall comply with ISO 9357. The opening lid shall seal sufficiently to prevent leakage/spillage when closed.

The total tank volume shall be at least 5 % more than its nominal volume, to prevent spillage as a result of overfilling. Tanks with a nominal volume greater than 200 l shall have a nominal volume which is a multiple of 100 l.

Strainers shall have a minimum depth, d , as given in [Table 2](#) and measured according to [Figure 1](#).

Strainers shall be installed in filling openings and shall have a mesh size less than 2 mm. Any gaps between the tank filling hole and the strainer shall not exceed 2 mm (see [Figure 1](#)).

The filling capacity of the tank with strainer when filled with water shall be at least 100 l/min for tanks with a nominal volume of 100 l or more. For tanks with a nominal volume of less than 100 l, it shall be possible to fill the tank within 1 min.

Induction hoppers shall comply with ISO 21278-2.

Table 2 — Minimum depth of strainers

Nominal tank capacity	Minimum depth ^a
C	d
l	mm
$C \leq 150$	60
$150 < C \leq 400$	100
$400 < C \leq 600$	150
$C > 600$	250
^a Measured from the upper edge of the strainer down to its bottom.	

Dimensions in millimetres

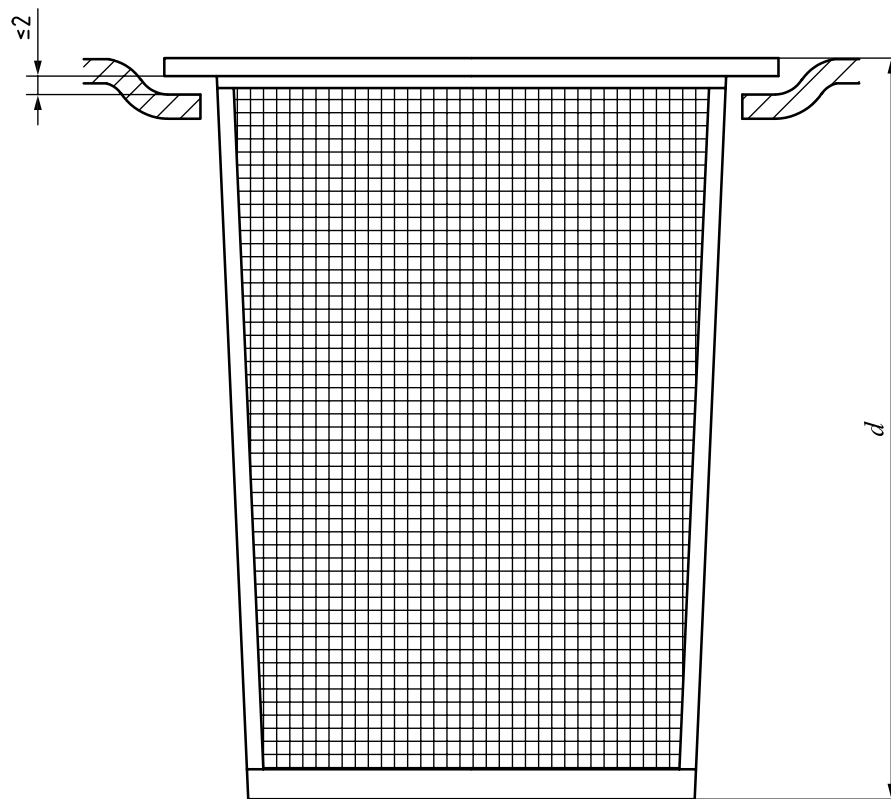

Key

d minimum depth

Figure 1 — Determination of the depth of the strainer and width of gap(s)

5.1.1.3 Emptying

5.1.1.3.1 Residual volume

The volume of total residual as defined in ISO 13440:1996, 2.1 shall not exceed 0,5 % of the nominal tank volume plus 2 l/m of the boom.

The volume of total residual shall be determined in accordance with ISO 13440.

5.1.1.3.2 Tank emptying device

An emptying device in accordance with ISO 4254-6:2009, 5.4.3 shall allow the complete emptying of the residual in the tank when the sprayer is in a horizontal position. Complete emptying of the residual is considered to have been achieved when there are no visible puddles at the bottom of the tank after 5 min drainage.

It shall be possible to collect the liquid at the outlet without contaminating the environment or equipment parts, e.g. stays.

The tank outlet shall be guarded against accidental opening.

5.1.1.4 Tank contents indicator(s)

The indication of contents shall correspond to ISO 9357. It shall be durable and easily readable from the driver's position and from where the tank is filled. Turning of the head and the upper body is acceptable.

The acceptable tolerances of the indication are

- $\pm 15\%$ for each graduation mark/read-out value for volumes up to 10 % of the nominal tank volume,
- $\pm 7,5\%$ for each graduation mark/read-out value for volumes from 10 % to 20 % of the nominal tank volume, and
- $\pm 5\%$ for each graduation mark/read-out value for volumes above 20 % of the nominal tank volume.

The tolerances shall be measured with a maximum error on measurement of $\pm 1\%$ with the sprayer in a horizontal position.

5.1.1.5 Mixing

Tanks shall be designed (e.g. including agitators) to ensure an even concentration of mixture. The maximum allowable deviation is $\pm 15\%$, tested in accordance with ISO 5682-2.

5.1.2 Lines (hoses and pipes)

The bending radius of hoses shall be within the limits recommended by the hose manufacturer. Hoses shall not have any deformation which could disturb the liquid flow.

Pressure lines shall be equipped with quick-acting shut-off devices (e.g. tip-over lever valves).

The maximum working pressure of hoses and the maximum working pressure of connecting devices shall be at least equal to the maximum working pressure of the circuit. See also ISO 16119-1:—, Clause 6 h).

5.1.3 Spray boom

5.1.3.1 Spraying section widths

The maximum spraying section widths shall be

- 4,5 m for boom widths less than 24 m, and
- 6,0 m for boom widths greater than or equal to 24 m.

It shall be possible to switch on and off any individual boom section on its own or in combination.

5.1.3.2 Adjustment

The adjustment range for the spray boom height shall be at least 1,0 m.

It shall be possible to adjust the minimum distance between the nozzles and the target according to the nozzle characteristics. For sprayers that are to be used in crops higher than 1,0 m, the adjustment range of the boom height shall be at least 1,2 m.

It shall be possible to adjust the distance between the nozzles and ground down to 0,5 m, except when the machine is designed for special applications (e.g. corn spraying against diabrotica).

The boom height shall be adjustable, either continuously or by increments not exceeding 0,1 m.

Regardless of the distance of the boom above the ground and the nozzles fitted (as recommended by the manufacturer), no liquid shall be sprayed onto the sprayer itself. This does not apply to components of the sprayers (e.g. sensors) that in order to function are necessarily in contact with the mixture; for these, however, dripping shall be minimized.

For spray booms with a working width of more than 13 m, boom movements independent of the sprayer (e.g. passive or active levelling devices) shall ensure that the boom can be positioned parallel to the ground.

5.1.3.3 Contact with obstacles

Folding spray booms with a working width up to 10 m shall be able to move backwards in case of contact with obstacles in the field.

Verification of this requirement shall be by moving the sprayer forwards at a speed of $4 \text{ km/h} \pm 0,2 \text{ km/h}$ with the obstacle placed within 90 % to 100 % of the half working-width of the boom, measured from the middle of the track (see [Figure 2](#)). The spray boom shall be able to give way without being damaged.

Spray booms with a working width of more than 10 m shall be able to move backwards and forwards in case of contact with obstacles in the field.

Verification of this requirement shall be by moving the sprayer forwards at a speed of $4 \text{ km/h} \pm 0,2 \text{ km/h}$ and backwards at $2 \text{ km/h} \pm 0,2 \text{ km/h}$, with the obstacle placed within 90 % to 100 % of half working width of the boom, at a maximum of 1,5 m from the boom end, measured from the middle of the track (see [Figure 2](#)). The spray boom shall be able to give way without being damaged.

Spray booms or boom sections shall return immediately and automatically to their original position after coming into contact with obstacles.

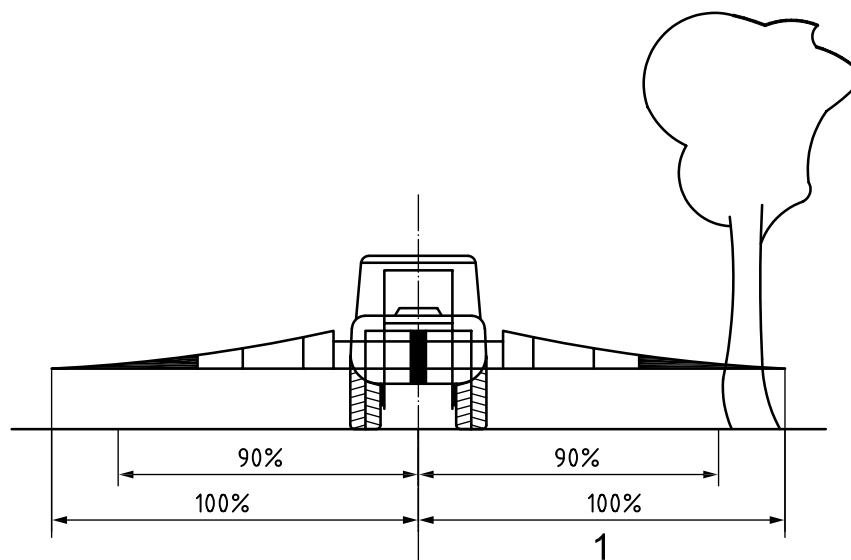

Key

1 half working width

Figure 2 — Contact with obstacles

5.1.4 Filter

Sprayers equipped with a positive displacement pump shall have a suction filter.

On the pressure side, the liquid going to the nozzles shall be filtered by means of central filters or filters in the lines of boom sections. The size of filters shall correspond to the size of nozzles fitted on the sprayer. This applies also to nozzle and pump filters.

The operator shall be able to detect blockages — for example, by an appropriate positioning of the central pressure filters and pressure indicator.

Filters shall be easily accessible and filter inserts shall be removable. For quick cleaning, the filter tissue of the insert shall be easily accessible.

It shall be possible, with the tank filled to its nominal volume, to clean central filters without any spray liquid leaking out except for that which may be present in the filter casing and connected suction or pressure lines.

5.1.5 Nozzles

It shall be possible to fix nozzles in predetermined positions, to ensure that the spray is correctly directed, by appropriate means such as marking, locking systems or mouldings.

When the spraying stop control has been activated, there shall be no dripping. Verification of this requirement is by the following test. When the spraying stop control has been activated, the dripping shall not exceed 2 ml per nozzle during a period of 5 min, starting 8 s after the spraying stop control has been activated.

The nozzles at the end of spray booms of more than 10 m working width shall be protected against damage from contact with the ground.

The flow rate of each individual nozzle, measured according to ISO 5682-1, shall not deviate by more than 5 % from the data of the flow rate tables.

5.1.6 Measuring systems

The working pressure, the volume application rate (in litres per hectare), where relevant, the control setting and the tank volume indication shall be clearly readable from the operator's position. Turning of the head and the upper body is acceptable.

Sprayers shall be fitted with a pressure indicator complying with ISO 4254-6:2009, 5.5, the accuracy of which shall be¹⁾

- $\pm 0,2$ bar for working pressures between 1 bar (included) and 8 bar (included),
- $\pm 0,5$ bar for working pressures between 8 bar and 20 bar (included), and
- ± 1 bar for working pressures more than 20 bar.

The pressure indicator shall be clearly readable. The pressure indication shall be stable. The scale of the pressure indicator shall be marked as follows:

- every 0,2 bar for working pressures less than 5 bar;
- every 1,0 bar for working pressures between 5 bar (included) and 20 bar (included);
- every 2,0 bar for working pressures more than 20 bar.

Unless otherwise specified in this part of ISO 16119, each measuring system of the sprayer, e.g. for flow rate, forward speed, pressure or air speed, except for the tank indicator (see [5.1.1.4](#)), shall be measured within a maximum error of ± 5 % of the true value.

5.1.7 Provisions for connecting test equipment

Means shall be provided to test the pressure indicator

- on the sprayer with a connection having a 1/4 inch or 1/2 inch inner thread according to ISO 4102, or
- it shall be possible to demount the pressure indicator from the sprayer, without need to demount other parts of the sprayer.

Means shall also be provided to connect a flow meter between the pump and the pressure regulator without damaging any hoses or removing the couplers from the hoses.

1) 1 bar = 0,1 MPa = 0,1 N/mm² = 10⁵ N/m².

If the sprayer is equipped with a flow meter, the sprayer shall be equipped with a connecting device allowing the fitting of a test flow meter without the need to dismount the machine flow meter.

5.2 Volume/hectare adjustment system

5.2.1 General

The maximum error for all the measurements specified in 5.2.2 shall be $\pm 2,5$ %.

5.2.2 Measurements

5.2.2.1 Pressure adjustment devices shall maintain a constant working pressure at constant revolutions of the pump. After switching off/on the spray boom and its individual sections during spraying operation, the working pressure shall return to its original value within $\pm 7,5$ %.

5.2.2.2 The following applies to volume/hectare adjustment systems.

- a) 7 s after variations in operating conditions, the measured volume application rate shall be within ± 10 % of the mean volume application rate in the new constant operating condition.

NOTE Changes in operating conditions are effected, for instance, by switching off nozzles, varying the travelling speed or switching off/on sections of the sprayer boom.

- b) During repeated adjustments to the same volume application rate (l/ha), the coefficient of variation calculated from seven measurements shall not exceed 3 %.
- c) While spraying with constant PTO (power take off) rotational speed and at a constant travelling speed, the maximum deviation from the mean volume application rate (l/ha) shall not exceed 5 %.
- d) The acceptable deviation on the measured volume application rate (l/ha) or respective flow rate (l/min) from the values required shall be
- 1) ± 6 % for the mean deviation, and
 - 2) 3 % for the coefficient of variation.

The test of the volume–hectare adjustment system shall be carried out in accordance with ISO 5682-3. Verification of requirement a), above, shall be checked according to ISO 5682-3:1996, 5.1 and 5.2; requirements b), c) and d) shall be checked according to ISO 5682-3:1996, 5.3.

5.2.2.3 The pressure drop between the measuring point for spraying pressure on the horizontal boom sprayer and the nozzle (including anti-drip device, if available) or the orifice plate shall not exceed 10 % of the pressure shown on the pressure indicator. This test shall be performed at maximum flow rate as indicated by the manufacturer in the instruction handbook.

5.2.2.4 Appropriate calibration aids — at least a measuring jar with a capacity of 1 l and an accuracy of $\pm 2,5$ % and with a scale marked every 20 ml — shall be supplied together with the sprayer.

5.3 Distribution and control of spray drift

5.3.1 Distribution

If nozzles are used on a boom to provide a uniform spray, the transverse volume distribution shall be measured on a 100 mm groove patternator (see ISO 5682-2). The coefficient of variation shall not exceed 7 % at one boom height and one pressure specified by the manufacturer. For other boom heights and pressures specified by the manufacturer, the coefficient of variation shall not exceed 9 %. This shall be

measured in accordance with ISO 5682-2 for specified boom heights and pressures only. The coefficient of variation shall be calculated in accordance with ISO 5682-3.

NOTE Other systems for measuring the transverse volume distribution are allowed if the same accuracy is achieved.

For nozzles with overlapping spray patterns, this applies only for those parts of the boom where there is a total overlap.

The flow rate of each nozzle when mounted on the spray boom shall not deviate by more than 10 % from the data given in the flow rate tables provided by the sprayer manufacturer.

The flow rate of each nozzle of the same type and size, when mounted on the spray boom, shall not deviate by more than 5 % from the mean flow rate of all the nozzles on the boom.

Verification of these flow rate requirements shall be by attaining a measuring error of less than $\pm 2,5$ % of the true value.

5.3.2 Control of spray drift

The sprayer shall be designed to reduce drift as far as practicable.

It shall be possible to adjust the horizontal boom sprayer in order not to generate more drift than the equipment specified in ISO 22369-2:2010, Table 2.

Measurement methods are given in ISO 22856, ISO 22866 and ISO 22369-3.

5.4 Cleaning

5.4.1 Water tank

A water tank (or tanks) shall be provided for rinsing the spraying equipment. This tank shall not be combined with the clean water tank for the operator's use (see ISO 4254-6:2009, 5.10). It shall have a volume of at least 10 % of the nominal spray tank volume or at least 10 times the volume of residual which can be diluted (see ISO 13440:1996, 2.2). In the latter case, the volume of residual of tank shall be specified in the instruction handbook.

Water tanks shall be designed so that they can be connected with the equipment in such a way that the rinsing of the pipes is possible even when the spray tank is filled to its nominal volume (see also [Clause 8](#)). In addition, the dilution of the volume of residual in the tank shall be possible.

5.4.2 Cleaning systems

5.4.2.1 General

Sprayers shall be equipped with a connecting device to allow the connection of external cleaning devices.

Sprayers shall be provided with an internal tank cleaning system.

The internal tank cleaning system shall reduce the quantity of plant protection product adhered to the inner surfaces by 80 % when tested in accordance with ISO 22368-3.

5.4.2.2 Residue concentration

One or the other of the following requirements, a) or b), applies:

- a) after completion of the cleaning process, the concentration of the residue shall be reduced by a factor of 400 (or 99,75 %), compared with the concentration before starting the cleaning process, tested in accordance with ISO 22368-1;

- b) after completion of the cleaning process as described in the instruction handbook, the concentration of the liquid drained from the main tank outlet shall have been reduced to 2 % of the original concentration in the tank.

NOTE Upon publication of ISO 16236, this part of ISO 16119 is to be amended to include reference to the test method given in ISO 16236 for the evaluation of the drainable volume.

5.5 Cleaning devices

Cleaning devices for plant protection product containers, when provided, shall be designed so that the volume of residue after cleaning is less than 0,01 % of the nominal container volume. Verification of this requirement shall be by means of the test method given in ISO 21278-1.

Means shall be provided for rinsing the containers with clean water and for transferring and collecting the rinsing water in the spray tank without spillage resulting in environmental contamination.

5.6 Additional requirements for band sprayers

5.6.1 General

When band sprayers are used in combination with other machines (e.g. mechanical weeders, potato planters, potato foliage strippers), the negative influences of dust, plant or soil particles on the chemical being applied shall be prevented in so far as this is practicable.

Band sprayers shall be suited to the conditions of use for which they are intended.

Due to the different specific requirements for treating particular crops, some of the following requirements may not be applicable.

5.6.2 Nozzles

The nozzles which are used to treat a band shall be attached in such a way that they are able to follow the unevenness of the ground at a constant height when treating the ground.

The working height of the nozzles shall be adjustable in a non-stepped way.

It shall be possible to change the position of the nozzles — for example, to adjust the band width. Aids such as markings, locks or mouldings shall be provided to assist correct setting.

It shall be possible to adjust the direction of the spray to the inclination, if needed, of the target (e.g. sides of ridges).

A drawing (on the band sprayer or in the instruction handbook) shall be made available indicating the influence of the height and position (vertical and horizontal angle) of the mounted nozzles on the band width.

It shall be possible to switch off, independently, nozzles treating one band.

5.6.3 Distribution

If nozzles are intended to provide even distribution within a band, the transverse volume distribution per band shall be measured according to ISO 5682-1.

For pressure ranges specified by the sprayer manufacturer in the instruction handbook, the deviation shall not exceed ± 30 % of the mean per band.

At both sides of the band, one groove is excluded to calculate the mean.

For testing purposes, the distance between the nozzles and the patternator shall be such that a band width corresponding to that specified by the sprayer manufacturer in the instruction handbook is achieved.

At either edge of the treated band, the transition from 0 % to 100 % volume rate may take up a maximum lateral distance of 50 mm.

5.7 Additional requirements for spray guns and lances

Spray guns and lances shall be provided with a quick-acting start/stop valve. A locking device to hold the spraying control in the spraying position is not allowed.

If the spray gun or lance flow rate is adjustable, a clear marking indicating the flow rate setting shall be provided.

If the pressure indicator of the sprayer cannot be easily read from the operator's position, then a pressure indicator shall be provided on the spray gun or lance.

6 Verification

Verification of the requirements given in [Clauses 5](#) and [6](#) may be made by means of inspection, calculation, or testing as appropriate. The means of verification is either self-evident or specified for particular requirements in [Clauses 5](#) and [6](#), as summarized in [Table 3](#).

Table 3 — List of safety requirements and/or protective measurements and their verification

Subclause of this part of ISO 16119		Verification			
		Inspection	Measurement	Test	Remark
5.1.1	Spray tank				
5.1.1.1	Surfaces		X		ISO 4288
5.1.1.2	Filling	X	X	X	
5.1.1.3	Emptying	X	X	X	ISO 13440 ISO 9357
5.1.1.4	Mixing		X		ISO 5682-2
5.1.2	Lines		X		
5.1.3	Spray boom				
5.1.3.1	Spraying section widths	X			
5.1.3.2	Adjustment	X	X		
5.1.3.3	Contact with obstacles			X	
5.1.4	Filter	X			
5.1.5	Nozzles	X	X		ISO 5682-1
5.1.6	Measuring systems	X	X		
5.1.7	Provisions for connecting test equipment	X			
5.2	Volume/hectare adjustment system	X	X		ISO 5682-2 ISO 5682-3
5.3	Distribution and control of spray drift				
5.3.1	Distribution			X	
5.3.2	Control of spray drift		X	X	ISO 22856 ISO 22866
5.4	Cleaning				
5.4.1	Water tank		X	X	
5.4.2	Cleaning systems		X	X	
5.5	Cleaning devices			X	ISO 21278-1

Table 3 (continued)

Subclause of this part of ISO 16119		Verification			
		Inspection	Measurement	Test	Remark
5.6	Additional requirements for band sprayers				
5.6.1	General		X		
5.6.2	Nozzles		X		
5.6.3	Distribution			X	ISO 5682-1
5.7	Additional requirements for spray guns and lances		X		

7 Marking

ISO 16119-1:2013, Clause 5, applies.

8 Instruction handbook

ISO 16119-1:2013, Clause 6, applies.

In addition, the instruction handbook shall give the following information:

- the dilutable residual volume;
- procedure for rinsing the boom without diluting the mixture in the tank;
- procedure for diluting the volume of residual in the tank;
- procedure for collecting liquid from central filters without any spray liquid leakage (see [5.1.4](#));
- for band sprayers, the conditions of use for which the sprayer is suitable;
- for band sprayers, a drawing which indicates the influence of the height and position (vertical and horizontal angle) of the mounted nozzles on the band width;
- for band sprayers, the working pressure ranges;
- in clear, tabular form, the flow rate in relation to the marking on the spray gun or lance.

Bibliography

- [1] ISO 4287, *Geometrical Product Specifications (GPS) — Surface texture: Profile method — Terms, definitions and surface texture parameters*
- [2] ISO 16119-3, *Agricultural and forestry machinery — Environmental requirements for sprayers — Part 3: Sprayers for bush and tree crops*
- [3] ISO 16236, *Crop protection equipment — Test method for the determination of drainable volume and its concentration*
- [4] ISO 19732, *Equipment for crop protection — Sprayer filters — Colour coding for identification*
- [5] ISO 22369-3, *Crop protection equipment — Drift classification of spraying equipment — Part 3: Potential spray drift measurement for field crop sprayers by the use of a test bench*

British Standards Institution (BSI)

BSI is the national body responsible for preparing British Standards and other standards-related publications, information and services.

BSI is incorporated by Royal Charter. British Standards and other standardization products are published by BSI Standards Limited.

About us

We bring together business, industry, government, consumers, innovators and others to shape their combined experience and expertise into standards-based solutions.

The knowledge embodied in our standards has been carefully assembled in a dependable format and refined through our open consultation process. Organizations of all sizes and across all sectors choose standards to help them achieve their goals.

Information on standards

We can provide you with the knowledge that your organization needs to succeed. Find out more about British Standards by visiting our website at bsigroup.com/standards or contacting our Customer Services team or Knowledge Centre.

Buying standards

You can buy and download PDF versions of BSI publications, including British and adopted European and international standards, through our website at bsigroup.com/shop, where hard copies can also be purchased.

If you need international and foreign standards from other Standards Development Organizations, hard copies can be ordered from our Customer Services team.

Subscriptions

Our range of subscription services are designed to make using standards easier for you. For further information on our subscription products go to bsigroup.com/subscriptions.

With **British Standards Online (BSOL)** you'll have instant access to over 55,000 British and adopted European and international standards from your desktop. It's available 24/7 and is refreshed daily so you'll always be up to date.

You can keep in touch with standards developments and receive substantial discounts on the purchase price of standards, both in single copy and subscription format, by becoming a **BSI Subscribing Member**.

PLUS is an updating service exclusive to BSI Subscribing Members. You will automatically receive the latest hard copy of your standards when they're revised or replaced.

To find out more about becoming a BSI Subscribing Member and the benefits of membership, please visit bsigroup.com/shop.

With a **Multi-User Network Licence (MUNL)** you are able to host standards publications on your intranet. Licences can cover as few or as many users as you wish. With updates supplied as soon as they're available, you can be sure your documentation is current. For further information, email bsmusales@bsigroup.com.

BSI Group Headquarters

389 Chiswick High Road London W4 4AL UK

Revisions

Our British Standards and other publications are updated by amendment or revision.

We continually improve the quality of our products and services to benefit your business. If you find an inaccuracy or ambiguity within a British Standard or other BSI publication please inform the Knowledge Centre.

Copyright

All the data, software and documentation set out in all British Standards and other BSI publications are the property of and copyrighted by BSI, or some person or entity that owns copyright in the information used (such as the international standardization bodies) and has formally licensed such information to BSI for commercial publication and use. Except as permitted under the Copyright, Designs and Patents Act 1988 no extract may be reproduced, stored in a retrieval system or transmitted in any form or by any means – electronic, photocopying, recording or otherwise – without prior written permission from BSI. Details and advice can be obtained from the Copyright & Licensing Department.

Useful Contacts:

Customer Services

Tel: +44 845 086 9001

Email (orders): orders@bsigroup.com

Email (enquiries): cservices@bsigroup.com

Subscriptions

Tel: +44 845 086 9001

Email: subscriptions@bsigroup.com

Knowledge Centre

Tel: +44 20 8996 7004

Email: knowledgecentre@bsigroup.com

Copyright & Licensing

Tel: +44 20 8996 7070

Email: copyright@bsigroup.com



...making excellence a habit.™