

Open end blind rivets with break pull mandrel and protruding head — St/St

1 Scope

This International Standard specifies dimensional and mechanical characteristics and application data for open end blind rivets with break pull mandrel and protruding head, with a steel body (St) and a steel mandrel (St) and with nominal diameters, d , from 2,4 mm up to and including 6,4 mm.

2 Normative references

The following normative documents contain provisions which, through reference in this text, constitute provisions of this International Standard. For dated references, subsequent amendments to, or revisions of, any of these publications do not apply. However, parties to agreements based on this International Standard are encouraged to investigate the possibility of applying the most recent editions of the normative documents indicated below. For undated references, the latest edition of the normative document referred to applies. Members of ISO and IEC maintain registers of currently valid International Standards.

ISO 3269:2000, *Fasteners — Acceptance inspection*

ISO 4042:1999, *Fasteners — Electroplated coatings*

ISO 4520:1981, *Chromate conversion coatings of electroplated zinc and cadmium coatings*

ISO 14588:2000, *Blind rivets — Terminology and definitions*

ISO 14589:2000, *Blind rivets — Mechanical testing*

3 Dimensions

3.1 General

Symbols and designations of dimensions are specified in ISO 14588.

3.2 Rivet dimensions

See Figure 1 and Table 1.

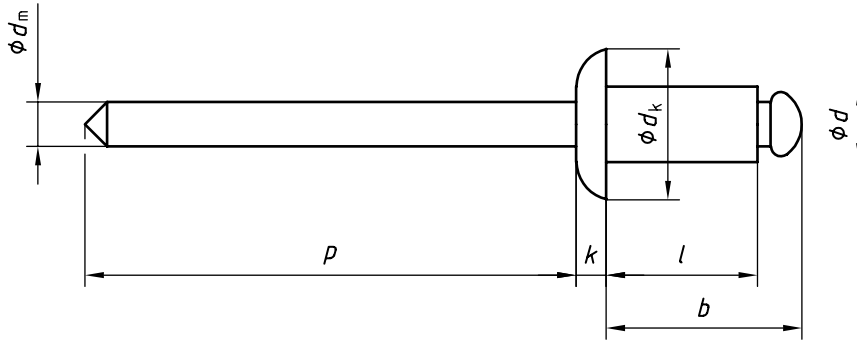

Figure 1 — Rivet dimensions

Table 1 — Rivet dimensions

Dimensions in millimetres

		nom.	2,4	3	3,2	4	4,8	5	6	6,4
Rivet body	d	max.	2,48	3,08	3,28	4,08	4,88	5,08	6,08	6,48
		min.	2,25	2,85	3,05	3,85	4,65	4,85	5,85	6,25
	d_k	max.	5,0	6,3	6,7	8,4	10,1	10,5	12,6	13,4
		min.	4,2	5,4	5,8	6,9	8,3	8,7	10,8	11,6
	k	max.	1	1,3	1,3	1,7	2	2,1	2,5	2,7
Mandrel	d_m	max.	1,5	2,15	2,15	2,8	3,5	3,5	3,4	4
	p	min.	25	25	25	27	27	27	27	27
Blind length	b	max.	$l_{max} + 3,5$	$l_{max} + 3,5$	$l_{max} + 4$	$l_{max} + 4$	$l_{max} + 4,5$	$l_{max} + 4,5$	$l_{max} + 5$	$l_{max} + 5,5$
Rivet length		Recommended grip ranges^a								
	l^b									
	nom. = min.	max.								
	6	7	0,5 to 3,5	0,5 to 3,0	1 to 3	—	—	—	—	—
	8	9	3,5 to 5,5	3 to 5	3 to 5	2,5 to 4,0	—	—	—	—
	10	11	—	5,0 to 6,5	5,0 to 6,5	4 to 6	3 to 4	3 to 4	3 to 4	3 to 4
	12	13	5,5 to 9,5	6,5 to 8,0	6,5 to 9,0	6 to 8	4 to 6	4 to 6	4 to 6	4 to 6
	16	17	—	8 to 12	9 to 12	8 to 11	6 to 10	6 to 10	6 to 10	6 to 9
	20	21	—	12 to 16	12 to 16	11 to 15	10 to 14	10 to 14	10 to 14	9 to 13
	25	26	—	—	—	15,0 to 19,5	14 to 19	14 to 19	14 to 19	13 to 19
	30	31	—	—	16 to 25	19,5 to 25,0	19 to 24	19 to 24	19 to 24	19 to 24

NOTE The rivet body dimensions are generated from the design formulae specified in annex A.

^a The grip ranges of rivets with dimensions as given in Table 1, with the material combination as given in clause 4, are specified by the minimum and maximum grip lengths. The minimum grip lengths are given as a recommendation only. It may be possible to go into individual cases below the minimum values.

^b Nominal lengths greater than 30 mm shall be specified in 5 mm increments. For availability and grip range refer to manufacturer.

3.3 Clearance hole diameters

The diameters of the clearance holes, d_{h1} , to accommodate the rivet in the components to be fastened are given in Table 2.

Table 2 — Clearance hole diameters

Dimensions in millimetres

d nom.	d_{h1}	
	min.	max.
2,4	2,5	2,6
3	3,1	3,2
3,2	3,3	3,4
4	4,1	4,2
4,8	4,9	5,0
5	5,1	5,2
6	6,1	6,2
6,4	6,5	6,6

Non-conformance to the values listed in Table 2 may result in assembly difficulties and/or reduction in the shear and tensile loads specified in Table 3.

When necessary, to facilitate alignment, only the component on the access side may have a clearance hole larger than specified in Table 2 (see Figure 2). This may also result in a reduction of the shear and tensile loads specified in Table 3.

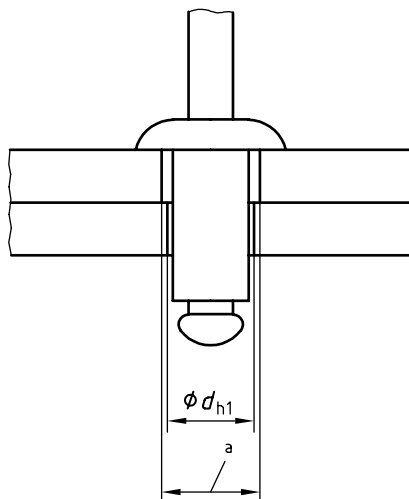

^a Enlarged clearance hole

Figure 2 — Enlarged clearance hole to facilitate alignment

4 Material and finish

Blind rivets in accordance with this International Standard shall have a rivet body made of steel (St) and a mandrel made of steel (St) and shall have mechanical properties as specified in clause 5.

Material specification is at the discretion of the manufacturer.

The surface finish of rivet body shall be zinc plated 5 μm minimum in accordance with ISO 4042. The chromate conversion coating shall be c2C in accordance with ISO 4520:1981. The complete finish designation is then Fe/Zn5c2C. The thickness shall be measured on the head.

The surface finish of the mandrel is at the discretion of the manufacturer and may be oil, phosphate and oil or zinc coating.

5 Mechanical properties

The minimum shear load, minimum tensile load and maximum mandrel break load shall be as specified in Table 3 when tested in accordance with ISO 14589.

Table 3 — Mechanical properties

<i>d</i> nom. mm	Shear load min. N	Tensile load min. N	Mandrel break load max. N
2,4	650	700	2 000
3	950	1 100	3 200
3,2	1 100	1 200	4 000
4	1 700	2 200	5 800
4,8	2 900	3 100	7 500
5	3 100	4 000	8 000
6	4 300	4 800	12 500
6,4	4 900	5 700	13 000

6 Mandrel push-out resistance

To load to push out the mandrel shall exceed 10 N when tested in accordance with ISO 14589.

7 Mandrel head retention capability

The portion of the mandrel remaining in the set rivet shall not be ejected by the application of the head retention test load specified in Table 4 when tested in accordance with ISO 14589.

Table 4 — Mandrel head retention test loads

<i>d</i> nom. mm	Head retention test load N
2,4	30
3	35
3,2	35
4	40
4,8	45
5	45
6	50
6,4	50

8 Workmanship

Rivets shall be free from burrs and harmful defects and shall have well-formed heads and shanks.

After setting, rivets shall not show evidence of cracking when viewed at 5 × magnification.

9 Acceptance testing

If there is no other agreement, acceptance inspection in accordance with ISO 3269 applies.

10 Designation

EXAMPLE An open end blind rivet, with break pull mandrel and protruding head, with nominal diameter $d = 4$ mm and nominal length $l = 12$ mm with a steel body (St) and a steel mandrel (St) is designated as follows:

Blind rivet ISO 15979 - 4 × 12 - St/St

Annex A (informative)

Design formulae

A.1 General

Blind rivets in accordance with this International Standard comply with the following design formulae and tolerances:

A.2 Shank diameter

The maximum shank diameter complies with the formula:

$$d_{\max} = d_{\text{nom}} + 0,08 \text{ mm}$$

The minimum shank diameter complies with the formula:

$$d_{\min} = d_{\text{nom}} - 0,15 \text{ mm}$$

A.3 Head diameter

The maximum head diameter complies with the formula:

$$d_{k \max} = 2,1 d_{\text{nom}}$$

rounded to one decimal place.

A.4 Head diameter tolerance

The head diameter tolerance is h16 for $d_{\text{nom}} \leq 3,2 \text{ mm}$ and h17 for $d_{\text{nom}} > 3,2 \text{ mm}$.

A.5 Head height

The maximum head height complies with the formula:

$$k_{\max} = 0,415 d_{\text{nom}}$$

rounded to one decimal place.

A.6 Clearance hole diameter

The clearance hole diameter for blind rivet application complies with the formulae:

$$d_{h1 \max} = d_{\text{nom}} + 0,2 \text{ mm}$$

$$d_{h1 \min} = d_{\text{nom}} + 0,1 \text{ mm}$$

Annex ZA
(normative)**Normative references to international publications
with their relevant European publications**

This European Standard incorporates by dated or undated reference, provisions from other publications. These normative references are cited at the appropriate places in the text and the publications are listed hereafter. For dated references, subsequent amendments to or revisions of any of these publications apply to this European Standard only when incorporated in it by amendment or revision. For undated references the latest edition of the publication referred to applies (including amendments).

NOTE Where an International Publication has been modified by common modifications, indicated by (mod.), the relevant EN/HD applies.

<u>Publication</u>	<u>Year</u>	<u>Title</u>	<u>EN</u>	<u>Year</u>
ISO 3269	2000	Fasteners - Acceptance inspection	EN ISO 3269	2000
ISO 4042	1999	Fasteners - Electroplated coatings	EN ISO 4042	1999
ISO 14588	2000	Blind rivets - Terminology and definitions	EN ISO 14588	2000
ISO 14589	2000	Blind rivets - Mechanical testing	EN ISO 14589	2000

BSI — British Standards Institution

BSI is the independent national body responsible for preparing British Standards. It presents the UK view on standards in Europe and at the international level. It is incorporated by Royal Charter.

Revisions

British Standards are updated by amendment or revision. Users of British Standards should make sure that they possess the latest amendments or editions.

It is the constant aim of BSI to improve the quality of our products and services. We would be grateful if anyone finding an inaccuracy or ambiguity while using this British Standard would inform the Secretary of the technical committee responsible, the identity of which can be found on the inside front cover.
Tel: +44 (0)20 8996 9000. Fax: +44 (0)20 8996 7400.

BSI offers members an individual updating service called PLUS which ensures that subscribers automatically receive the latest editions of standards.

Buying standards

Orders for all BSI, international and foreign standards publications should be addressed to Customer Services. Tel: +44 (0)20 8996 9001.
Fax: +44 (0)20 8996 7001. Email: orders@bsi-global.com. Standards are also available from the BSI website at <http://www.bsi-global.com>.

In response to orders for international standards, it is BSI policy to supply the BSI implementation of those that have been published as British Standards, unless otherwise requested.

Information on standards

BSI provides a wide range of information on national, European and international standards through its Library and its Technical Help to Exporters Service. Various BSI electronic information services are also available which give details on all its products and services. Contact the Information Centre.
Tel: +44 (0)20 8996 7111. Fax: +44 (0)20 8996 7048. Email: info@bsi-global.com.

Subscribing members of BSI are kept up to date with standards developments and receive substantial discounts on the purchase price of standards. For details of these and other benefits contact Membership Administration.
Tel: +44 (0)20 8996 7002. Fax: +44 (0)20 8996 7001.
Email: membership@bsi-global.com.

Information regarding online access to British Standards via British Standards Online can be found at <http://www.bsi-global.com/bsonline>.

Further information about BSI is available on the BSI website at <http://www.bsi-global.com>.

Copyright

Copyright subsists in all BSI publications. BSI also holds the copyright, in the UK, of the publications of the international standardization bodies. Except as permitted under the Copyright, Designs and Patents Act 1988 no extract may be reproduced, stored in a retrieval system or transmitted in any form or by any means – electronic, photocopying, recording or otherwise – without prior written permission from BSI.

This does not preclude the free use, in the course of implementing the standard, of necessary details such as symbols, and size, type or grade designations. If these details are to be used for any other purpose than implementation then the prior written permission of BSI must be obtained.

Details and advice can be obtained from the Copyright & Licensing Manager.
Tel: +44 (0)20 8996 7070. Fax: +44 (0)20 8996 7553.
Email: copyright@bsi-global.com.