

Closed and blind rivets with break pull mandrel and protruding head — AIA/St

The European Standard EN ISO 15973:2000 has the status of a
British Standard

ICS 21.060.40

National foreword

This British Standard is the official English language version of EN ISO 15973:2000. It is identical with ISO 15973:2000. BS EN ISO 15973:2000, together with BS EN ISO 14588:2001, BS EN ISO 14589:2001, BS EN ISO 15974:2001, BS EN ISO 15975:2002, BS EN ISO 15976:2002, BS EN ISO 15977:2002, BS EN ISO 15978:2002 and BS EN ISO 15979:2002, supersedes BS 7349-1:1993 which is withdrawn.

The UK participation in its preparation was entrusted to Technical Committee FME/6, Rivets, which has the responsibility to:

- aid enquirers to understand the text;
- present to the responsible international/European committee any enquiries on the interpretation, or proposals for change, and keep the UK interests informed;
- monitor related international and European developments and promulgate them in the UK.

A list of organizations represented on this committee can be obtained on request to its secretary.

Cross-references

The British Standards which implement international or European publications referred to in this document may be found in the *BSI Catalogue* under the section entitled “International Standards Correspondence Index”, or by using the “Search” facility of the *BSI Electronic Catalogue* or of British Standards Online.

This publication does not purport to include all the necessary provisions of a contract. Users are responsible for its correct application.

Compliance with a British Standard does not of itself confer immunity from legal obligations.

Summary of pages

This document comprises a front cover, an inside front cover, the EN ISO title page, the EN ISO foreword page, the ISO title page, pages ii and iii, a blank page, pages 1 to 5, the annex ZA page, an inside back cover and a back cover.

The BSI copyright notice displayed in this document indicates when the document was last issued.

This British Standard, having been prepared under the direction of the Engineering Sector Committee, was published under the authority of the Standards Committee and comes into effect on 15 March 2001

© BSI 22 November 2004

Amendments issued since publication

Amd. No.	Date	Comments
15342 Corrigendum No. 1	22 November 2004	Supersession details corrected

ICS 21.060.40

English version

Closed end blind rivets with break pull mandrel and protruding head - AIA/St (ISO 15973:2000)

Rivets aveugles à rupture de tige à corps fermé, à tête bombée - AIA/St (ISO 15973:2000)

Geschlossene Blindniete mit Sollbruchdorn und Flachkopf - AIA/St (ISO 15973:2000)

This European Standard was approved by CEN on 15 December 2000.

CEN members are bound to comply with the CEN/CENELEC Internal Regulations which stipulate the conditions for giving this European Standard the status of a national standard without any alteration. Up-to-date lists and bibliographical references concerning such national standards may be obtained on application to the Management Centre or to any CEN member.

This European Standard exists in three official versions (English, French, German). A version in any other language made by translation under the responsibility of a CEN member into its own language and notified to the Management Centre has the same status as the official versions.

CEN members are the national standards bodies of Austria, Belgium, Czech Republic, Denmark, Finland, France, Germany, Greece, Iceland, Ireland, Italy, Luxembourg, Netherlands, Norway, Portugal, Spain, Sweden, Switzerland and United Kingdom.



EUROPEAN COMMITTEE FOR STANDARDIZATION
COMITÉ EUROPÉEN DE NORMALISATION
EUROPÄISCHES KOMITEE FÜR NORMUNG

Management Centre: rue de Stassart, 36 B-1050 Brussels

Foreword

The text of the International Standard ISO 15973:2000 has been prepared by Technical Committee ISO/TC 2 "Fasteners" in collaboration with Technical Committee CEN/TC 185 "Threaded and non-threaded mechanical fasteners and accessories", the secretariat of which is held by DIN.

This European Standard shall be given the status of a national standard, either by publication of an identical text or by endorsement, at the latest by June 2001, and conflicting national standards shall be withdrawn at the latest by June 2001.

According to the CEN/CENELEC Internal Regulations, the national standards organizations of the following countries are bound to implement this European Standard: Austria, Belgium, Czech Republic, Denmark, Finland, France, Germany, Greece, Iceland, Ireland, Italy, Luxembourg, Netherlands, Norway, Portugal, Spain, Sweden, Switzerland and the United Kingdom.

Endorsement notice

The text of the International Standard ISO 15973:2000 was approved by CEN as a European Standard without any modification.

NOTE: Normative references to International Standards are listed in annex ZA (normative).

INTERNATIONAL
STANDARD

ISO
15973

First edition
2000-12-15

**Closed end blind rivets with break pull
mandrel and protruding head — AIA/St**

Rivets aveugles à rupture de tige à corps fermé, à tête bombée — AIA/St



Reference number
ISO 15973:2000(E)

Foreword

ISO (the International Organization for Standardization) is a worldwide federation of national standards bodies (ISO member bodies). The work of preparing International Standards is normally carried out through ISO technical committees. Each member body interested in a subject for which a technical committee has been established has the right to be represented on that committee. International organizations, governmental and non-governmental, in liaison with ISO, also take part in the work. ISO collaborates closely with the International Electrotechnical Commission (IEC) on all matters of electrotechnical standardization.

International Standards are drafted in accordance with the rules given in the ISO/IEC Directives, Part 3.

Draft International Standards adopted by the technical committees are circulated to the member bodies for voting. Publication as an International Standard requires approval by at least 75 % of the member bodies casting a vote.

Attention is drawn to the possibility that some of the elements of this International Standard may be the subject of patent rights. ISO shall not be held responsible for identifying any or all such patent rights.

International Standard ISO 15973 was prepared by Technical Committee ISO/TC 2, *Fasteners*.

Annex A of this International Standard is for information only.

Closed end blind rivets with break pull mandrel and protruding head — AIA/St

1 Scope

This International Standard specifies dimensional and mechanical characteristics and application data for closed end blind rivets with break pull mandrel and protruding head, with an aluminium alloy body (AIA) and a steel mandrel (St) and with nominal diameters from 3,2 mm up to and including 6,4 mm.

2 Normative references

The following normative documents contain provisions which, through reference in this text, constitute provisions of this International Standard. For dated references, subsequent amendments to, or revisions of, any of these publications do not apply. However, parties to agreements based on this International Standard are encouraged to investigate the possibility of applying the most recent editions of the normative documents indicated below. For undated references, the latest edition of the normative document referred to applies. Members of ISO and IEC maintain registers of currently valid International Standards.

ISO 3269:2000, *Fasteners — Acceptation inspection.*

ISO 14588:2000, *Blind rivets — Terminology and definitions.*

ISO 14589:2000, *Blind rivets — Mechanical testing.*

3 Dimensions

NOTE Symbols and designations of dimensions are specified in ISO 14588.

3.1 Rivet dimensions

See Figure 1 and Table 1.

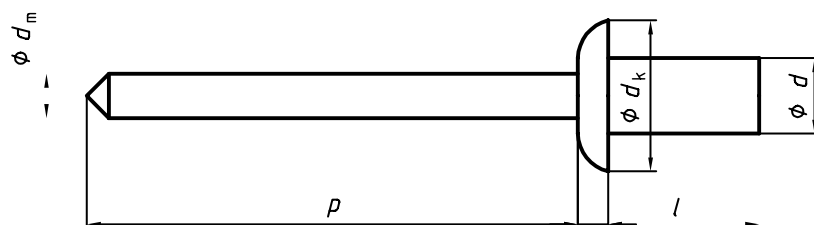

Figure 1 — Rivet dimensions

Table 1 — Rivet dimensions

Dimensions in millimetres

Rivet	d	nom.	3,2	4	4,8	6,4
		max.	3,28	4,08	4,88	6,48
		min.	3,05	3,85	4,65	6,25
	d_k	max.	6,7	8,4	10,1	13,4
		min.	5,8	6,9	8,3	11,6
	k	max.	1,3	1,7	2	2,7
Mandrel	d_m	max.	1,85	2,35	2,77	3,71
	p	min.	25	25	27	27
	l	nom. = min.	Recommended grip ranges ^a			
		max.				
	6,5	7,5	0,5 to 2,0			
	8	9	2,0 to 3,5	0,5 to 3,5		
	8,5	9,5	—	—	0,5 to 3,5	
	9,5	10,5	3,5 to 5,0	3,5 to 5,0	3,5 to 5,0	
	11	12	5,0 to 6,5	5,0 to 6,5	5,0 to 6,5	
	12,5	13,5	6,5 to 8,0	6,5 to 8,0	—	1,5 to 6,5
	13	14		—	6,5 to 8,0	—
	14,5	15,5		8 to 10	8,0 to 9,5	—
	15,5	16,5			—	6,5 to 9,5
	16	17			9,5 to 11,0	—
	18	19			11 to 13	—
	21	22			13 to 16	—
NOTE The rivet body dimensions are generated from the design formulae specified in annex A (informative).						
^a The grip ranges of rivets with dimensions as given in this table and with the material combination as given in clause 4 are specified by the minimum and maximum grip lengths. The minimum grip lengths are given as a recommendation only. It may be possible to apply lower minimum values in certain cases.						

3.2 Clearance hole diameters

The clearance hole (d_{h1}) to accommodate the rivet in the components to be fastened is shown in Figure 2 and its diameters are given in Table 2.

Nonconformance to the values in Table 2 may result in assembly difficulties and/or reduction in the shear and tensile loads specified in Table 3.

If necessary, to facilitate alignment, only the component on the access side may have a clearance hole larger than specified in Table 2, see Figure 2. This may also result in a reduction of the shear and tensile loads specified in Table 3.

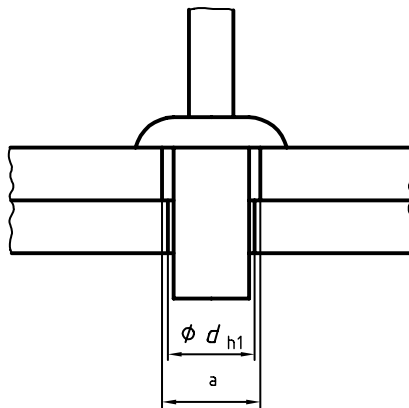

^a Enlarged clearance hole.

Figure 2 — Enlarged clearance hole to facilitate alignment

Table 2 — Clearance hole diameters

Dimensions in millimetres

<i>d</i> nom.	<i>d_{h1}</i>	
	min.	max.
3,2	3,3	3,4
4	4,1	4,2
4,8	4,9	5,0
6,4	6,5	6,6

4 Material and finish

Blind rivets in accordance with this International Standard shall have a rivet body made of aluminium alloy (AlA) and a mandrel made of steel (St) and shall have mechanical properties as specified in clause 5.

Material specification is at the discretion of the manufacturer.

The surface finish shall be natural with a protection for storage.

5 Mechanical properties

The minimum shear load, minimum tensile load and maximum mandrel break load shall be as specified in Table 3 when tested in accordance with ISO 14589.

Table 3 — Mechanical properties

<i>d</i> nom.	Shear load min.	Tensile load min.	Mandrel break load max.
mm	N	N	N
3,2	1 100	1 450	3 500
4	1 600	2 200	5 000
4,8	2 200	3 100	7 000
6,4	3 600	4 900	10 230

6 Workmanship

Rivets shall be free from burrs and harmful defects and shall have well formed heads and shanks.

After setting, rivets shall not show evidence of cracking when viewed at 5× magnification.

7 Acceptance testing

If there is no other agreement, acceptance inspection in accordance with ISO 3269 applies.

8 Designation

EXAMPLE A closed end blind rivet, with break pull mandrel and protruding head, with nominal diameter $d = 4$ mm and nominal length $l = 12,5$ mm with an aluminium alloy body (AIA) and a steel mandrel (St) is designated as follows:

Blind rivet ISO 15973 - 4 × 12,5 - AIA/St

Annex A (informative)

Design formulae

A.1 General

Blind rivets in accordance with this International Standard comply with the following design formulae and tolerances:

A.2 Shank diameter

The maximum shank diameter complies with the formula:

$$d_{\max} = d_{\text{nom}} + 0,08 \text{ mm}$$

The minimum shank diameter complies with the formula:

$$d_{\min} = d_{\text{nom}} - 0,15 \text{ mm}$$

A.3 Head diameter

The maximum head diameter complies with the formula:

$$d_{\text{kmax}} = 2,1 d_{\text{nom}}$$

rounded to one decimal place.

A.4 Head diameter tolerance

The head diameter tolerance is h16 for $d_{\text{nom}} = 3,2 \text{ mm}$ and h17 for $d_{\text{nom}} > 3,2 \text{ mm}$.

A.5 Head height

The maximum head diameter complies with the formula:

$$k = 0,415 d_{\text{nom}}$$

rounded to one decimal place.

A.6 Clearance hole diameter

The clearance hole diameter for blind rivet application complies with the formulae:

$$d_{\text{h1 max}} = d_{\text{nom}} + 0,2 \text{ mm}$$

$$d_{\text{h1 min}} = d_{\text{nom}} + 0,1 \text{ mm}$$

Annex ZA
(normative)

Normative references to international publications with their corresponding European publications

This European Standard incorporates, by dated or undated reference, provisions from other publications. These normative references are cited at the appropriate places in the text, and the publications are listed hereafter. For dated references, subsequent amendments to or revisions of any of these publications apply to this European Standard only when incorporated in it by amendment or revision. For undated references the latest edition of the publication referred to applies (including amendments).

NOTE Where an International Publication has been modified by common modifications, indicated by (mod.), the relevant EN/HD applies.

<u>Publication</u>	<u>Year</u>	<u>Title</u>	<u>EN/HD</u>	<u>Year</u>
ISO 3269	2000	Fasteners - Acceptance inspection	EN ISO 3269	2000

BSI — British Standards Institution

BSI is the independent national body responsible for preparing British Standards. It presents the UK view on standards in Europe and at the international level. It is incorporated by Royal Charter.

Revisions

British Standards are updated by amendment or revision. Users of British Standards should make sure that they possess the latest amendments or editions.

It is the constant aim of BSI to improve the quality of our products and services. We would be grateful if anyone finding an inaccuracy or ambiguity while using this British Standard would inform the Secretary of the technical committee responsible, the identity of which can be found on the inside front cover. Tel: +44 (0)20 8996 9000. Fax: +44 (0)20 8996 7400.

BSI offers members an individual updating service called PLUS which ensures that subscribers automatically receive the latest editions of standards.

Buying standards

Orders for all BSI, international and foreign standards publications should be addressed to Customer Services. Tel: +44 (0)20 8996 9001. Fax: +44 (0)20 8996 7001. Email: orders@bsi-global.com. Standards are also available from the BSI website at <http://www.bsi-global.com>.

In response to orders for international standards, it is BSI policy to supply the BSI implementation of those that have been published as British Standards, unless otherwise requested.

Information on standards

BSI provides a wide range of information on national, European and international standards through its Library and its Technical Help to Exporters Service. Various BSI electronic information services are also available which give details on all its products and services. Contact the Information Centre. Tel: +44 (0)20 8996 7111. Fax: +44 (0)20 8996 7048. Email: info@bsi-global.com.

Subscribing members of BSI are kept up to date with standards developments and receive substantial discounts on the purchase price of standards. For details of these and other benefits contact Membership Administration. Tel: +44 (0)20 8996 7002. Fax: +44 (0)20 8996 7001. Email: membership@bsi-global.com.

Information regarding online access to British Standards via British Standards Online can be found at <http://www.bsi-global.com/bsonline>.

Further information about BSI is available on the BSI website at <http://www.bsi-global.com>.

Copyright

Copyright subsists in all BSI publications. BSI also holds the copyright, in the UK, of the publications of the international standardization bodies. Except as permitted under the Copyright, Designs and Patents Act 1988 no extract may be reproduced, stored in a retrieval system or transmitted in any form or by any means – electronic, photocopying, recording or otherwise – without prior written permission from BSI.

This does not preclude the free use, in the course of implementing the standard, of necessary details such as symbols, and size, type or grade designations. If these details are to be used for any other purpose than implementation then the prior written permission of BSI must be obtained.

Details and advice can be obtained from the Copyright & Licensing Manager. Tel: +44 (0)20 8996 7070. Fax: +44 (0)20 8996 7553. Email: copyright@bsi-global.com.