

Binders for paints and varnishes — Determination of turbidity

The European Standard EN ISO 15715:2006 has the status of a
British Standard

ICS 87.060.20

National foreword

This British Standard is the official English language version of EN ISO 15715:2006. It is identical with ISO 15715:2003.

The UK participation in its preparation was entrusted to Technical Committee STI/3, Paint media and related products, which has the responsibility to:

- aid enquirers to understand the text;
- present to the responsible international/European committee any enquiries on the interpretation, or proposals for change, and keep UK interests informed;
- monitor related international and European developments and promulgate them in the UK.

A list of organizations represented on this committee can be obtained on request to its secretary.

Cross-references

The British Standards which implement international or European publications referred to in this document may be found in the *BSI Catalogue* under the section entitled “International Standards Correspondence Index”, or by using the “Search” facility of the *BSI Electronic Catalogue* or of British Standards Online.

This publication does not purport to include all the necessary provisions of a contract. Users are responsible for its correct application.

Compliance with a British Standard does not of itself confer immunity from legal obligations.

Summary of pages

This document comprises a front cover, an inside front cover, the EN ISO title page, the EN ISO foreword page, the ISO title page, pages ii to iv, pages 1 to 6, an inside back cover and a back cover.

The BSI copyright notice displayed in this document indicates when the document was last issued.

Amendments issued since publication

Amd. No.	Date	Comments
16198	31 March 2006	Renumbers BS ISO 15715:2003 as BS EN ISO 15715:2006

This British Standard was published under the authority of the Standards Policy and Strategy Committee on 4 August 2003

© BSI 2006

ISBN 0 580 42377 8

ICS 87.060.20

English Version

**Binders for paints and varnishes - Determination of turbidity (ISO
15715:2003)**

Liants pour peintures et vernis - Détermination de la
turbidité (ISO 15715:2003)

Bindemittel für Beschichtungsstoffe - Bestimmung der
Trübung (ISO 15715:2003)

This European Standard was approved by CEN on 16 January 2006.

CEN members are bound to comply with the CEN/CENELEC Internal Regulations which stipulate the conditions for giving this European Standard the status of a national standard without any alteration. Up-to-date lists and bibliographical references concerning such national standards may be obtained on application to the Central Secretariat or to any CEN member.

This European Standard exists in three official versions (English, French, German). A version in any other language made by translation under the responsibility of a CEN member into its own language and notified to the Central Secretariat has the same status as the official versions.

CEN members are the national standards bodies of Austria, Belgium, Cyprus, Czech Republic, Denmark, Estonia, Finland, France, Germany, Greece, Hungary, Iceland, Ireland, Italy, Latvia, Lithuania, Luxembourg, Malta, Netherlands, Norway, Poland, Portugal, Romania, Slovakia, Slovenia, Spain, Sweden, Switzerland and United Kingdom.



EUROPEAN COMMITTEE FOR STANDARDIZATION
COMITÉ EUROPÉEN DE NORMALISATION
EUROPÄISCHES KOMITEE FÜR NORMUNG

Management Centre: rue de Stassart, 36 B-1050 Brussels

Foreword

The text of ISO 15715:2003 has been prepared by Technical Committee ISO/TC 35 "Paints and varnishes" of the International Organization for Standardization (ISO) and has been taken over as EN ISO 15715:2006 by Technical Committee CEN/TC 139 "Paints and varnishes", the secretariat of which is held by DIN.

This European Standard shall be given the status of a national standard, either by publication of an identical text or by endorsement, at the latest by August 2006, and conflicting national standards shall be withdrawn at the latest by August 2006.

According to the CEN/CENELEC Internal Regulations, the national standards organizations of the following countries are bound to implement this European Standard: Austria, Belgium, Cyprus, Czech Republic, Denmark, Estonia, Finland, France, Germany, Greece, Hungary, Iceland, Ireland, Italy, Latvia, Lithuania, Luxembourg, Malta, Netherlands, Norway, Poland, Portugal, Romania, Slovakia, Slovenia, Spain, Sweden, Switzerland and United Kingdom.

Endorsement notice

The text of ISO 15715:2003 has been approved by CEN as EN ISO 15715:2006 without any modifications.

INTERNATIONAL
STANDARD

ISO
15715

First edition
2003-03-01

**Binders for paints and varnishes —
Determination of turbidity**

Liants pour peintures et vernis — Détermination de la turbidité



Reference number
ISO 15715:2003(E)

Contents

Page

Foreword	iv
1 Scope.....	1
2 Terms and definitions	1
3 Principle	1
4 Apparatus.....	2
5 Calibration.....	2
6 Procedure.....	3
7 Expression of results.....	3
8 Precision	3
9 Test report.....	3
Annex A (normative) Preparation of formazine standards	4
Annex B (informative) Use of additional measurement angles	5
Bibliography	6

Foreword

ISO (the International Organization for Standardization) is a worldwide federation of national standards bodies (ISO member bodies). The work of preparing International Standards is normally carried out through ISO technical committees. Each member body interested in a subject for which a technical committee has been established has the right to be represented on that committee. International organizations, governmental and non-governmental, in liaison with ISO, also take part in the work. ISO collaborates closely with the International Electrotechnical Commission (IEC) on all matters of electrotechnical standardization.

International Standards are drafted in accordance with the rules given in the ISO/IEC Directives, Part 2.

The main task of technical committees is to prepare International Standards. Draft International Standards adopted by the technical committees are circulated to the member bodies for voting. Publication as an International Standard requires approval by at least 75 % of the member bodies casting a vote.

Attention is drawn to the possibility that some of the elements of this document may be the subject of patent rights. ISO shall not be held responsible for identifying any or all such patent rights.

ISO 15715 was prepared by Technical Committee ISO/TC 35, *Paints and varnishes*, Subcommittee SC 10, *Test methods for binders for paints and varnishes*.

Binders for paints and varnishes — Determination of turbidity

1 Scope

The measurement of the turbidity of liquids can be carried out visually or by instrument, but visual methods can be subjective. This method measures instrumentally the scattering of light by the insoluble matter in a liquid and therefore gives an objective determination of turbidity.

Turbidity in liquids is caused by the presence of undissolved matter (i.e. non-settling flocculation, gels or other suspended matter such as particles or droplets). In the case of finely dispersed undissolved matter, the turbidity may be determined by measuring the intensity of the light which is scattered by the particles when a beam of light is passed through the liquid.

This International Standard specifies an instrumental method for determining the turbidity of clear liquids. It is applicable to resins and resin solutions, solvents, clear coating materials, monomers and any other liquids where clarity is specified.

2 Terms and definitions

For the purposes of this document, the following terms and definitions apply.

2.1

turbidity

reduction in the transparency of a liquid caused by the presence of undissolved matter

3 Principle

3.1 Principle of the method

A liquid sample is placed in an optical cell or glass jar and the turbidity measured on a ratio-recording turbidimeter. The instrument is calibrated in formazine turbidity units (FTUs). The turbidity of the sample can thus be read directly in FTUs. The readings are therefore insensitive to colour.

3.2 General principles of turbidity measurement

A liquid sample coloured by dissolved substances is a homogeneous system that only attenuates radiation passing through the sample. A sample containing undissolved substances not only attenuates the incident radiation but, in addition, the insoluble particles diffuse the radiation, unequally, in all directions (see Figure 1).

By determining the ratio between the light levels at 0° and 90° , a measure of the degree of scattering is obtained. A factor F relates this ratio to formazine concentration units.

The degree of scattering measured depends on the measurement angle, the particle size, the concentration of the particles, the wavelength of the light source and the complex refractive index of the particles relative to the liquid.

NOTE Instrument-to-instrument comparisons are only possible if the apparatus is used in accordance with this International Standard and the same principles of measurement are applied.

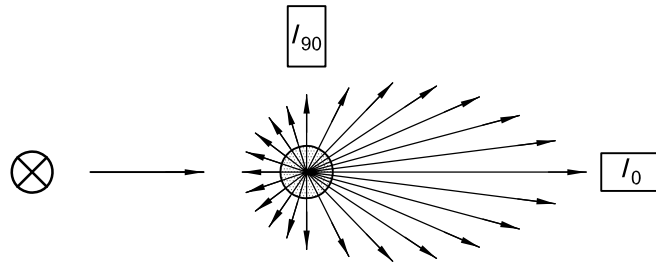

Figure 1 — Principle of measurement

4 Apparatus

4.1 Turbidimeter

Any instrument may be used provided that it complies with the following requirements:

- the wavelength λ of the incident light shall be (860 ± 30) nm;
- the spectral bandwidth $\Delta\lambda$ of the incident light shall be less than or equal to 60 nm;
- the incident light beam shall not be divergent, and any convergence shall not exceed $1,5^\circ$;
- the angle between the axis of the incident beam and that at which the scattered radiation is measured shall be $(90 \pm 1)^\circ$ (see Annex B);
- the angle subtended by the aperture in the test sample shall be less than 20° .

4.2 Measurement cells

The turbidity of the sample shall be measured with the test sample either in optical cells meeting the specifications of the instrument manufacturer or in disposable glass jars.

If disposable glass jars are used, the following additional requirements apply:

- the jar shall be cylindrical;
- the diameter of the jar shall be between 5 cm and 11 cm;
- the instrument shall have provisions for automatically centering and rotating the jar during measurement;
- the part of the sample chamber not occupied by the jar shall be kept filled with tap water flowing continuously through the chamber, to eliminate refraction effects caused by inhomogeneous sample jars.

5 Calibration

Calibrate the apparatus, operating it in accordance with the manufacturer's instructions, using formazine standard matching solutions. For the preparation of the formazine standards, see Annex A. Plot a graph comprising at least five points in each measurement range (for example for the range 0,1 FTU to 5,0 FTU, make measurements at 0,5 FTU, 1,0 FTU, 2,0 FTU, 3,0 FTU and 4,0 FTU).

Repeat the calibration at frequent intervals.

NOTE A turbidity corresponding to 0 FTU cannot be measured because of scattering of radiation by the molecules themselves.

6 Procedure

Carefully fill a clean, dry optical cell or glass jar to within a centimetre of the top, pouring the sample down the side of the cell or jar to minimize bubble formation. Cap the cell or jar tightly. If bubbles are observed, allow them to dissipate before making the measurement. Bubbles will produce erroneously high results. In most cases, bubbles may be removed rapidly by using an ultrasonic bath, centrifuging, warming or placing under a slight vacuum. Verify that any such treatment of the test sample does not alter its turbidity.

Wipe off any dirt or drips, with the aid of a suitable solvent, from the outside of the cell or jar before making the measurement.

Condition the test sample to room temperature.

Place the cell or jar in the instrument, start the measurement and record the reading. Use the lowest range setting possible.

7 Expression of results

Report the result in formazine turbidity units (FTUs), as follows:

- a) if the turbidity is less than 1 FTU, to the nearest 0,01 FTU;
- b) if the turbidity is greater than or equal to 1 FTU but less than 10 FTU, to the nearest 0,1 FTU;
- c) if the turbidity is greater than or equal to 10 FTU but less than 100 FTU, to the nearest 1 FTU;
- d) if the turbidity is greater than or equal to 100 FTU, to the nearest 10 FTU.

8 Precision

No data available yet.

9 Test report

The test report shall contain at least the following information:

- a) a reference to this International Standard (ISO 15715);
- b) all details necessary to identify the product tested;
- c) the result of the test, as indicated in Clause 7;
- d) details of any deviation from the test method specified, as well as details of any circumstances which might have influenced the result;
- e) details of any items which were agreed between the interested parties;
- f) the date of the test.

Annex A (normative)

Preparation of formazine standards

A.1 Purification of water

Soak a membrane filter of pore size 0,1 µm (of the type used for bacteriological studies) for 1 h in 100 ml of distilled water. Filter 250 ml of distilled water through it and discard the water. Then pass 500 ml of distilled water twice through the membrane and reserve this water for the preparation of standard solutions.

A.2 Preparation of stock solutions of formazine (C₂H₄N₂)

Formazine is not available commercially and shall therefore be prepared as follows:

Dissolve 10,0 g of hexamethylenetetramine (C₆H₁₂N₄) in purified water (see Clause A.1) in a 100 ml graduated flask and make up to the mark (solution A).

Dissolve 1,0 g of hydrazine sulfate (N₂H₆SO₄) in purified water in a 100 ml graduated flask and make up to the mark (solution B).

WARNING — Hydrazine sulfate is poisonous and may be carcinogenic.

Mix 5 ml of solution A with 5 ml of solution B in a 100 ml graduated flask. Leave for 24 h at (25 ± 3) °C. Then make up to the mark with purified water.

The turbidity of this stock solution in formazine turbidity units is 400 FTU.

The solution is stable for about 4 weeks if stored at a temperature of (25 ± 3) °C in the dark.

A.3 Preparation of standard matching solutions

Dilute the stock solution (see Clause A.2) with purified water using pipettes and graduated flasks to obtain standard matching solutions of turbidities in the range of interest (see Table B.1 for examples). These solutions are only stable for 1 week.

Table A.1 — Examples of dilution of stock solution

Turbidity FTU	Volume of stock solution in 1 l of standard matching solution ml
400	1 000
100	250
20	50
2	5

Annex B (informative)

Use of additional measurement angles

Comparison of results obtained at different measurement angles can give additional information on the type of turbidity.

Figure B.1 illustrates this effect: The two curves represent the relative intensity of scattered light for two different particle sizes. The smaller inner curve is for a particle size of $0,05\ \mu\text{m}$, while the larger outer curve is for particles having a diameter of $5\ \mu\text{m}$. The intensity is given by the distance from the centre to the curve.

For the small particles, the intensities at 90° and, in this example, 25° are close to each other. For the large particles, the 25° value is much higher than the 90° value.

This information can be useful in deciding whether existing turbidity can be removed. If the turbidity values at different angles indicate large particles, filtration, for example, might be successful.

The second angle is usually chosen between 0° and 30° .

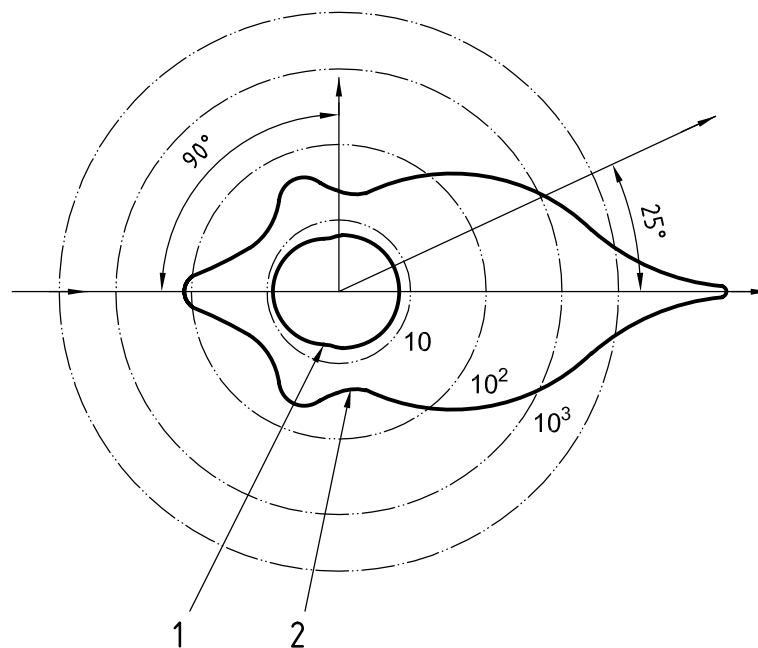

Key

- 1 curve for $0,05\ \mu\text{m}$ particles
- 2 curve for $5\ \mu\text{m}$ particles

Figure B.1 — Response curves for different particle sizes

Bibliography

- [1] ISO 7027:1999, *Water quality — Determination of turbidity*

BSI — British Standards Institution

BSI is the independent national body responsible for preparing British Standards. It presents the UK view on standards in Europe and at the international level. It is incorporated by Royal Charter.

Revisions

British Standards are updated by amendment or revision. Users of British Standards should make sure that they possess the latest amendments or editions.

It is the constant aim of BSI to improve the quality of our products and services. We would be grateful if anyone finding an inaccuracy or ambiguity while using this British Standard would inform the Secretary of the technical committee responsible, the identity of which can be found on the inside front cover. Tel: +44 (0)20 8996 9000. Fax: +44 (0)20 8996 7400.

BSI offers members an individual updating service called PLUS which ensures that subscribers automatically receive the latest editions of standards.

Buying standards

Orders for all BSI, international and foreign standards publications should be addressed to Customer Services. Tel: +44 (0)20 8996 9001. Fax: +44 (0)20 8996 7001. Email: orders@bsi-global.com. Standards are also available from the BSI website at <http://www.bsi-global.com>.

In response to orders for international standards, it is BSI policy to supply the BSI implementation of those that have been published as British Standards, unless otherwise requested.

Information on standards

BSI provides a wide range of information on national, European and international standards through its Library and its Technical Help to Exporters Service. Various BSI electronic information services are also available which give details on all its products and services. Contact the Information Centre. Tel: +44 (0)20 8996 7111. Fax: +44 (0)20 8996 7048. Email: info@bsi-global.com.

Subscribing members of BSI are kept up to date with standards developments and receive substantial discounts on the purchase price of standards. For details of these and other benefits contact Membership Administration. Tel: +44 (0)20 8996 7002. Fax: +44 (0)20 8996 7001. Email: membership@bsi-global.com.

Information regarding online access to British Standards via British Standards Online can be found at <http://www.bsi-global.com/bsonline>.

Further information about BSI is available on the BSI website at <http://www.bsi-global.com>.

Copyright

Copyright subsists in all BSI publications. BSI also holds the copyright, in the UK, of the publications of the international standardization bodies. Except as permitted under the Copyright, Designs and Patents Act 1988 no extract may be reproduced, stored in a retrieval system or transmitted in any form or by any means – electronic, photocopying, recording or otherwise – without prior written permission from BSI.

This does not preclude the free use, in the course of implementing the standard, of necessary details such as symbols, and size, type or grade designations. If these details are to be used for any other purpose than implementation then the prior written permission of BSI must be obtained.

Details and advice can be obtained from the Copyright & Licensing Manager. Tel: +44 (0)20 8996 7070. Fax: +44 (0)20 8996 7553. Email: copyright@bsi-global.com.