

BS EN ISO 15630-2:2010



BSI Standards Publication

# Steel for the reinforcement and prestressing of concrete — Test methods

Part 2: Welded fabric

**bsi.**

...making excellence a habit.™

### National foreword

This British Standard is the UK implementation of EN ISO 15630-2:2010. It supersedes BS EN ISO 15630-2:2002 which is withdrawn.

The UK participation in its preparation was entrusted to Technical Committee ISE/104, Concrete Reinforcing and Pre-Stressing Steels.

A list of organizations represented on this committee can be obtained on request to its secretary.

This publication does not purport to include all the necessary provisions of a contract. Users are responsible for its correct application.

© BSI 2010

ISBN 978 0 580 58490 9

ICS 77.140.15; 91.080.40

**Compliance with a British Standard cannot confer immunity from legal obligations.**

This British Standard was published under the authority of the Standards Policy and Strategy Committee on 30 November 2010.

### Amendments issued since publication

Date	Text affected
------	---------------

---

English Version

Steel for the reinforcement and prestressing of concrete - Test  
methods - Part 2: Welded fabric (ISO 15630-2:2010)

Aciers pour l'armature et la précontrainte du béton -  
Méthodes d'essai - Partie 2: Treillis soudés (ISO 15630-  
2:2010)

Stähle für die Bewehrung und das Vorspannen von Beton -  
Prüfverfahren - Teil 2: Geschweißte Matten (ISO 15630-  
2:2010)

This European Standard was approved by CEN on 14 October 2010.

CEN members are bound to comply with the CEN/CENELEC Internal Regulations which stipulate the conditions for giving this European Standard the status of a national standard without any alteration. Up-to-date lists and bibliographical references concerning such national standards may be obtained on application to the CEN Management Centre or to any CEN member.

This European Standard exists in three official versions (English, French, German). A version in any other language made by translation under the responsibility of a CEN member into its own language and notified to the CEN Management Centre has the same status as the official versions.

CEN members are the national standards bodies of Austria, Belgium, Bulgaria, Croatia, Cyprus, Czech Republic, Denmark, Estonia, Finland, France, Germany, Greece, Hungary, Iceland, Ireland, Italy, Latvia, Lithuania, Luxembourg, Malta, Netherlands, Norway, Poland, Portugal, Romania, Slovakia, Slovenia, Spain, Sweden, Switzerland and United Kingdom.



EUROPEAN COMMITTEE FOR STANDARDIZATION  
COMITÉ EUROPÉEN DE NORMALISATION  
EUROPÄISCHES KOMITEE FÜR NORMUNG

Management Centre: Avenue Marnix 17, B-1000 Brussels

## Foreword

The text of ISO 15630-2:2010 has been prepared by Technical Committee ISO/TC 17 "Steel" of the International Organization for Standardization (ISO) and has been taken over as EN ISO 15630-2:2010 by Technical Committee ECISS/TC 104 "Concrete reinforcing and prestressing steels" the secretariat of which is held by DIN.

This European Standard shall be given the status of a national standard, either by publication of an identical text or by endorsement, at the latest by April 2011, and conflicting national standards shall be withdrawn at the latest by April 2011.

Attention is drawn to the possibility that some of the elements of this document may be the subject of patent rights. CEN [and/or CENELEC] shall not be held responsible for identifying any or all such patent rights.

This document supersedes EN ISO 15630-2:2002.

According to the CEN/CENELEC Internal Regulations, the national standards organizations of the following countries are bound to implement this European Standard: Austria, Belgium, Bulgaria, Croatia, Cyprus, Czech Republic, Denmark, Estonia, Finland, France, Germany, Greece, Hungary, Iceland, Ireland, Italy, Latvia, Lithuania, Luxembourg, Malta, Netherlands, Norway, Poland, Portugal, Romania, Slovakia, Slovenia, Spain, Sweden, Switzerland and the United Kingdom.

### Endorsement notice

The text of ISO 15630-2:2010 has been approved by CEN as a EN ISO 15630-2:2010 without any modification.

# Contents

Page

Foreword .....	iv
Introduction.....	v
<b>1</b> <b>Scope</b> .....	<b>1</b>
<b>2</b> <b>Normative references</b> .....	<b>1</b>
<b>3</b> <b>Symbols</b> .....	<b>1</b>
<b>4</b> <b>General provisions concerning test pieces</b> .....	<b>2</b>
<b>5</b> <b>Tensile test</b> .....	<b>3</b>
5.1 <b>Test piece</b> .....	<b>3</b>
5.2 <b>Test equipment</b> .....	<b>3</b>
5.3 <b>Test procedure</b> .....	<b>3</b>
<b>6</b> <b>Bend test on welded intersection</b> .....	<b>4</b>
6.1 <b>Test piece</b> .....	<b>4</b>
6.2 <b>Test equipment</b> .....	<b>4</b>
6.3 <b>Test procedure</b> .....	<b>5</b>
6.4 <b>Interpretation of test results</b> .....	<b>5</b>
<b>7</b> <b>Determination of the weld shear force (<math>F_S</math>)</b> .....	<b>6</b>
7.1 <b>Test piece</b> .....	<b>6</b>
7.2 <b>Test equipment</b> .....	<b>6</b>
7.3 <b>Test procedure</b> .....	<b>11</b>
<b>8</b> <b>Axial force fatigue test</b> .....	<b>11</b>
8.1 <b>Principle of test</b> .....	<b>11</b>
8.2 <b>Test piece</b> .....	<b>11</b>
8.3 <b>Test equipment</b> .....	<b>11</b>
8.4 <b>Test procedure</b> .....	<b>12</b>
8.4.1 <b>Provisions concerning the test piece</b> .....	<b>12</b>
8.4.2 <b>Upper force (<math>F_{up}</math>) and force range (<math>F_r</math>)</b> .....	<b>12</b>
8.4.3 <b>Stability of force and frequency</b> .....	<b>12</b>
8.4.4 <b>Counting of force cycles</b> .....	<b>12</b>
8.4.5 <b>Frequency</b> .....	<b>12</b>
8.4.6 <b>Temperature</b> .....	<b>12</b>
8.4.7 <b>Validity of the test</b> .....	<b>12</b>
<b>9</b> <b>Chemical analysis</b> .....	<b>12</b>
<b>10</b> <b>Measurement of the geometrical characteristics of the fabric</b> .....	<b>13</b>
10.1 <b>Test piece</b> .....	<b>13</b>
10.2 <b>Test equipment</b> .....	<b>13</b>
10.3 <b>Test procedure</b> .....	<b>13</b>
<b>11</b> <b>Test report</b> .....	<b>13</b>
<b>Bibliography</b> .....	<b>14</b>

## Foreword

ISO (the International Organization for Standardization) is a worldwide federation of national standards bodies (ISO member bodies). The work of preparing International Standards is normally carried out through ISO technical committees. Each member body interested in a subject for which a technical committee has been established has the right to be represented on that committee. International organizations, governmental and non-governmental, in liaison with ISO, also take part in the work. ISO collaborates closely with the International Electrotechnical Commission (IEC) on all matters of electrotechnical standardization.

International Standards are drafted in accordance with the rules given in the ISO/IEC Directives, Part 2.

The main task of technical committees is to prepare International Standards. Draft International Standards adopted by the technical committees are circulated to the member bodies for voting. Publication as an International Standard requires approval by at least 75 % of the member bodies casting a vote.

Attention is drawn to the possibility that some of the elements of this document may be the subject of patent rights. ISO shall not be held responsible for identifying any or all such patent rights.

ISO 15630-2 was prepared by Technical Committee ISO/TC 17, *Steel*, Subcommittee SC 16, *Steels for the reinforcement and prestressing of concrete*.

This second edition cancels and replaces the first edition (ISO 15630-2:2002), which has been technically revised.

ISO 15630 consists of the following parts, under the general title *Steel for the reinforcement and prestressing of concrete — Test methods*:

- *Part 1: Reinforcing bars, wire rod and wire*
- *Part 2: Welded fabric*
- *Part 3: Prestressing steel*

## Introduction

The aim of ISO 15630 is to provide all relevant test methods for reinforcing and prestressing steels in one standard. In that context, the existing International Standards for testing these products have been revised and updated. Some further test methods have been added.

Reference is made to International Standards on the testing of metals, in general, as they are applicable. Complementary provisions have been given if needed.





# Steel for the reinforcement and prestressing of concrete — Test methods —

## Part 2: Welded fabric

### 1 Scope

This part of ISO 15630 specifies test methods applicable to welded fabric for the reinforcement of concrete.

NOTE In some countries, the expression “welded wire reinforcement” is used in place of “welded (wire) fabric”.

For those tests not specified in this part of ISO 15630 (e.g. bend test, rib/indentation geometry, mass per metre), ISO 15630-1 is applicable.

### 2 Normative references

The following referenced documents are indispensable for the application of this document. For dated references, only the edition cited applies. For undated references, the latest edition of the referenced document (including any amendments) applies.

ISO 6892-1, *Metallic materials — Tensile testing — Part 1: Method of test at room temperature*

ISO 7500-1, *Metallic materials — Verification of static uniaxial testing machines — Part 1: Tension/compression testing machines — Verification and calibration of the force-measuring system*

ISO 9513, *Metallic materials — Calibration of extensometers used in uniaxial testing*

### 3 Symbols

The symbols used in this part of ISO 15630 are given in Table 1.

Table 1 — Symbols

Symbol	Unit	Description	Reference
$A$	%	Percentage elongation after fracture	5.1, 5.3
$A_g$	%	Percentage non-proportional elongation at maximum force ( $F_m$ )	5.3
$A_{gt}$	%	Percentage total elongation at maximum force ( $F_m$ )	Clause 5
$d$	mm	Nominal diameter of the bar or wire	5.3, 7.2, 8.4.7
$D$	mm	Diameter of the mandrel of the bending device in the bend test on a welded intersection	6.2.1 (Figure 2), 6.3
$f$	Hz	Frequency of force cycles in the axial force fatigue test	8.1, 8.4.3
$F_m$	N	Maximum force in the tensile test	5.3
$F_r$	N	Force range in the axial force fatigue test	8.1, 8.3, 8.4.2, 8.4.3
$F_s$	N	Weld shear force	Clause 7
$F_{up}$	N	Upper force in the axial force fatigue test	8.1, 8.3, 8.4.2, 8.4.3
$r_1$	mm	Distance between the grips and the gauge length for the manual measurement of $A_{gt}$	5.3
$r_2$	mm	Distance between the fracture and the gauge length for the manual measurement of $A_{gt}$	5.3
$R_{eH}$	MPa	Upper yield strength	5.3
$R_m$	MPa	Tensile strength	5.3
$R_{p0,2}$	MPa	0,2 % proof strength, non-proportional extension	5.2, 5.3
$S_n$	mm <sup>2</sup>	Nominal cross-sectional area of the bar or wire	8.4.2
$\gamma$	°	Angle of bend in the bend test on a welded intersection	6.3
$2\sigma_a$	MPa	Stress range in the axial force fatigue test	8.4.2
$\sigma_{max}$	MPa	Maximum stress in the axial force fatigue test	8.4.2
NOTE 1 MPa = 1 N/mm <sup>2</sup> .			

#### 4 General provisions concerning test pieces

Unless otherwise agreed or specified in the product standard, the test pieces shall be taken from the welded fabric in the as-delivered condition.

In the case of a curved test piece, the test piece shall be straightened prior to any tests by a bend operation with a minimum amount of plastic deformation.

NOTE The straightness of the test piece is critical for the tensile test and the fatigue test.

The means of straightening the test piece (manual, machine) shall be indicated in the test report<sup>1)</sup>.

For the determination of the mechanical properties in the tensile test and the fatigue test, the test piece may be artificially aged, depending on the requirements of the relevant product standard.

1) For routine tests conducted by the reinforcing steel producers, the test information, including the test piece condition and method of straightening, should be contained within internal documentation.

If the product standard does not specify the ageing treatment, the following conditions should be applied: heating the test piece to 100 °C, maintaining at this temperature  $\pm 10$  °C for a period of  $1\text{ h}_0^{+15}$  min and then cooling in still air to the ambient temperature.

If an ageing treatment is applied to the test piece, the conditions of the ageing treatment shall be stated in the test report.

The test piece shall include at least one welded intersection.

Cross wires or bars, and the wire or bar not to be tested in a twin-wire or -bar sample, shall be cut off before the test without damaging the wire or bar to be tested or the weld under test.

## 5 Tensile test

### 5.1 Test piece

In addition to the general provisions given in Clause 4, the free length of the test piece shall be sufficient for the determination of percentage elongations in accordance with 5.3.

If the percentage elongation after fracture ( $A$ ) is determined manually, the test piece shall be marked in accordance with ISO 6892-1.

If the percentage total elongation at maximum force ( $A_{gt}$ ) is determined by the manual method, equidistant marks shall be made on the free length of the test piece (see ISO 6892-1). The distance between the marks shall be 20 mm, 10 mm or 5 mm, depending on the bar or wire diameter.

### 5.2 Test equipment

The testing machine shall be verified and calibrated in accordance with ISO 7500-1 and shall be at least of class 1.

If an extensometer is used, it shall be of class 1 in accordance with ISO 9513 for the determination of  $R_{p0,2}$ ; for the determination of  $A_{gt}$ , a class 2 extensometer (see ISO 9513) may be used.

Any extensometer used for the determination of the percentage total elongation at maximum force ( $A_{gt}$ ) shall have a gauge length of at least 100 mm. The gauge length shall be indicated in the test report.

### 5.3 Test procedure

The tensile test shall be carried out in accordance with ISO 6892-1. For the determination of  $R_{p0,2}$ , if the straight portion of the force-extension diagram is limited or not clearly defined, one of the following methods shall be applied:

- the procedure recommended in ISO 6892-1;
- the straight portion of the force-extension diagram shall be considered as the line joining the points corresponding to  $0,2F_m$  and  $0,5F_m$ .

In case of dispute, the second procedure shall be applied.

The test may be considered invalid if the slope of this line differs by more than 10 % from the theoretical value of the modulus of elasticity.

For the calculation of tensile properties ( $R_{eH}$  or  $R_{p0,2}$ ,  $R_m$ ), the nominal cross-sectional area shall be used, unless otherwise specified in the relevant product standard.

Where fracture occurs in the grips or at a distance from the grips of less than 20 mm or  $d$  (whichever is the greater), the test may be considered as invalid.

For the determination of percentage elongation after fracture ( $A$ ), the original gauge length shall be 5 times the nominal diameter ( $d$ ), unless otherwise specified in the relevant product standard. In case of dispute,  $A$  shall be determined manually.

For the determination of the percentage total elongation at maximum force ( $A_{gt}$ ), ISO 6892-1 shall be applied with the following modification:

- if  $A_{gt}$  is determined by the manual method after fracture,  $A_{gt}$  shall be calculated from the following formula:

$$A_{gt} = A_g + R_m / 2\ 000 \quad (1)$$

where  $A_g$  is the percentage non-proportional elongation at maximum force.

The measurement of  $A_g$  shall be made on the longer of the two broken parts of the test piece on a gauge length of 100 mm, as close as possible to the fracture but at a distance,  $r_2$ , of at least 50 mm or  $2d$  (whichever is the greater) away from the fracture. This measurement may be considered as invalid if the distance,  $r_1$ , between the grips and the gauge length is less than 20 mm or  $d$  (whichever is the greater). See Figure 1.

In case of dispute, the manual method shall apply.

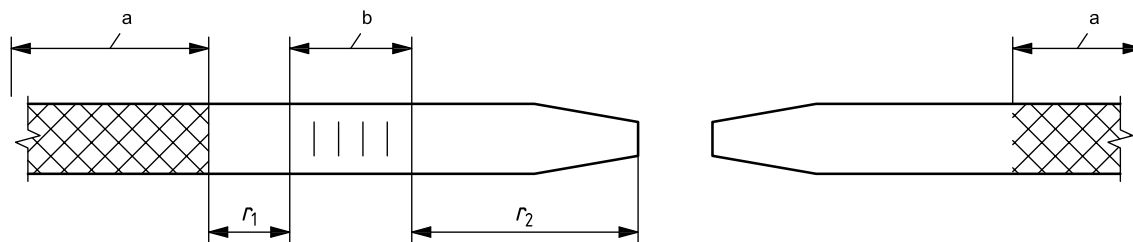

- a Grip length.
- b Gauge length 100 mm.

Figure 1 — Measurement of  $A_{gt}$  by the manual method

## 6 Bend test on welded intersection

### 6.1 Test piece

The general provisions given in Clause 4 apply.

For welded fabric with single wires or bars in both directions, the thicker wire or bar shall be submitted to bending.

For welded fabric with twin wires or bars, one of the twin wires or bars shall be submitted to bending.

### 6.2 Test equipment

6.2.1 A bending device, the principle of which is shown in Figure 2, shall be used.

NOTE Figure 2 shows a configuration where the mandrel and support rotate and the carrier is locked. It is also possible that the carrier rotates and the support or mandrel is locked.

**6.2.2** The bend test may also be carried out by using a device with supports and a mandrel (e.g. see ISO 7438).

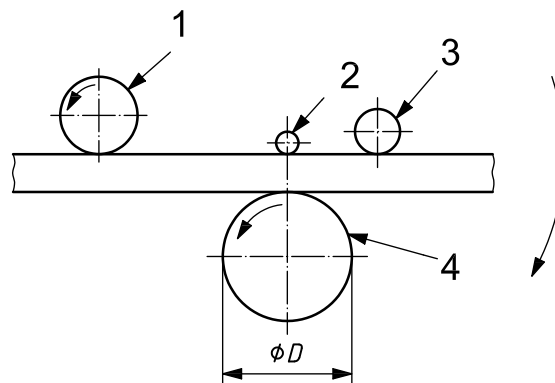

**Key**

- 1 support
- 2 crossing wire
- 3 carrier
- 4 mandrel

**Figure 2 — Principle of a bending device**

**6.3 Test procedure**

The bend test shall be carried out at a temperature between 10 °C and 35 °C, unless otherwise agreed by the parties involved.

For testing at a low temperature, if the agreement does not specify all the testing conditions, a deviation of  $\pm 2$  °C on the agreed temperature should be applied. The test piece should be immersed in the cooling medium for a sufficient time to ensure that the required temperature is reached throughout the test piece (for example, at least 10 min in a liquid medium or at least 30 min in a gaseous medium). The bend test should start within 5 s from removal from the medium. The transfer device should be designed and used in such a way that the temperature of the test piece is maintained within the temperature range.

The test piece shall be bent over a mandrel so that the weld will be in the centre of the bent portion of the test piece and in the zone under tension.

The angle of bend ( $\gamma$ ) and the diameter of the mandrel ( $D$ ) shall be in accordance with the relevant product standard.

**6.4 Interpretation of test results**

The interpretation of the bend test shall be carried out in accordance with the requirements of the relevant product standard.

If these requirements are not specified, the absence of cracks visible to a person with normal or corrected vision is considered as evidence that the test piece has withstood the bend test.

A superficial ductile tear may occur at the base of the ribs or indentations and is not considered to be a failure. The tear may be considered superficial when the depth of the tear is not greater than the width of the tear.

## 7 Determination of the weld shear force ( $F_s$ )

### 7.1 Test piece

The general provisions given in Clause 4 shall apply.

For welded fabric with single wires or bars in both directions, the thicker wire or bar shall be used as the pulling wire or bar.

For welded fabric with twin wires or bars, one of the twin wires or bars shall be the pulling wire or bar.

Test pieces previously subjected to tensile testing may be used for the weld shear test, provided that the necking at the fracture is clear of the weld zone.

### 7.2 Test equipment

The tensile testing machine shall be verified in accordance with ISO 7500-1 and shall be of class 1 or better.

The holder for the support of the test piece shall be of one of the following three types.

- Type a: the cross wire or bar is simply supported by a smooth steel plate, with a slot for the pulling wire or bar. Neither the deflection of the pulling wire or bar nor the rotation of the cross wire or bar is prevented [see Figure 3 a)];
- Type b: in addition to the provisions applicable to type-a holders, the deflection of the tail of the pulling wire or bar is prevented, but not the rotation of the cross wire or bar. The tail of the pulling wire or bar should be supported at a distance in the range of 30 mm to 50 mm from the support surface. The tail support shall allow small movements in the direction of the wire or bar. The side movement of the cross wire or bar, due to the reaction from the tail support, is prevented by a stopper, adjustable according to the size of the test piece. No initial compression of the joint is allowed [see Figure 3 b)];
- Type c: in addition to the provisions applicable to type-b holders, the rotation of the cross wire or bar is prevented. The cross wire or bar is firmly tightened between jaws with a suitable surface structure. The jaws will also prevent any side movement of the cross wire or bar [see Figure 3 c)].

For all types of holder, the distance between the support and the pulling wire or bar shall be as small as possible but there shall be no friction between the support and the pulling wire or bar.

Unless specified in the product standard, a holder of type c shall be used in case of dispute.

The type of holder that is used shall be stated in the test report.

NOTE 1 The support provisions with holders of type c reproduce best the support conditions of fabric in concrete.

It is recommended that the distance between the support and the pulling wire or bar be no greater than 0,5 mm for  $d \leq 9$  mm and 1 mm for  $d > 9$  mm.

NOTE 2 The choice of the support provisions will affect the test results.

NOTE 3 Figures 3 a), b) and c) show examples of holders of type a, b and c, respectively.

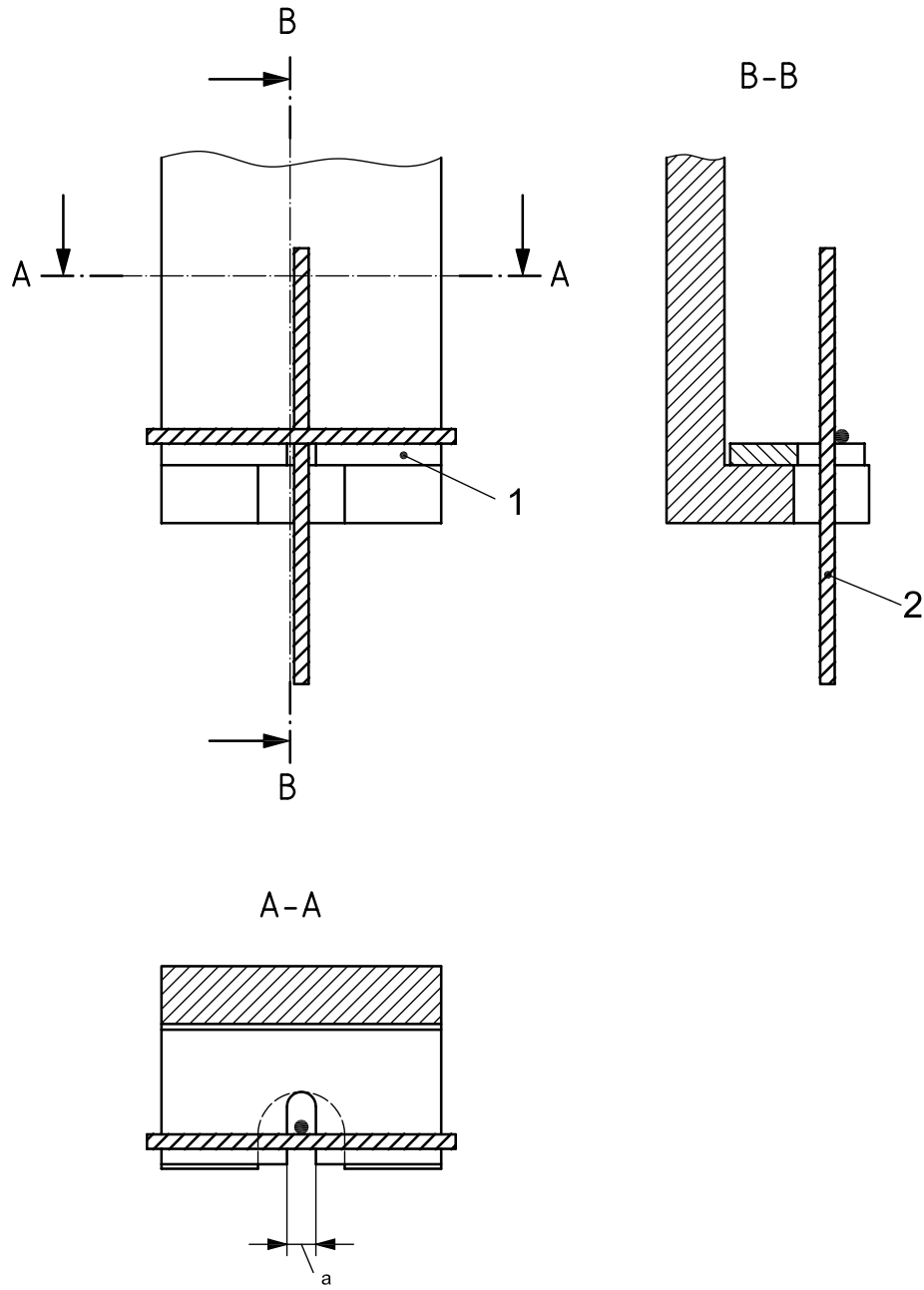

a) Example of holder of type a

Figure 3 — Examples of holders of type a, b and c (continued)

Dimension in millimetres

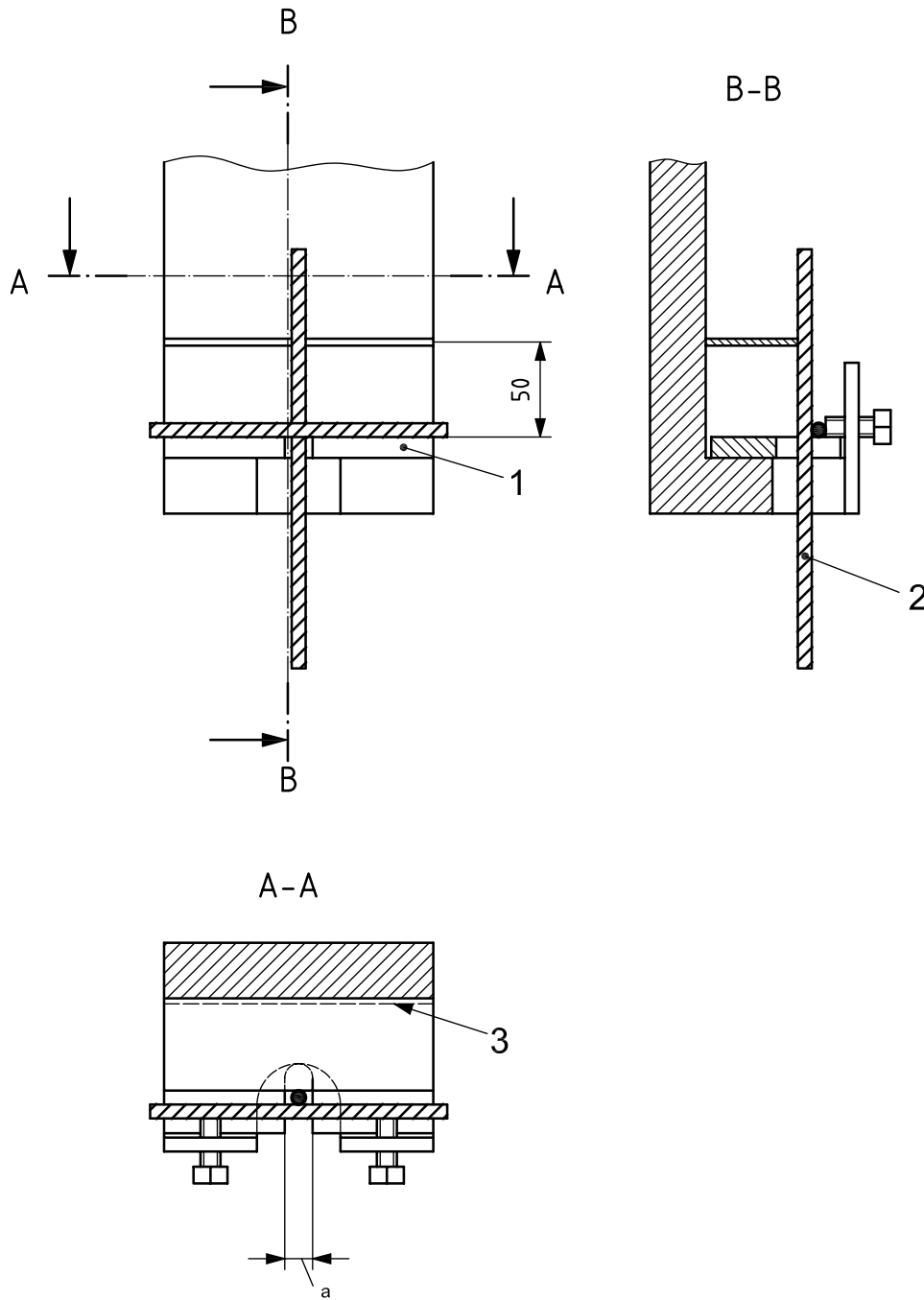

b) Example of holder of type b (continued)

Figure 3 — Examples of holders of type a, b and c (continued)



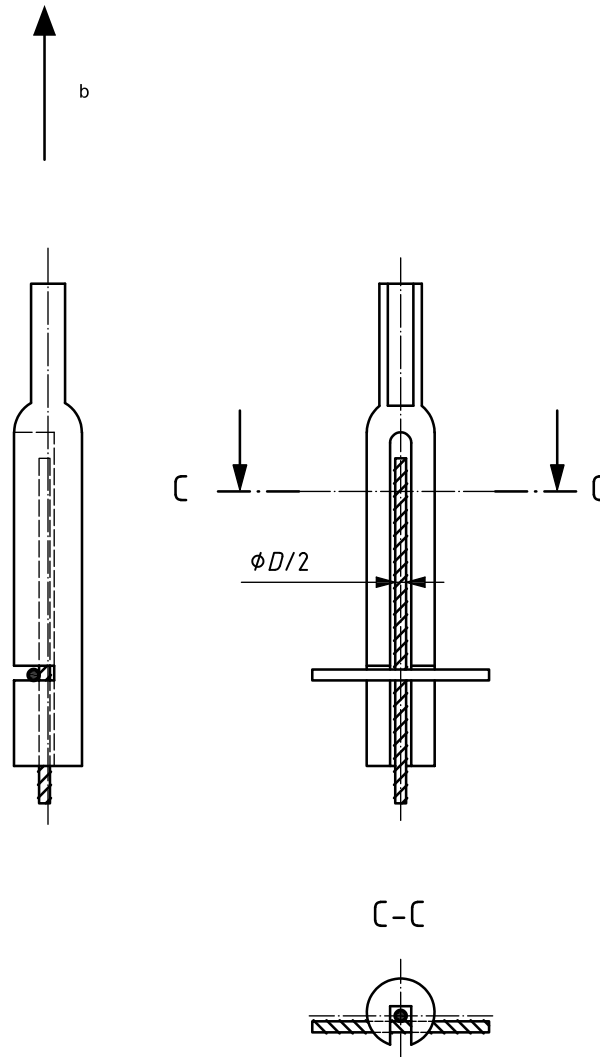

b) Example of holder of type b

Figure 3 — Examples of holders of type a, b and c (continued)

Dimension in millimetres

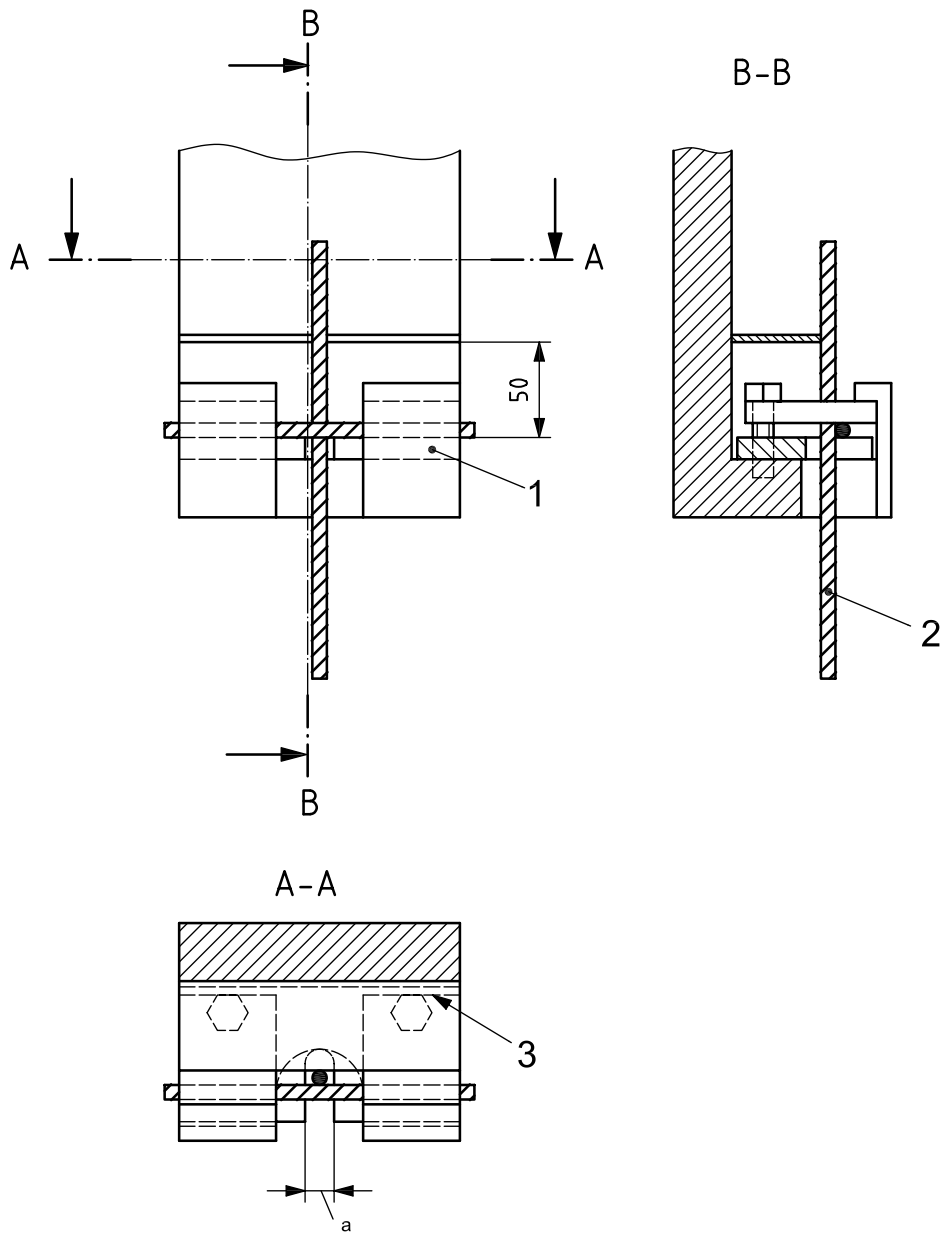

c) Example of holder of type c

**Key**

- 1 slot-adjusting plate
- 2 pulling bar
- 3 torsion spring
- a Width of slot.
- b Direction of pull.

Figure 3 — Examples of holders of type a, b and c

### 7.3 Test procedure

The test piece shall be placed on the holder.

The tensile force shall be applied to the pulling wire or bar with a stress rate between 6 MPa/s and 60 MPa/s.

The maximum force, in newtons, during the test shall be recorded.

## 8 Axial force fatigue test

### 8.1 Principle of test

The axial force fatigue test consists of submitting the test piece to an axial tensile force, which varies cyclically according to a sinusoidal wave-form of constant frequency  $f$  (see Figure 4) in the elastic range. The test is carried out until failure of the test piece, or until reaching the number of force cycles specified in the relevant product standard, without failure.

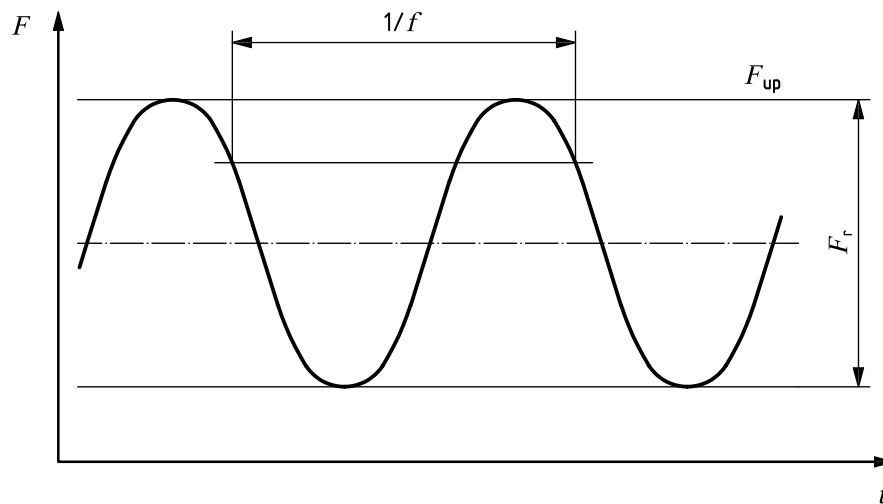

#### Key

$F$  force  
 $t$  time

Figure 4 — Force cycle diagram

### 8.2 Test piece

The general provisions given in Clause 4 shall apply.

The surface of the free length between the grips shall not be subjected to any surface treatment of any kind.

The free length shall be at least 140 mm or  $14d$ , whichever is the greater.

### 8.3 Test equipment

The fatigue-testing machine shall be calibrated in accordance with ISO 7500-1. The relative error of accuracy shall be less than or equal to  $\pm 1\%$ . The testing machine shall be capable of maintaining the upper force ( $F_{up}$ ) within  $\pm 2\%$  of the specified value, and the force range ( $F_r$ ) within  $\pm 4\%$  of the specified value.

## 8.4 Test procedure

### 8.4.1 Provisions concerning the test piece

The test piece shall be gripped in the test equipment in such a way that force is transmitted axially and free of any bending moment along the test piece.

### 8.4.2 Upper force ( $F_{up}$ ) and force range ( $F_r$ )

The upper force ( $F_{up}$ ) and the force range ( $F_r$ ) shall be as given in the relevant product standard.

NOTE  $F_{up}$  and  $F_r$  can be deduced from the maximum stress ( $\sigma_{max}$ ) and the stress range ( $2\sigma_a$ ) given in the relevant product standard as follows:

$$F_{up} = \sigma_{max} \cdot S_n \quad (2)$$

$$F_r = 2\sigma_a \cdot S_n \quad (3)$$

where  $S_n$  is the nominal cross-sectional area of the bar or wire.

### 8.4.3 Stability of force and frequency

The test shall be carried out under conditions of stable upper force ( $F_{up}$ ), force range ( $F_r$ ) and frequency ( $f$ ). There shall be no planned interruptions in the cyclic loading throughout the test. However, it is permissible to continue a test which is accidentally interrupted. Any interruption shall be reported; an interrupted test may be considered as invalid.

### 8.4.4 Counting of force cycles

The number of force cycles shall be counted inclusively from the first full force-range cycle.

### 8.4.5 Frequency

The frequency of force cycles shall be stable during the test and also during the series of tests. It shall be between 1 Hz and 200 Hz.

### 8.4.6 Temperature

The temperature of the test piece shall not exceed 40 °C throughout the test. The temperature of the testing laboratory shall be between 10 °C and 35 °C, unless otherwise specified.

### 8.4.7 Validity of the test

If failure occurs in the grips or within a distance of  $2d$  of the grips or initiates at an exceptional feature, the test may be considered as invalid.

## 9 Chemical analysis

In general, the chemical composition is determined by spectrometric methods.

In case of dispute about analytical methods, the chemical composition shall be determined by an appropriate reference method specified in one of the relevant International Standards.

NOTE The list of the relevant International Standards for the determination of the chemical composition is given in the Bibliography.

## 10 Measurement of the geometrical characteristics of the fabric

### 10.1 Test piece

The test piece shall consist of a sheet of fabric in the as-delivered condition.

### 10.2 Test equipment

The wire or bar spacing, and the length and width of the sheet, shall be measured with an instrument with a resolution of at least 1 mm.

### 10.3 Test procedure

The sheet of fabric shall be laid on a flat surface.

The length and width shall be determined as the gross dimensions of the sheet.

## 11 Test report

The test report shall include at least the following information:

- a) a reference to this part of ISO 15630, i.e. ISO 15630-2:2010;
- b) the identification of the test piece (including the nominal diameter of the bars or wires);
- c) the free length of the test piece;
- d) the type of test and the relevant test results;
- e) the relevant product standard, when applicable;
- f) any complementary useful information concerning the test piece, test equipment and procedure.

## Bibliography

- [1] ISO 437:1982, *Steel and cast iron — Determination of total carbon content — Combustion gravimetric method*
- [2] ISO 439:1994, *Steel and iron — Determination of total silicon content — Gravimetric method*
- [3] ISO 629:1982, *Steel and cast iron — Determination of manganese content — Spectrophotometric method*
- [4] ISO 671:1982, *Steel and cast iron — Determination of sulphur content — Combustion titrimetric method*
- [5] ISO 4829-1:1986, *Steel and cast iron — Determination of total silicon content — Reduced molybdosilicate spectrophotometric method — Part 1: Silicon contents between 0,05 and 1,0 %*
- [6] ISO 4829-2:1988, *Steel and cast iron — Determination of total silicon content — Reduced molybdosilicate spectrophotometric method — Part 2: Silicon contents between 0,01 and 0,05 %*
- [7] ISO/TR 4830-4:1978, *Steel — Determination of low carbon contents — Part 4: Coulometric method after combustion*
- [8] ISO 4934:2003, *Steel and iron — Determination of sulfur content — Gravimetric method*
- [9] ISO 4935:1989, *Steel and iron — Determination of sulfur content — Infrared absorption method after combustion in an induction furnace*
- [10] ISO 4937:1986, *Steel and iron — Determination of chromium content — Potentiometric or visual titration method*
- [11] ISO 4938:1988, *Steel and iron — Determination of nickel content — Gravimetric or titrimetric method*
- [12] ISO 4939:1984, *Steel and cast iron — Determination of nickel content — Dimethylglyoxime spectrophotometric method*
- [13] ISO 4940:1985, *Steel and cast iron — Determination of nickel content — Flame atomic absorption spectrometric method*
- [14] ISO 4941:1994, *Steel and iron — Determination of molybdenum content — Thiocyanate spectrophotometric method*
- [15] ISO 4942:1988, *Steel and iron — Determination of vanadium content — N-BPHA spectrophotometric method*
- [16] ISO 4943:1985, *Steel and cast iron — Determination of copper content — Flame atomic absorption spectrometric method*
- [17] ISO 4945:1977, *Steel — Determination of nitrogen content — Spectrophotometric method*
- [18] ISO 4946:1984, *Steel and cast iron — Determination of copper content — 2,2'-Diquinolyl spectrophotometric method*
- [19] ISO 4947:1986, *Steel and cast iron — Determination of vanadium content — Potentiometric titration method*
- [20] ISO 7438:2005, *Metallic materials — Bend test*
- [21] ISO 9441:1988, *Steel — Determination of niobium content — PAR spectrophotometric method*

- [22] ISO 9556:1989, *Steel and iron — Determination of total carbon content — Infrared absorption method after combustion in an induction furnace*
- [23] ISO 9647:1989, *Steel and iron — Determination of vanadium content — Flame atomic absorption spectrometric method*
- [24] ISO 9658:1990, *Steel — Determination of aluminium content — Flame atomic absorption spectrometric method*
- [25] ISO 10138:1991, *Steel and iron — Determination of chromium content — Flame atomic absorption spectrometric method*
- [26] ISO 10153:1997, *Steel — Determination of boron content — Curcumin spectrophotometric method*
- [27] ISO 10278:1995, *Steel — Determination of manganese content — Inductively coupled plasma atomic emission spectrometric method*
- [28] ISO 10280:1991, *Steel and iron — Determination of titanium content — Diantiprylmethane spectrometric method*
- [29] ISO 10697-1:1992, *Steel — Determination of calcium content by flame atomic absorption spectrometry — Part 1: Determination of acid-soluble calcium content*
- [30] ISO 10697-2:1992, *Steel — Determination of calcium content by flame atomic absorption spectrometry — Part 2: Determination of total calcium content*
- [31] ISO 10698:1994, *Steel — Determination of antimony content — Electrothermal atomic absorption spectrometric method*
- [32] ISO 10700:1994, *Steel and iron — Determination of manganese content — Flame atomic absorption spectrometric method*
- [33] ISO 10701:1994, *Steel and iron — Determination of sulfur content — Methylene blue spectrophotometric method*
- [34] ISO 10702:1993, *Steel and iron — Determination of nitrogen content — Titrimetric method after distillation*
- [35] ISO 10714:1992, *Steel and iron — Determination of phosphorus content — Phosphovanadomolybdate spectrophotometric method*
- [36] ISO/TR 10719:1994, *Steel and iron — Determination of non-combined carbon content — Infrared absorption method after combustion in an induction furnace*
- [37] ISO 10720:1997, *Steel and iron — Determination of nitrogen content — Thermal conductimetric method after fusion in a current of inert gas*
- [38] ISO 11652:1997, *Steel and iron — Determination of cobalt content — Flame atomic absorption spectrometric method*
- [39] ISO 11653:1997, *Steel — Determination of high cobalt content — Potentiometric titration method after separation by ion exchange*
- [40] ISO 13898-1:1997, *Steel and iron — Determination of nickel, copper and cobalt contents — Inductively coupled plasma atomic emission spectrometric method — Part 1: General requirements and sample dissolution*
- [41] ISO 13898-2:1997, *Steel and iron — Determination of nickel, copper and cobalt contents — Inductively coupled plasma atomic emission spectrometric method — Part 2: Determination of nickel content*

- [42] ISO 13898-3:1997, *Steel and iron — Determination of nickel, copper and cobalt contents — Inductively coupled plasma atomic emission spectrometric method — Part 3: Determination of copper content*
- [43] ISO 13898-4:1997, *Steel and iron — Determination of nickel, copper and cobalt contents — Inductively coupled plasma atomic emission spectrometric method — Part 4: Determination of cobalt content*
- [44] ISO/TS 13899-1:2004, *Steel — Determination of Mo, Nb and W contents in alloyed steel — Inductively coupled plasma atomic emission spectrometric method — Part 1: Determination of Mo content*
- [45] ISO 13899-2:2005, *Steel — Determination of Mo, Nb and W contents in alloyed steel — Inductively coupled plasma atomic emission spectrometric method — Part 2: Determination of Nb content*
- [46] ISO/TS 13899-3:2005, *Steel — Determination of Mo, Nb and W contents in alloyed steel — Inductively coupled plasma atomic emission spectrometric method — Part 3: Determination of W content*
- [47] ISO 13900:1997, *Steel — Determination of boron content — Curcumin spectrophotometric method after distillation*
- [48] ISO 13902:1997, *Steel and iron — Determination of high sulfur content — Infrared absorption method after combustion in an induction furnace*
- [49] ISO/TR 15349-1:1998, *Unalloyed steel — Determination of low carbon content — Part 1: Infrared absorption method after combustion in an electric resistance furnace (by peak separation)*
- [50] ISO 15349-2:1999, *Unalloyed steel — Determination of low carbon content — Part 2: Infrared absorption method after combustion in an induction furnace (with preheating)*
- [51] ISO/TR 15349-3:1998, *Unalloyed steel — Determination of low carbon content — Part 3: Infrared absorption method after combustion in an electric resistance furnace (with preheating)*
- [52] ISO 15350:2000, *Steel and iron — Determination of total carbon and sulfur content — Infrared absorption method after combustion in an induction furnace (routine method)*
- [53] ISO 15351:1999, *Steel and iron — Determination of nitrogen content — Thermal conductimetric method after fusion in a current of inert gas (Routine method)*
- [54] ISO 15353:2001, *Steel and iron — Determination of tin content — Flame atomic absorption spectrometric method (extraction as Sn-SCN)*
- [55] ISO 15355:1999, *Steel and iron — Determination of chromium content — Indirect titration method*
- [56] ISO 16918-1:2009, *Steel and iron — Determination of nine elements by the inductively coupled plasma mass spectrometric method — Part 1: Determination of tin, antimony, cerium, lead and bismuth*
- [57] ISO 17053:2005, *Steel and iron — Determination of oxygen — Infrared method after fusion under inert gas*
- [58] ISO 17054:2010, *Routine method for analysis of high alloy steel by X-ray fluorescence spectrometry (XRF) by using a near-by technique*
- [59] ISO/TR 17055:2002, *Steel — Determination of silicon content — Inductively coupled plasma atomic emission spectrometric method*
- [60] ISO 17058:2004, *Steel and iron — Determination of arsenic content — Spectrophotometric method*









# British Standards Institution (BSI)

BSI is the national body responsible for preparing British Standards and other standards-related publications, information and services.

BSI is incorporated by Royal Charter. British Standards and other standardization products are published by BSI Standards Limited.

## About us

We bring together business, industry, government, consumers, innovators and others to shape their combined experience and expertise into standards-based solutions.

The knowledge embodied in our standards has been carefully assembled in a dependable format and refined through our open consultation process. Organizations of all sizes and across all sectors choose standards to help them achieve their goals.

## Information on standards

We can provide you with the knowledge that your organization needs to succeed. Find out more about British Standards by visiting our website at [bsigroup.com/standards](http://bsigroup.com/standards) or contacting our Customer Services team or Knowledge Centre.

## Buying standards

You can buy and download PDF versions of BSI publications, including British and adopted European and international standards, through our website at [bsigroup.com/shop](http://bsigroup.com/shop), where hard copies can also be purchased.

If you need international and foreign standards from other Standards Development Organizations, hard copies can be ordered from our Customer Services team.

## Subscriptions

Our range of subscription services are designed to make using standards easier for you. For further information on our subscription products go to [bsigroup.com/subscriptions](http://bsigroup.com/subscriptions).

With **British Standards Online (BSOL)** you'll have instant access to over 55,000 British and adopted European and international standards from your desktop. It's available 24/7 and is refreshed daily so you'll always be up to date.

You can keep in touch with standards developments and receive substantial discounts on the purchase price of standards, both in single copy and subscription format, by becoming a **BSI Subscribing Member**.

**PLUS** is an updating service exclusive to BSI Subscribing Members. You will automatically receive the latest hard copy of your standards when they're revised or replaced.

To find out more about becoming a BSI Subscribing Member and the benefits of membership, please visit [bsigroup.com/shop](http://bsigroup.com/shop).

With a **Multi-User Network Licence (MUNL)** you are able to host standards publications on your intranet. Licences can cover as few or as many users as you wish. With updates supplied as soon as they're available, you can be sure your documentation is current. For further information, email [bsmusales@bsigroup.com](mailto:bsmusales@bsigroup.com).

## BSI Group Headquarters

389 Chiswick High Road London W4 4AL UK



## Revisions

Our British Standards and other publications are updated by amendment or revision.

We continually improve the quality of our products and services to benefit your business. If you find an inaccuracy or ambiguity within a British Standard or other BSI publication please inform the Knowledge Centre.

## Copyright

All the data, software and documentation set out in all British Standards and other BSI publications are the property of and copyrighted by BSI, or some person or entity that owns copyright in the information used (such as the international standardization bodies) and has formally licensed such information to BSI for commercial publication and use. Except as permitted under the Copyright, Designs and Patents Act 1988 no extract may be reproduced, stored in a retrieval system or transmitted in any form or by any means – electronic, photocopying, recording or otherwise – without prior written permission from BSI. Details and advice can be obtained from the Copyright & Licensing Department.

## Useful Contacts:

### Customer Services

**Tel:** +44 845 086 9001

**Email (orders):** [orders@bsigroup.com](mailto:orders@bsigroup.com)

**Email (enquiries):** [cservices@bsigroup.com](mailto:cservices@bsigroup.com)

### Subscriptions

**Tel:** +44 845 086 9001

**Email:** [subscriptions@bsigroup.com](mailto:subscriptions@bsigroup.com)

### Knowledge Centre

**Tel:** +44 20 8996 7004

**Email:** [knowledgecentre@bsigroup.com](mailto:knowledgecentre@bsigroup.com)

### Copyright & Licensing

**Tel:** +44 20 8996 7070

**Email:** [copyright@bsigroup.com](mailto:copyright@bsigroup.com)

...making excellence a habit.™