

Specification and qualification of welding procedures for metallic materials — Welding procedure test —

**Part 2: Arc welding of aluminium and its
alloys**

The European Standard EN ISO 15614-2:2005 has the status of a
British Standard

ICS 25.160.10

National foreword

This British Standard is the official English language version of EN ISO 15614-2:2005. It is identical with ISO 15614-2:2004. It supersedes BS EN 288-4:1992 which is withdrawn.

The UK participation in its preparation was entrusted to Technical Committee WEE/36, Approval testing of welding procedures and welders, which has the responsibility to:

- aid enquirers to understand the text;
- present to the responsible international/European committee any enquiries on the interpretation, or proposals for change, and keep the UK interests informed;
- monitor related international and European developments and promulgate them in the UK.

A list of organizations represented on this committee can be obtained on request to its secretary.

Cross-references

The British Standards which implement international or European publications referred to in this document may be found in the *BSI Catalogue* under the section entitled “International Standards Correspondence Index”, or by using the “Search” facility of the *BSI Electronic Catalogue* or of British Standards Online.

This publication does not purport to include all the necessary provisions of a contract. Users are responsible for its correct application.

Compliance with a British Standard does not of itself confer immunity from legal obligations.

This British Standard was published under the authority of the Standards Policy and Strategy Committee on 26 April 2005

Summary of pages

This document comprises a front cover, an inside front cover, the EN ISO title page, pages 2 to 35 and a back cover.

The BSI copyright notice displayed in this document indicates when the document was last issued.

Amendments issued since publication

Amd. No.	Date	Comments

© BSI 26 April 2005

ISBN 0 580 45973 X

English version

Specification and qualification of welding procedures for metallic materials - Welding procedure test - Part 2: Arc welding of aluminium and its alloys (ISO 15614-2:2005)

Descriptif et qualification d'un mode opératoire de soudage pour les matériaux métalliques - Epreuve de qualification d'un mode opératoire de soudage - Partie 2: Soudage à l'arc de l'aluminium et de ses alliages (ISO 15614-2:2005)

Anforderung und Anerkennung von Schweißverfahren für metallische Werkstoffe - Schweißverfahrensprüfung - Teil 2: Lichtbogenschweißen von Aluminium und seinen Legierungen (ISO 15614-2:2005)

This European Standard was approved by CEN on 27 May 2004.

CEN members are bound to comply with the CEN/CENELEC Internal Regulations which stipulate the conditions for giving this European Standard the status of a national standard without any alteration. Up-to-date lists and bibliographical references concerning such national standards may be obtained on application to the Central Secretariat or to any CEN member.

This European Standard exists in three official versions (English, French, German). A version in any other language made by translation under the responsibility of a CEN member into its own language and notified to the Central Secretariat has the same status as the official versions.

CEN members are the national standards bodies of Austria, Belgium, Cyprus, Czech Republic, Denmark, Estonia, Finland, France, Germany, Greece, Hungary, Iceland, Ireland, Italy, Latvia, Lithuania, Luxembourg, Malta, Netherlands, Norway, Poland, Portugal, Slovakia, Slovenia, Spain, Sweden, Switzerland and United Kingdom.



EUROPEAN COMMITTEE FOR STANDARDIZATION
COMITÉ EUROPÉEN DE NORMALISATION
EUROPÄISCHES KOMITEE FÜR NORMUNG

Management Centre: rue de Stassart, 36 B-1050 Brussels

Contents

Page

Foreword.....	4
1 Scope	6
2 Normative references	6
3 Terms and definitions	7
4 Preliminary welding procedure specification (pWPS)	7
5 Welding procedure test	7
6 Test piece	8
6.1 General.....	8
6.2 Shape and dimensions of test pieces	8
6.3 Welding of test pieces	12
7 Examination and testing	12
7.1 Extent of testing.....	12
7.2 Location of test specimens	13
7.3 Non-destructive testing.....	17
7.4 Destructive tests	17
7.5 Acceptance levels.....	20
7.6 Re-testing	20
8 Range of qualification	21
8.1 General.....	21
8.2 Related to the manufacturer.....	21
8.3 Related to the parent material	21
8.4 Common to all welding procedures.....	24
8.5 Specific to processes.....	27
9 Welding procedure qualification record (WPQR)	27
Annex A (informative) Welding Procedure Qualification Record form (WPQR)	29
Annex ZA (informative) Relationship between this European Standard and the Essential Requirements of EU Directive 97/23/EC and 87/404/EEC	32
Annex ZB (normative) Normative references to international publications with their relevant European publications.....	33
Bibliography	35

Figures

Figure 1 — Test piece for a butt joint in plate with full penetration	9
Figure 2 — Test piece for a butt joint in pipe with full penetration	10
Figure 3 — Test piece for a T-joint.....	11
Figure 4 — Test piece for a branch connection	12
Figure 5 — Location of test specimens for a butt joint in plate	14
Figure 6 — Location of test specimens for a butt joint in pipe	15
Figure 7 — Location of test specimens for a T-joint.....	16
Figure 8 — Location of test specimens for a branch connection or a fillet weld on pipe	16

Tables

Table 1 — Examination and testing of the test pieces	13
Table 2 — Efficiency for tensile strength of butt joints	18
Table 3 — Examples of maximum calculated former diameter for some elongations and thicknesses	20
Table 4 — Range of qualification for similar and dissimilar metal joints	22
Table 5 — Range of qualification for parent material thickness for plates and pipes	23
Table 6 — Range of qualification for the throat thickness for plates and pipes	24
Table 7 — Range of qualification for pipe and branch connection diameters.....	24
Table 8 — Range of qualification for type of joint	26
Table ZA.1 — Correspondence between this European Standard and Directive 97/23/EC.....	32
Table ZA.2 — Correspondence between this European standard and Directive 87/404/EEC.....	32

Foreword

This document (EN ISO 15614-2:2005) has been prepared by Technical Committee CEN/TC 121 "Welding", the secretariat of which is held by DIN.

This European Standard shall be given the status of a national standard, either by publication of an identical text or by endorsement, at the latest by October 2005, and conflicting national standards shall be withdrawn at the latest by October 2005.

This document supersedes EN 288-4:1992.

EN ISO 15614 consists of the following parts, under the general title *Specification and qualification of welding procedures for metallic materials — Welding procedure test*:

- *Part 1: Part 1: Arc and gas welding of steels and arc welding of nickel and nickel alloys*
- *Part 2: Arc welding of aluminium and its alloys*
- *Part 3: Welding procedure tests for the arc welding of cast iron ¹⁾*
- *Part 4: Finishing welding of aluminium castings ¹⁾*
- *Part 5: Arc welding of titanium, zirconium and their alloys*
- *Part 6: Arc welding of copper and its alloys ¹⁾*
- *Part 7: Overlay welding¹⁾*
- *Part 8: Welding of tubes to tube-plate joints*
- *Part 10: Hyperbaric dry welding ¹⁾*
- *Part 11: Electron and laser beam welding*
- *Part 12: Spot, seam and projection welding*
- *Part 13: Resistance butt and flash welding ¹⁾*

According to the CEN/CENELEC Internal Regulations, the national standards organizations of the following countries are bound to implement this European Standard: Austria, Belgium, Cyprus, Czech Republic, Denmark, Estonia, Finland, France, Germany, Greece, Hungary, Iceland, Ireland, Italy, Latvia, Lithuania, Luxembourg, Malta, Netherlands, Norway, Poland, Portugal, Slovakia, Slovenia, Spain, Sweden, Switzerland and United Kingdom.

¹⁾ To be published.

Introduction

All new welding procedure tests are to be carried out in accordance with this document from the date of this issue.

However, this document does not invalidate previous welding procedure tests made to former standards or specifications or previous issues of this document.

Where additional tests have to be carried out to make the qualification technically equivalent, it is only necessary to do the additional tests on a test piece which should be made in accordance with this document.

Requests for official interpretations of any aspect of this document should be directed to the Secretariat of ISO/TC 44/SC 10 via your national standards body, a complete listing which can be found at www.iso.org.

1 Scope

This document specifies how a preliminary welding procedure specification is qualified by welding procedure tests.

This document is part of a series of standards, details of this series are given in EN ISO 15607:2003, Annex A.

This document defines the conditions for the execution of welding procedure tests and the range of qualification for welding procedures for all practical welding operations within the range of variables listed in Clause 8.

This document applies to the arc welding of wrought and cast aluminium and its alloys. In this document the term aluminium stands for aluminium and for aluminium alloys.

This document does not apply to finishing welding of aluminium castings which is dealt by prEN ISO 15614-4.

Arc welding of aluminium is covered by the following welding processes in accordance with EN ISO 4063:

- 131 : metal inert gas welding (MIG welding);
- 141 : tungsten inert gas welding (TIG welding);
- 15 : plasma arc welding.

NOTE Specific service, material or manufacturing conditions may require more comprehensive testing than is specified by this document (see 7.1).

The principles of this document may be applied to other fusion welding processes.

2 Normative references

The following referenced documents are indispensable for the application of this document. For dated references, only the edition cited applies. For undated references, the latest edition of the referenced document (including any amendments) applies.

EN 515, *Aluminium and aluminium alloys — Wrought products — Temper designations*.

EN 571-1, *Non destructive testing — Penetrant testing — Part 1: General principles*.

EN 1714, *Non-destructive examination of welds — Ultrasonic examination of welded joints*.

EN ISO 6947, *Welds — Working positions — Definitions of angles of slope and rotation (ISO 6947:1993)*.

EN ISO 9606-2, *Qualification test of welders — Fusion welding — Part 2: Aluminium and aluminium alloys (ISO 9606-2:2004)*.

EN ISO 15607:2003, *Specification and qualification of welding procedures for metallic materials — General rules (ISO 15607:2003)*.

EN ISO 15609-1, *Specification and qualification of welding procedures for metallic materials — Welding procedure specification — Part 1: Arc welding (ISO 15609-1:2004)*.

EN ISO 15613, *Specification and qualification of welding procedures for metallic materials — Qualification based on pre-production welding test (ISO 15613:2004)*.

ISO 4136, *Destructive tests on welds in metallic materials — Transverse tensile test*.

ISO 5173, *Destructive tests on welds in metallic materials — Bend tests*.

ISO 9017, *Destructive tests on welds in metallic materials — Fracture test.*

ISO 10042, *Arc-welded joints in aluminium and its weldable alloys — Guidance on quality levels for imperfections.*

ISO 14175, *Welding consumables — Shielding gases for arc welding and cutting.*

ISO 14732, *Welding personnel — Approval testing of welding operators for fusion welding and resistance weld setters for fully mechanized and automatic welding of metallic materials.*

ISO 17635, *Non-destructive testing of welds — General rules for fusion welds in metallic materials .*

ISO 17636, *Non-destructive testing of welds — Radiographic testing of fusion-welded joints.*

ISO 17637, *Non-destructive testing of welds — Visual testing of fusion-welded joints*

ISO 17639, *Destructive tests on welds in metallic materials — Macroscopic and microscopic examination of welds.*

ISO/TR 15608, *Welding — Guidelines for a metallic material grouping system.*

ISO/TR 17671-1, *Welding — Recommendations for welding of metallic materials — Part 1: General guidance for arc welding.*

ISO/TR 17671-4, *Welding — Recommendations for welding of metallic materials — Part 4: Arc welding of aluminium and aluminium alloys.*

3 Terms and definitions

For the purposes of this document, the terms and definitions given in EN ISO 15607:2003 and the following apply.

3.1

finishing welding

welding carried out during production in order to remove casting defects and core openings to ensure the agreed quality of castings

4 Preliminary welding procedure specification (pWPS)

The preliminary welding procedure specification shall be prepared in accordance with EN ISO 15609-1. It shall specify the tolerance for all the relevant parameters.

Guidance for the welding of aluminium is given in ISO/TR 17671-1 and ISO/TR 17671-4.

5 Welding procedure test

The welding and testing of test pieces shall be in accordance with Clauses 6 and 7.

The welder or welding operator who undertakes the welding procedure test satisfactorily in accordance with this document is qualified for the appropriate range of qualification in accordance with EN ISO 9606-2 or ISO 14732, providing that the relevant testing requirements are met.

6 Test piece

6.1 General

The welded joint to which the welding procedure will relate in production shall be represented by making a standardized test piece or pieces, as specified in 6.2. Where the production/joint geometry requirements do not represent the standardized test pieces as shown in this document, the use of EN ISO 15613 shall be required.

6.2 Shape and dimensions of test pieces

6.2.1 General

The length or number of test pieces shall be sufficient to allow all required tests to be carried out.

Additional test pieces, or longer test pieces than the minimum size, may be prepared in order to allow for extra and or for re-testing specimens (see 7.6).

For all test pieces except branch connections (see Figure 4) and T-joints (see Figure 3) the material thickness, t , shall be the same for both plates/pipes to be welded. If required by the application standard, the direction of working, e.g. for extrusion, shall be marked on the test piece.

The material thickness and/or pipe outside diameter of the test pieces shall be selected in accordance with 8.3.2.1 to 8.3.2.4.

The shape and minimum dimensions of the test piece shall be as follows:

6.2.2 Butt joint in plate with full penetration

The test piece shall be prepared in accordance with Figure 1.

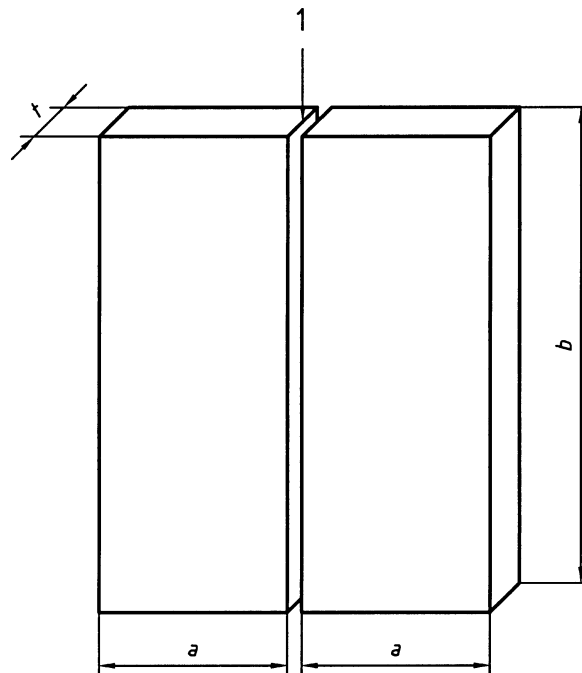

Key

- 1 Joint preparation and fit-up as detailed in the preliminary Welding Procedure Specification (pWPS)
- a* Minimum value 150 mm (transverse bend test specimens may require a larger *a*, see 7.4)
- b* Minimum value 300 mm
- t* Material thickness

Figure 1 — Test piece for a butt joint in plate with full penetration

6.2.3 Butt joint in pipe with full penetration

The test piece shall be prepared in accordance with Figure 2.

NOTE The word "pipe" alone or in combination is used to mean "pipe", "tube" or "hollow section".

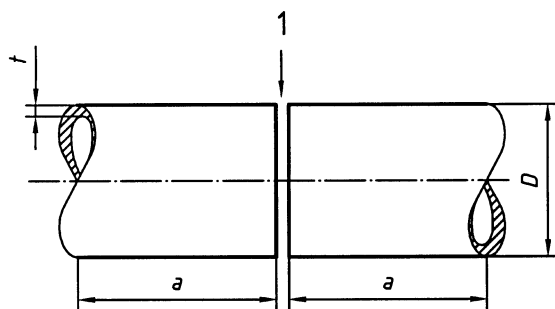

Key

- 1 Joint preparation and fit-up as detailed in the preliminary Welding Procedure Specification (pWPS)
- a* Minimum value 150 mm
- D* Outside pipe diameter
- t* Material thickness

Figure 2 — Test piece for a butt joint in pipe with full penetration

6.2.4 T-joint

The test piece shall be prepared in accordance with Figure 3.

This may be used for fully penetrated butt welds or fillet welds.

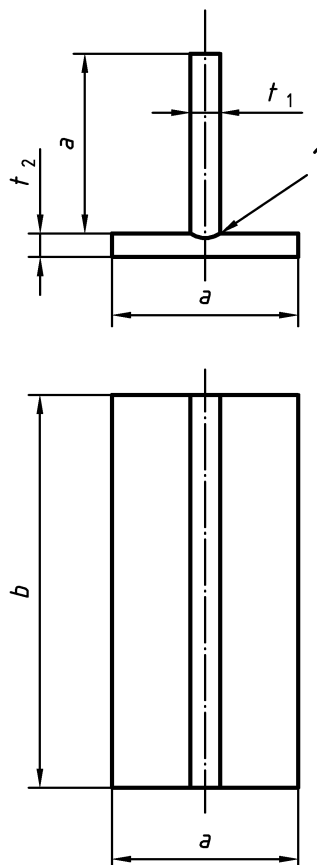

Key

- 1 Weld one side or both sides and fit-up as detailed in the preliminary Welding Procedure Specification (pWPS)
- a* Minimum value 150 mm
- b* Minimum value 300 mm
- t* Material thickness

Figure 3 — Test piece for a T-joint

6.2.5 Branch connection and fillet weld on pipe

The test piece shall be prepared in accordance with Figure 4. The branch angle α is the minimum to be used in production.

This may be used for fully penetrated joints (set-on or set-in or set-through joint) and for T-joints.

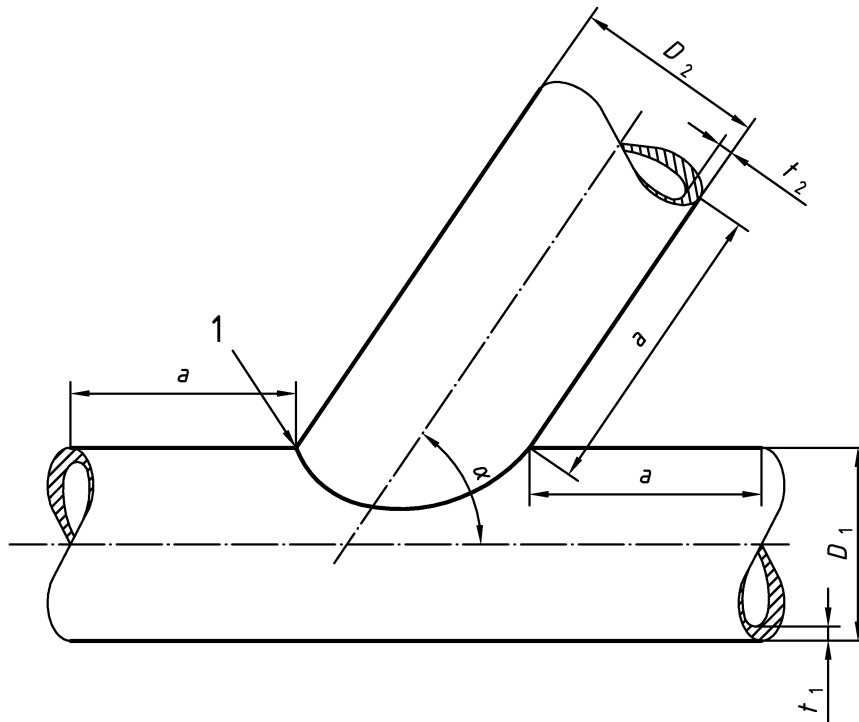

Key

- 1 Joint preparation and fit-up as detailed in the preliminary Welding Procedure Specification (pWPS)
- a* Minimum value 150 mm
- D_1 Outside diameter of the main pipe
- D_2 Outside diameter of the branch pipe
- t_1 Main pipe material thickness
- t_2 Branch pipe material thickness
- α Branch angle

Figure 4 — Test piece for a branch connection

6.3 Welding of test pieces

Preparation and welding of test pieces shall be carried out in accordance with the pWPS and under the conditions of welding in production which they shall represent. Welding positions and limitations for the angle of slope and rotation of the test piece shall be in accordance with EN ISO 6947. If tack welds are to be fused into the production joint, they shall be included in the test piece.

Welding and testing of the test pieces shall be witnessed by an examiner or examining body.

7 Examination and testing

7.1 Extent of testing

Testing includes both non-destructive testing (NDT) and destructive testing, which shall be in accordance with the requirements of Table 1.

An application standard may specify additional tests, e.g :

- longitudinal weld tensile test;
- weld metal bend test or special weld metal bend test to measure elongation;
- tensile test for the determination of the 0,2 % proof strength and/or elongation;
- chemical analysis;
- cruciform test.

NOTE Specific service, material or manufacturing conditions may require more comprehensive testing than is specified by this document in order to gain more information and to avoid repeating the welding procedure test at a later date just to obtain additional test data.

Table 1 — Examination and testing of the test pieces

Test piece	Type of test	Extent of testing	Footnote
Butt joint with full penetration (Figures 1 and 2)	Visual	100 %	—
	Radiographic or ultrasonic	100 %	—
	Penetrant testing	100 %	—
	Transverse tensile test	2 test specimens	—
	Transverse bend test or fracture test for cast materials or wrought/cast combinations	2 root and 2 face test specimens	a
	Macroscopic examination	1 test specimen	—
	Microscopic examination	1 test specimen	b
T- joint with full penetration - Figure 3 Branch connection ^c with full penetration Figure 4	Visual	100 %	—
	Penetrant testing	100 %	—
	Macroscopic examination	4 test specimens	d
	Microscopic examination	1 test specimen	b
Fillet welds ^c Figure 3 and Figure 4	Visual	100 %	—
	Penetrant testing	100 %	—
	Macroscopic examination	2 test specimens	—
	Microscopic examination	1 test specimen	b
<p>^a Two root and two face bend test specimens may be preferably substituted by four side bend test specimens for $t \geq 12$ mm.</p> <p>^b Only for material group 23 and all casting alloys.</p> <p>^c Tests as detailed do not provide information on the mechanical properties of the joint. Where these properties are relevant to the application an additional qualification shall also be held e.g. a butt joint qualification.</p> <p>^d For test specimens according to Figure 3, only two macro test specimens.</p>			

7.2 Location of test specimens

Test specimens shall be taken in accordance with Figures 5, 6, 7 and 8.

Test specimens shall be taken after all non-destructive testing (NDT) has been carried out and which has passed the relevant inspection criteria for the NDT method(s) used.

It is acceptable to take the test specimens from locations avoiding areas which have imperfections within the acceptance limits for the NDT method(s) used.

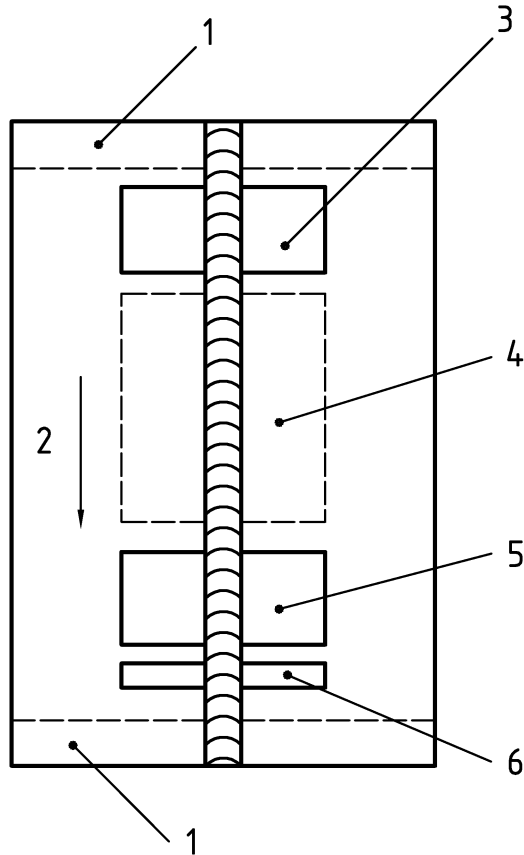

Key

- 1 Discard 25 mm
- 2 Welding direction
- 3 Area for: — 1 tensile test specimen
— bend test specimens or fracture test specimens
- 4 Area for: — additional test specimens if required
- 5 Area for: — 1 tensile test specimen
— bend test specimens or fracture test specimens
- 6 Area for: — 1 macro test specimen
— 1 micro test specimen

NOTE Not to scale.

Figure 5 — Location of test specimens for a butt joint in plate

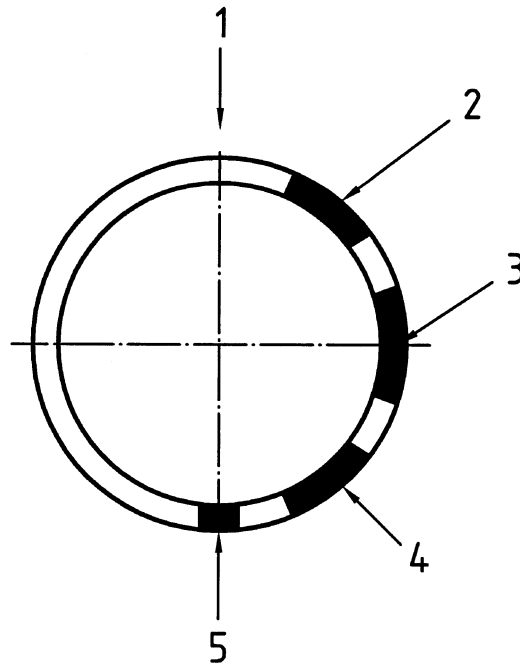

Key

- 1 Top of fixed pipe
- 2 Area for: — 1 tensile test specimen
— bend test specimens or fracture test specimens
- 3 Area for: — additional test specimens if required
- 4 Area for: — 1 tensile test specimen
— bend test specimens or fracture test specimens
- 5 Area for: — 1 macro test specimen
— 1 micro test specimen

NOTE Not to scale.

Figure 6 — Location of test specimens for a butt joint in pipe

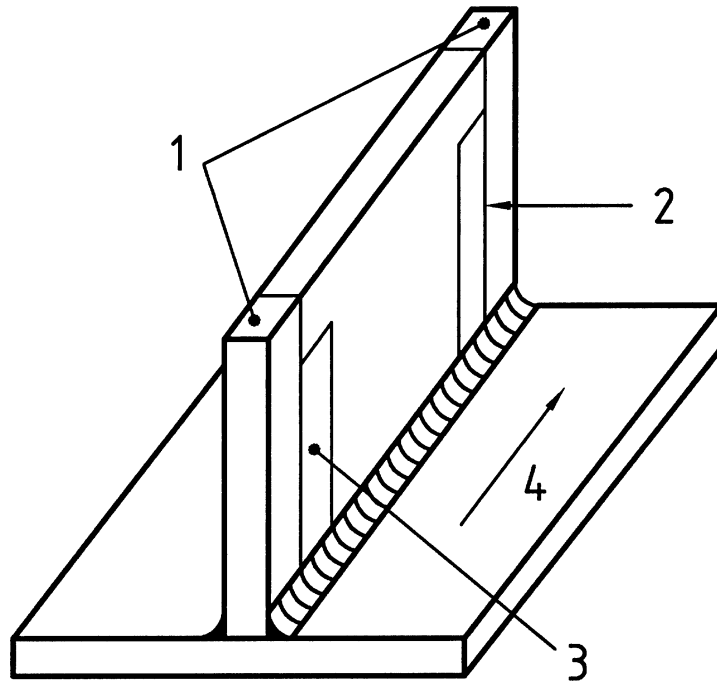

Key

- 1 Discard 25 mm
- 2 Micro and macro test specimens
- 3 1 macro test specimen
- 4 Welding direction

Figure 7 — Location of test specimens for a T-joint

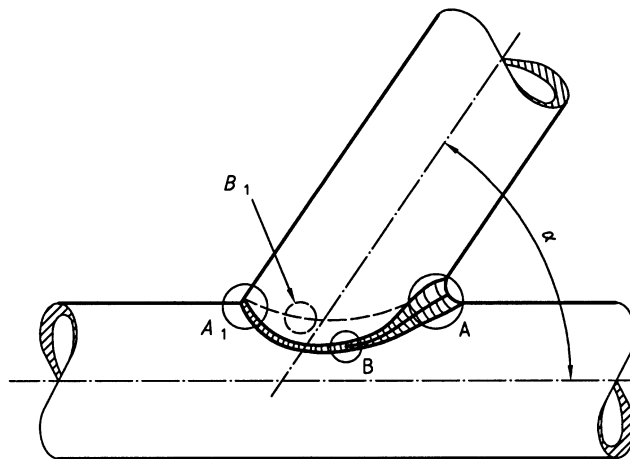

Key

- α Branch angle
- Macro test specimens to be taken in positions A and A₁ and B and B₁
- Micro test specimen to be taken in position A

Figure 8 — Location of test specimens for a branch connection or a fillet weld on pipe

7.3 Non-destructive testing

All non-destructive testing in accordance with 7.1 and Table 1 shall be carried out on the test pieces prior to cutting of the test specimens.

Depending upon joint geometry, materials and the requirements for work, the NDT shall be carried out as required in Table 1 in accordance with ISO 17637 (visual examination), ISO 17636 (radiographic examination), EN 1714 (ultrasonic examination), EN 571-1 (penetrant testing).

7.4 Destructive tests

7.4.1 General

The extent of testing shall be as required by Table 1.

7.4.2 Transverse tensile test

Test specimens and testing for transverse tensile testing for butt joints shall be in accordance with ISO 4136.

For pipes > 50 mm outside diameter, the excess weld metal shall be removed on both faces to give the test specimen a thickness equal to the wall thickness of the pipe.

For pipes ≤ 50 mm outside diameter, and when full section small diameter pipes are used, the excess weld metal may be left undressed on the inside surface of the pipe.

The tensile strength of the test specimen shall not be less than the corresponding specified minimum value for the parent material required in the relevant standard, in the "O" condition for groups 21 and 22, see Table 2.

The tensile strength $R_m(w)$ of the welded test specimen in the as post-welded condition shall satisfy the following requirement:

$$R_m(w) = R_m(pm) \times T$$

where

$R_m(w)$ is the tensile strength of the welded test specimen in the as post-welded condition;

$R_m(pm)$ is the specified minimum tensile strength of the parent material required in the relevant standard;

T is the joint efficiency factor.

For combinations between different alloys the lowest individual $R_m(w)$ value shall be achieved.

Table 2 — Efficiency for tensile strength of butt joints

Material group or sub-group (see ISO/TR 15608)	Temper condition of parent material before welding ^{a b}	Post weld condition ^c	$T = \frac{R_m(w)}{R_m(pm)}$
21	All temper conditions	As welded	1,0 ^d
22	All temper conditions	As welded	1,0 ^d
23.1	T4	Natural ageing	0,7
	T4	Artificial ageing	0,7 ^{e f}
	T5 and T6	Natural ageing	0,6
	T5 and T6	Artificial ageing	0,7 ^f
23.2	T4	Natural ageing	0,95
	T4	Artificial ageing	0,75 ^{e f}
	T6	Natural ageing	0,75
	T6	Artificial ageing	0,75 ^f
Other alloys	All temper conditions	— ^g	— ^g

^a See EN 515.
^b For parent material in other tempers not shown in the Table, $R_m(w)$ shall be in accordance with the design specification.
^c Ageing conditions shall be in accordance with the design specification.
^d $R_m(pm)$ is based on the specified minimum tensile strength of the "O" condition, irrespective of the actual parent material temper used for the test.
^e When the test pieces are artificially aged after welding and prior to testing, the efficiency factor T applies to the T6 parent material condition.
^f Higher properties may be achieved if post-weld full heat treatment is applied. $R_m(w)$ shall be in accordance with the design specification.
^g The post weld ageing conditions and $R_m(w)$ shall be in accordance with the design specification.

7.4.3 Bend test

Test specimens for bend testing for butt joints shall be in accordance with ISO 5173.

For all groups the bend angle shall be 180° using the calculated former diameter based upon material elongation as follows:

— For elongation > 5 %

$$d = \frac{100 \times t_s}{A} - t_s$$

where

- d is the maximum former diameter
- t_s is the thickness of the bend test specimen (this includes side bends)
- A is the minimum tensile elongation required by the manufacturer material specification (for combination between different alloys the lowest individual value shall be used).

Table 3 gives examples of maximum calculated former diameter for some elongations and thicknesses.

Values shall be rounded down to aid those performing tests.

A smaller former diameter may be used at the discretion of the testing facility.

— For elongation $\leq 5\%$ annealing shall be carried out before testing. The former diameter shall be calculated with the elongation given by the specified "O" temper conditions.

During testing, the test specimens shall not reveal any one single flaw > 3 mm in any direction. Flaws appearing at the corners of a test specimen during testing shall be ignored in the evaluation.

Table 3 — Examples of maximum calculated former diameter for some elongations and thicknesses

Thickness of the bend test specimen t_s mm	Elongation A %							
	8	10	12	15	17	20	25	35
	Maximum calculated former diameter d mm							
4	46	36	29	23	20	16	12	7
6	69	54	44	34	29	24	18	11
8	92	72	59	45	39	32	24	15
10	115	90	73	57	49	40	30	19
12	138	108	88	68	59	48	36	22
15	172	135	110	85	73	60	45	28
20	230	180	147	113	98	80	60	37
25	288	225	183	142	122	100	75	46
30	345	270	220	170	146	120	90	56
35	402	315	257	198	171	140	105	65
40	460	360	293	227	195	160	120	74

7.4.4 Fracture test

Test specimens and testing for fracture test for butt joints shall be in accordance with ISO 9017.

7.4.5 Macroscopic/Microscopic examination

The test specimen shall be prepared and examined in accordance with ISO 17639 on one side to clearly reveal the fusion line, the HAZ and the build up of the runs.

The macroscopic examination shall include unaffected parent material.

The acceptance levels stated in 7.5 shall apply.

Care should be taken when etching certain alloys to avoid producing crack like indications.

7.5 Acceptance levels

A welding procedure is qualified if the imperfections in the test piece are within the specified limits of level B in EN 30042 except for imperfection types as follows: excess weld metal, excess convexity, excess throat thickness and excessive penetration, for which level C shall apply.

The correlation between the quality levels of ISO 10042 and the acceptance levels of the different NDT techniques are given in ISO 17635.

7.6 Re-testing

If the test piece fails to comply with any of the requirements for visual examination or NDT specified in 7.5, one further test piece shall be welded and subjected to the same examination. If this additional test piece does not comply with the requirements, the welding procedure test has failed.

If any test specimens fail to comply with the requirements for destructive testing in accordance with 7.4 but only due to weld imperfections, two further test specimens shall be tested for each one that failed. The additional test specimens can be taken from the same test piece, if there is sufficient material, or from a new test piece.

If a tensile test specimen fails to meet the requirements of 7.4.2, two further test specimens shall be obtained for each one that failed. Both shall satisfy the requirements of 7.4.2.

Each additional test specimen shall be subjected to the same tests as the initial test specimen that failed. If either of the additional test specimens does not comply with the requirements, the welding procedure test has failed.

8 Range of qualification

8.1 General

Each of the conditions given in Clause 8 shall be met in order to comply with this document.

Changes outside of the ranges specified shall require a new welding procedure test.

8.2 Related to the manufacturer

A qualification of a pWPS by a welding procedure test according to this document obtained by a manufacturer is valid for welding in workshops or sites under the same technical and quality control of the manufacturer.

Welding is under the same technical and quality control when the manufacturer who performed the welding procedure test retains complete responsibility for all welding carried out to it.

8.3 Related to the parent material

8.3.1 Parent material grouping

In order to minimize the number of welding procedure tests, aluminium and aluminium alloys are grouped according to ISO/TR 15608.

The grouping is made in respect of the intentional added elements but not for trace impurities.

Separate welding procedure qualifications are required for each parent material or parent material combinations not covered by the grouping system.

Permanent backing material shall be considered as a parent material within the qualification (sub-)group.

The range of qualification for similar and dissimilar joints is given in Table 4.

Any dissimilar metal joint not covered by Table 4 shall require a specific test with no range of qualification for other parent materials.

For verification of mechanical properties additional test pieces may be required on similar metal joints.

Any qualification obtained for a dissimilar metal joint gives qualification for each sub-group of parent material welded with the same type of filler metal.

Table 4 — Range of qualification for similar and dissimilar metal joints

Material (sub-) group of the test piece	Similar joint range (sub-) groups	Dissimilar joint range (sub-) groups
21 to 21	21 to 21	Not applicable
22.1 to 22.1	22.1 to 22.1	22.1 to 22.2
	22.2 to 22.2	
22.2 to 22.2	22.2 to 22.2	22.1 to 22.2
	22.1 to 22.1	
22.3 to 22.3	22.3 to 22.3	Combinations between 22.1, 22.2, 22.3 and 22.4
	22.1 to 22.1	
	22.2 to 22.2	
	22.4 to 22.4	
22.4 to 22.4	22.4 to 22.4	Combinations between 22.1, 22.2, 22.3 and 22.4
	22.1 to 22.1	
	22.2 to 22.2	
	22.3 to 22.3	
23.1 to 23.1	23.1 to 23.1	Combinations between 22.1, 22.2 ^a , 22.3 ^a and 22.4 ^a
	22.1 to 22.1	
	22.2 to 22.2 ^a	
	22.3 to 22.3 ^a	
	22.4 to 22.4 ^a	
23.2 to 23.2	23.2 to 23.2	23.2 to 23.1
	23.1 to 23.1	Combinations between 22.1, 22.2 ^a , 22.3 ^a and 22.4 ^a
	22.1 to 22.1	
	22.2 to 22.2 ^a	
	22.3 to 22.3 ^a	
	22.4 to 22.4 ^a	
24.1 to 24.1	24.1 to 24.1	Not applicable
24.2 to 24.2	24.2 to 24.2	24.2 to 24.1 and 24.2 to 23.1 ^b
	24.1 to 24.1	
	23.1 to 23.1 ^b	
25 to 25	25 to 25	25 to 24.1
	24.1 to 24.1	25 to 24.2
	24.2 to 24.2	
26 to 26	26 to 26	26 to any of 24.1 ^c , 24.2 ^c or 25 ^c
	24.1 to 24.1 ^c	
	24.2 to 24.2 ^c	
	25 to 25 ^c	
NOTE The qualification is valid provided the same filler material is used.		
^a Provided Al-Mg filler material is used. ^b Provided Al-Si filler material is used. ^c Only for castings.		

8.3.2 Parent material thickness and pipe diameter

8.3.2.1 General

Nominal thickness t shall have the following meanings:

a) For a butt joint:

the parent material thickness which, for joints between dissimilar thicknesses, is that of the thinner material.

b) For a fillet weld:

the parent material thickness qualified for joints between different thicknesses is that of the thinner material. For each thickness range qualified as in Table 5 there is also an associated range of qualified fillet weld throat thicknesses as given in 8.3.2.3.

c) For a set-on branch connection:

the thickness of the branch pipe.

d) For a set-in or set-through branch connection:

the thickness of the main pipe.

8.3.2.2 Range of qualification for parent material thickness

The qualification of a welding procedure test on thickness t for single and multi-run processes shall include qualification for thickness ranges given in Table 5.

For multi-process procedures, the deposited weld metal thickness for each welding process may be used as a basis for the range of qualification for the individual welding process.

For automatic single run processes the depth of penetration is the maximum depth qualified.

Table 5 — Range of qualification for parent material thickness for plates and pipes

Dimensions in millimetres

Thickness of the test piece t	Range of qualification
$t \leq 3$	0,5 t to 2 t
$3 < t \leq 20$	3 to 2 t
$t > 20$	$\geq 0,8 t$

8.3.2.3 Range of qualification for throat thickness of fillet welds

In addition to the requirements of Table 5, the range of qualification of the throat thickness a is given in Table 6.

Table 6 — Range of qualification for the throat thickness for plates and pipes

Dimensions in millimetres

Throat thickness of the test piece a	Range of qualification
$a < 10$	0,75 a to 1,5 a
$a \geq 10$	$\geq 7,5$

Where a fillet weld is qualified by means of a butt weld test, the throat thickness range qualified shall be based on the thickness of the deposited weld metal.

Where the majority of production work is fillet welding, an additional fillet weld test may be required.

8.3.2.4 Range of qualification for the diameter of pipes and branch connections

The qualification of a welding procedure test on diameter D shall include qualification for diameters in the following ranges given in Table 7.

Qualification given for plates also covers pipes when the outside diameter is > 500 mm or when the diameter is > 150 mm welded in the welding position PA or PC (rotated position).

Table 7 — Range of qualification for pipe and branch connection diameters

Dimensions in millimetres

Diameter of the test piece D^a	Range of qualification
$D \leq 25$	0,5 D to 2 D
$D > 25$	$\geq 0,5 D$ (25 mm min)
NOTE For structural hollow section, D is the dimension of the smaller side.	
^a D is the outside diameter of the pipe or outside diameter of the branch pipe.	

8.3.3 Angle of branch connection

A welding procedure test carried out on a branch connection with angle α shall qualify all branch angles α_1 in the range of $\alpha \leq \alpha_1 \leq 90^\circ$.

8.4 Common to all welding procedures

8.4.1 Welding process

Each degree of mechanisation shall be qualified independently (manual, partly mechanised, fully mechanised and automatic).

The qualification is only valid for the welding process(es) used in the welding procedure test.

For multi-process procedures the welding procedure qualification may be carried out with separate welding procedure tests for each welding process. It is also possible to make the welding procedure test as a multi-

process procedure test. The qualification of such a test is only valid for the process sequence carried out during the multi-process procedure test.

NOTE It is not allowed to use a multi-process procedure test to qualify any single process unless the testing carried out on the welding process conforms to this document.

8.4.2 Welding positions

Welding of a test in any one position (pipe or plate) qualifies for welding in all positions (pipe or plate) except for PG and J-L045 where a separate welding procedure test is required.

8.4.3 Type of joint

The range of qualification for the types of welded joints used in the welding procedure test is given in Table 8. In this table the range of qualification is indicated in the same horizontal line.

It is not permitted to change a multi-run deposit into a single run (or single run on each side) or vice versa for a given welding process.

Table 8 — Range of qualification for type of joint

Type of joint in the test piece used in the welding procedure test			Range of qualification								
			Butt joint on plate ^b				Butt joint on pipe		Branch connections		Fillet welds on pipe and plate
			Welded from one side		Welded from both sides		Welded from one side		Welded from one side	Welded from both sides	
			with backing	no backing	with gouging	no gouging	with backing	no backing	—	—	—
Butt joint on plate ^b	Welded from one side	with backing	X	—	X	—	X ^a	—	—	X ^a	X
		no backing	X	X	X	X	X ^a	X ^a	X ^a	X ^a	X
	Welded from both sides	with gouging	X	—	X	—	X ^a	—	—	X ^a	X
		no gouging	X	—	X	X	—	—	—	X ^a	X
Butt joint on pipe	Welded from one side	with backing	X	—	X	—	X	—	—	X	X
		no backing	X	X	X	X	X	X	X	X	X
Branch connections	Welded from one side	—	—	—	—	—	—	—	X	X	X
	Welded from both sides	—	—	—	—	—	—	—	—	X	X
Fillet welds on plate and pipe	—	—	—	—	—	—	—	—	—	—	X

Key :
X indicates those welding types of joint covered by the WPS.
— indicates those welding types of joint not covered by the WPS.
^a Plate qualifies pipe with $D > 500$ mm.
^b Butt joints on plate qualify T-joints.

8.4.4 Filler metal, designation

The range of qualification for filler metals covers other filler metals within the same type defined in ISO/TR 17671-4.

8.4.5 Type of current

The qualification is given for the type of current (alternating current (AC), direct current (DC), pulsed current) and polarity used in the welding procedure test.

8.4.6 Heat Input

The requirements of this clause only apply when the control of heat input is specified.

The upper limit of heat input qualified is 25 % greater than that used in welding the test piece.

The lower limit of heat input qualified is 25 % lower than that used in welding the test piece.

Heat input is calculated in accordance with ISO/TR 17671-1.

8.4.7 Preheat temperature

When preheating is required, the lower limit of qualification is the nominal preheat temperature applied at the start of the welding procedure test.

8.4.8 Interpass temperature

The upper limit of qualification is the highest interpass temperature reached in the welding procedure test.

8.4.9 Post-weld heat treatment or ageing

Post weld heat treatment e.g. artificial ageing, natural ageing shall be specified in the pWPS in accordance with EN 515. Addition or deletion of post-weld heat treatment or ageing is not permitted.

The temperature range and the ageing conditions specified in the pWPS is the range qualified.

8.5 Specific to processes

8.5.1 Process 131

8.5.1.1 The qualification given to the shielding gas is restricted to the symbol according to ISO 14175. Shielding gases not covered by ISO 14175 are restricted to the nominal composition used in the test.

8.5.1.2 The qualification given is restricted to the wire system used in the welding procedure test (e.g. single-wire or multiple-wire system).

8.5.2 Process 141

The qualification given to shielding gas and backing gas is restricted to the symbol according to ISO 14175 used in the welding procedure test. Shielding gases not covered by ISO 14175 are restricted to the nominal composition used in the test.

8.5.3 Process 15

8.5.3.1 The qualification given is restricted to the nominal composition of the plasma gas used in the welding procedure test.

8.5.3.2 The qualification given to the shielding gas and backing gas is restricted to the designation according to ISO 14175 used in the welding procedure test. Shielding gases not covered by ISO 14175 are restricted to the nominal composition used in the test.

9 Welding procedure qualification record (WPQR)

The welding procedure qualification record (WPQR) is a statement of the results of assessing each test piece including re-tests. The relevant items listed for the WPS in EN ISO 15609-1 shall be included, together with

details of any features that would be rejectable by the requirements of Clause 7. If no rejectable features or unacceptable test results are found, a WPQR detailing the welding procedure test piece results is qualified and shall be signed and dated by the examiner or examining body.

A WPQR format shall be used to record details for the welding procedure and the test results, in order to facilitate uniform presentation and assessment of the data.

An example of the WPQR format is shown in Annex A.

Annex A (informative)

Welding Procedure Qualification Record form (WPQR)

Welding procedure qualification - Test certificate

Manufacturer's WPQR No.: Examiner or examining body

Manufacturer: Reference No.:

Address:

Code/ testing standard:

Date of welding:

Range of qualification

Welding process(es):

Type of joint and weld:

Parent material group (s) and sub-group(s):

Parent material thickness (mm):

Throat thickness (mm):

Single run/multi run:

Outside pipe diameter (mm):

Filler metal type:

Designation of shielding gas:

Designation of backing gas:

Type of welding current and polarity:

Heat input:

Welding positions:

Preheat temperature:

Interpass temperature:

Post-weld heat treatment and/or ageing:

Other information:

Certified that test welds prepared, welded and tested satisfactorily in accordance with the requirements of the code/testing standard indicated above.

Location	Date of issue	Examiner or examining body
		Name, date and signature

Record of weld test

Location: Examiner or examining body:
 Manufacturer's pWPS No.: Method of preparation and cleaning:
 Manufacturer's WPQR No.: Parent material specification:
 Manufacturer: Material thickness (mm):
 Welder's name: Outside pipe diameter (mm):
 Welding process: Welding position:
 Joint type and weld:
 Weld preparation details (sketch)* :

Joint design	Welding sequences

Welding details

Run	Welding process	Size of filler metal	Current A	Voltage V	Type of current/Polarity	Wire feed speed	Travel speed*	Heat input

Filler metal designation: Other information * e.g.:
 Any special baking or drying: weaving (maximum width of run):
 Gas : - Shielding: Oscillation (amplitude, frequency, dwell time):
 - Backing: Pulse welding details:
 Gas flow rate- Shielding: Distance contact tube/ workpiece:
 - Backing: Plasma welding details:
 Tungsten electrode type/size: Torch angle:
 Details of back gouging/backing:
 Preheat temperature:
 Interpass temperature:
 Post-weld heat treatment and/or ageing
 (time, temperature, method,
 heating and cooling rates):

.....
 Manufacturer
 Name, date and signature

.....
 Examiner or examining body
 Name, date and signature

Test results

* if required.

Manufacturer's WPQR No.:

Examiner or examining body

Reference No.:

Non-destructive testing

Type	Acceptable	Non-acceptable	Report No.
Visual examination			
Penetrant testing			
Radiographic testing			
Ultrasonic testing			

Metallographic examinations

Type	Acceptable	Non-acceptable	Report No.
Macro			
Micro			

Destructive tests

Tensile tests Required Yes No

Test temperature :

Type/No.	R_e N/mm ²	R_m N/mm ²	A % on	Z %	Fracture location	Remarks
Requirement						
1						
2						

Acceptable Yes No

Bend tests Required: Yes No

Type/No.	Bend side	Former diameter <i>d</i>	Result

Acceptable Yes No

Other tests*:

Remarks:

Tests carried out in accordance with the requirements of:

Laboratory report reference No.:

Test results were acceptable/not acceptable (delete as appropriate)

Tests carried out in the presence of:

.....
Examiner or examining body
Name date and signature

* if required.

Annex ZA (informative)

Relationship between this European Standard and the Essential Requirements of EU Directive 97/23/EC and 87/404/EEC

This European Standard has been prepared under a mandate given to CEN by the European Commission and the European Free Trade Association to provide a means of conforming to Essential Requirements of the New Approach Directive 97/23/EC and 87/404/EEC.

Once this standard is cited in the Official Journal of the European Communities under that Directive and has been implemented as a national standard in at least one Member State, compliance with the clauses of this standard given in the Tables ZA.1 and ZA.2 confers, within the limits of the scope of this standard, a presumption of conformity with the corresponding Essential Requirements of that Directive and associated EFTA regulations.

Table ZA.1 — Correspondence between this European Standard and Directive 97/23/EC

Clauses/sub-clauses of this European Standard	Essential requirements (ERs) of Directive 97/23/EC	Qualifying remarks/Notes
Clauses 4, 5, 6, 7, 8, 9	Annex I, 3.1.2	Permanent joining

Table ZA.2 — Correspondence between this European standard and Directive 87/404/EEC

Clauses/sub-clauses of this European Standard	Essential requirements (ERs) of Directive 87/404/EEC	Comments/Notes
Clause 9	Annex II, 3.c.iii	Welding Procedure Qualification Record

WARNING Other requirements and other EU Directives may be applicable to the product(s) falling within the scope of this standard.

Annex ZB (normative)

Normative references to international publications with their relevant European publications

This European Standard incorporates by dated or undated reference, provisions from other publications. These normative references are cited at the appropriate places in the text and the publications are listed hereafter. For dated references, subsequent amendments to or revisions of any of these publications apply to this European Standard only when incorporated in it by amendment or revision. For undated references the latest edition of the publication referred to applies.

NOTE Where an International Publication has been modified by common modifications, indicated by (mod.), the relevant EN/HD applies.

<u>Publication</u>	<u>Year</u>	<u>Title</u>	<u>EN</u>	<u>Year</u>
ISO 14175		Welding consumables — Shielding gases for arc welding and cutting	EN 439	
ISO 4136		Destructive tests on welds in metallic materials — Transverse tensile test	EN 895	
ISO 5173		Destructive tests on welds in metallic materials — Bend tests	EN 910	
ISO 17637		Non-destructive testing of welds — Visual testing of fusion-welded joints	EN 970	
ISO/TR 17671-1		Welding — Recommendations for welding of metallic materials — Part 1: General guidance for arc welding.	EN 1011-1	
ISO/TR 17671-4		Welding — Recommendations for welding of metallic materials — Part 4: Arc welding of aluminium and aluminium alloys.	EN 1011-4	
ISO 9017		Destructive tests on welds in metallic materials — Fracture test	EN 1320	
ISO 17639		Destructive tests on welds in metallic materials — Macroscopic and microscopic examination of welds	EN 1321	
ISO 14732		Welding personnel — Approval testing of welding operators for	EN 1418	

		fusion welding and of resistance weld setters for fully mechanized and automatic welding of metallic materials		
ISO 17636		Non-destructive testing of welds — Radiographic testing of fusion-welded joints	EN 1435	
ISO 17635		Non-destructive testing of welds — General rules for fusion welds in metallic materials	EN 12062	
ISO 10042		Arc-welded joints in aluminium and its weldable alloys — Guidance on quality levels for imperfections	EN 30042	
ISO 6947		Welds — Working positions — Definitions of angles of slope and rotation.	EN ISO 6947	
ISO 9606-2		Qualification test of welders — Fusion welding — Part 2 : Aluminium and aluminium alloys	EN ISO 9606-2	
ISO 15607	2003	Specification and qualification of welding procedures for metallic materials — General rules.	EN ISO 15607	2003
ISO/TR 15608		Welding — Guidelines for a metallic material grouping system.	CR 15608	
ISO 15609-1		Specification and qualification of welding procedures for metallic materials — Welding procedure specification — Part 1: Arc welding.	EN ISO 15609-1	
ISO 15613		Specification and qualification of welding procedures for metallic materials — Qualification based on pre-production welding test.	EN ISO 15613	

Bibliography

EN ISO 4063, *Welding and allied processes — Nomenclature of processes and reference numbers (ISO 4063:1998)*.

prEN ISO 15614-4, *Specification and qualification of welding procedures for metallic materials — Welding procedure tests — Part 4 : Finishing welding of aluminium castings* .

BSI — British Standards Institution

BSI is the independent national body responsible for preparing British Standards. It presents the UK view on standards in Europe and at the international level. It is incorporated by Royal Charter.

Revisions

British Standards are updated by amendment or revision. Users of British Standards should make sure that they possess the latest amendments or editions.

It is the constant aim of BSI to improve the quality of our products and services. We would be grateful if anyone finding an inaccuracy or ambiguity while using this British Standard would inform the Secretary of the technical committee responsible, the identity of which can be found on the inside front cover. Tel: +44 (0)20 8996 9000. Fax: +44 (0)20 8996 7400.

BSI offers members an individual updating service called PLUS which ensures that subscribers automatically receive the latest editions of standards.

Buying standards

Orders for all BSI, international and foreign standards publications should be addressed to Customer Services. Tel: +44 (0)20 8996 9001. Fax: +44 (0)20 8996 7001. Email: orders@bsi-global.com. Standards are also available from the BSI website at <http://www.bsi-global.com>.

In response to orders for international standards, it is BSI policy to supply the BSI implementation of those that have been published as British Standards, unless otherwise requested.

Information on standards

BSI provides a wide range of information on national, European and international standards through its Library and its Technical Help to Exporters Service. Various BSI electronic information services are also available which give details on all its products and services. Contact the Information Centre. Tel: +44 (0)20 8996 7111. Fax: +44 (0)20 8996 7048. Email: info@bsi-global.com.

Subscribing members of BSI are kept up to date with standards developments and receive substantial discounts on the purchase price of standards. For details of these and other benefits contact Membership Administration. Tel: +44 (0)20 8996 7002. Fax: +44 (0)20 8996 7001. Email: membership@bsi-global.com.

Information regarding online access to British Standards via British Standards Online can be found at <http://www.bsi-global.com/bsonline>.

Further information about BSI is available on the BSI website at <http://www.bsi-global.com>.

Copyright

Copyright subsists in all BSI publications. BSI also holds the copyright, in the UK, of the publications of the international standardization bodies. Except as permitted under the Copyright, Designs and Patents Act 1988 no extract may be reproduced, stored in a retrieval system or transmitted in any form or by any means – electronic, photocopying, recording or otherwise – without prior written permission from BSI.

This does not preclude the free use, in the course of implementing the standard, of necessary details such as symbols, and size, type or grade designations. If these details are to be used for any other purpose than implementation then the prior written permission of BSI must be obtained.

Details and advice can be obtained from the Copyright & Licensing Manager. Tel: +44 (0)20 8996 7070. Fax: +44 (0)20 8996 7553. Email: copyright@bsi-global.com.