

**Plastics piping systems
for industrial
applications —
Acrylonitrile-
butadiene-styrene
(ABS), unplasticized
poly(vinyl chloride)
(PVC-U) and
chlorinated
poly(vinyl chloride)
(PVC-C) —
Specifications for
components and the
system — Metric series
(ISO 15493:2003)**

ICS 23.040.01

National foreword

This British Standard is the UK implementation of EN ISO 15493:2003+A1:2017. It is identical to ISO 15493:2003, incorporating amendment 1:2016. It supersedes BS EN ISO 15493:2003 which is withdrawn.

The start and finish of text introduced or altered by amendment is indicated in the text by tags. Tags indicating changes to ISO text carry the number of the ISO amendment. For example, text altered by ISO amendment 1 is indicated by **A1** **A1**.

The UK participation in its preparation was entrusted by Technical Committee PRI/88, Plastics piping systems, to Subcommittee PRI/88/2, Plastics piping for pressure applications.

A list of organizations represented on this subcommittee can be obtained on request to its secretary.

This publication does not purport to include all the necessary provisions of a contract. Users are responsible for its correct application.

Compliance with a British Standard cannot confer immunity from legal obligations.

This British Standard was published under the authority of the Standards Policy and Strategy Committee on 8 October 2003

© The British Standards Institution 2017.
Published by BSI Standards Limited 2017

Amendments/corrigenda issued since publication

Date	Comments
28 February 2017	Implementation of ISO amendment 1:2016 with CEN endorsement A1:2017

ICS 23.040.01

English version

Plastics piping systems for industrial applications - Acrylonitrile-butadiene-styrene (ABS), unplasticized poly(vinyl chloride) (PVC-U) and chlorinated poly(vinyl chloride) (PVC-C) - Specifications for components and the system - Metric series (ISO 15493:2003)

Systèmes de canalisations en matières plastiques pour les applications industrielles - Acrylonitrile-butadiène-styrène (ABS) poly(chlorure de vinyle) non plastifié (PVC-U) et poly(chlorure de vinyle) chloré (PVC-C) - Spécifications pour les composants et le système - Série métrique (ISO 15493:2003)

Kunststoff-Rohrleitungssysteme für industrielle Anwendungen - Acrylnitril-Butadien-Styrol (ABS), weichmacherfreies Polyvinylchlorid (PVC-U) und chloriertes Polyvinylchlorid (PVC-C) - Anforderungen an Rohrleitungsteile und das Rohrleitungssystem - Metrische Reihen (ISO 15493:2003)

This European Standard was approved by CEN on 11 March 2003.

CEN members are bound to comply with the CEN/CENELEC Internal Regulations which stipulate the conditions for giving this European Standard the status of a national standard without any alteration. Up-to-date lists and bibliographical references concerning such national standards may be obtained on application to the Management Centre or to any CEN member.

This European Standard exists in three official versions (English, French, German). A version in any other language made by translation under the responsibility of a CEN member into its own language and notified to the Management Centre has the same status as the official versions.

CEN members are the national standards bodies of Austria, Belgium, Czech Republic, Denmark, Finland, France, Germany, Greece, Hungary, Iceland, Ireland, Italy, Luxembourg, Malta, Netherlands, Norway, Portugal, Slovakia, Spain, Sweden, Switzerland and United Kingdom.



EUROPEAN COMMITTEE FOR STANDARDIZATION
COMITÉ EUROPÉEN DE NORMALISATION
EUROPÄISCHES KOMITEE FÜR NORMUNG

Management Centre: rue de Stassart, 36 B-1050 Brussels

CORRECTED 2003-07-16

Foreword

This document (EN ISO 15493:2003) has been prepared by Technical Committee ISO/TC 138 “Plastics pipes, fittings and valves for the transport of fluids” in collaboration with Technical Committee CEN/TC 155 “Plastics piping systems and ducting systems”, the secretariat of which is held by NEN.

This European Standard shall be given the status of a national standard, either by publication of an identical text or by endorsement, at the latest by October 2003, and conflicting national standards shall be withdrawn at the latest by October 2003.

This document has been prepared under a mandate given to CEN by the European Commission and the European Free Trade Association, and supports essential requirements of EU Directive(s).

For relationship with EU Directive(s), see informative Annex ZB, which is an integral part of this document.

According to the CEN/CENELEC Internal Regulations, the national standards organizations of the following countries are bound to implement this European Standard: Austria, Belgium, Czech Republic, Denmark, Finland, France, Germany, Greece, Hungary, Iceland, Ireland, Italy, Luxembourg, Malta, Netherlands, Norway, Portugal, Slovakia, Spain, Sweden, Switzerland and the United Kingdom.

Endorsement notice

The text of ISO 15493:2003 has been approved by CEN as EN ISO 15493:2003 without any modifications.

NOTE Normative references to International Standards are listed in annex ZA (normative).

Foreword to amendment A1

This document (EN ISO 15493:2003/A1:2017) has been prepared by Technical Committee ISO/TC 138 “Plastics pipes, fittings and valves for the transport of fluids” in collaboration with Technical Committee CEN/TC 155 “Plastics piping systems and ducting systems” the secretariat of which is held by NEN.

This Amendment to the European Standard EN ISO 15493:2003 shall be given the status of a national standard, either by publication of an identical text or by endorsement, at the latest by July 2017, and conflicting national standards shall be withdrawn at the latest by July 2017.

Attention is drawn to the possibility that some of the elements of this document may be the subject of patent rights. CEN [and/or CENELEC] shall not be held responsible for identifying any or all such patent rights.

This document has been prepared under a mandate given to CEN by the European Commission and the European Free Trade Association, and supports essential requirements of EU Directive(s).

For relationship with EU Directive(s), see informative Annex ZB, which is an integral part of EN ISO 15493:2003.

According to the CEN-CENELEC Internal Regulations, the national standards organizations of the following countries are bound to implement this European Standard: Austria, Belgium, Bulgaria, Croatia, Cyprus, Czech Republic, Denmark, Estonia, Finland, Former Yugoslav Republic of Macedonia, France, Germany, Greece, Hungary, Iceland, Ireland, Italy, Latvia, Lithuania, Luxembourg, Malta, Netherlands, Norway, Poland, Portugal, Romania, Serbia, Slovakia, Slovenia, Spain, Sweden, Switzerland, Turkey and United Kingdom.

Endorsement notice

The text of ISO 15493:2003/Amd 1:2016 + Cor 1:2004 has been approved by CEN as EN ISO 15493:2003/A1:2017 without any modification.

Contents

Page

Foreword	iv
Introduction.....	v
1 Scope.....	1
2 Normative references.....	2
3 Terms and definitions	4
4 Symbols and abbreviated terms	7
5 Material.....	8
6 General characteristics.....	10
7 Geometrical characteristics	10
8 Mechanical characteristics.....	11
9 Physical characteristics	11
10 Chemical characteristics	12
11 Adhesives	12
12 Performance requirements.....	12
13 Classification of components	13
14 Design of a thermoplastics piping system for industrial applications.....	13
15 Installation of piping systems.....	13
16 Declaration of compliance.....	14
17 Marking.....	14
Annex A (normative) Specific characteristics and requirements for industrial piping systems made from acrylonitrile-butadiene-styrene (ABS).....	16
Annex B (normative) Specific characteristics and requirements for industrial piping systems made from unplasticized poly(vinyl chloride) (PVC-U).....	30
Annex C (normative) Specific characteristics and requirements for industrial piping systems made from chlorinated poly(vinyl chloride) (PVC-C)	44
Bibliography.....	61

Foreword

ISO (the International Organization for Standardization) is a worldwide federation of national standards bodies (ISO member bodies). The work of preparing International Standards is normally carried out through ISO technical committees. Each member body interested in a subject for which a technical committee has been established has the right to be represented on that committee. International organizations, governmental and non-governmental, in liaison with ISO, also take part in the work. ISO collaborates closely with the International Electrotechnical Commission (IEC) on all matters of electrotechnical standardization.

International Standards are drafted in accordance with the rules given in the ISO/IEC Directives, Part 3.

The main task of technical committees is to prepare International Standards. Draft International Standards adopted by the technical committees are circulated to the member bodies for voting. Publication as an International Standard requires approval by at least 75 % of the member bodies casting a vote.

Attention is drawn to the possibility that some of the elements of this International Standard may be the subject of patent rights. ISO shall not be held responsible for identifying any or all such patent rights.

ISO 15493 was prepared by Technical Committee ISO/TC 138, *Plastics pipes, fittings and valves for the transport of fluids*, Subcommittee SC 3, *Plastics pipes and fittings for industrial applications*.

This document has been prepared under a mandate given by the European Commission and the European Free Trade Association and supports essential requirements of EU Directives.

At the date of publication of this International Standard, the following standards had been published for piping systems, used for industrial applications, made from other types of plastic:

ISO 10931 (all parts), *Plastics piping systems for industrial applications — Poly(vinylidene fluoride) (PVDF)*

ISO 15494, *Plastics piping systems for industrial applications — Polybutene (PB), polyethylene (PE) and polypropylene (PP) — Specifications for components and the system — Metric series*.

Annexes A, B and C form a normative part of this International Standard.

Introduction

This International Standard specifies the characteristics and requirements for a piping system and its components made from acrylonitrile-butadiene-styrene (ABS), unplasticized poly(vinyl chloride) (PVC-U) or chlorinated poly(vinyl chloride) (PVC-C), as applicable, intended to be used for industrial applications above ground by authorities, design engineers, certification bodies, inspection bodies, test laboratories, manufacturers and users.

Plastics piping systems for industrial applications — Acrylonitrile-butadiene-styrene (ABS), unplasticized poly(vinyl chloride) (PVC-U) and chlorinated poly(vinyl chloride) (PVC-C) — Specifications for components and the system — Metric series

1 Scope

This International Standard specifies the characteristics and requirements for components such as pipes, fittings and valves made from one of the following materials:

- acrylonitrile-butadiene-styrene (ABS);
- unplasticized poly(vinyl chloride) (PVC-U);
- chlorinated poly(vinyl chloride) (PVC-C);

intended to be used for thermoplastics piping systems in above-ground industrial applications.

This International Standard is applicable to ABS, PVC-U or PVC-C pipes, fittings, valves and ancillary equipment, to their joints and to joints with components made of other plastics and non-plastics materials, depending on their suitability, intended to be used for the conveyance of liquid and gaseous fluids as well as of solid matter in fluids for industrial applications such as:

- chemical plants;
- industrial sewerage engineering;
- power engineering (cooling and general-purpose water supply);
- electroplating and pickling plants;
- the semiconductor industry;
- agricultural production plants;
- water treatment.

NOTE 1 Where relevant, national regulations for specific applications (e.g. water treatment) apply.

Other application areas are permitted if the requirements of this International Standard and/or applicable national requirements are fulfilled.

Relevant regulations in respect of fire behaviour and explosion risk are applicable if applications are envisaged for inflammable media.

The components have to withstand the mechanical, thermal and chemical demands to be expected and have to be resistant to the fluids to be conveyed.

Characteristics and requirements which are applicable to all three materials (ABS, PVC-U and PVC-C) are covered by the relevant clauses of this International Standard. Those characteristics and requirements which are dependent on the material are given for each material in the relevant annex (see Table 1).

Table 1 — Material-specific annexes

Material	Annex
Acrylonitrile-butadiene-styrene (ABS)	A
Unplasticized poly(vinyl chloride) (PVC-U)	B
Chlorinated poly(vinyl chloride) (PVC-C)	C

NOTE 2 Components conforming to any of the product standards listed in the bibliography or to national standards, as applicable, may be used with components conforming to this International Standard provided they conform to the requirements for joint dimensions and to the other relevant requirements of this standard.

2 Normative references

The following normative documents contain provisions which, through reference in this text, constitute provisions of this International Standard. For dated references, subsequent amendments to, or revisions of, any of these publications do not apply. However, parties to agreements based on this International Standard are encouraged to investigate the possibility of applying the most recent editions of the normative documents indicated below. For undated references, the latest edition of the normative document referred to applies. Members of ISO and IEC maintain registers of currently valid International Standards.

ISO 7-1, *Pipe threads where pressure-tight joints are made on the threads — Part 1: Dimensions, tolerances and designation*

ISO 228-1, *Pipe threads where pressure-tight joints are not made on the threads — Part 1: Dimensions, tolerances and designation*

ISO 265-1, *Pipes and fittings of plastics materials — Fittings for domestic and industrial waste pipes — Basic dimensions: Metric series — Part 1: Unplasticized poly(vinyl chloride) (PVC-U)*

ISO 306, *Plastics — Thermoplastic materials — Determination of Vicat softening temperature (VST)*

ISO 472, *Plastics — Vocabulary*

ISO 580:—¹⁾, *Injection-moulded unplasticized poly(vinyl chloride) (PVC-U) fittings — Oven test — Test method and basic specifications*

ISO 727-1, *Fittings made from unplasticized poly(vinyl chloride) (PVC-U), chlorinated poly(vinyl chloride) (PVC-C) or acrylonitrile/butadiene/styrene (ABS) with plain sockets for pipes under pressure — Part 1: Metric series*

ISO 1043-1, *Plastics — Symbols and abbreviated terms — Part 1: Basic polymers and their special characteristics*

ISO 1158, *Plastics — Vinyl chloride homopolymers and copolymers — Determination of chlorine content*

^{A1)} ISO 1167-1, *Thermoplastics pipes, fittings and assemblies for the conveyance of fluids — Determination of the resistance to internal pressure — Part 1: General method ^{A1}*

1) To be published. (Revision of ISO 580:1990)

ISO 1183-2, *Plastics — Methods for determining the density of non-cellular plastics — Part 2: Density gradient column method*

ISO 2505-1:1994, *Thermoplastics pipes — Longitudinal reversion — Part 1: Determination methods*

ISO 2505-2:1994, *Thermoplastics pipes — Longitudinal reversion — Part 2: Determination parameters*

ISO 2507-1, *Thermoplastics pipes and fittings — Vicat softening temperature — Part 1: General test method*

ISO 2507-2, *Thermoplastics pipes and fittings — Vicat softening temperature — Part 2: Test conditions for unplasticized poly(vinyl chloride) (PVC-U) or chlorinated poly(vinyl chloride) (PVC-C) pipes and fittings and for high impact resistance poly(vinyl chloride) (PVC-HI) pipes*

ISO 3126, *Plastics piping systems — Plastics piping components — Measurement and determination of dimensions*

ISO 3127, *Thermoplastics pipes — Determination of resistance to external blows — Round-the-clock method*

ISO 3514, *Chlorinated polyvinyl chloride (CPVC) pipes and fittings — Specification and determination of density*

ISO 4065, *Thermoplastics pipes — Universal wall thickness table*

ISO 9080, *Plastics piping and ducting systems — Determination of the long-term hydrostatic strength of thermoplastics materials in pipe form by extrapolation*

ISO 9311-1, *Adhesives for thermoplastics piping systems — Part 1: Determination of film properties*

ISO 9852, *Unplasticized poly(vinyl chloride) (PVC-U) pipes — Dichloromethane resistance at specified temperature (DCMT) — Test method*

ISO 9853, *Injection-moulded unplasticized poly(vinyl chloride) (PVC-U) fittings for pressure pipe systems — Crushing test*

ISO/TR 10358, *Plastics pipes and fittings — Combined chemical-resistance classification table*

ISO 11922-1:1997, *Thermoplastics pipes for the conveyance of fluids — Dimensions and tolerances — Part 1: Metric series*

A1 Text deleted A1

ISO 12162, *Thermoplastics materials for pipes and fittings for pressure applications — Classification and designation — Overall service (design) coefficient*

ISO 15853, *Thermoplastics materials — Preparation of tubular test pieces for the determination of the hydrostatic strength of materials used for injection moulding*

ISO 16135:—²⁾, *Industrial valves — Ball valves of thermoplastics materials*

ISO 16136:—²⁾, *Industrial valves — Butterfly valves of thermoplastics materials*

ISO 16137:—²⁾, *Industrial valves — Check valves of thermoplastics materials*

ISO 16138:—²⁾, *Industrial valves — Diaphragm valves of thermoplastics materials*

ISO 16139:—²⁾, *Industrial valves — Gate valves of thermoplastics materials*

ISO 21787:—²⁾, *Industrial valves — Globe valves of thermoplastics materials*

2) To be published.

3 Terms and definitions

For the purposes of this International Standard, the terms and definitions given in ISO 472 and ISO 1043-1 and the following apply.

3.1 Geometrical definitions

NOTE The symbols d_e and e correspond to d_{ey} and e_y given in other International Standards such as ISO 11922-1.

3.1.1 nominal outside diameter

d_n
specified outside diameter of a component, which is identical to the minimum mean outside diameter, $d_{em,min}$, in millimetres

NOTE The nominal inside diameter of a socket is equal to the nominal outside diameter of the corresponding pipe.

3.1.2 outside diameter at any point

d_e
outside diameter measured through the cross-section at any point on a pipe, or the spigot end of a fitting, rounded up to the nearest 0,1 mm

3.1.3 mean outside diameter

d_{em}
measured length of the outer circumference of a pipe, or the spigot end of a fitting, divided by π ($\approx 3,142$), rounded up to the nearest 0,1 mm

3.1.4 mean inside diameter of a socket

d_{im}
arithmetic mean of two measured inside diameters perpendicular to each other

3.1.5 nominal size of flange DN

numerical designation for the size of a flange for reference purposes, related to the manufactured dimension in millimetres

3.1.6 out-of-roundness

difference between the measured maximum outside diameter and the measured minimum outside diameter in the same cross-sectional plane of a pipe, or the spigot end of a fitting, or the difference between the measured maximum inside diameter and the measured minimum inside diameter in the same cross-sectional plane of a socket

3.1.7 nominal wall thickness

e_n
wall thickness, in millimetres, corresponding to the minimum wall thickness, e_{min}

3.1.8 wall thickness at any point

e
measured wall thickness at any point around the circumference of a component, rounded up to the nearest 0,1 mm

3.1.9

pipe series

S
dimensionless number related to the nominal outside diameter, d_n , and the nominal wall thickness, e_n

NOTE 1 The pipe series S is related to the pipe geometry as shown in equation (1):

$$S = \frac{d_n - e_n}{2e_n} \quad (1)$$

NOTE 2 Flanges are designated on the basis of PN.

3.1.10

standard dimension ratio

SDR

ratio of the nominal outside diameter, d_n , of a pipe to its nominal wall thickness, e_n

NOTE In accordance with ISO 4065, the standard dimension ratio SDR and the pipe series S are related as shown in equation (2):

$$\text{SDR} = 2S + 1 \quad (2)$$

3.2 Definitions of materials

3.2.1

virgin material

material in a form such as granules or powder that has not been previously processed other than for compounding and to which no reprocessable or recyclable materials have been added

3.2.2

reprocessable material

material prepared from clean unused rejected pipes, fittings or valves, produced in a manufacturer's plant by a process such as moulding or extrusion, which will be reprocessed in the same plant and for which the complete formulation or material specification is known

NOTE 1 Such material may include trimmings from the production of such pipes, fittings and valves.

NOTE 2 In the case of valves, only those thermoplastics parts which are made from material conforming to this International Standard may be considered as reprocessable material.

3.3 Definitions related to material characteristics

3.3.1

lower confidence limit

σ_{LCL}

quantity with the dimensions of stress, expressed in megapascals, which can be considered as a property of the material and represents the 97,5 % lower confidence limit of the predicted long-term hydrostatic strength at a given temperature, T , and time, t , determined by pressurizing internally with water

3.3.2

minimum required strength

MRS

value of σ_{LCL} at 20 °C and 50 years, rounded down to the next lower value in the R 10 series when σ_{LCL} is less than 10 MPa, or to the next lower value in the R 20 series when σ_{LCL} is greater than or equal to 10 MPa

NOTE The R 10 and R 20 series are the Renard number series as defined in ISO 3 and ISO 497.

3.3.3 design stress

σ_s
allowable stress, in megapascals, for a given application or set of service conditions

NOTE It is derived by dividing the MRS by the coefficient C , as in equation (3), then rounding to the next lower value in the R 10 or R 20 series, as applicable:

$$\sigma_s = \frac{\text{MRS}}{C} \quad (3)$$

3.3.4 overall service (design) coefficient

C
overall coefficient, with a value greater than one, which takes into consideration service conditions as well as the properties of the components of a piping system other than those represented in the lower confidence limit, σ_{LCL}

3.4 Definitions related to service conditions

3.4.1 nominal pressure PN

numerical designation used for reference purposes and related to the mechanical characteristics of the components of a piping system

NOTE 1 A pressure, in bars, numerically equal to PN is identical to the maximum allowable pressure, PS, as defined by EU Directive 97/23/ECC (PED), if both pressures are taken at 20 °C.

NOTE 2 For plastics piping systems conveying water, PN corresponds to the maximum continuous operating pressure in bars which can be sustained for water at 20 °C for 50 years, based on the minimum overall service (design) coefficient and calculated using the following equation:

$$\text{PN} = \frac{10\sigma_s}{S} = \frac{20\sigma_s}{\text{SDR} - 1} \quad (4)$$

where

σ_s is expressed in N/mm²;

PN is expressed in bars³⁾.

3.4.2 hydrostatic stress

σ
stress induced in the wall of a pipe when an internal hydrostatic pressure is applied

NOTE 1 The hydrostatic stress, in megapascals, is related to the applied internal hydrostatic pressure, p , the wall thickness, e , at any point and the mean outside diameter, d_{em} , of a pipe and calculated using the following equation:

$$\sigma = p \times \frac{d_{\text{em}} - e}{2e} \quad (5)$$

NOTE 2 Equation (5) is applicable to pipes only.

3) A_1 1 bar = 0,1 MPa = 10⁵ Pa; 1 MPa = 1 N/mm². A_1

3.4.3

long-term hydrostatic stress

constant hydrostatic stress that is maintained in a component for a sustained period of time

4 Symbols and abbreviated terms

4.1 Symbols

C	overall service (design) coefficient (design factor)
d_e	outside diameter (at any point)
d_{em}	mean outside diameter
d_{im}	mean inside diameter of socket
d_n	nominal outside diameter
DN	nominal size of flange
e	wall thickness (at any point)
e_n	nominal wall thickness
l_0	free length
p	internal hydrostatic pressure
t	time
T	temperature
ρ	density of material
σ	hydrostatic stress
σ_{LCL}	lower confidence limit
σ_s	design stress

4.2 Abbreviations

ABS	acrylonitrile-butadiene-styrene
MRS	minimum required strength
PVC-C	chlorinated poly(vinyl chloride)
PVC-U	unplasticized poly(vinyl chloride)
PN	nominal pressure
PS	maximum allowable pressure
PT	test pressure (corresponds to the symbol p usually used)
S	pipe series
SDR	standard dimension ratio
TIR	true impact rate

5 Material

5.1 General

^{A1} The material from which the components are made shall be ABS, PVC-U or PVC-C, as applicable, to which are added those additives that are needed to facilitate the manufacture of pipes, fittings, valves, appurtenances and assemblies conforming to this document. ^{A1}

If additives are used, they shall be uniformly dispersed.

Additives shall not be used, separately or together, in quantities sufficient to impair the fabrication or solvent-cementing characteristics of the components or to impair the chemical, physical or mechanical characteristics as specified in this International Standard.

5.2 Hydrostatic strength properties

The material shall be evaluated in accordance with ISO 9080 where a pressure test is carried out in accordance with ISO 1167 to find the MRS-value in accordance with ISO 12162. The test shall be carried out using test pieces of pipe series S \leq 12,5.

Conformity of the relevant material to the reference curves given for ABS (see Annex A), PVC-U (see Annex B) and PVC-C (see Annex C) shall be demonstrated in accordance with the applicable annex to this International Standard. At least 97,5 % of the data points shall be on or above the reference curves.

The material shall be as classified by the raw-material producer.

^{A1} NOTE In some cases, the component manufacturer may be regarded as the raw material producer. ^{A1}

Where fittings and valves are manufactured from the same material as pipes, the material classification shall be the same as for pipes.

For the classification of a material intended only for the manufacture of fittings and valves, an injection-moulded or extruded test piece in the form of a pipe shall be used (see Figure 1) and the test pressure applied in accordance with ISO 1167. The free length l_0 shall be $3d_n$, as defined in ISO 15853.

5.3 Other characteristics of material

Details of requirements on other characteristics of ABS, PVC-U and PVC-C material are given in the applicable annex to this International Standard.

5.4 Reprocessable and recyclable material

The use of reprocessible material obtained during the production and testing of components in accordance with this International Standard is permitted in addition to virgin material, provided that the requirements of this International Standard are fulfilled.

Reprocessible material obtained from external sources and recyclable material shall not be used.

5.5 Parts not made from ABS, PVC-U or PVC-C

5.5.1 General

All components shall conform to the relevant International Standards. Alternative standards may be used in cases where suitable International Standards do not exist. In all cases, the fitness for purpose of the components shall be demonstrated.

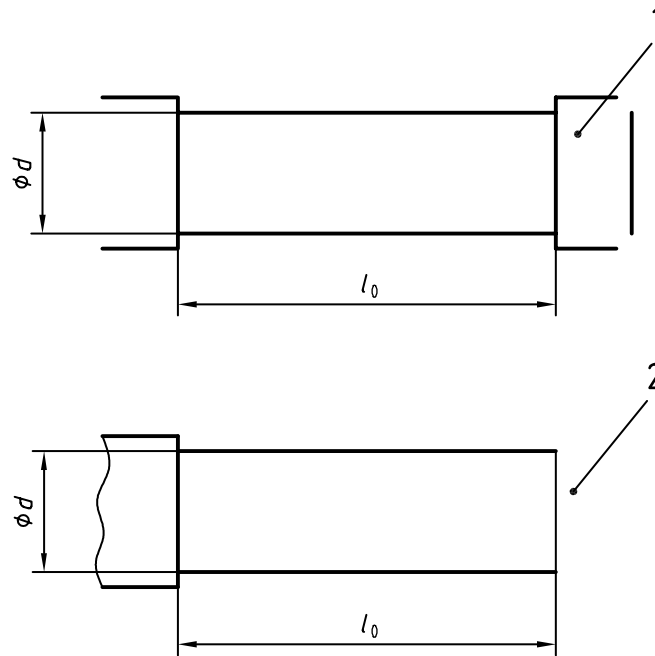

Key

- 1 End cap
- 2 Injection-moulded end

Figure 1 — Free length, l_0 , of test piece

Materials and constituent elements used in making a particular component (including rubber, greases and any metal parts that may be used) shall have resistance to the external and internal environments which is comparable to that of all other elements of the piping system.

Materials other than ABS, PVC-U or PVC-C in contact with components conforming to this International Standard shall not adversely effect the performance of the components or initiate stress cracking.

5.5.2 Metallic materials

All metal parts susceptible to corrosion shall be adequately protected.

When dissimilar metallic materials are used which can be in contact with moisture, steps shall be taken to avoid galvanic corrosion.

5.5.3 Sealing materials

Sealing materials shall have no detrimental effects on the properties of the components, joints and assemblies.

5.5.4 Other materials

Greases or lubricants shall not exude onto solvent cement areas and shall not affect the long-term performance of materials conforming to this International Standard.

6 General characteristics

6.1 Appearance

When viewed without magnification, the internal and external surfaces of the components shall be smooth, clean and free from any scoring, cavities and other surface defects that would prevent conformity to this International Standard. The components shall not contain visible impurities.

Each end of a component shall be square to its axis and shall be deburred.

6.2 Colour

The colour of the components will depend on the material used and shall be as given for ABS, PVC-U or PVC-C in the applicable annex to this International Standard.

NOTE Attention is drawn to the need to take account of any relevant legislation relating to the colour coding of piping in respect of its purpose or contents for the location in which the components are intended to be used.

Components for external above-ground installations shall be adequately protected against UV radiation.

7 Geometrical characteristics

7.1 General

Dimensions shall be measured in accordance with ISO 3126 at (23 ± 2) °C after the component has been conditioned for at least 4 h. The measurements shall not be made less than 24 h after manufacture.

The illustrations given in this International Standard are schematic sketches only, to indicate the relevant dimensions. They do not necessarily represent manufactured components. The dimensions given shall be followed. Dimensions not given shall be as specified by the manufacturer.

7.2 Diameters and associated tolerances

For components made from ABS, PVC-U or PVC-C, as applicable, the diameters and associated tolerances shall conform to the applicable annex to this International Standard.

The out-of-roundness shall be measured at the point of manufacture.

7.3 Wall thicknesses and associated tolerances

For components made from ABS, PVC-U or PVC-C, as applicable, the wall thicknesses and associated tolerances shall conform to the applicable annex to this International Standard.

7.4 Angles

The permitted deviation from the nominal or declared angle of a non-linear fitting (i.e. the change in direction of the axis of flow through the fitting) is $\pm 2^\circ$.

NOTE The preferred nominal angle for a non-linear fitting is 45° or 90° .

7.5 Laying lengths

The laying lengths for fittings and valves shall be as declared by the manufacturer.

NOTE The laying lengths are intended to assist in the design of moulds and are not intended to be used for quality control purposes. ISO 265-1 may be used as a guide.

7.6 Threads

Threads used for jointing shall conform to ISO 7-1. Where a thread is used as a fastening thread for jointing an assembly (e.g. union nuts), a thread conforming to ISO 228-1 is preferred.

7.7 Mechanical fittings

Mechanical fittings such as adaptors, unions, compression fittings and reducing bushes may be used provided that their joint dimensions are in accordance with the applicable dimensions of components conforming to this International Standard.

7.8 Joint dimensions of valves

The joint dimensions of valves shall conform to the relevant dimensions of pipes and fittings conforming to this International Standard.

8 Mechanical characteristics

8.1 Resistance to internal pressure of components

Components shall withstand the hydrostatic stress induced by internal hydrostatic pressure without bursting or leakage when tested in accordance with ISO 1167 (for fittings, together with ISO 12092) under the test conditions specified for ABS, PVC-U or PVC-C in the applicable annex to this International Standard.

8.2 Calculation of the test pressure for components

8.2.1 Pipes

The hydrostatic test pressure, PT, in bars, shall be determined for pipes using the following equation:

$$\sigma = PT \times \frac{d_{em} - e_{min}}{2e_{min}} \quad (6)$$

where σ is the hydrostatic stress for ABS, PVC-U or PVC-C as given in the applicable annex to this International Standard.

8.2.2 Fittings

The hydrostatic test pressure, PT, in bars, shall be determined for fittings using equation (7). For S and SDR, the respective values for the corresponding pipe shall be taken.

$$PT = \frac{10\sigma}{S} = \frac{20\sigma}{SDR - 1} \quad (7)$$

8.2.3 Valves

The hydrostatic test pressure, PT, in bars, is defined for valves in ISO 16135, ISO 16136, ISO 16137, ISO 16138, ISO 16139 or ISO 21787, as applicable, depending on the valve type.

9 Physical characteristics

The physical characteristics of components made from ABS, PVC-U or PVC-C shall conform to the applicable annex to this International Standard.

10 Chemical characteristics

10.1 Effects on the component material(s)

Where fluids other than water are to be conveyed, the effect of the fluid on the component material(s) may be established by consulting the component manufacturer or by reference to ISO/TR 10358.

10.2 Effects on the fluids

Where fluids other than water are to be conveyed, the effect on the fluids may be established by consulting the component manufacturer.

11 Adhesives

^{A1} The adhesive(s) shall be as recommended by the manufacturer of the components.

The adhesive(s) shall not cause the test assembly to fail to conform to the requirements given in the applicable annex to this document. ^{A1}

12 Performance requirements

12.1 General

When components made from the same material, conforming to this International Standard, are jointed to each other, all pipes, fittings and valves, as well as the joints between them, shall conform to the requirements of the applicable annex to this International Standard.

NOTE If test pressures defined for pipes are used for assemblies made from components of dissimilar materials (e.g. threaded joints or flanged joints), the resulting strain exceeds the strain occurring under service conditions. These strains inevitably cause leakage. Therefore, in this International Standard, the time-related strain behaviour of the assemblies is taken into account and test pressures derived from the isochronous stress-strain diagram are used.

12.2 Preparation of test assemblies

12.2.1 General

The joints shall be tested using pipes and fittings conforming to this International Standard.

The preparation of test assemblies shall take into account tolerances related to component manufacture, field assembly and the equipment used, ambient-temperature variations during installation and, where appropriate, sealing material and associated tolerances.

Test assemblies for pressure tests shall be closed with pressure-tight end-load-bearing end caps, plugs or flanges which shall be provided with connections for the entry of water and release of air.

12.2.2 Solvent cement jointing

Pipes and fittings designed for solvent cement jointing shall be prepared and assembled in accordance with the manufacturer's instructions.

12.2.3 Mechanical jointing

Pipes and fittings designed for mechanical jointing shall be prepared and assembled in accordance with the manufacturer's instructions.

13 Classification of components

The classification of pipes shall be based on the pipe series S or the standard dimension ratio SDR or the nominal pressure PN, as applicable.

The classification of fittings shall be based on that of the corresponding pipe together with the pipe series S or the standard dimension ratio SDR or the nominal pressure PN, as applicable.

Valves shall be classified in accordance with the requirements of ISO 16135, ISO 16136, ISO 16137, ISO 16138, ISO 16139 or ISO 21787, as applicable, depending on the valve type.

14 Design of a thermoplastics piping system for industrial applications

NOTE Due to the fact that there are several calculation methods available for the design of thermoplastics piping systems for industrial applications, only general guidance can be given.

For the design of a piping system (e.g. determination of the maximum allowable pressure, p_s), the following parameters should be taken into account:

- the temperature, T , usually constant (if not, then Miner's rule should be used);
- the pressure, p , usually constant (if not, then Miner's rule should be used);
- the lifetime, t (usually 25 years);
- the stress, σ , calculated using the equations given in the first clause of Annex A, B or C, as applicable;
- the chemical resistance of the material to the fluid;
- the required design factor, C ;
- the influence of wear and abrasion by any solid matter in the fluid;
- the influence of changes in length (caused by temperature, swelling, internal pressure);
- the kind of installation (fixed, floating, etc.);
- the distances between supports in the installed piping system.

With these parameters, together with the minimum required hydrostatic strength curves, a piping system can be designed taking into account any national and/or local requirements and, where appropriate, backed up by experimental design methods.

15 Installation of piping systems

For the installation of components conforming to this International Standard, national and/or local requirements and relevant codes of practice shall apply.

In addition, the pipe manufacturer may provide a recommended practice for installation covering transport, storage and handling of the components, as well as their installation in accordance with applicable national and/or local requirements.

For external above-ground installation, additional requirements depending on the climate shall be agreed on between manufacturer and purchaser.

16 Declaration of compliance

The manufacturer shall declare compliance with this International Standard by marking components in accordance with clause 17.

17 Marking

17.1 General

Marking elements shall be printed or formed directly on the component, or printed on a label, in such a way that legibility is not affected by storage, weathering, handling or installation.

NOTE The manufacturer is not responsible for the marking on a component becoming illegible due to actions caused during installation and use such as painting, scratching or covering over, or the use of detergents, etc., unless agreed with or specified by the manufacturer.

Marking shall not initiate cracks or other types of defect which adversely influence the performance of the component.

If printing is used, the colour of the printed information shall differ from the basic colour of the component.

The size of the marking shall be such that the marking is legible without magnification.

17.2 Minimum required marking of pipes

The minimum required marking of pipes is given in Table 2.

Pipes shall be marked at intervals of maximum 1 m, at least once per pipe.

Table 2 — Minimum required marking of pipes

Information	Marking or symbol
Number of this International Standard	ISO 15493
Manufacturer's name and/or trade mark	Name or symbol
Nominal outside diameter, d_n	e.g. 110
Nominal wall thickness, e_n or pipe series S or standard dimension ratio SDR or nominal pressure PN	e.g. 5,3 e.g. S 10 or SDR 21 e.g. PN 10
Material	e.g. PVC-U
Manufacturer's information	^a
^a To provide traceability, the following details shall be given: <ul style="list-style-type: none"> — the production period (year and month), in figures or in code form; — a name or code for the production site if the manufacturer is producing at different sites. 	

17.3 Minimum required marking of fittings

The minimum required marking of fittings is given in Table 3.

Table 3 — Minimum required marking of fittings

Information	Marking or symbol
Number of this International Standard ^a	ISO 15493
Manufacturer's name and/or trade mark	Name or symbol
Nominal outside diameter(s), d_n	e.g. 63-32-63
Nominal wall thickness, e_n or Pipe series S or standard dimension ratio SDR or nominal pressure PN	e.g. 5,8 e.g. S 10 or SDR 21 e.g. PN 10
Nominal size DN ^b	e.g. DN 50
Material	e.g. PVC-U
Manufacturer's information	^c
^a This information shall be marked at least on the packaging. ^b Applicable to flanges only. ^c For fittings with $d_n > 32$ mm, the following details shall be given to provide traceability: — the production period (year and month), in figures or in code form; — a name or code for the production site if the manufacturer is producing at different sites.	

17.4 Minimum required marking of valves

Valves shall be marked in accordance with the requirements of ISO 16135, ISO 16136, ISO 16137, ISO 16138, ISO 16139 or ISO 21787, as applicable, depending on the valve type.

Annex A (normative)

Specific characteristics and requirements for industrial piping systems made from acrylonitrile-butadiene-styrene (ABS)

A.1 Material

A.1.1 Material for components

The material shall be tested in accordance with 5.2 at 20 °C, 40 °C and 60 °C as well as at various hydrostatic (hoop) stresses in such a way that, at each temperature, at least three failure times fall in each of the following time intervals:

- 10 h to 100 h;
- 100 h to 1 000 h;
- 1 000 h to 8 760 h;
- > 8 760 h.

In tests lasting more than 8 760 h, any time reached which corresponds to a point on or above the relevant reference curve may be considered as a failure time.

The values of the minimum required hydrostatic strength (see reference curves given in Figure A.1) in the temperature range of 10 °C to 60 °C were calculated using the following equation:

$$\log t = -154,8961 - 35\,935,57 \times \frac{\log \sigma}{T} + 55\,180,34 \times \frac{1}{T} + 98,73749 \times \log \sigma \quad (\text{A.1})$$

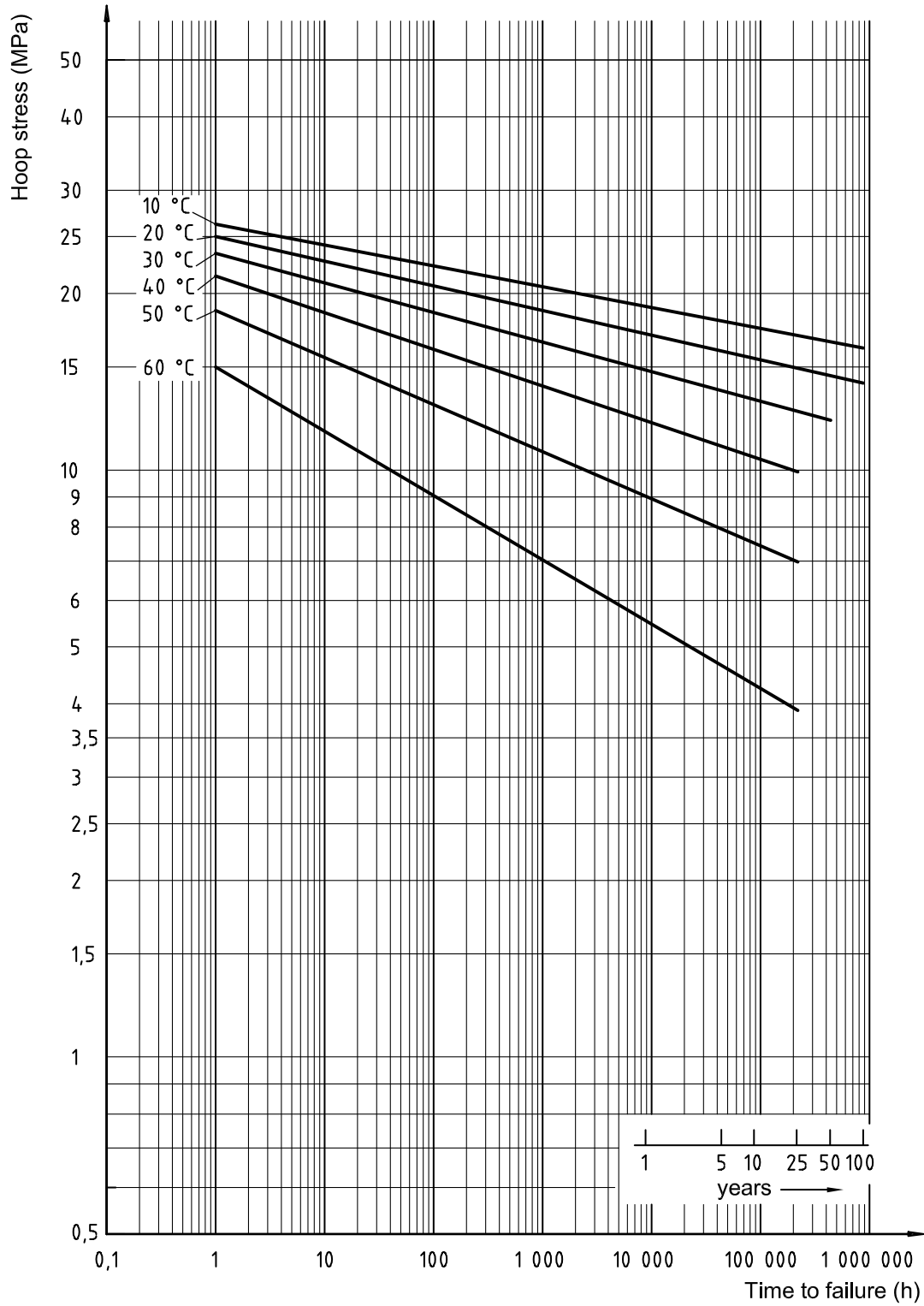

Figure A.1 — Minimum required hydrostatic strength curves for ABS

A.1.2 MRS-value

When evaluated in accordance with 5.2, ABS material shall have an MRS at least equal to 14,0 MPa.

A.1.3 Density of material

The density of the material from which the components are manufactured shall conform to the requirement given in Table A.1.

Table A.1 — Density of ABS material

Characteristic	Requirement ^a	Test temperature	Test method
Density, ρ (kg/m ³)	$1\,000 \leq \rho \leq 1\,070$	23 °C	ISO 1183-2
^a Conformity to this requirement shall be declared by the raw-material producer.			

A.2 General characteristics — Colour

Components made from ABS should preferably be grey. Other colours shall be agreed on between manufacturer and purchaser.

A.3 Geometrical characteristics

A.3.1 Dimensions of pipes

A.3.1.1 Diameters and associated tolerances

The mean outside diameter, d_{em} , determined as the average value of measurements made at distances of d_n and $0,1d_n$ from the end of the test piece, shall be as specified in Table A.2.

A.3.1.2 Out-of-roundness

The out-of-roundness, measured at the point of manufacture, shall be as specified Table A.2. If values for the out-of-roundness other than those given in Table A.2 are necessary, they shall be agreed on between manufacturer and purchaser.

Table A.2 — Mean outside diameters, associated tolerances and out-of-roundness of pipes

Dimensions in millimetres

Nominal outside diameter d_n	Mean outside diameter d_{em} min.	Tolerance on outside diameter ^a	Out-of-roundness ^b max.
12	12,0	+ 0,2	0,5
16	16,0	+ 0,2	0,5
20	20,0	+ 0,2	0,5
25	25,0	+ 0,2	0,5
32	32,0	+ 0,2	0,5
40	40,0	+ 0,2	0,5
50	50,0	+ 0,2	0,6
63	63,0	+ 0,3	0,8
75	75,0	+ 0,3	0,9
90	90,0	+ 0,3	1,1
110	110,0	+ 0,4	1,4
125	125,0	+ 0,4	1,5
140	140,0	+ 0,5	1,7
160	160,0	+ 0,5	2,0
180	180,0	+ 0,6	2,2
200	200,0	+ 0,6	2,4
225	225,0	+ 0,7	2,7
250	250,0	+ 0,8	3,0
280	280,0	+ 0,9	3,4
315	315,0	+ 1,0	3,8
355	355,0	+ 1,1	4,3
400	400,0	+ 1,2	4,8

^a The tolerances correspond to Grade D of ISO 11922-1:1997 for $d_n \leq 50$ mm and to Grade C of ISO 11922-1:1997 for $d_n > 50$ mm.

^b The tolerances correspond to $0,5 \times$ Grade M of ISO 11922-1:1997.

A.3.1.3 Wall thicknesses and associated tolerances

The wall thickness, e , and the associated tolerance shall be as specified in Table A.3.

Table A.3 — Wall thicknesses and associated tolerances

Dimensions in millimetres

Nominal outside diameter d_n	Wall thickness, e , and associated tolerance ^a																		
	Pipe series S and standard dimension ratio SDR																		
	S 20 SDR 41		S 16 SDR 33		S 12,5 SDR 26		S 10 SDR 21		S 8 SDR 17		S 6,3 SDR 13,6		S 5 SDR 11		S 4 SDR 9		b		
e min.	c	e min.	c	e min.	c	e min.	c	e min.	c	e min.	c	e min.	c	e min.	c	e min.	c		
12	—	—	—	—	—	—	—	—	—	—	—	—	—	1,5	+0,4	1,5	+0,4	—	—
16	—	—	—	—	—	—	—	—	—	—	—	1,5	+0,4	1,5	+0,4	1,8	+0,4	1,4	+0,4
20	—	—	—	—	—	—	—	—	—	—	—	1,5	+0,4	1,9	+0,4	2,3	+0,5	1,5	+0,4
25	—	—	—	—	—	—	—	—	—	1,5	+0,4	1,9	+0,4	2,3	+0,5	2,8	+0,5	1,8	+0,4
32	—	—	—	—	—	—	—	1,6	+0,4	1,9	+0,4	2,4	+0,5	2,9	+0,5	3,6	+0,6	2,0	+0,4
40	—	—	—	—	1,6	+0,4	1,9	+0,4	2,4	+0,5	3,0	+0,5	3,7	+0,6	4,5	+0,7	2,5	+0,5	
50	—	—	1,6	+0,4	2,0	+0,4	2,4	+0,5	3,0	+0,5	3,7	+0,6	4,6	+0,7	5,6	+0,8	3,1	+0,6	
63	1,6	+0,4	2,0	+0,4	2,5	+0,5	3,0	+0,5	3,8	+0,6	4,7	+0,7	5,8	+0,8	7,1	+1,0	3,9	+0,6	
75	1,9	+0,4	2,3	+0,5	2,9	+0,5	3,6	+0,6	4,5	+0,7	5,6	+0,8	6,8	+0,9	8,4	+1,1	4,6	+0,7	
90	2,2	+0,5	2,8	+0,5	3,5	+0,6	4,3	+0,7	5,4	+0,8	6,7	+0,9	8,2	+1,1	10,1	+1,3	5,6	+0,8	
110	2,7	+0,5	3,4	+0,6	4,2	+0,7	5,3	+0,8	6,6	+0,9	8,1	+1,1	10,0	+1,2	12,3	+1,5	6,8	+0,9	
125	3,1	+0,6	3,9	+0,6	4,8	+0,7	6,0	+0,8	7,4	+1,0	9,2	+1,2	11,4	+1,4	14,0	+1,6	7,7	+1,0	
140	3,5	+0,6	4,3	+0,7	5,4	+0,8	6,7	+0,9	8,3	+1,1	10,3	+1,3	12,7	+1,5	15,7	+1,8	8,6	+1,1	
160	4,0	+0,6	4,9	+0,7	6,2	+0,9	7,7	+1,0	9,5	+1,2	11,8	+1,4	14,6	+1,7	17,9	+2,0	9,9	+1,2	
180	4,4	+0,7	5,5	+0,8	6,9	+0,9	8,6	+1,1	10,7	+1,3	13,3	+0,6	16,4	+1,9	20,1	+2,3	—	—	
200	4,9	+0,7	6,2	+0,9	7,7	+1,0	9,6	+1,2	11,9	+1,4	14,7	+1,7	18,2	+2,1	22,4	+2,5	12,3	+1,5	
225	5,5	+0,8	6,9	+0,9	8,6	+1,1	10,8	+1,3	13,4	+1,6	16,6	+1,9	20,5	+2,3	25,2	+2,8	13,9	+1,6	
250	6,2	+0,9	7,7	+1,0	9,6	+1,2	11,9	+1,4	14,8	+1,7	18,4	+2,1	22,7	+2,5	27,9	+3,0	15,6	+1,8	
280	6,9	+0,9	8,6	+1,1	10,7	+1,3	13,4	+1,6	16,6	+1,9	20,6	+2,3	25,4	+2,8	31,3	+3,4	17,5	+2,0	
315	7,7	+1,0	9,7	+1,2	12,1	+1,5	15,0	+1,7	18,7	+2,1	23,2	+2,6	28,6	+3,1	35,2	+3,8	19,7	+2,2	
355	8,7	+1,1	10,9	+1,3	13,6	+1,6	16,9	+1,9	21,1	+2,4	26,1	+2,9	32,2	+3,5	39,7	+4,2	22,2	+2,5	
400	9,8	+1,2	12,3	+1,5	15,3	+1,8	19,1	+2,2	23,7	+2,6	29,4	+3,2	36,3	+3,9	44,7	+4,7	25,0	+2,7	

NOTE For safety reasons, the minimum wall thickness should be not less than 1,5 mm.

^a Except where otherwise stated, dimensions correspond to those given in ISO 4065.

^b These wall thicknesses existed on the market at the time of publication of this International Standard. It can be assumed that, in the course of time, they will be replaced by pipe series in accordance with ISO 4065.

^c The tolerances have been calculated from the expression $(0,1e + 0,2)$ mm and rounded up to the nearest 0,1 mm.

A.3.2 Dimensions of sockets for solvent cementing

The dimensions of sockets for solvent cementing (see Figure A.2) shall be as specified in Table A.4.

A.3.3 Dimensions of fittings

A.3.3.1 General

This annex is applicable to the following types of fitting:

- fittings for solvent cementing;
- flange adaptors and loose backing flanges;
- mechanical fittings.

A.3.3.2 Fittings for solvent cementing

A.3.3.2.1 Nominal diameter(s)

The nominal diameter(s), d_n , of a fitting for solvent cementing shall correspond to, and be designated by, the nominal outside diameter(s) of the pipe(s) for which the fitting is designed.

A.3.3.2.2 Diameters and lengths of sockets

The diameters and lengths of sockets for solvent cementing (see Figure A.2) shall be as specified in Table A.4.

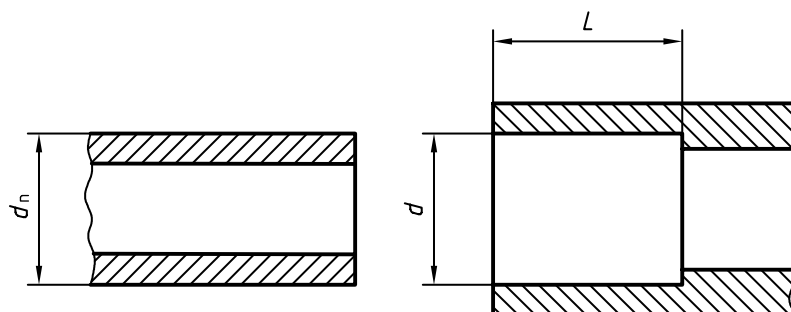

Key

- d_n nominal outside diameter
- d_i inside diameter of socket at midpoint of socket length
- L length of socket, i.e. distance from socket mouth to shoulder, if any

Figure A.2 — Diameters and lengths of sockets for solvent cementing

Table A.4 — Diameters and lengths of sockets for solvent cementing

Dimensions in millimetres

Nominal outside diameter of pipe d_n	Mean inside diameter of socket d_{im}		Out-of-roundness ^a max.	Socket length ^b L min.
	min.	max.		
12	12,1	12,3	0,25	11,0
16	16,1	16,3	0,25	13,0
20	20,1	20,3	0,25	15,0
25	25,1	25,3	0,25	17,5
32	32,1	32,3	0,25	21,0
40	40,1	40,3	0,25	25,0
50	50,1	50,3	0,3	30,0
63	63,1	63,3	0,4	36,5
75	75,1	75,3	0,5	42,5
90	90,1	90,3	0,6	50,0
110	110,1	110,4	0,7	60,0
125	125,1	125,4	0,8	67,5
140	140,2	140,5	0,9	75,0
160	160,2	160,5	1,0	85,0
180	180,2	180,6	1,1	95,0
200	200,2	200,6	1,2	105,0
225	225,3	225,7	1,4	117,5
250	250,3	250,8	1,5	130,0
280	280,3	280,9	1,7	145,0
315	315,4	316,0	1,9	162,5
355	355,5	356,2	2,2	182,5
400	400,5	401,5	2,4	205,0

^a The tolerances for the out-of-roundness are rounded values obtained from those in ISO 11922-1:1997, grade M, by multiplying by 0,25 (see ISO 727-1).

^b The minimum socket length is equal to $(0,5d_n + 5)$ mm (see ISO 727-1).

A.3.3.2.3 Socket taper

The maximum included angle of the socket portion of a fitting shall not exceed $0^\circ 40'$ for $d_n \leq 63$ mm and $0^\circ 30'$ for $d_n \geq 75$ mm.

A.3.3.2.4 Other dimensions

Other dimensions of sockets for solvent cementing shall be as specified by the manufacturer.

A.3.3.3 Flange adaptors and loose backing flanges

A.3.3.3.1 Dimensions of flange adaptors for solvent cementing

The dimensions of flange adaptors for solvent cementing (see Figure A.3) shall be as specified in Table A.5.

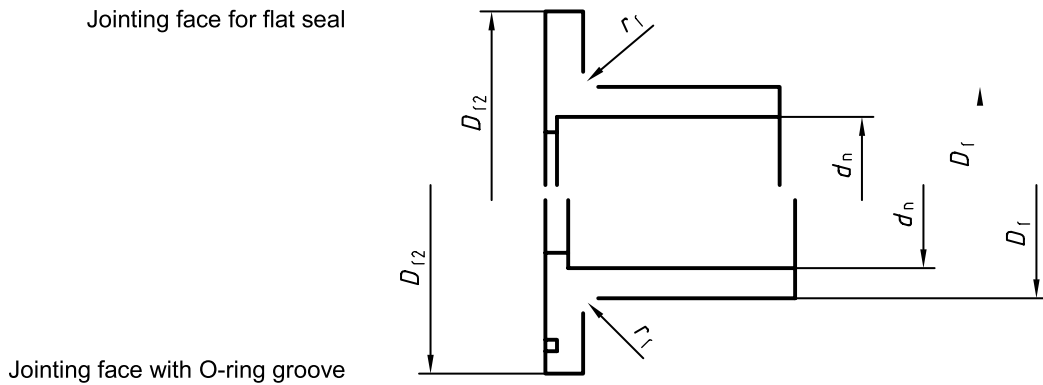

Figure A.3 — Dimensions of flange adaptors for solvent cementing

Table A.5 — Dimensions of flange adaptors for solvent cementing

Dimensions in millimetres

Nominal outside diameter of corresponding pipe d_n	Outside diameter of chamfer on shoulder D_{f1}	Outside diameter of flange adaptor D_{f2}	Radius of chamfer on shoulder r_f
16	22	29	1
20	27	34	1
25	33	41	1,5
32	41	50	1,5
40	50	61	2
50	61	73	2
63	76	90	2,5
75	90	106	2,5
90	108	125	3
110	131	150	3
125	148	170	3
140	165	188	4
160	188	213	4
180	201	247	4
200	224	250	4
225	248	274	4
250	274	303	4
280	308	329	4
315	346	379	4
355	384	430	5
400	438	482	5

A.3.3.3.2 Dimensions of loose backing flanges for use with flange adaptors for solvent cementing

The dimensions of loose backing flanges for use with flange adaptors for solvent cementing (see Figure A.4) shall be as specified in Table A.6.

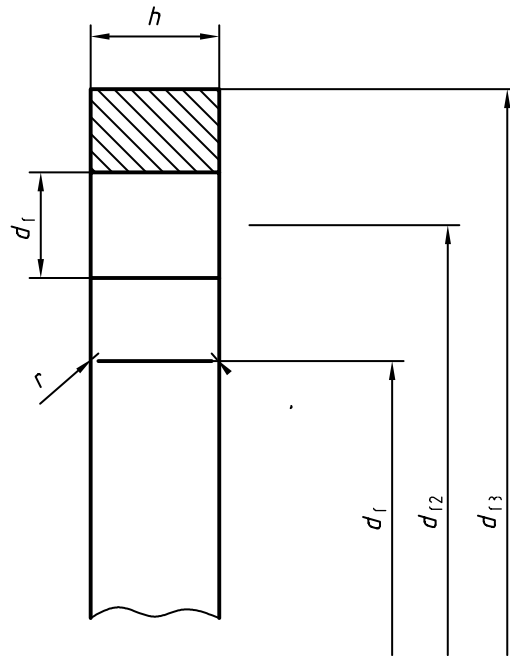

NOTE The thickness, h , of the loose backing flange is dependent on the material used.

Figure A.4 — Dimensions of loose backing flanges for use with flange adaptors for solvent cementing

Table A.6 — Dimensions of loose backing flanges for use with flange adaptors for solvent cementing

Dimensions in millimetres

Nominal outside diameter of corresponding pipe d_n	Nominal size of flange DN	Inside diameter of flange d_{f1}	Pitch circle diameter of bolt holes d_{f2}	Outside diameter of flange d_{f3} min.	Diameter of bolt holes d_{f4}	Radius of flange r	Number of bolt holes	Metric thread of bolt
16	10	23	60	90	14	1	4	M12
20	15	28	65	95	14	1	4	M12
25	20	34	75	105	14	1,5	4	M12
32	25	42	85	115	14	1,5	4	M12
40	32	51	100	140	18	2	4	M16
50	40	62	110	150	18	2	4	M16
63	50	78	125	165	18	2,5	4	M16
75	65	92	145	185	18	2,5	4	M16
90	80	110	160	200	18	3	8	M16
110	100	133	180	220	18	3	8	M16
125	125	150	210	250	18	3	8	M16
140	125	167	210	250	18	4	8	M16
160	150	190	240	285	22	4	8	M20
180	175	203	240	315	22	4	8	M20
200	200	226	295	340	22	4	8	M20
225	200	250	295	340	22	4	8	M20
250	250	277	325	370	22	4	8	M20
280	250	310	350	395	22	4	12	M20
315	300	348	400	445	22	4	12	M20
355	350	388	460	505	22	5	16	M20
400	400	442	515	565	26	5	16	M24

A.4 Mechanical characteristics

A.4.1 Mechanical characteristics of pipes and fittings

A.4.1.1 Resistance to internal pressure of pipes and fittings

When tested as specified in Table A.7 under the test conditions indicated, using the test set-up indicated in Table A.8, components shall withstand the hydrostatic stress without bursting or leakage.

NOTE The internal pressure to be used is calculated as indicated in 8.2.

Table A.7 — Requirements for internal-pressure testing

Characteristic	Requirement	Test conditions		Test method ^a
		Hydrostatic (hoop) stress MPa	Time h	
Resistance to internal pressure at 20 °C	No failure during test period	25,0	≥ 1	ISO 1167 ISO 12092
Resistance to internal pressure at 20 °C		20,6	≥ 100	ISO 1167 ISO 12092
Resistance to internal pressure at 60 °C		7,0	≥ 1 000	ISO 1167 ISO 12092

^a Fittings shall be prepared in accordance with ISO 12092 and tested in accordance with ISO 1167.

Table A.8 — Test set-up

End caps	Type A as specified in ISO 1167:1996
Orientation	Not specified
Conditioning period	≥ 1 h
Type of test	Water-in-water or water-in-air ^a

^a In cases of dispute, water-in-water shall be used.

A.4.1.2 Resistance to impact of pipes

When tested in accordance with ISO 3127 for resistance to external blows at 0 °C, pipes shall have a true impact rate (TIR) of not more than 10 % when using the falling weights and fall heights given in Table A.9.

NOTE For practical reasons, this test is not relevant to pipes with $d_n < 20$ mm.

Table A.9 — Requirements for impact testing of pipes

Nominal outside diameter d_n mm	Mass of falling weight kg	Fall height of falling weight m
20	0,5	2,0
25	1,5	2,0
32	1,6	2,0
40	2,0	2,0
50	2,5	2,0
63	4	2,0
75	4	2,0
90	5	2,0
110	6	2,0
125	6	2,0
140	6	2,0
160	7	2,0
180	7	2,0
200	8	2,0
≥ 225	9	2,0

A.4.2 Mechanical characteristics of valves

Valves shall conform to the requirements of ISO 16135, ISO 16136, ISO 16137, ISO 16138, ISO 16139 or ISO 21787, as applicable, depending on the valve type.

A.5 Physical characteristics

A.5.1 Physical characteristics of pipes

When determined in accordance with the test methods specified in Table A.10, using the parameters indicated, the physical characteristics of pipes shall conform to the requirements given in Table A.10.

Table A.10 — Physical characteristics of pipes

Characteristic	Requirement	Test parameters		Test method
Vicat softening temperature (VST/B/50 N)	VST \geq 90 °C	Conditioning	6 h in air at 80 °C	ISO 306
	and			
	VST \geq 70 °C	Conditioning	16 h in water at 90 °C	
Longitudinal reversion ^a	\leq 5 % ^b The pipe shall exhibit no bubbles or cracks	Temperature	150 °C	ISO 2505-1:1994 together with ISO 2505-2:1994 Method A: Liquid bath
		Immersion time:		
		$e \leq$ 8 mm	15 min	
		8 mm < $e \leq$ 16 mm	30 min	
$e >$ 16 mm	60 min			
Length of test piece	200 mm			
or				
		Temperature	150 °C	ISO 2505-1:1994 together with ISO 2505-2:1994 Method B: Air
		Immersion time:		
		$e \leq$ 8 mm	60 min	
		8 mm < $e \leq$ 16 mm	120 min	
		$e >$ 16 mm	240 min	
		Length of test piece	200 mm	
^a The choice between method A and method B is free. In cases of dispute, however, method A shall be used.				
^b For nominal outside diameters \leq 50 mm, a higher value may be found. This value shall not exceed 10 %, however.				

A.5.2 Physical characteristics of fittings

When determined in accordance with the test method specified in Table A.11, using the parameters indicated, the physical characteristics of fittings shall conform to the requirements given in Table A.11.

Table A.11 — Physical characteristics of fittings

Characteristic	Requirement	Test parameters		Test method
Vicat softening temperature (VST/B/50 N)	VST \geq 90 °C	Conditioning	6 h in air at 80 °C	ISO 306
	and			
	VST \geq 70 °C	Conditioning	16 h in water at 90 °C	

A.5.3 Physical characteristics of valves

In addition to the requirements of ISO 16135, ISO 16136, ISO 16137, ISO 16138, ISO 16139 or ISO 21787, as applicable, depending on the valve type, valves shall conform to A.5.2.

A.6 Fitness for purpose of the system

The fitness for purpose of the system shall be deemed to apply when test assemblies, assembled in accordance with 12.2 and tested using the test methods and parameters specified in Table A.12, conform to the requirements given in Table A.12.

Table A.12 — General requirements for fitness for purpose of the system

Characteristic	Requirement	Test parameters		Test method
Hydrostatic strength at 20 °C	No failure during test period	End caps	Type A as specified in ISO 1167:1996	ISO 1167 and ISO 12092 ^a
		Orientation	Not specified	
		Test temperature	20 °C	
		Type of test	Water-in-water or water-in-air ^b	
		Hydrostatic (hoop) stress	15,6 MPa	
		Minimum conditioning period after solvent cementing	1 day at 20 °C and 5 days at 60 °C	
		Conditioning period	≥ 1 h	
		Test period	≥ 1 000 h	
^a Assemblies of pipes and fittings shall be prepared in accordance with ISO 12092 and tested in accordance with ISO 1167.				
^b In cases of dispute, water-in-water shall be used.				

Annex B (normative)

Specific characteristics and requirements for industrial piping systems made from unplasticized poly(vinyl chloride) (PVC-U)

B.1 Material

B.1.1 Material for components

The material shall be tested in accordance with 5.2 at 20 °C, 40 °C and 60 °C as well as at various hydrostatic (hoop) stresses in such a way that, at each temperature, at least three failure times fall in each of the following time intervals:

- 10 h to 100 h;
- 100 h to 1 000 h;
- 1 000 h to 8 760 h;
- > 8 760 h.

In tests lasting more than 8 760 h, any time reached which corresponds to a point on or above the relevant reference curve may be considered as a failure time.

The values of the minimum required hydrostatic strength (see reference curves given in Figure B.1) in the temperature range of 20 °C to 60 °C were calculated using the following equation:

$$\log t = -164,461 - 29\,349,493 \times \frac{\log \sigma}{T} + 60\,126,534 \times \frac{1}{T} + 75,079 \times \log \sigma \quad (\text{B.1})$$

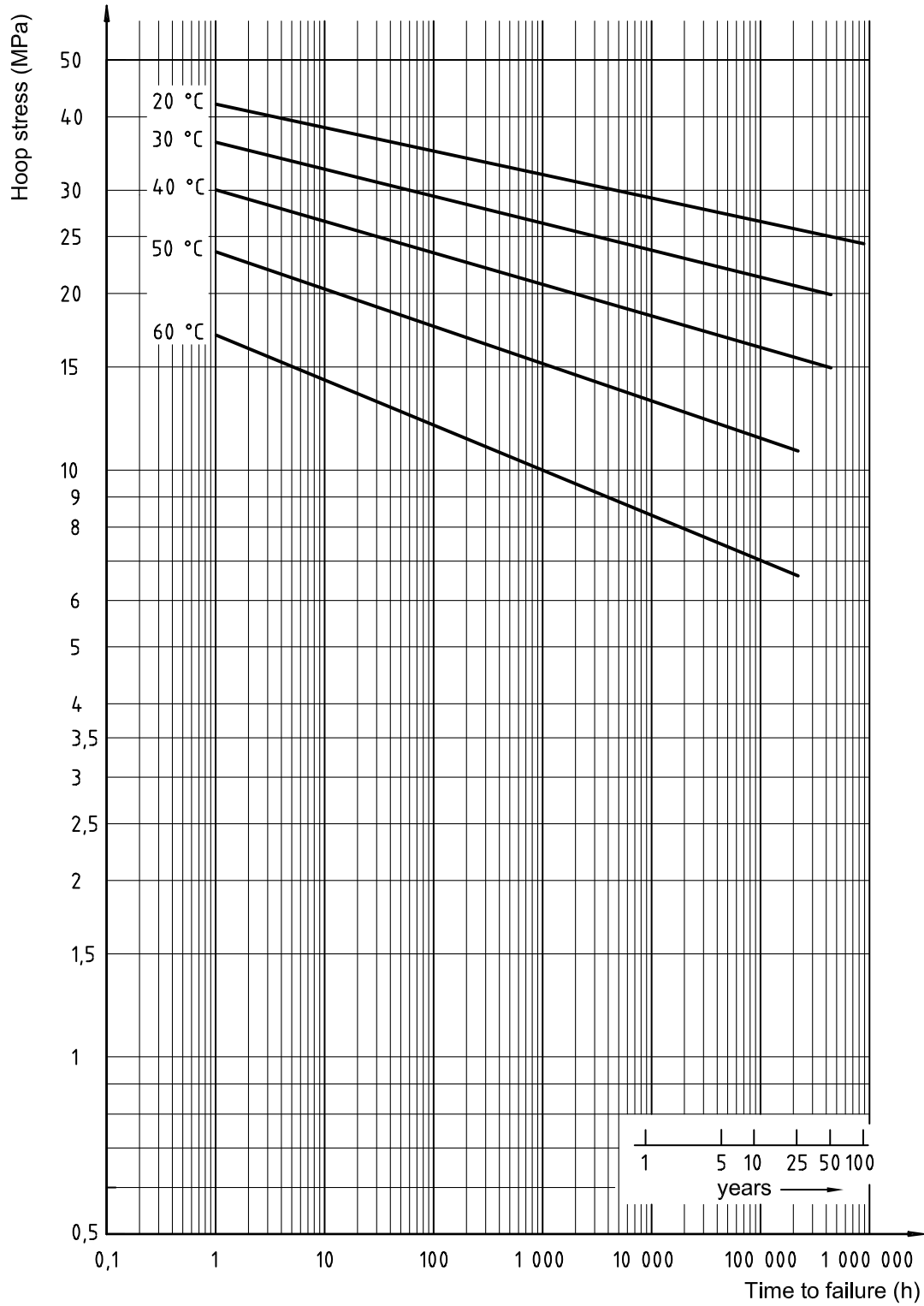

Figure B.1 — Minimum required hydrostatic strength curves for PVC-U

B.1.2 MRS-value

When evaluated in accordance with 5.2, PVC-U material shall have an MRS at least equal to 25,0 MPa.

B.1.3 Density of material

The density of the material from which the components are manufactured shall conform to the requirement given in Table A.1.

Table B.1 — Density of ABS material

Characteristic	Requirement ^a	Test temperature	Test method
Density, ρ (kg/m ³)	$1\,330 \leq \rho \leq 1\,460$	23 °C	ISO 1183-2
^a Conformity to this requirement shall be declared by the raw-material producer.			

B.2 General characteristics — Colour

Components made from PVC-U should preferably be grey. Other colours shall be agreed on between manufacturer and purchaser.

B.3 Geometrical characteristics

B.3.1 Dimensions of pipes

B.3.1.1 Diameters and associated tolerances

The mean outside diameter, d_{em} , determined as the average value of measurements made at distances of d_n and $0,1d_n$ from the end of the test piece, shall be as specified in Table B.2.

B.3.1.2 Out-of-roundness

The out-of-roundness, measured at the point of manufacture, shall be as specified in Table B.2. If values for the out-of-roundness other than those given in Table B.2 are necessary, they shall be agreed on between manufacturer and purchaser.

Table B.2 — Mean outside diameters, associated tolerances and out-of-roundness of pipes

Dimensions in millimetres

Nominal outside diameter d_n	Mean outside diameter d_{em} min.	Tolerance on outside diameter ^a	Out-of-roundness	
			S 20 to S 16 ^b max.	S 12,5 to S 5 ^c max.
12	12,0	+ 0,2	—	0,5
16	16,0	+ 0,2	—	0,5
20	20,0	+ 0,2	—	0,5
25	25,0	+ 0,2	—	0,5
32	32,0	+ 0,2	—	0,5
40	40,0	+ 0,2	1,4	0,5
50	50,0	+ 0,2	1,4	0,6
63	63,0	+ 0,3	1,5	0,8
75	75,0	+ 0,3	1,6	0,9
90	90,0	+ 0,3	1,8	1,1
110	110,0	+ 0,4	2,2	1,4
125	125,0	+ 0,4	2,5	1,5
140	140,0	+ 0,5	2,8	1,7
160	160,0	+ 0,5	3,2	2,0
180	180,0	+ 0,6	3,6	2,2
200	200,0	+ 0,6	4,0	2,4
225	225,0	+ 0,7	4,5	2,7
250	250,0	+ 0,8	5,0	3,0
280	280,0	+ 0,9	6,8	3,4
315	315,0	+ 1,0	7,6	3,8
355	355,0	+ 1,1	8,6	4,3
400	400,0	+ 1,2	9,6	4,8

^a The tolerances correspond to Grade D of ISO 11922-1:1997 for $d_n \leq 50$ mm and to Grade C of ISO 11922-1:1997 for $d_n > 50$ mm.

^b The tolerances correspond to Grade N of ISO 11922-1:1997 for $d_n \leq 250$ mm and to Grade M of ISO 11922-1:1997 for $d_n > 250$ mm.

^c The tolerances correspond to $0,5 \times$ Grade M of ISO 11922-1:1997.

B.3.1.3 Wall thicknesses and associated tolerances

The wall thickness, e , and the associated tolerance shall be as specified in Table B.3.

Table B.3 — Wall thicknesses and associated tolerances

Dimensions in millimetres

Nominal outside diameter d_n	Wall thickness, e , and associated tolerance ^a													
	Pipe series S and standard dimension ratio SDR													
	S 20 SDR 41		S 16 SDR 33		S 12,5 SDR 26		S 10 SDR 21		S 8 SDR 17		S 6,3 SDR 13,6		S 5 SDR 11	
	e min.	b	e min.	b	e min.	b	e min.	b	e min.	b	e min.	b	e min.	b
12	—	—	—	—	—	—	—	—	—	—	—	—	1,5	+ 0,4
16	—	—	—	—	—	—	—	—	—	—	—	—	1,5	+ 0,4
20	—	—	—	—	—	—	—	—	—	—	1,5	+ 0,4	1,9	+ 0,4
25	—	—	—	—	—	—	—	—	1,5	+ 0,4	1,9	+ 0,4	2,3	+ 0,5
32	—	—	—	—	1,5	+ 0,4	1,6	+ 0,4	1,9	+ 0,4	2,4	+ 0,5	2,9	+ 0,5
40	—	—	1,5	+ 0,4	1,6	+ 0,4	1,9	+ 0,4	2,4	+ 0,5	3,0	+ 0,5	3,7	+ 0,6
50	—	—	1,6	+ 0,4	2,0	+ 0,4	2,4	+ 0,5	3,0	+ 0,5	3,7	+ 0,6	4,6	+ 0,7
63	—	—	2,0	+ 0,4	2,5	+ 0,5	3,0	+ 0,5	3,8	+ 0,6	4,7	+ 0,7	5,8	+ 0,8
75	—	—	2,3	+ 0,5	2,9	+ 0,5	3,6	+ 0,6	4,5	+ 0,7	5,6	+ 0,8	6,8	+ 0,9
90	—	—	2,8	+ 0,5	3,5	+ 0,6	4,3	+ 0,7	5,4	+ 0,8	6,7	+ 0,9	8,2	+ 1,1
110	2,7	+ 0,5	3,4	+ 0,6	4,2	+ 0,7	5,3	+ 0,8	6,6	+ 0,9	8,1	+ 1,1	10,0	+ 1,2
125	3,1	+ 0,6	3,9	+ 0,6	4,8	+ 0,7	6,0	+ 0,8	7,4	+ 1,0	9,2	+ 1,2	11,4	+ 1,4
140	3,5	+ 0,6	4,3	+ 0,7	5,4	+ 0,8	6,7	+ 0,9	8,3	+ 1,1	10,3	+ 1,3	12,7	+ 1,5
160	4,0	+ 0,6	4,9	+ 0,7	6,2	+ 0,9	7,7	+ 1,0	9,5	+ 1,2	11,8	+ 1,4	14,6	+ 1,7
180	4,4	+ 0,7	5,5	+ 0,8	6,9	+ 0,9	8,6	+ 1,1	10,7	+ 1,3	13,3	+ 1,6	16,4	+ 1,9
200	4,9	+ 0,7	6,2	+ 0,9	7,7	+ 1,0	9,6	+ 1,2	11,9	+ 1,4	14,7	+ 1,7	18,2	+ 2,1
225	5,5	+ 0,8	6,9	+ 0,9	8,6	+ 1,1	10,8	+ 1,3	13,4	+ 1,6	16,6	+ 1,9	—	—
250	6,2	+ 0,9	7,7	+ 1,0	9,6	+ 1,2	11,9	+ 1,4	14,8	+ 1,7	18,4	+ 2,1	—	—
280	6,9	+ 0,9	8,6	+ 1,1	10,7	+ 1,3	13,4	+ 1,6	16,6	+ 1,9	20,6	+ 2,3	—	—
315	7,7	+ 1,0	9,7	+ 1,2	12,1	+ 1,5	15,0	+ 1,7	18,7	+ 2,1	23,2	+ 2,6	—	—
355	8,7	+ 1,1	10,9	+ 1,3	13,6	+ 1,6	16,9	+ 1,9	21,1	+ 2,4	26,1	+ 2,9	—	—
400	9,8	+ 1,2	12,3	+ 1,5	15,3	+ 1,8	19,1	+ 2,2	23,7	+ 2,6	29,4	+ 3,2	—	—

NOTE For safety reasons, the minimum wall thickness should not be less than 1,5 mm.

^a All dimensions correspond to those given in ISO 4065.

^b The tolerances have been calculated from the expression $(0,1e + 0,2)$ mm and rounded up to the nearest 0,1 mm.

B.3.2 Dimensions of sockets for solvent cementing

The dimensions of sockets for solvent cementing (see Figure B.2) shall be as specified in Table B.4.

B.3.3 Dimensions of fittings

B.3.3.1 General

This annex is applicable to the following types of fittings:

- fittings for solvent cementing;
- flange adaptors and loose backing flanges;
- mechanical fittings.

B.3.3.2 Fittings for solvent cementing

B.3.3.2.1 Nominal diameter(s)

The nominal diameter(s), d_n , of a fitting for solvent cementing shall correspond to, and be designated by, the nominal outside diameter(s) of the pipe(s) for which the fitting is designed.

B.3.3.2.2 Diameters and lengths of sockets

The diameters and lengths of sockets for solvent cementing (see Figure B.2) shall be as specified in Table B.4.

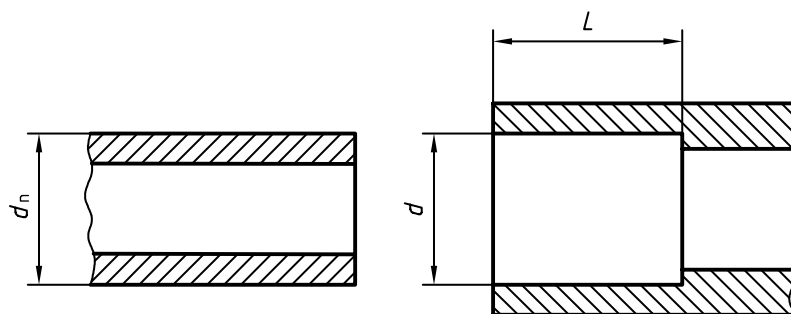

Key

- d_n nominal outside diameter
- d_i inside diameter of socket at midpoint of socket length
- L length of socket, i.e. distance from socket mouth to shoulder, if any

Figure B.2 — Diameters and lengths of sockets for solvent cementing

Table B.4 — Diameters and lengths of sockets for solvent cementing

Dimensions in millimetres

Nominal outside diameter of pipe d_n	Mean inside diameter of socket d_{im}		Out-of-roundness ^a max.	Socket length ^b L min.
	min.	max.		
12	12,1	12,3	0,25	12,0
16	16,1	16,3	0,25	14,0
20	20,1	20,3	0,25	16,0
25	25,1	25,3	0,25	18,5
32	32,1	32,3	0,25	22,0
40	40,1	40,3	0,25	26,0
50	50,1	50,3	0,3	31,0
63	63,1	63,3	0,4	37,5
75	75,1	75,3	0,5	43,5
90	90,1	90,3	0,6	51,0
110	110,1	110,4	0,7	61,0
125	125,1	125,4	0,8	68,5
140	140,2	140,5	0,9	76,0
160	160,2	160,5	1,0	86,0
180	180,2	180,6	1,1	96,0
200	200,2	200,6	1,2	106,0
225	225,3	225,7	1,4	118,5
250	250,3	250,8	1,5	131,0
280	280,3	280,9	1,7	146,0
315	315,4	316,0	1,9	163,5
355	355,5	356,2	2,2	183,5
400	400,5	401,5	2,4	206,0

^a The tolerances for the out-of-roundness are rounded values obtained from those in ISO 11922-1:1997, grade M, by multiplying by 0,25 (see ISO 727-1).

^b The minimum socket length is equal to $(0,5d_n + 5)$ mm (see ISO 727-1).

B.3.3.2.3 Socket taper

The maximum included angle of the socket portion of a fitting shall not exceed 0° 40' for $d_n \leq 63$ mm and 0° 30' for $d_n \geq 75$ mm.

B.3.3.2.4 Other dimensions

Other dimensions of sockets for solvent cementing shall be as specified by the manufacturer.

B.3.3.3 Flange adaptors and loose backing flanges

B.3.3.3.1 Dimensions of flange adaptors for solvent cementing

The dimensions of flange adaptors for solvent cementing (see Figure B.3) shall be as specified in Table B.5.

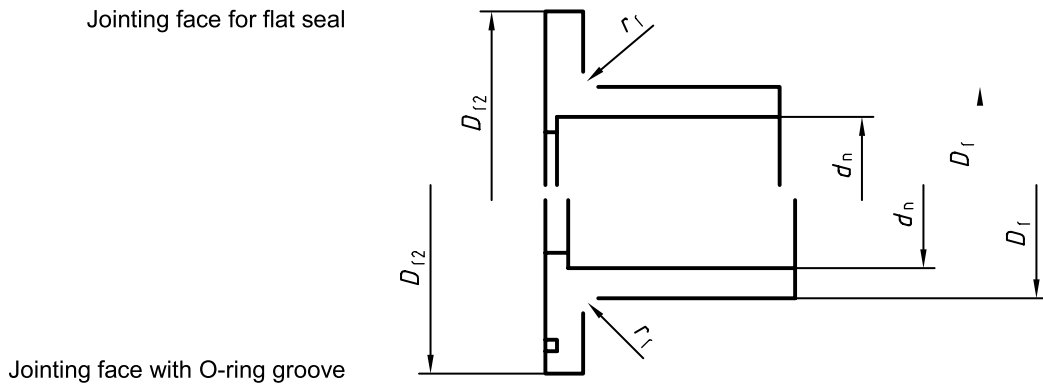

Figure B.3 — Dimensions of flange adaptors for solvent cementing

Table B.5 — Dimensions of flange adaptors for solvent cementing

Dimensions in millimetres

Nominal outside diameter of corresponding pipe	Outside diameter of chamfer on shoulder	Outside diameter of flange adaptor	Radius of chamfer on shoulder
d_n	D_{f1}	D_{f2}	r_f
16	22	29	1
20	27	34	1
25	33	41	1,5
32	41	50	1,5
40	50	61	2
50	61	73	2
63	76	90	2,5
75	90	106	2,5
90	108	125	3
110	131	150	3
125	148	170	3
140	165	188	4
160	188	213	4
180	201	247	4
200	224	250	4
225	248	274	4
250	274	303	4
280	308	329	4
315	346	379	4
355	384	430	5
400	438	482	5

B.3.3.3.2 Dimensions of loose backing flanges for use with flange adaptors for solvent cementing

The dimensions of loose backing flanges for use with flange adaptors for solvent cementing (see Figure B.4) shall be as specified in Table B.6.

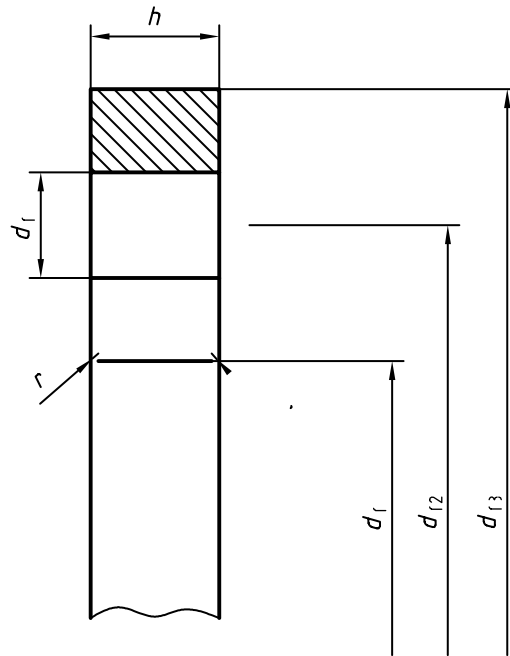

NOTE The thickness, h , of the loose backing flange is dependent on the material used.

Figure B.4 — Dimensions of loose backing flanges for use with flange adaptors for solvent cementing

Table B.6 — Dimensions of loose backing flanges for use with flange adaptors for solvent cementing

Dimensions in millimetres

Nominal outside diameter of corresponding pipe d_n	Nominal size of flange DN	Inside diameter of flange d_{f1}	Pitch circle diameter of bolt holes d_{f2}	Outside diameter of flange d_{f3} min.	Diameter of bolt holes d_{f4}	Radius of flange r	Number of bolt holes	Metric thread of bolt
16	10	23	60	90	14	1	4	M12
20	15	28	65	95	14	1	4	M12
25	20	34	75	105	14	1,5	4	M12
32	25	42	85	115	14	1,5	4	M12
40	32	51	100	140	18	2	4	M16
50	40	62	110	150	18	2	4	M16
63	50	78	125	165	18	2,5	4	M16
75	65	92	145	185	18	2,5	4	M16
90	80	110	160	200	18	3	8	M16
110	100	133	180	220	18	3	8	M16
125	125	150	210	250	18	3	8	M16
140	125	167	210	250	18	4	8	M16
160	150	190	240	285	22	4	8	M20
180	175	203	240	315	22	4	8	M20
200	200	226	295	340	22	4	8	M20
225	200	250	295	340	22	4	8	M20
250	250	277	325	370	22	4	8	M20
280	250	310	350	395	22	4	12	M20
315	300	348	400	445	22	4	12	M20
355	350	388	460	505	22	5	16	M20
400	400	442	515	565	26	5	16	M24

B.4 Mechanical characteristics

B.4.1 Mechanical characteristics of pipes and fittings

B.4.1.1 Resistance to internal pressure of pipes and fittings

When tested as specified in Table B.7 under the test conditions indicated, using the test set-up indicated in Table B.8, components shall withstand the hydrostatic stress without bursting or leakage.

NOTE The internal pressure to be used is calculated as indicated in 8.2.

Table B.7 — Requirements for internal-pressure testing

Characteristic	Requirement	Test conditions		Test method ^a
		Hydrostatic (hoop) stress MPa	Time h	
Resistance to internal pressure at 20 °C	No failure during test period	42,0	≥ 1	ISO 1167 ISO 12092
Resistance to internal pressure at 20 °C		35,0	≥ 100	ISO 1167 ISO 12092
Resistance to internal pressure at 20 °C		32,0	≥ 1 000	ISO 1167 ISO 12092
Resistance to internal pressure at 60 °C		10,0	≥ 1 000	ISO 1167 ISO 12092

^a Fittings shall be prepared in accordance with ISO 12092 and tested in accordance with ISO 1167.

Table B.8 — Test set-up

End caps	Type A as specified in ISO 1167:1996
Orientation	Not specified
Conditioning period	≥ 1 h
Type of test	Water-in-water or water-in-air ^a

^a In cases of dispute, water-in-water shall be used.

B.4.1.2 Resistance to impact of pipes

When tested in accordance with ISO 3127 for resistance to external blows at 0 °C, pipes with a nominal wall thickness $e_n \leq 14,9$ mm shall have a true impact rate (TIR) of not more than 10 % when using the falling weights and fall heights given in Table B.9 for the relevant level (see below).

Pipes of pipe series S 5 to S 10 shall be tested at the medium level, M. Pipes of pipe series S 12,5 to S 20 shall be tested at the high level, H.

NOTE For practical reasons, this test is not relevant to pipes with $d_n < 20$ mm.

Table B.9 — Requirements for impact testing of pipes

Nominal outside diameter d_n mm	Medium level, M		High level, H	
	Mass of falling weight kg	Fall height of falling weight m	Mass of falling weight kg	Fall height of falling weight m
20	0,5	0,4	0,5	0,4
25	0,5	0,5	0,5	0,5
32	0,5	0,6	0,5	0,6
40	0,5	0,8	0,5	0,8
50	0,5	1,0	0,5	1,0
63	0,8	1,0	0,8	1,0
75	0,8	1,0	0,8	1,2
90	0,8	1,2	1,0	2,0
110	1,0	1,6	1,6	2,0
125	1,25	2,0	2,5	2,0
140	1,6	1,8	3,2	1,8
160	1,6	2,0	3,2	2,0
180	2,0	1,8	4,0	1,8
200	2,0	2,0	4,0	2,0
225	2,5	1,8	5,0	1,8
250	2,5	2,0	5,0	2,0
280	3,2	1,8	6,3	1,8
≥ 315	3,2	2,0	6,3	2,0

B.4.1.3 Resistance to crushing of fittings

When injection-moulded parts of fittings, to which hydraulic pressure cannot be applied, are tested in accordance with ISO 9853, the tested fitting parts shall not shatter when a deformation of 20 % is applied.

The period between manufacture and testing and the conditioning period shall not be less than 30 min. The closure speed of the press plates shall be (50 ± 5) mm/min.

B.4.2 Mechanical characteristics of valves

Valves shall conform to the requirements of ISO 16135, ISO 16136, ISO 16137, ISO 16138, ISO 16139 or ISO 21787, as applicable, depending on the valve type.

B.5 Physical characteristics

B.5.1 Physical characteristics of pipes

When determined in accordance with the test methods specified in Table B.10, using the parameters indicated, the physical characteristics of pipes shall conform to the requirements given in Table B.10.

Table B.10 — Physical characteristics of pipes

Characteristic	Requirement	Test parameters		Test method
Vicat softening temperature	$VST \geq 80 \text{ }^\circ\text{C}$	As specified in ISO 2507-2		ISO 2507-1
Longitudinal reversion ^a	$\leq 5 \%$ The pipe shall exhibit no bubbles or cracks	Temperature	150 °C	ISO 2505-1:1994 together with ISO 2505-2:1994 Method A: Liquid bath
		Immersion time:		
		$e \leq 8 \text{ mm}$	15 min	
		$8 \text{ mm} < e \leq 16 \text{ mm}$	30 min	
		$e > 16 \text{ mm}$	60 min	
		Length of test piece	200 mm	
		or		
		Temperature	150 °C	ISO 2505-1:1994 together with ISO 2505-2:1994 Method B: Air
		Immersion time:		
		$e \leq 8 \text{ mm}$	60 min	
		$8 \text{ mm} < e \leq 16 \text{ mm}$	120 min	
		$e > 16 \text{ mm}$	240 min	
		Length of test piece	200 mm	
Resistance to dichloromethane at specified temperature	No attack at any part of surface of test piece	Temperature of bath	15 °C	ISO 9852
		Immersion time	30 min	
WARNING — Attention is drawn to the dangers involved in using dichloromethane (for details, see ISO 9852).				
^a The choice between method A or method B is free. In cases of dispute, however, method A shall be used.				

B.5.2 Physical characteristics of fittings

B.5.2.1 General

When determined in accordance with the test methods specified in Table B.11, using the parameters indicated, the physical characteristics of fittings shall conform to the requirements given in Table B.11.

Table B.11 — Physical characteristics of fittings

Characteristic	Requirement	Test parameters		Test method
Vicat softening temperature	VST \geq 74 °C	As specified in ISO 2507-2		ISO 2507-1
Effects of heating	The fittings shall not exhibit any blisters or signs of weld-line splitting ^a No surface damage in the area of any injection point shall penetrate by more than 30 % of the wall thickness at that point. Outside the area of any injection point, no surface damage shall occur. ^b	Temperature Immersion time: $e \leq 3$ mm $3 \text{ mm} < e \leq 10$ mm $10 \text{ mm} < e \leq 20$ mm $20 \text{ mm} < e \leq 30$ mm $30 \text{ mm} < e \leq 40$ mm $e > 40$ mm Examination of test pieces after heating	150 °C 15 min 30 min 60 min 140 min 220 min 240 min See B.5.2.2	ISO 580:— Air-oven method

^a The weld-line is likely to become more pronounced, but this shall not be taken as a sign of weld-line opening.

^b For sprue-gating, the area of the injection point shall be calculated using a radius, R , of $0,3d_n$, with a maximum value of 50 mm. For fittings moulded by end-gating techniques, e.g. ring or diaphragm methods, the gating area shall be a cylindrical portion with a length, L_1 , of $0,3d_n$, with a maximum value of 50 mm (see Figure B.5). Any cracks or delamination in the wall of the fitting adjacent to the injection area, parallel to the axis of the fitting, shall not penetrate in the axial direction by more than 20 % of the length L_1 given above.

B.5.2.2 Effects of heating — Examination of test pieces

After removal from the air oven, the test pieces shall be cut, using a razor-sharp blade, from the mouth of the socket or spigot end of the fitting over its full length and the exposed surfaces examined.

The number of cuts made on each test piece shall be as follows:

- For fittings of $d_n \leq 160$ mm:
not less than two cuts equally spaced around the periphery of the mouth of each socket or spigot end of the fitting.
- For fittings of $d_n > 160$ mm:
not less than four cuts equally spaced around the periphery of the mouth of each socket or spigot end of the fitting.

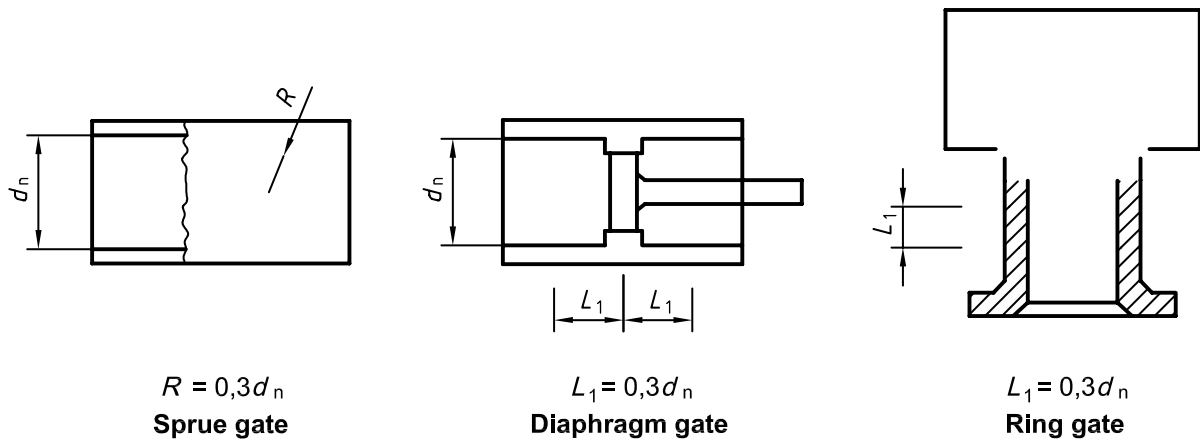

Figure B.5 — Injection gating areas

B.5.3 Physical characteristics of valves

In addition to the requirements of ISO 16135, ISO 16136, ISO 16137, ISO 16138, ISO 16139 or ISO 21787, as applicable, depending on the valve type, valves shall conform to the requirements of B.5.2.

B.6 Fitness for purpose of the system

The fitness for purpose of the system shall be deemed to apply when test assemblies, assembled in accordance with 12.2 and tested using the test methods and parameters specified in Table B.12, conform to the requirements given in Table B.12.

Table B.12 — General requirements for fitness for purpose of the system

Characteristic	Requirement	Test parameters		Test method ^a
Hydrostatic strength at 20 °C	No failure during test period	End caps	Type A as specified in ISO 1167:1996	ISO 1167 and ISO 12092
		Orientation	Not specified	
		Test temperature	20 °C	
		Type of test	Water-in-water	
		Hydrostatic (hoop) stress	16,8 MPa	
		Conditioning period	≥ 1 h	
		Test period	≥ 1 000 h	
Hydrostatic strength at 60 °C	No failure during test period	End caps	Type A as specified in ISO 1167:1996	ISO 1167 and ISO 12092
		Orientation	Not specified	
		Test temperature	60 °C	
		Type of test	Water-in-water	
		Hydrostatic (hoop) stress	6,1 MPa	
		Conditioning period	≥ 1 h	
		Test period	≥ 1 000 h	

^a Assemblies of pipes and fittings shall be prepared in accordance with ISO 12092 and tested in accordance with ISO 1167.

Annex C (normative)

Specific characteristics and requirements for industrial piping systems made from chlorinated poly(vinyl chloride) (PVC-C)

C.1 Material

C.1.1 Material for pipes

The material shall be tested in accordance with 5.2 at 20 °C, 60 °C to 82 °C and 95 °C as well as at various hydrostatic (hoop) stresses in such a way that, at each temperature, at least three failure times fall in each of the following time intervals:

- 10 h to 100 h;
- 100 h to 1 000 h;
- 1 000 h to 8 760 h;
- > 8 760 h.

In tests lasting more than 8 760 h, any time reached which corresponds to a point on or above the relevant reference curve may be considered as a failure time.

The values of the minimum required hydrostatic strength (see reference curves given in Figure C.1) in the temperature range of 10 °C to 95 °C were calculated using the following equation:

$$\log t = -109,95 - 21\,897,4 \times \frac{\log \sigma}{T} + 43\,702,87 \times \frac{1}{T} + 50,742\,02 \times \log \sigma \quad (\text{C.1})$$

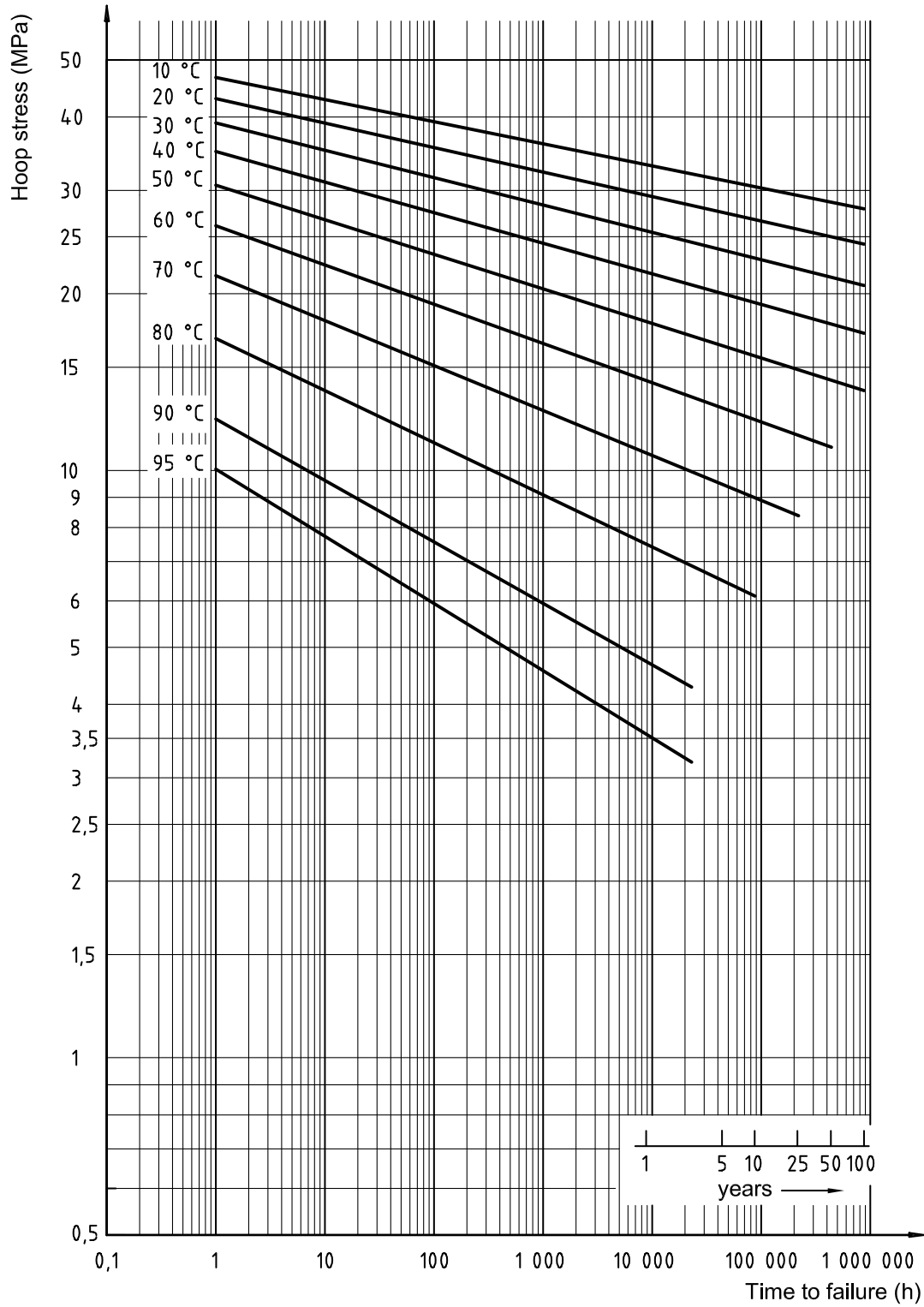

Figure C.1 — Minimum required hydrostatic strength curves for PVC-C pipe material

C.1.2 Material for fittings

The material shall be tested in accordance with 5.2 at 20 °C, 60 °C to 82 °C and 90 °C as well as at various hydrostatic (hoop) stresses in such a way that, at each temperature, at least three failure times fall in each of the following time intervals:

- 10 h to 100 h;
- 100 h to 1 000 h;
- 1 000 h to 8 760 h;
- > 8 760 h.

In tests lasting more than 8 760 h, any time reached which corresponds to a point on or above the relevant reference curve may be considered as a failure time.

The values of the minimum required hydrostatic strength (see reference curves given in Figure C.2) in the temperature range of 10 °C to 90 °C were calculated using the following equation:

$$\log t = -121,699 - 25\,985 \times \frac{\log \sigma}{T} + 47\,143,18 \times \frac{1}{T} + 63,035\,11 \times \log \sigma \quad (\text{C.2})$$

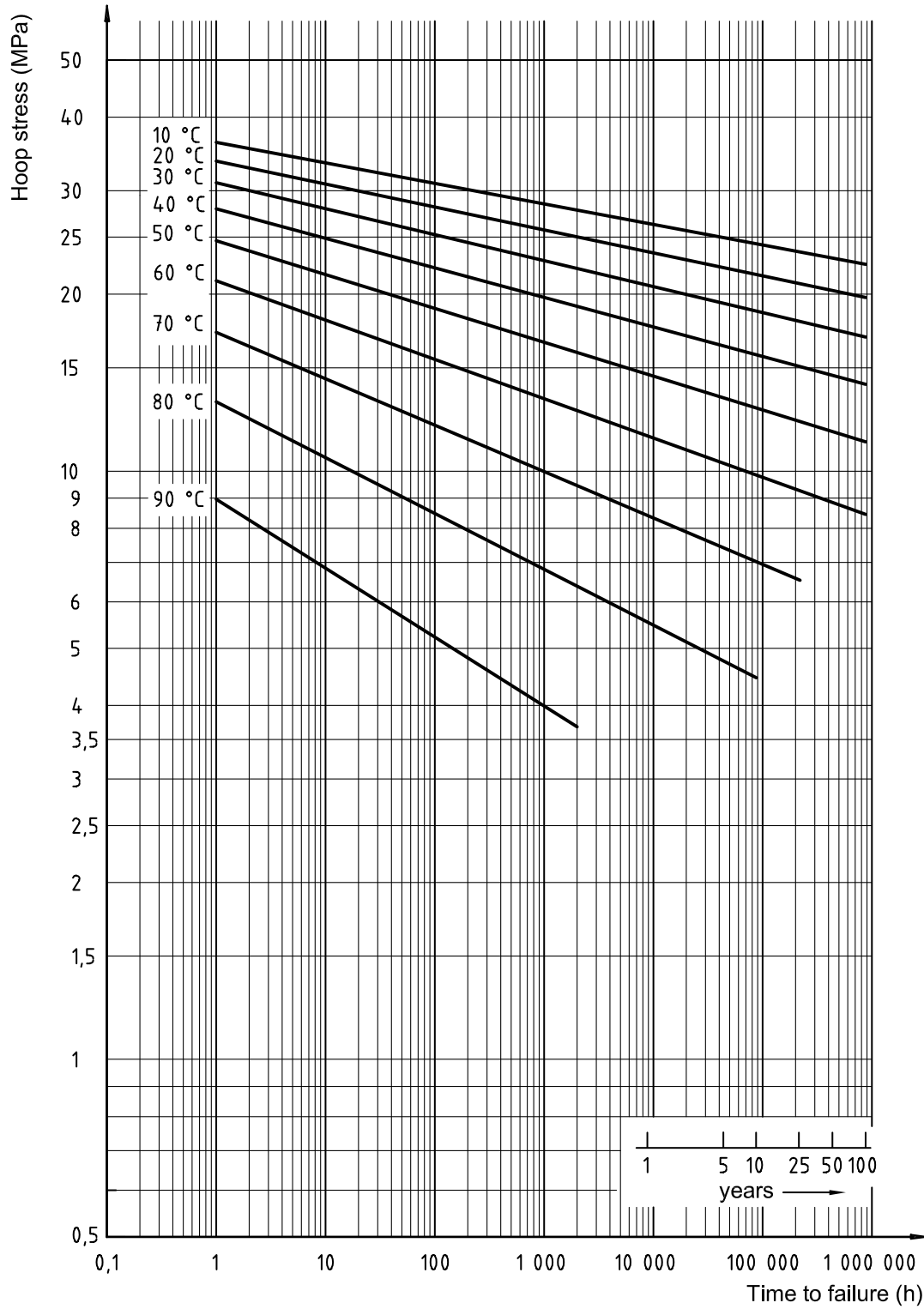

Figure C.2 — Minimum required hydrostatic strength curves for PVC-C fitting material

C.1.3 MRS-value of pipe material

When evaluated in accordance with 5.2, PVC-C pipe material shall have an MRS at least equal to 25,0 MPa.

C.1.4 MRS-value of fitting material

When evaluated in accordance with 5.2, PVC-C fitting material shall have an MRS at least equal to 20,0 MPa.

C.1.5 Other characteristics of material

C.1.5.1 Density and chlorine content

The material from which the components are manufactured shall conform to the requirements given in Table C.1.

Table C.1 — Density and chlorine content of PVC-C

Characteristic	Requirement ^a	Test temperature	Test method
Density, ρ (kg/m ³)	$1\,450 \leq \rho \leq 1\,650$	23 °C	ISO 3514
Chlorine content	≥ 55 % by mass	23 °C	ISO 1158
^a Conformity to these requirements shall be declared by the raw-material producer.			

C.1.5.2 Thermal stability

For pipes, the thermal stability of the material is regarded as proven if the pipe meets the requirements of the internal-pressure test in accordance with ISO 1167-1 at 95 °C, $\geq 8\,760$ h and 3,6 MPa (for test conditions, see Table C.9).

For fittings, the thermal stability of the material is regarded as proven if the fitting meets the requirements of the internal-pressure test in accordance with ISO 1167-1 at 90 °C, $\geq 8\,760$ h and 3,1 MPa (for test conditions, see Table C.12).

C.2 General characteristics — Colour

Components made from PVC-C should preferably be grey. Other colours shall be agreed on between manufacturer and purchaser.

C.3 Geometrical characteristics

C.3.1 Dimensions of pipes

C.3.1.1 Diameters and associated tolerances

The mean outside diameter, d_{em} , determined as the average value of measurements made at distances of d_n and $0,1d_n$ from the end of the test piece, shall be as specified in Table C.2.

C.3.1.2 Out-of-roundness

The out-of-roundness, measured at the point of manufacture, shall be as specified in Table C.2. If values for the out-of-roundness other than those given in Table C.2 are necessary, they shall be agreed on between manufacturer and purchaser.

Table C.2 — Mean outside diameters, associated tolerances and out-of-roundness of pipes

Dimensions in millimetres

Nominal outside diameter d_n	Mean outside diameter d_{em} min.	Tolerance on outside diameter ^a	Out-of-roundness ^b max.
12	12,0	+ 0,2	0,5
16	16,0	+ 0,2	0,5
20	20,0	+ 0,2	0,5
25	25,0	+ 0,2	0,5
32	32,0	+ 0,2	0,5
40	40,0	+ 0,2	0,5
50	50,0	+ 0,2	0,6
63	63,0	+ 0,3	0,8
75	75,0	+ 0,3	0,9
90	90,0	+ 0,3	1,1
110	110,0	+ 0,4	1,4
125	125,0	+ 0,4	1,5
140	140,0	+ 0,5	1,7
160	160,0	+ 0,5	2,0
180	180,0	+ 0,6	2,2
200	200,0	+ 0,6	2,4
225	225,0	+ 0,7	2,7

^a The tolerances correspond to Grade D of ISO 11922-1:1997 for $d_n \leq 50$ mm and to Grade C of ISO 11922-1:1997 for $d_n > 50$ mm.

^b The tolerances correspond to $0,5 \times$ Grade M of ISO 11922-1:1997.

C.3.1.3 Wall thicknesses and associated tolerances

The wall thickness, e , of pipes and the associated tolerance shall be as specified in Table C.3.

Table C.3 — Wall thicknesses and associated tolerances of pipes

Dimensions in millimetres

Nominal outside diameter d_n	Wall thickness, e , and associated tolerance ^a							
	Pipe series S and standard dimension ratio SDR							
	S 10 SDR 21		S 6,3 SDR 13,6		S 5 SDR 11		S 4 SDR 9	
	e min.	b	e min.	b	e min.	b	e min.	b
12	—	—	1,4	+ 0,4	1,4	+ 0,4	1,4	+ 0,4
16	—	—	1,4	+ 0,4	1,5	+ 0,4	1,8	+ 0,4
20	—	—	1,5	+ 0,4	1,9	+ 0,4	2,3	+ 0,5
25	—	—	1,9	+ 0,4	2,3	+ 0,5	2,8	+ 0,5
32	1,6	+ 0,4	2,4	+ 0,5	2,9	+ 0,5	3,6	+ 0,6
40	1,9	+ 0,4	3,0	+ 0,5	3,7	+ 0,6	4,5	+ 0,7
50	2,4	+ 0,5	3,7	+ 0,6	4,6	+ 0,7	5,6	+ 0,8
63	3,0	+ 0,5	4,7	+ 0,7	5,8	+ 0,8	7,1	+ 1,0
75	3,6	+ 0,6	5,6	+ 0,8	6,8	+ 0,9	8,4	+ 1,1
90	4,3	+ 0,7	6,7	+ 0,9	8,2	+ 1,1	10,1	+ 1,3
110	5,3	+ 0,8	8,1	+ 1,1	10,0	+ 1,2	12,3	+ 1,5
125	6,0	+ 0,8	9,2	+ 1,2	11,4	+ 1,4	14,0	+ 1,6
140	6,7	+ 0,9	10,3	+ 1,3	12,7	+ 1,5	15,7	+ 1,8
160	7,7	+ 1,0	11,8	+ 1,4	14,6	+ 1,7	17,9	+ 2,0
180	8,6	+ 1,1	13,3	+ 1,6	—	—	—	—
200	9,6	+ 1,2	14,7	+ 1,7	—	—	—	—
225	10,8	+ 1,3	16,6	+ 1,9	—	—	—	—

NOTE For safety reasons, the minimum wall thickness should not be less than 1,4 mm.

^a All dimensions correspond to those given in ISO 4065.

^b The tolerances have been calculated from the expression $(0,1e + 0,2)$ mm and rounded up to the nearest 0,1 mm.

C.3.2 Dimensions of sockets for solvent cementing

The dimensions of cylindrical sockets for solvent cementing (see Figure C.3) shall be as specified in Table C.4.

A1 Text deleted A1

C.3.3 Dimensions of fittings

C.3.3.1 General

This annex is applicable to the following types of fittings:

- fittings for solvent cementing;
- flange adaptors and loose backing flanges;
- mechanical fittings.

C.3.3.2 Fittings for solvent cementing

C.3.3.2.1 Nominal diameter(s)

The nominal diameter(s), d_n , of a fitting for solvent cementing shall correspond to, and be designated by, the nominal outside diameter(s) of the pipe(s) for which the fitting is designed.

C.3.3.2.2 Diameters and lengths of cylindrical sockets

The diameters and lengths of cylindrical sockets for solvent cementing (see Figure C.3) shall be as specified in Table C.4.

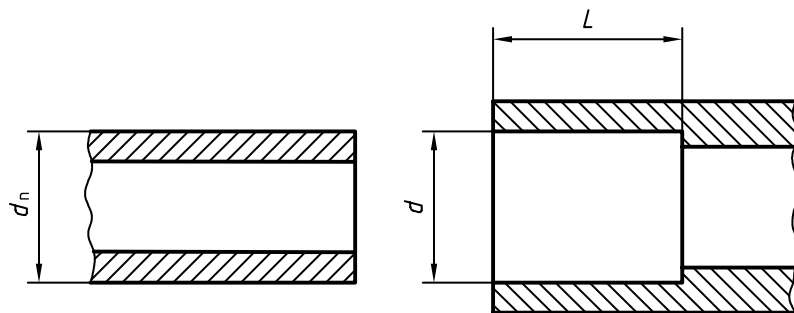

Key

- d_n nominal outside diameter
- d_i inside diameter of socket at midpoint of socket length
- L length of socket, i.e. distance from socket mouth to shoulder, if any

Figure C.3 — Diameters and lengths of cylindrical sockets for solvent cementing

Table C.4 — Diameters and lengths of cylindrical sockets for solvent cementing

Dimensions in millimetres

Nominal outside diameter of pipe d_n	Mean inside diameter of socket d_{im}		Out-of-roundness ^a max.	Socket length ^b L min.
	min.	max.		
12	12,1	12,3	0,25	11,0
16	16,1	16,3	0,25	13,0
20	20,1	20,3	0,25	15,0
25	25,1	25,3	0,25	17,5
32	32,1	32,3	0,25	21,0
40	40,1	40,3	0,25	25,0
50	50,1	50,3	0,3	30,0
63	63,1	63,3	0,4	36,5
75	75,1	75,3	0,5	42,5
90	90,1	90,3	0,6	50,0
110	110,1	110,4	0,7	60,0
125	125,1	125,4	0,8	67,5
140	140,2	140,5	0,9	75,0
160	160,2	160,5	1,0	85,0
180	180,2	180,6	1,1	95,0
200	200,2	200,6	1,2	105,0
225	225,3	225,7	1,4	117,5

^a The tolerances for the out-of-roundness are rounded values obtained from those in ISO 11922-1:1997, grade M, by multiplying by 0,25 (see ISO 727-1).

^b The minimum socket length is equal to $(0,5d_n + 5)$ mm (see ISO 727-1).

C.3.3.2.3 Socket taper of cylindrical sockets

The maximum included angle of the socket portion of a fitting shall not exceed 0° 40' for $d_n \leq 63$ mm and 0° 30' for $d_n \geq 75$ mm.

 Text deleted 

C.3.3.2.5 Other dimensions

Other dimensions of sockets for solvent cementing shall be as specified by the manufacturer.

C.3.3.3 Flange adaptors and loose backing flanges

C.3.3.3.1 Dimensions of flange adaptors for solvent cementing

The dimensions of flange adaptors for solvent cementing (see Figure C.5) shall be as specified in Table C.6.

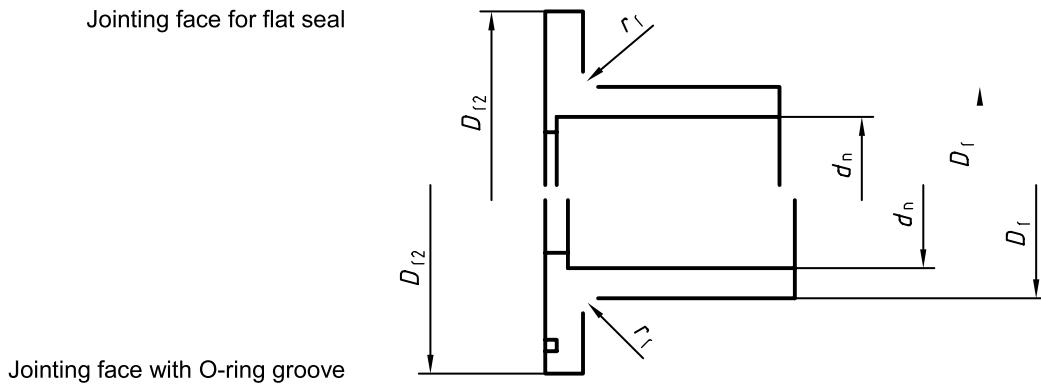

Figure C.5 — Dimensions of flange adaptors for solvent cementing

Table C.6 — Dimensions of flange adaptors for solvent cementing

Dimensions in millimetres

Nominal outside diameter of corresponding pipe d_n	Outside diameter of chamfer on shoulder D_{r1}	Outside diameter of flange adaptor D_{r2}	Radius of chamfer on shoulder r_f
16	22	29	1
20	27	34	1
25	33	41	1,5
32	41	50	1,5
40	50	61	2
50	61	73	2
63	76	90	2,5
75	90	106	2,5
90	108	125	3
110	131	150	3
125	148	170	3
140	165	188	4
160	188	213	4
180	201	247	4
200	224	250	4
225	248	274	4

C.3.3.3.2 Dimensions of loose backing flanges for use with flange adaptors for solvent cementing

The dimensions of loose backing flanges for use with flange adaptors for solvent cementing (see Figure C.6) shall be as specified in Table C.7.

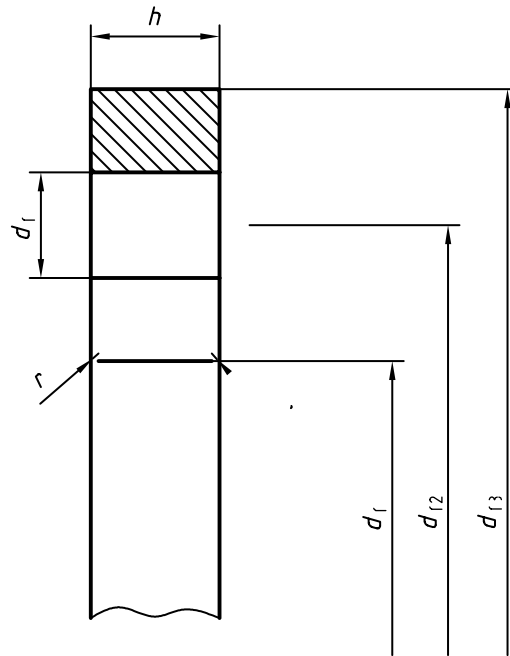

NOTE The thickness, h , of the loose backing flange is dependent on the material used.

Figure C.6 — Dimensions of loose backing flanges for use with flange adaptors for solvent cementing

Table C.7 — Dimensions of loose backing flanges for use with flange adaptors for solvent cementing

Dimensions in millimetres

Nominal outside diameter of corresponding pipe d_n	Nominal size of flange DN	Inside diameter of flange d_{f1}	Pitch circle diameter of bolt holes d_{f2}	Outside diameter of flange d_{f3} min.	Diameter of bolt holes d_{f4}	Radius of flange r	Number of bolt holes	Metric thread of bolt
16	10	23	60	90	14	1	4	M12
20	15	28	65	95	14	1	4	M12
25	20	34	75	105	14	1,5	4	M12
32	25	42	85	115	14	1,5	4	M12
40	32	51	100	140	18	2	4	M16
50	40	62	110	150	18	2	4	M16
63	50	78	125	165	18	2,5	4	M16
75	65	92	145	185	18	2,5	4	M16
90	80	110	160	200	18	3	8	M16
110	100	133	180	220	18	3	8	M16
125	125	150	210	250	18	3	8	M16
140	125	167	210	250	18	4	8	M16
160	150	190	240	285	22	4	8	M20
180	175	203	240	315	22	4	8	M20
200	200	226	295	340	22	4	8	M20
225	200	250	295	340	22	4	8	M20

C.4 Mechanical characteristics

C.4.1 Mechanical characteristics of pipes

C.4.1.1 Resistance to internal pressure

When tested as specified in Table C.8 under the test conditions indicated, using the test set-up indicated in Table C.9, pipes shall withstand the hydrostatic stress without bursting or leakage.

NOTE The internal pressure to be used is calculated as indicated in 8.2.

Table C.8 — Requirements for internal-pressure testing of pipes

Characteristic	Requirement	Test conditions			Test method
		Hydrostatic (hoop) stress MPa	Time h	Number of test pieces	
Resistance to internal pressure at 20 °C	No failure during test period	43,0	≥1	3	ISO 1167-1
Resistance to internal pressure at 95 °C		5,6	≥165	3	ISO 1167-1
Resistance to internal pressure at 95 °C		4,6	≥1 000	3	ISO 1167-1

Table C.9 — Test set-up for internal-pressure testing of pipes

End caps	Type A as specified in ISO 1167:1996
Orientation	Not specified
Conditioning period	≥ 1 h
Type of test	Water-in-water or water-in-air ^{a, b}
<p>^a When testing at 95 °C (see Table C.8), only water-in-air shall be used.</p> <p>^b When testing at 20 °C, either water-in-water or water-in-air may be used except in cases of dispute when water-in-water shall be used.</p>	

C.4.1.2 Resistance to impact

When tested in accordance with ISO 3127 for resistance to external blows at 0 °C, pipes shall have a true impact rate (TIR) of not more than 10 % when using the falling weights and fall heights given in Table C.10.

NOTE For practical reasons, this test is not relevant to pipes with $d_n < 20$ mm.

Table C.10 — Requirements for impact testing of pipes

Nominal outside diameter d_n mm	Mass of falling weight kg	Fall height of falling weight m
20	0,5	0,4
25	0,5	0,5
32	0,5	0,6
40	0,5	0,8
50	0,5	1,0
63	0,8	1,0
75	0,8	1,0
90	0,8	1,2
110	1,0	1,6
125	1,25	2,0
140	1,6	1,8
160	1,6	2,0
180	2,0	1,8
200	2,0	2,0
225	2,5	1,8

C.4.2 Mechanical characteristics of fittings

When tested as specified in Table C.11 under the test conditions indicated, using the test set-up indicated in Table C.12, fittings shall withstand the hydrostatic stress without bursting or leakage.

NOTE The internal pressure to be used is calculated as indicated in 8.2.

The fitting shall be connected to the corresponding pipe in accordance with 12.2, using the relevant jointing method (solvent cement or mechanical jointing) in such a way that the required hydrostatic stress given in Table C.11 can be applied. The free length, l_0 , of the pipe section shall be as specified in Table C.12.

Store fittings connected to pipe sections by solvent cementing for at least 20 days at ambient temperature and after that 4 days at 80 °C to allow the cement to set, unless the adhesive manufacturer prescribes other setting times.

Table C.11 — Requirements for internal-pressure testing of fittings

Characteristic	Requirement	Test conditions			Test method ^a
		Hydrostatic (hoop) stress MPa	Time h	Number of test pieces	
Resistance to internal pressure at 20 °C	No failure during test period	33,6	≥1	3	ISO 1167-1
Resistance to internal pressure at 60 °C		21,1	≥1	3	ISO 1167-1
Resistance to internal pressure at 80 °C		6,9	≥1 000	3	ISO 1167-1

^a Fittings shall be prepared and tested in accordance with ISO 1167-1.

A1

Table C.12 — Test set-up for internal-pressure testing of fittings

End caps	Type A as specified in ISO 1167:1996
Free length, l_0	≥ 3 d_n ^a
Orientation	Not specified
Conditioning period	≥ 1 h
Type of test	Water-in-water or water-in-air ^{b, c}

^a For fittings with a change in direction (e.g. tees, bends), the free length, l_0 , between the socket mouth of a solvent-cemented pipe and the end cap shall not exceed d_n .

^b When testing at 60 °C (see Table C.11), only water-in-air shall be used.

^c When testing at 20 °C or 80 °C, either water-in-water or water-in-air may be used except in cases of dispute when water-in-air shall be used.

C.4.3 Mechanical characteristics of valves

Valves shall conform to the requirements of ISO 16135, ISO 16136, ISO 16137, ISO 16138, ISO 16139 or ISO 21787, as applicable, depending on the valve type.

C.5 Physical characteristics

C.5.1 Physical characteristics of pipes

When determined in accordance with the test methods specified in Table C.13, using the parameters indicated, the physical characteristics of pipes shall conform to the requirements given in Table C.13.

Table C.13 — Physical characteristics of pipes

Characteristic	Requirement	Test parameters		Test method
Vicat softening temperature $\overline{A_1}$ ^a $\overline{A_1}$	VST \geq 110 °C	As specified in ISO 2507-2		ISO 2507-1
Longitudinal reversion	\leq 5 % The pipe shall exhibit no bubbles or cracks	Temperature Immersion time: $e \leq$ 4 mm $4 \text{ mm} < e \leq$ 16 mm $e >$ 16 mm Length of test piece	150 °C 30 min 60 min 120 min 200 mm	ISO 2505-1:1994 together with ISO 2505-2:1994 Method B: Air

$\overline{A_1}$ ^a Test samples may be annealed prior to testing at conditions recommended by the manufacturer. $\overline{A_1}$

C.5.2 Physical characteristics of fittings

C.5.2.1 General

When tested in accordance with the test methods specified in Table C.14, using the parameters indicated, the physical characteristics of fittings shall conform to the requirements given in Table C.14.

Table C.14 — Physical characteristics of fittings

Characteristic	Requirement	Test parameters		Test method
Vicat softening temperature $\overline{A_1}$ ^a $\overline{A_1}$	VST \geq 103 °C	As specified in ISO 2507-2		ISO 2507-1
Effects of heating	The fittings shall not exhibit any blisters or signs of weld-line splitting ^a No surface damage in the area of any injection point shall penetrate by more than 30 % of the wall thickness at that point. Outside the area of any injection point, no surface damage shall occur ^b	Temperature Immersion time: $e \leq$ 3 mm $3 \text{ mm} < e \leq$ 10 mm $e >$ 10 mm Examination of test pieces after heating	150 °C 15 min 30 min 60 min See C.5.2.2	ISO 580:— Air-oven method

^a The weld-line is likely to become more pronounced, but this shall not be taken as a sign of weld-line opening.

^b For sprue-gating, the area of the injection point shall be calculated using a radius, R , of $0,3d_n$, with a maximum value of 50 mm. For fittings moulded by end-gating techniques, e.g. ring or diaphragm methods, the gating area shall be a cylindrical portion with a length, L_1 , of $0,3d_n$, with a maximum value of 50 mm (see Figure C.7). Any cracks or delamination in the wall of the fitting adjacent to the injection area, parallel to the axis of the fitting, shall not penetrate in the axial direction by more than 20 % of the length L_1 given above.

$\overline{A_1}$ ^a Test samples may be annealed prior to testing at conditions recommended by the manufacturer. $\overline{A_1}$

C.5.2.2 Effects of heating — Examination of test pieces

After removal from the air oven, the test pieces shall be cut, using a razor-sharp blade, from the mouth of the socket or spigot end of the fitting over its full length and the exposed surfaces examined.

The number of cuts made on each test piece shall be as follows:

- For fittings of $d_n \leq 160$ mm:
 not less than two cuts equally spaced around the periphery of the mouth of each socket or spigot end of the fitting.
- For fittings of $d_n > 160$ mm:
 not less than four cuts equally spaced around the periphery of the mouth of each socket or spigot end of the fitting.

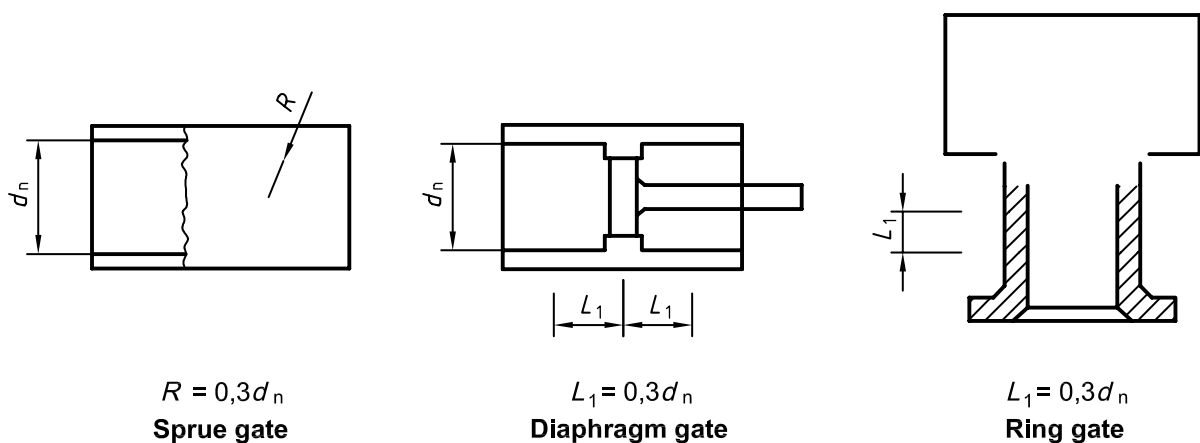

Figure C.7 — Injection gating areas

C.5.3 Physical characteristics of valves

In addition to the requirements of ISO 16135, ISO 16136, ISO 16137, ISO 16138, ISO 16139 or ISO 21787, as applicable, depending on the valve type, the physical characteristics of valves shall conform to the requirements of C.5.2.

C.6 Fitness for purpose of the system

The fitness for purpose of the system shall be deemed to apply when test assemblies, assembled in accordance with 12.2 and tested using the test methods and indicated parameters as specified in Table C.15, conform to the requirements given in Table C.15.

Table C.15 — General requirements for fitness for purpose of the system

Characteristic	Requirement	Test parameters		Test method ^a
Hydrostatic strength at 20 °C	No failure during test period	End caps Orientation Test temperature Type of test Hydrostatic (hoop) stress Conditioning period Test period	Type A as specified in ISO 1167:1996 Not specified 20 °C Water-in-water or water-in-air ^b 17,0 MPa ≥ 1 h ≥ 1 000 h	ISO 1167 and ISO 12092
Hydrostatic strength at 80 °C	No failure during test period	End caps Orientation Test temperature Type of test Hydrostatic (hoop) stress Conditioning period Test period	Type A as specified in ISO 1167:1996 Not specified 80 °C Water-in-water or water-in-air ^b 4,8 MPa ≥ 1 h ≥ 1 000 h	ISO 1167 and ISO 12092
^a Assemblies of pipes and fittings shall be prepared in accordance with ISO 12092 and tested in accordance with ISO 1167. ^b In cases of dispute, water-in-air shall be used.				

Bibliography

- [1] ISO 3, *Preferred numbers — Series of preferred numbers*
- [2] ISO 497, *Guide to the choice of series of preferred numbers and of series containing more rounded values of preferred numbers*
- [3] ISO 4422 (all parts), *Pipes and fittings made of unplasticized poly(vinyl chloride) (PVC-U) for water supply — Specifications*
- [4] ISO 4433 (all parts), *Thermoplastics pipes — Resistance to liquid chemicals — Classification*
- [5] ISO 9001, *Quality management systems — Requirements*
- [6] ISO 9393 (all parts), *Thermoplastics valves — Pressure test methods and requirements*
- [7] ISO 10241, *International terminology standards — Preparation and layout*
- [8] ISO 10931 (all parts), *Plastics piping systems for industrial applications — Poly(vinylidene fluoride) (PVDF)*
- [9] ISO 15494, *Plastics piping systems for industrial applications — Polybutene (PB), polyethylene (PE) and polypropylene (PP) — Specifications for components and the system — Metric series*
- [10] ISO/TR 16913, *Plastics pipes and fittings — Definitions of types of test*

Correspondence between International and European Standards

Due to the intention to publish this International Standard as a European Standard, the following list is given of European Standards which correspond to the International Standards for the test methods used in this International Standard. Although it has no corresponding International Standard, EN 1778 is included for the sake of completeness. Attention is drawn to the fact that, for a particular test method, the technical content of the International Standard and the European Standard may be different. The listing is therefore given for information only and is not intended to indicate technical conformity between the documents.

- | | |
|------------------------------------|---|
| ISO 580:1990 | EN 763, <i>Plastics piping and ducting systems — Injection-moulded thermoplastics fittings — Test method for visually assessing effects of heating</i> |
| ISO 1167:1996 | EN 921, <i>Plastics piping systems — Thermoplastics pipes — Determination of resistance to internal pressure at constant temperature</i> |
| ISO 2505-1:1994
ISO 2505-2:1994 | EN 743, <i>Plastics piping and ducting systems — Thermoplastics pipes — Determination of the longitudinal reversion</i> |
| ISO 2507-1:1995
ISO 2507-2:1995 | EN 727, <i>Plastics piping and ducting systems — Thermoplastics pipes and fittings — Determination of Vicat softening temperature (VST)</i> |
| ISO 3127:1994 | EN 744, <i>Plastics piping and ducting systems — Thermoplastics pipes — Test method for resistance to external blows by the round-the-clock method</i> |
| ISO 9852:1995 | EN 580, <i>Plastics piping systems — Unplasticized poly(vinyl chloride) (PVC-U) pipes — Test method for the resistance to dichloromethane at a specified temperature (DCMT)</i> |

BS EN ISO 15493:2003+A1:2017
ISO 15493:2003+A1:2016

- ISO 9853:1991 EN 802, *Plastics piping and ducting systems — Injection-moulded thermoplastics fittings for pressure piping systems — Test method for maximum deformation by crushing*
- ISO 12092:2000 EN 12107, *Plastics piping systems — Injection-moulded thermoplastics fittings, valves and ancillary equipment — Determination of the long-term hydrostatic strength of thermoplastics materials for injection moulding of piping components*
- EN 1778, *Characteristic values for welded thermoplastic constructions — Determination of allowable stresses and moduli for design of thermoplastics equipment*

Annex ZA
(normative)

**Normative references to international publications
with their relevant European publications**

This European Standard incorporates by dated or undated reference, provisions from other publications. These normative references are cited at the appropriate places in the text and the publications are listed hereafter. For dated references, subsequent amendments to or revisions of any of these publications apply to this European Standard only when incorporated in it by amendment or revision. For undated references the latest edition of the publication referred to applies (including amendments).

NOTE Where an International Publication has been modified by common modifications, indicated by (mod.), the relevant EN/HD applies.

Publication	Year	Title	EN/HD	Year
ISO 228-1	2000	Pipe threads where pressure-tight joints are not made on the threads - Part 1: Dimensions, tolerances and designation	EN ISO 228-1	2003
ISO 306	1994	Plastics - Thermoplastic materials - Determination of Vicat softening temperature (VST)	EN ISO 306	1996
ISO 472	1999	Plastics - Vocabulary	EN ISO 472	2001
ISO 1043-1	2001	Plastics - Symbols and abbreviated terms - Part 1: Basic polymers and their special characteristics	EN ISO 1043-1	2001
ISO 1158	1998	Plastics - Vinyl chloride homopolymers and copolymers - Determination of chlorine content	EN ISO 1158	1998
ISO 9080	2003	Plastics piping and ducting systems - Determination of the long-term hydrostatic strength of thermoplastics materials in pipe form by extrapolation	EN ISO 9080	2003
ISO 12162	1995	Thermoplastics materials for pipes and fittings for pressure applications - Classification and designation - Overall service (design) coefficient	EN ISO 12162	1995

Annex ZB
 (informative)

Clauses of this Standard addressing essential requirements or other provisions of EU Directives

This Standard has been prepared under a mandate given to CEN by the European Commission and the European Free Trade Association. The following clauses of this standard mentioned in this annex meet the requirements of the mandate given by EU Directive for Pressure Equipment 97/23/EC (PED).

WARNING: Other requirements and other EU Directives may be applicable to the products falling within the scope of this standard.

Table ZA.1 - Clauses of this Standard addressing essential requirements of EU Directive 97/23/EC (PED)

Clause	Requirement	Clause of Annex I of the PED
Annexes A, B and C	Design for adequate strength	2.2.1
12	Permanent jointing	3.1.2
17	Traceability	3.1.5
8 and 12	Hydrostatic test pressure	3.2.2 and 7.4
5, 6 and 7	Materials	4.1, 4.2 a)
14 and 15	Design of piping system	6
Annexes A, B and C	Allowable stresses	7

Compliance with these clauses of this standard provides one means of conforming with the specific essential requirements of the EU Directive concerned and associated EFTA regulations.

NOTE Requirements of those clauses of Annex I of the PED that are not listed in Table ZA. 1

- are not applicable to components in accordance with this standard;
- could be applicable to the pressure equipment and have to be respected by the industrial plant manufacturer and/or by the user of the components.

British Standards Institution (BSI)

BSI is the national body responsible for preparing British Standards and other standards-related publications, information and services.

BSI is incorporated by Royal Charter. British Standards and other standardization products are published by BSI Standards Limited.

About us

We bring together business, industry, government, consumers, innovators and others to shape their combined experience and expertise into standards-based solutions.

The knowledge embodied in our standards has been carefully assembled in a dependable format and refined through our open consultation process. Organizations of all sizes and across all sectors choose standards to help them achieve their goals.

Information on standards

We can provide you with the knowledge that your organization needs to succeed. Find out more about British Standards by visiting our website at bsigroup.com/standards or contacting our Customer Services team or Knowledge Centre.

Buying standards

You can buy and download PDF versions of BSI publications, including British and adopted European and international standards, through our website at bsigroup.com/shop, where hard copies can also be purchased.

If you need international and foreign standards from other Standards Development Organizations, hard copies can be ordered from our Customer Services team.

Copyright in BSI publications

All the content in BSI publications, including British Standards, is the property of and copyrighted by BSI or some person or entity that owns copyright in the information used (such as the international standardization bodies) and has formally licensed such information to BSI for commercial publication and use.

Save for the provisions below, you may not transfer, share or disseminate any portion of the standard to any other person. You may not adapt, distribute, commercially exploit, or publicly display the standard or any portion thereof in any manner whatsoever without BSI's prior written consent.

Storing and using standards

Standards purchased in soft copy format:

- A British Standard purchased in soft copy format is licensed to a sole named user for personal or internal company use only.
- The standard may be stored on more than 1 device provided that it is accessible by the sole named user only and that only 1 copy is accessed at any one time.
- A single paper copy may be printed for personal or internal company use only.

Standards purchased in hard copy format:

- A British Standard purchased in hard copy format is for personal or internal company use only.
- It may not be further reproduced – in any format – to create an additional copy. This includes scanning of the document.

If you need more than 1 copy of the document, or if you wish to share the document on an internal network, you can save money by choosing a subscription product (see 'Subscriptions').

Reproducing extracts

For permission to reproduce content from BSI publications contact the BSI Copyright & Licensing team.

Subscriptions

Our range of subscription services are designed to make using standards easier for you. For further information on our subscription products go to bsigroup.com/subscriptions.

With **British Standards Online (BSOL)** you'll have instant access to over 55,000 British and adopted European and international standards from your desktop. It's available 24/7 and is refreshed daily so you'll always be up to date.

You can keep in touch with standards developments and receive substantial discounts on the purchase price of standards, both in single copy and subscription format, by becoming a **BSI Subscribing Member**.

PLUS is an updating service exclusive to BSI Subscribing Members. You will automatically receive the latest hard copy of your standards when they're revised or replaced.

To find out more about becoming a BSI Subscribing Member and the benefits of membership, please visit bsigroup.com/shop.

With a **Multi-User Network Licence (MUNL)** you are able to host standards publications on your intranet. Licences can cover as few or as many users as you wish. With updates supplied as soon as they're available, you can be sure your documentation is current. For further information, email subscriptions@bsigroup.com.

Revisions

Our British Standards and other publications are updated by amendment or revision.

We continually improve the quality of our products and services to benefit your business. If you find an inaccuracy or ambiguity within a British Standard or other BSI publication please inform the Knowledge Centre.

Useful Contacts

Customer Services

Tel: +44 345 086 9001

Email (orders): orders@bsigroup.com

Email (enquiries): cservices@bsigroup.com

Subscriptions

Tel: +44 345 086 9001

Email: subscriptions@bsigroup.com

Knowledge Centre

Tel: +44 20 8996 7004

Email: knowledgecentre@bsigroup.com

Copyright & Licensing

Tel: +44 20 8996 7070

Email: copyright@bsigroup.com

BSI Group Headquarters

389 Chiswick High Road London W4 4AL UK