

Fasteners — Preloading test for the detection of hydrogen embrittlement — Parallel bearing surface method

The European Standard EN ISO 15330:1999 has the status of a
British Standard

ICS 21.060.01

National foreword

This British Standard is the English language version of EN ISO 15330:1999. It is identical with ISO 15330:1999.

The UK participation in its preparation was entrusted by Technical Committee FME/9, Bolts, nuts and accessories, to Subcommittee FME/9/1, Mechanical properties of fasteners, which has the responsibility to:

- aid enquirers to understand the text;
- present to the responsible international/European committee any enquiries on the interpretation, or proposals for change, and keep the UK interests informed;
- monitor related international and European developments and promulgate them in the UK.

A list of organizations represented on this subcommittee can be obtained on request to its secretary.

Cross-references

Attention is drawn to the fact that CEN and CENELEC Standards normally include an annex which lists normative references to international publications with their corresponding European publications. The British Standards which implement international or European publications referred to in this document may be found in the BSI Standards Catalogue under the section entitled "International Standards Correspondence Index", or by using the "Find" facility of the BSI Standards Electronic Catalogue.

A British Standard does not purport to include all the necessary provisions of a contract. Users of British Standards are responsible for their correct application.

Compliance with a British Standard does not of itself confer immunity from legal obligations.

Summary of pages

This document comprises a front cover, an inside front cover, pages i and ii, the EN ISO title page, page 2, the ISO title page, pages ii to iv, pages 1 to 8 and a back cover.

This standard has been updated (see copyright date) and may have had amendments incorporated. This will be indicated in the amendment table on the inside front cover.

Amendments issued since publication

Amd. No.	Date	Comments

This British Standard, having been prepared under the direction of the Engineering Sector Committee, was published under the authority of the Standards Committee and comes into effect on 15 November 1999

© BSI 04-2000

ISBN 0 580 35013 4

Contents

	Page
National foreword	Inside front cover
Foreword	2
Foreword	iii
Text of ISO 15330	1

English version

Fasteners — Preloading test for the detection of hydrogen embrittlement — Parallel bearing surface method

(ISO 15330:1999)

Eléments de fixation — Essai de précharge pour la détection de la fragilisation par l'hydrogène — Méthode des plaques parallèles (ISO 15330:1999)

Verbindungselemente — Verspannungsversuch zur Entdeckung von Wasserstoffversprödung — Verfahren mit parallelen Auflageflächen (ISO 15330:1999)

This European Standard was approved by CEN on 21 July 1999.

CEN members are bound to comply with the CEN/CENELEC Internal Regulations which stipulate the conditions for giving this European Standard the status of a national standard without any alteration. Up-to-date lists and bibliographical references concerning such national standards may be obtained on application to the Central Secretariat or to any CEN member.

This European Standard exists in three official versions (English, French, German). A version in any other language made by translation under the responsibility of a CEN member into its own language and notified to the Central Secretariat has the same status as the official versions.

CEN members are the national standards bodies of Austria, Belgium, Czech Republic, Denmark, Finland, France, Germany, Greece, Iceland, Ireland, Italy, Luxembourg, Netherlands, Norway, Portugal, Spain, Sweden, Switzerland and United Kingdom.

CEN

European Committee for Standardization
Comité Européen de Normalisation
Europäisches Komitee für Normung

Central Secretariat: rue de Stassart 36, B-1050 Brussels

Foreword

The text of the International Standard ISO 15330:1999 has been prepared by Technical Committee ISO/TC 2 “Fasteners” in collaboration with Technical Committee CEN/TC 185 “Threaded and non-threaded mechanical fasteners and accessories”, the secretariat of which is held by DIN.

This European Standard shall be given the status of a national standard, either by publication of an identical text or by endorsement, at the latest by March 2000, and conflicting national standards shall be withdrawn at the latest by March 2000.

According to the CEN/CENELEC Internal Regulations, the national standards organizations of the following countries are bound to implement this European Standard: Austria, Belgium, Czech Republic, Denmark, Finland, France, Germany, Greece, Iceland, Ireland, Italy, Luxembourg, Netherlands, Norway, Portugal, Spain, Sweden, Switzerland and the United Kingdom.

Endorsement notice

The text of the International Standard ISO 15330:1999 was approved by CEN as a European Standard without any modification.

NOTE Normative references to International Standards are listed in Annex ZA (normative).

INTERNATIONAL
STANDARD

ISO
15330

First edition
1999-09-01

**Fasteners — Preloading test for the
detection of hydrogen embrittlement —
Parallel bearing surface method**

*Éléments de fixation — Essai de précharge pour la détection de la
fragilisation par l'hydrogène — Méthode des plaques parallèles*



Reference number
ISO 15330:1999(E)

Contents

	Page
Foreword	iii
Introduction	1
1 Scope	1
2 Normative references	1
3 Terms and definitions	1
4 Principle	2
5 Test apparatus	2
6 Sampling	4
7 Test procedure	5
8 Test evaluation	6
9 Test report	6
Bibliography	7
Annex ZA (normative) Normative references to international publications with their relevant European publications	8
Figure 1 — Test devices for metric bolts, screws and stud	2
Figure 2 — Example for a test device for bolts and screws with no flat bearing surface	3
Figure 3 — Test apparatus for thread rolling screws, self-tapping screws or self-drilling screws	4
Figure 4 — Test apparatus for conical spring washers	4

Foreword

ISO (the International Organization for Standardization) is a worldwide federation of national standards bodies (ISO member bodies). The work of preparing International Standards is normally carried out through ISO technical committees. Each member body interested in a subject for which a technical committee has been established has the right to be represented on that committee. International organizations, governmental and non-governmental, in liaison with ISO, also take part in the work. ISO collaborates closely with the International Electrotechnical Commission (IEC) on all matters of electrotechnical standardization.

International Standards are drafted in accordance with the rules given in the ISO/IEC Directives, Part 3.

Draft International Standards adopted by the technical committees are circulated to the member bodies for voting. Publication as an International Standard requires approval by at least 75 % of the member bodies casting a vote.

International Standard ISO 15330 was prepared by Technical Committee ISO/TC 2, *Fasteners*, Subcommittee SC 1, *Mechanical properties of fasteners*.

Introduction

When atomic hydrogen enters steels, it can cause loss of ductility or load-carrying ability, cracking (usually as submicroscopic cracks) or catastrophic brittle failures at applied stresses well below the yield strength or even the normal design strength for the alloys. This phenomenon often occurs in alloys that show no significant loss in ductility when measured by conventional tensile tests, and is frequently referred to as hydrogen-induced delayed brittle failure, hydrogen stress cracking or hydrogen embrittlement. The hydrogen can be introduced during heat treatment, gas carburizing, cleaning, pickling, phosphating, electroplating and in the service environment as a result of cathodic protection or corrosion reactions. Hydrogen can also be introduced during fabrication, for example during roll forming, machining, and drilling due to coolant or lubricant break-down as well as during welding or brazing operations.

1 Scope

This International Standard specifies a preloading test which is able to detect the occurrence of hydrogen embrittlement of fasteners at room temperature.

This test is applicable to

- metric bolts, screws and studs;
- thread rolling screws;
- self-tapping screws;
- self-drilling screws;
- nuts;
- washers

which are made of steel and are under tensile stress.

The test shall be carried out within a temperature range of 10 °C to 35 °C.

The test is suitable only for in-process control and may be carried out after any step of the manufacturing process. It is not intended as an acceptance test. It is capable of assessing differences or changes in processing conditions or techniques and to determine the effectiveness of the various processing steps including pre- and post-coating treatments (baking) to reduce the mobile hydrogen in the fasteners.

This test does not relieve the manufacturer or processor from the responsibility of imposing and monitoring suitable process control.

NOTE The chance of detecting hydrogen embrittlement decreases significantly if the test is started more than 24 h after the last step of manufacturing process. Therefore, in normal cases this test is not suitable for acceptance testing.

Special attention shall be given to the reference test in clause 7.3.

2 Normative references

The following normative documents contain provisions which, through reference in this text, constitute provisions of this International Standard. For dated references, subsequent amendments to, or revisions of, any of these publications do not apply. However, parties to agreements based on this International Standard are encouraged to investigate the possibility of applying the most recent editions of the normative documents indicated below. For undated references, the latest edition of the normative document referred to applies. Members of ISO and IEC maintain registers of currently valid International Standards. ISO 273:1979, *Fasteners — Clearance holes for bolts and screws*.

ISO 2702:1992, *Heat-treated steel tapping screws — Mechanical properties*.

ISO 7085:1999, *Mechanical and performance requirements of case hardened and tempered metric thread rolling screws*.

ISO 10666:1999, *Drilling screws with tapping screw thread — Mechanical and functional properties*.

3 Terms and definitions

For the purposes of this International Standard the following terms and definitions apply.

3.1

susceptibility to hydrogen embrittlement

characteristic of a steel fastener to display brittle failure due to the presence of mobile hydrogen and when subjected to a significant degree of tensile stress and/or adverse service conditions

NOTE 1 With increasing susceptibility to hydrogen embrittlement, the critical amount of mobile hydrogen which may cause brittle failure decreases markedly.

NOTE 2 After the manufacturing process, susceptibility to hydrogen embrittlement cannot be reduced or changed into an unsusceptible condition, even by any post-coating heat treatment (baking).

3.2

risk of hydrogen embrittlement

risk of failure which arises if fasteners made from steel which are susceptible to hydrogen embrittlement absorb hydrogen and are subjected to tensile stress and/or residual tensile stress

NOTE The risk of hydrogen embrittlement can be reduced when in the relevant process steps hydrogen supply is minimized and/or when suitable post-coating heat treatment is carried out to enable hydrogen to effuse and/or to trap hydrogen irreversibly in the steel.

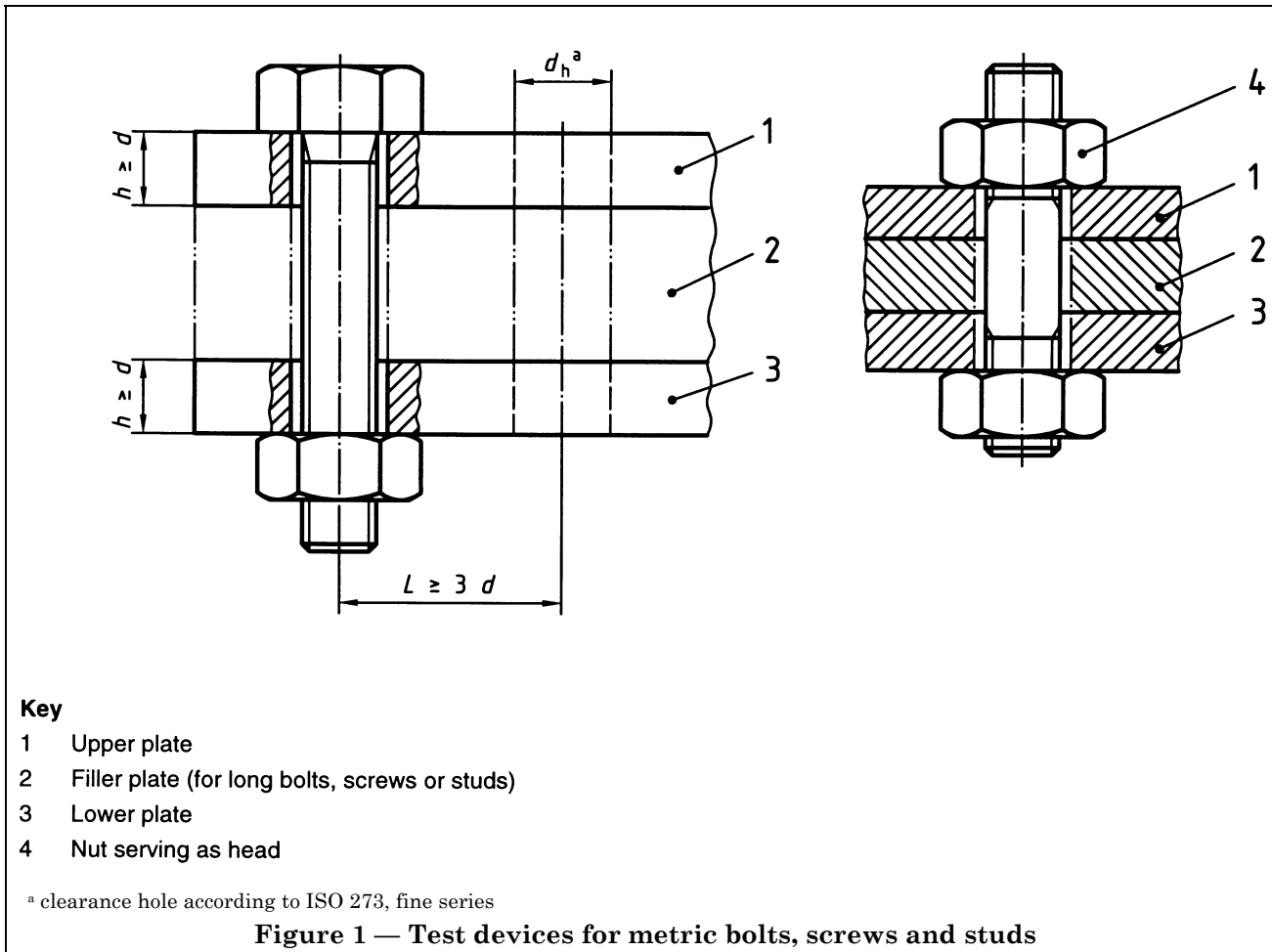

3.3 manufacturing lot

quantity of fasteners of a single designation including product grade, property class and size, manufactured from bar, wire, rod or flat product from a single cast, processed through the same or similar steps at the same time or over a continuous time period through the same heat treatment and/or coating process, if any

same heat treatment or coating process means:

- for a continuous process, the same treatment cycle without any setting modification;
- for a discontinuous process, the same treatment cycle for identical consecutive loads (batches).

NOTE The manufacturing lot may be split into a number of manufacturing batches for processing purposes and then reassembled into the same manufacturing lot.

3.4 manufacturing batch

quantity of identical fasteners from the same manufacturing lot processed together at one time

4 Principle

The preloading test is carried out in suitable test devices. The fasteners are subjected to stress in the range of the yield point or the breaking torque either by torquing with a mating nut (or bolt) or by driving in a pretapped plate, see Figure 1 to Figure 3. Other loading systems and fixtures are permissible, provided that the required stress in the range of the yield point or breaking torque of the relevant fastener can be achieved. The stress or torque is held at least for 48 h. After every 24 h the fasteners are retightened to the initial stress or torque and at the same time checked if failure due to hydrogen embrittlement has occurred.

5 Test apparatus

According to the different types of fasteners different test devices shall be used.

5.1 Metric bolts, screws and studs

For metric bolts, screws and studs fixtures of hardened plates of steel with parallel faces and with one hole or with multiple holes perpendicular to the surfaces of the plates shall be used, see Figure 1.

The apparatus for metric bolts, screws and studs comprises a top and a bottom steel plate, see Figure 1. The hardness of top plate and bottom plate shall be 45 HRC minimum. The bearing surfaces shall be ground, and the roughness shall not exceed $R_a = 8 \mu\text{m}$. The thickness of each plate shall be $1d$ minimum (d is the nominal thread diameter). The clearance holes shall have diameters d_h in accordance with ISO 273, fine series, and shall not be chamfered. The distance of the clearance holes, L , from each other shall be three diameters ($3d$) minimum.

When carrying out the test, a free threaded length of at least $1d$ shall be subjected to stress, and no more than 5 full threads shall extend beyond the nut. To meet these requirements, one or more plates of steel with parallel and ground faces may be used as filler plate(s). The filler plate(s) may be manufactured from other steel grades and with a different hardness compared to upper and bottom plate.

The bolts, screws and studs to be tested are preloaded by tensioning with a mating nut. In the case of studs or threaded rod, nuts shall be used at both sides of the test plate(s). When they are threaded with different pitch threads, the nut on the fine thread shall be considered as the head. The nut representing the head shall be screwed to finger tightness up to the relevant thread end.

In the case of a short screw ($l < 2,5 d$) only one plate with pretapped holes shall be used in which the screw shall be screwed directly without using a nut and tightened against the screw head. The plate shall have the properties as specified above for the top plate.

For testing bolts and screws with no flat bearing surface (e.g. countersunk screws, eye bolts etc.) an appropriate upper plate or washer shall be used under the head, see Figure 2.

5.2 Thread rolling screws, self-tapping screws and self-drilling screws

The apparatus for thread rolling screws, self-tapping screws and self-drilling screws comprises a plate made from steel with mechanical properties as specified for the corresponding drive test in ISO 7085, ISO 2702 or ISO 10666 respectively, but which is pretapped, see Figure 3. A suitable washer of hardness class 300 HV may be applied under the head of the screw to protect the plate. The minimum thickness of the plate shall be $1d$ ($d =$ nominal thread diameter). All other requirements are the same as for metric bolts, screws and studs, see 5.1.

NOTE Instead of using taps, pretapping can be achieved by driving the screws to be tested through holes with diameters according to the relevant International Standards (see above), provided that the thread of the screw is long enough to complete the tapping of the mating thread. When the thread is completed, the required torque to continue the driving process is markedly reduced and is not increased as long as the clamping process is not started.

For the testing of long screws, one or more plates of steel with parallel and surface ground faces may be used as filler plates. The diameter of the clearance hole in the plates shall not exceed the nominal thread diameter by more than 10 %.

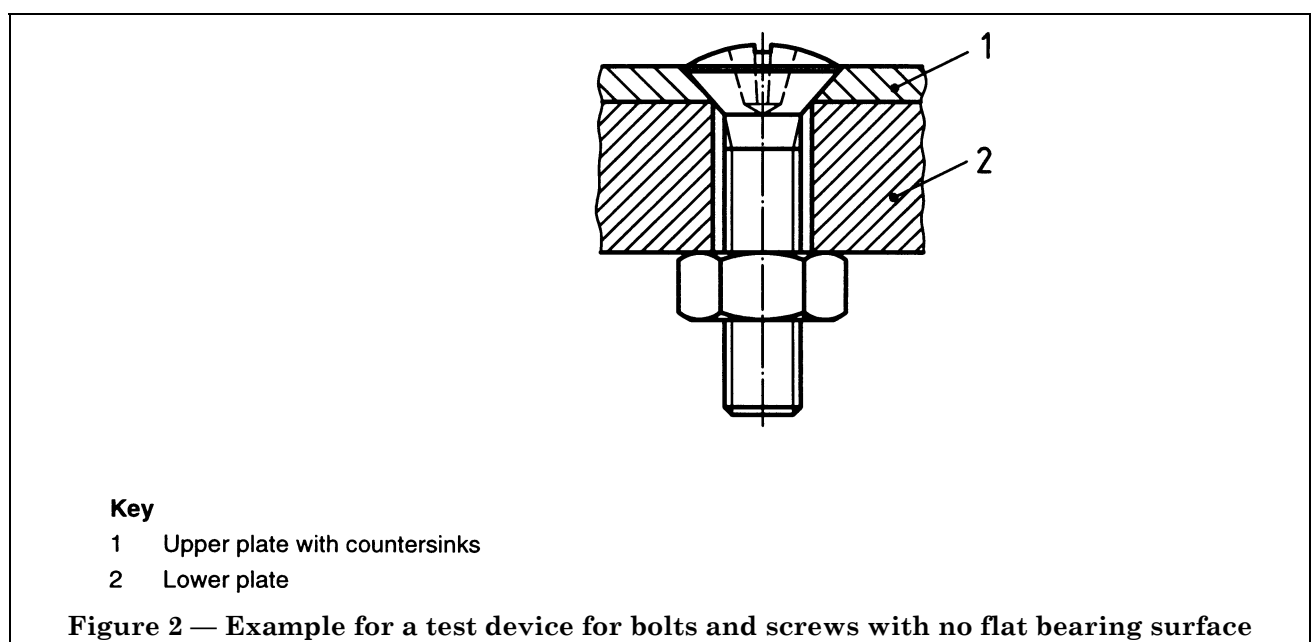

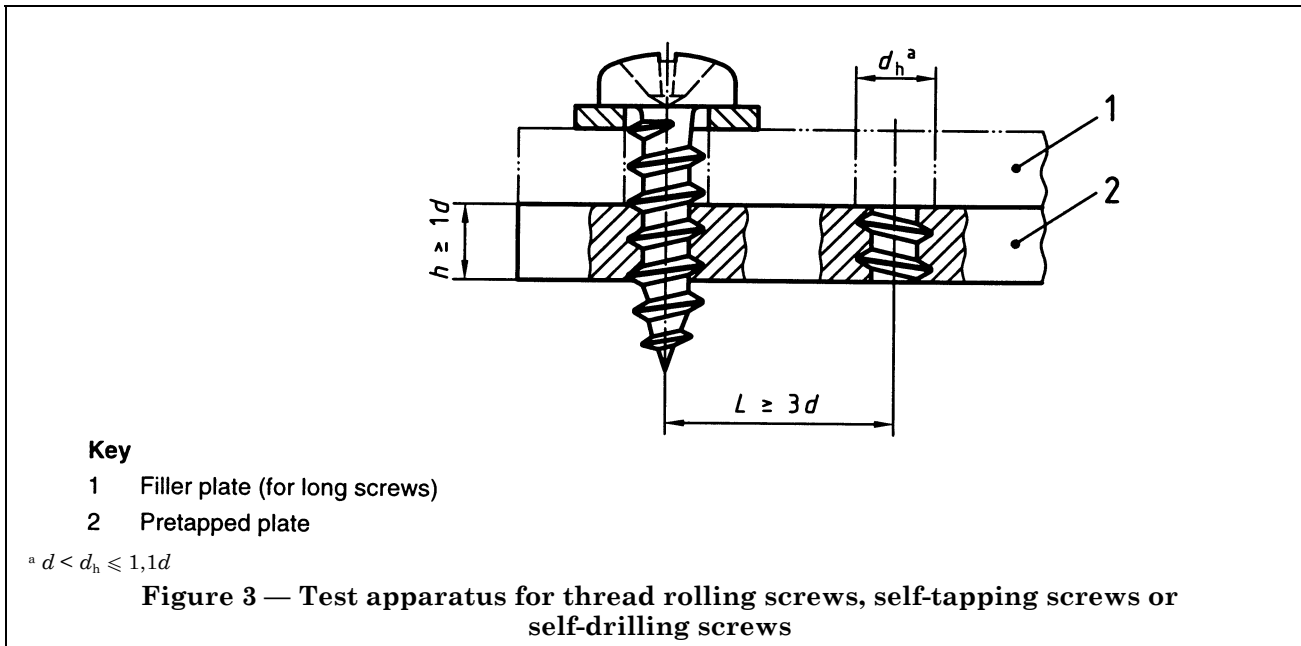

5.3 Screw and washer assemblies

The testing of screw and washer assemblies shall be carried out using the relevant apparatus described in 5.1 or 5.2.

5.4 Nuts

It should be recognized that certain nuts may be subjected to tensile stress in the bearing surface area due to widening. This can apply to flanged nuts or other unusually shaped nuts, but also for common nuts. Thus, testing of nuts shall be taken into consideration as agreed between the manufacturer and the processor.

The apparatus for testing nuts is the same as described in 5.1.

5.5 Spring washers

Several spring washers shall be stacked on a bolt of nominal thread diameter according to the nominal diameter of the spring washers. The spring washers to be tested shall be separated from each other by plain washers. The plain washers shall have a hardness greater than the hardness of the washers being tested and shall be a minimum of 40 HRC.

When testing conical spring washers they shall be tested in pairs as shown in Figure 4.

The assembly shall be tightened until a sufficient load is generated to flatten the spring washers.

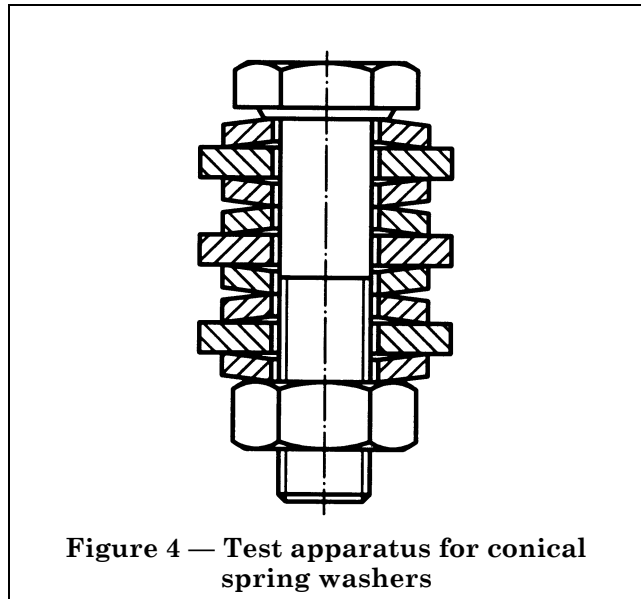

6 Sampling

For the in-process control, a suitable sampling plan shall be used as agreed between the manufacturer and the party responsible for a particular step of the process (e.g. hardener or coater) or between the responsible departments of a company. The sampling plan shall be chosen for each manufacturing batch.

The parts of the sample shall be examined without supplementary magnification for visible cracks.

7 Test procedure

7.1 Lubrication

Bolts, screws, studs and nuts shall be lubricated prior to testing to improve the reliability of the test.

NOTE With suitable lubrication (for example oil or any lubricant without sulfur), more uniform friction coefficients are achieved. Moreover, lubricant lowers the induced torsion enabling a higher tensile load to be achieved.

7.2 Application of preload

Great care should be taken when applying this test. Embrittled fasteners may suddenly break and cause severe injury. Hence, shields or other appropriate apparatus should be provided to avoid such injury.

The maximum tightening speed shall be $0,33 \text{ s}^{-1}$ (20 rpm).

7.2.1 Metric bolts, screws, studs and nuts

Metric bolts, screws or studs shall be assembled with mating nuts and tightened with a suitable torque wrench up to the yield point. Tightening to the yield point may be achieved by various techniques such as:

- monitoring the torque angle gradient or
- tightening to a predetermined torque then rotating through a predetermined angle.

The nuts used for the test shall be from a single manufacturing lot; they may be uncoated or coated, but shall be uniform.

Nuts shall be assembled with mating bolts or screws and tightened up to the yield point. The bolts or screws used for the test shall be from a single manufacturing lot; they may be coated or uncoated, but shall be uniform.

The preload shall be applied according to the following procedure.

- a) Mount 5 bolts or screws in the test plates and assemble the nuts until they are seated against the test plate surface.
- b) Tighten the assemblies up to the individual yield point. Tightening may be applied over the nut or over the head of the bolt or screw at the discretion of the tester, but shall be uniform with regard to all fasteners tested.
- c) Record the torque values at the yield point of the five fastener assemblies and calculate the average and the difference between the maximum and the minimum value. If this difference is less than 15 % of the average value, the average value shall be the test tightening torque for the specified sample (see clause 6). In the case of a difference in excess of 15 % the specified number of fasteners shall be tightened to their individual yield point.

- d) Tighten the specified number of fasteners up to the test tightening torque or to the individual yield point in accordance with paragraphs a) to c).

7.2.2 Thread rolling screws, self-tapping screws and self-drilling screws

Thread rolling screws, self-tapping screws or self-drilling screws shall be tightened with a suitable torque wrench up to 90 % of the smallest value of breaking torques received from tests on 5 screws. The following procedure shall be applied.

- a) Drive five screws (possibly with plain washers) into the test plate until the head is seated against the plate surface.
- b) Tighten the screws up to their individual breaking torque and record the values. Take the smallest of the values and multiply it by 0,9 (90 %) to establish the test tightening torque for the specified sample (see clause 6). The difference between the maximum and the minimum breaking torque received on the five screws shall be not more than 15 % of the minimum value.

NOTE If the difference is more than 15 %, this test may not be able to detect hydrogen embrittlement.

Where the head style or driving feature (cross recess, slot, shallow recess) prevents the screw from being able to be tightened to the breaking point, the test tightening torque shall be 90 % of the lowest drive failure torque.

- c) Tighten the specified number of fasteners up to the test tightening torque in accordance with paragraph b).

7.2.3 Spring washers

The preload shall be applied according to the following procedure.

- a) Mount the spring washers on the test bolt as described in 5.5 and screw the test nut until it is seated against the first washer.
- b) Tighten the assembly until the spring washers are flattened.

7.3 Reference test

The occurrence of cracks, separated heads or breakage of fasteners when subjected to stress or during the test need not necessarily be due to hydrogen embrittlement resulting from a coating process. A test with uncoated fasteners (reference test) may be undertaken and will give an indication whether there are other steps within the manufacturing process that can cause brittle fracture.

Sampling for a reference test shall be agreed between the parties as described in clause 6. Test procedure shall be in accordance with 7.2.1 to 7.2.3.

7.4 Time for starting the test

The sensitivity of the preloading test depends on the time of starting the test. Therefore, this test should be carried out as soon as possible, preferably within 24 h after the step of the manufacturing process which is under investigation.

NOTE If there is hydrogen embrittlement which could easily be discovered by carrying out the test immediately, an extension of starting time up to several days or even one week or more will reduce the chance of detecting hydrogen embrittlement considerably.

7.5 Retightening during test

The minimum test duration shall be 48 h. The fastener shall be retightened at least every 24 h to the test tightening torque or load originally applied. If the loss of torque is more than 50 % for at least one fastener then the test shall be restarted with the same fasteners.

Prior to completion of the test a final retightening shall be performed. Prior to the final retightening, fasteners shall be unscrewed approximately 1/2 turn in order to recognize whether or not fracture has occurred within the engaged part of the thread.

8 Test evaluation

Parts shall be examined, without supplementary magnification after the preloading test. To pass this test, there shall be no visible cracks or breakage of any of the fasteners tested.

9 Test report

The test report shall state

- a) the number of this International Standard, i.e. ISO 15330;
- b) the batch or lot identification;
- c) the number of fasteners tested;
- d) the process being investigated;
- e) the number and timing of retightening operations;
- f) the test duration;
- g) the number of broken or obviously failed fasteners from the reference test, if made;
- h) the number of broken or obviously failed fasteners from the process test;
- i) duration between the end of the manufacturing process or the process step and the beginning of the test (if known).

Bibliography

[1] ISO 9587:—, *Metallic and other inorganic coatings — Pretreatments of iron or steel to reduce the risk of hydrogen embrittlement*¹⁾.

¹⁾ To be published.

Annex ZA (normative)**Normative references to international publications with their relevant European publications**

This European Standard incorporates by dated or undated reference, provisions from other publications. These normative references are cited at the appropriate places in the text and the publications are listed hereafter. For dated references, subsequent amendments to or revisions of any of these publications apply to this European Standard only when incorporated in it by amendment or revision. For undated references the latest edition of the publication referred to applies.

Publication	Year	Title	EN	Year
ISO 273	1979	<i>Fasteners — Clearance holes for bolts and screws</i>	EN 20273	1991
ISO 2702	1992	<i>Heat-treated steel tapping screws — Mechanical properties</i>	EN ISO 2702	1994
ISO 7085	1999	<i>Mechanical and performance requirements of case hardened and tempered metric thread rolling screws</i>	EN ISO 7085	1999
ISO 10666	1999	<i>Drilling screws with tapping screw thread — Mechanical and functional properties</i>	EN ISO 10666	1999

BSI — British Standards Institution

BSI is the independent national body responsible for preparing British Standards. It presents the UK view on standards in Europe and at the international level. It is incorporated by Royal Charter.

Revisions

British Standards are updated by amendment or revision. Users of British Standards should make sure that they possess the latest amendments or editions.

It is the constant aim of BSI to improve the quality of our products and services. We would be grateful if anyone finding an inaccuracy or ambiguity while using this British Standard would inform the Secretary of the technical committee responsible, the identity of which can be found on the inside front cover. Tel: 020 8996 9000. Fax: 020 8996 7400.

BSI offers members an individual updating service called PLUS which ensures that subscribers automatically receive the latest editions of standards.

Buying standards

Orders for all BSI, international and foreign standards publications should be addressed to Customer Services. Tel: 020 8996 9001. Fax: 020 8996 7001.

In response to orders for international standards, it is BSI policy to supply the BSI implementation of those that have been published as British Standards, unless otherwise requested.

Information on standards

BSI provides a wide range of information on national, European and international standards through its Library and its Technical Help to Exporters Service. Various BSI electronic information services are also available which give details on all its products and services. Contact the Information Centre. Tel: 020 8996 7111. Fax: 020 8996 7048.

Subscribing members of BSI are kept up to date with standards developments and receive substantial discounts on the purchase price of standards. For details of these and other benefits contact Membership Administration. Tel: 020 8996 7002. Fax: 020 8996 7001.

Copyright

Copyright subsists in all BSI publications. BSI also holds the copyright, in the UK, of the publications of the international standardization bodies. Except as permitted under the Copyright, Designs and Patents Act 1988 no extract may be reproduced, stored in a retrieval system or transmitted in any form or by any means – electronic, photocopying, recording or otherwise – without prior written permission from BSI.

This does not preclude the free use, in the course of implementing the standard, of necessary details such as symbols, and size, type or grade designations. If these details are to be used for any other purpose than implementation then the prior written permission of BSI must be obtained.

If permission is granted, the terms may include royalty payments or a licensing agreement. Details and advice can be obtained from the Copyright Manager. Tel: 020 8996 7070.