

BS EN ISO 15008:2017



BSI Standards Publication

Road vehicles — Ergonomic aspects of transport information and control systems — Specifications and test procedures for in-vehicle visual presentation (ISO 15008:2017)

National foreword

This British Standard is the UK implementation of EN ISO 15008:2017. It supersedes BS EN ISO 15008:2009 which is withdrawn.

The UK participation in its preparation was entrusted to Technical Committee AUE/12, Ergonomics (Road vehicles).

A list of organizations represented on this committee can be obtained on request to its secretary.

This publication does not purport to include all the necessary provisions of a contract. Users are responsible for its correct application.

© The British Standards Institution 2017.
Published by BSI Standards Limited 2017

ISBN 978 0 580 86378 3

ICS 13.180; 43.040.15

Compliance with a British Standard cannot confer immunity from legal obligations.

This British Standard was published under the authority of the Standards Policy and Strategy Committee on 31 March 2017.

Amendments/corrigenda issued since publication

Date	Text affected
------	---------------

EUROPEAN STANDARD

EN ISO 15008

NORME EUROPÉENNE

EUROPÄISCHE NORM

March 2017

ICS 13.180; 43.040.15

Supersedes EN ISO 15008:2009

English Version

**Road vehicles - Ergonomic aspects of transport
information and control systems - Specifications and test
procedures for in-vehicle visual presentation (ISO
15008:2017)**

Véhicules routiers - Aspects ergonomiques des
systèmes de commande et d'information des
transports - Spécifications et modes opératoires pour
la présentation visuelle à bord du véhicule (ISO
15008:2017)

Straßenfahrzeuge - Ergonomische Aspekte von
Fahrerinformations- und Assistenzsystemen -
Anforderungen und Bewertungsmethoden der
visuellen Informationsdarstellung im Fahrzeug (ISO
15008:2017)

This European Standard was approved by CEN on 25 February 2017.

CEN members are bound to comply with the CEN/CENELEC Internal Regulations which stipulate the conditions for giving this European Standard the status of a national standard without any alteration. Up-to-date lists and bibliographical references concerning such national standards may be obtained on application to the CEN-CENELEC Management Centre or to any CEN member.

This European Standard exists in three official versions (English, French, German). A version in any other language made by translation under the responsibility of a CEN member into its own language and notified to the CEN-CENELEC Management Centre has the same status as the official versions.

CEN members are the national standards bodies of Austria, Belgium, Bulgaria, Croatia, Cyprus, Czech Republic, Denmark, Estonia, Finland, Former Yugoslav Republic of Macedonia, France, Germany, Greece, Hungary, Iceland, Ireland, Italy, Latvia, Lithuania, Luxembourg, Malta, Netherlands, Norway, Poland, Portugal, Romania, Serbia, Slovakia, Slovenia, Spain, Sweden, Switzerland, Turkey and United Kingdom.



EUROPEAN COMMITTEE FOR STANDARDIZATION
COMITÉ EUROPÉEN DE NORMALISATION
EUROPÄISCHES KOMITEE FÜR NORMUNG

CEN-CENELEC Management Centre: Avenue Marnix 17, B-1000 Brussels

European foreword

This document (EN ISO 15008:2017) has been prepared by Technical Committee ISO/TC 22 “Road vehicles” in collaboration with Technical Committee CEN/TC 278 “Intelligent transport systems” the secretariat of which is held by NEN.

This European Standard shall be given the status of a national standard, either by publication of an identical text or by endorsement, at the latest by September 2017, and conflicting national standards shall be withdrawn at the latest by September 2017.

Attention is drawn to the possibility that some of the elements of this document may be the subject of patent rights. CEN [and/or CENELEC] shall not be held responsible for identifying any or all such patent rights.

This document supersedes EN ISO 15008:2009.

According to the CEN-CENELEC Internal Regulations, the national standards organizations of the following countries are bound to implement this European Standard: Austria, Belgium, Bulgaria, Croatia, Cyprus, Czech Republic, Denmark, Estonia, Finland, Former Yugoslav Republic of Macedonia, France, Germany, Greece, Hungary, Iceland, Ireland, Italy, Latvia, Lithuania, Luxembourg, Malta, Netherlands, Norway, Poland, Portugal, Romania, Serbia, Slovakia, Slovenia, Spain, Sweden, Switzerland, Turkey and the United Kingdom.

Endorsement notice

The text of ISO 15008:2017 has been approved by CEN as EN ISO 15008:2017 without any modification.

Contents

Page

Foreword	iv
Introduction	v
1 Scope	1
2 Normative references	1
3 Terms and definitions	1
4 Requirements and measurement methods	4
4.1 General.....	4
4.2 Design viewing position and illumination range.....	5
4.2.1 Design viewing position.....	5
4.2.2 Illumination range.....	7
4.3 Display illumination, minimum contrast, luminance and polarity.....	7
4.3.1 Display illumination.....	7
4.3.2 Minimum contrast ratio.....	7
4.3.3 Display mode.....	10
4.4 Colour combinations.....	10
4.5 Alphanumerical character dimensions.....	11
4.5.1 General.....	11
4.5.2 Height.....	11
4.5.3 Width by height ratio: Proportion of the typeface.....	11
4.5.4 Stroke width by height ratio: Weight of the typeface.....	12
4.5.5 Spacing.....	12
4.5.6 Case.....	13
4.6 Pixel matrix character format.....	14
4.6.1 Upper and lower case of alphanumeric Latin, Greek, Cyrillic characters.....	14
4.6.2 Automotive symbols.....	15
4.6.3 Non-Latin characters.....	16
4.7 Reflections and glare.....	16
4.8 Characteristics of presentation.....	16
4.8.1 Image instability.....	16
4.8.2 Image flashing.....	16
4.9 Redundant information displays.....	17
Annex A (normative) Definition and measurement of character dimensions	18
Annex B (informative) Colour combinations	20
Annex C (informative) Terminology of typographic terms and visual dictionary	21
Bibliography	25

Foreword

ISO (the International Organization for Standardization) is a worldwide federation of national standards bodies (ISO member bodies). The work of preparing International Standards is normally carried out through ISO technical committees. Each member body interested in a subject for which a technical committee has been established has the right to be represented on that committee. International organizations, governmental and non-governmental, in liaison with ISO, also take part in the work. ISO collaborates closely with the International Electrotechnical Commission (IEC) on all matters of electrotechnical standardization.

The procedures used to develop this document and those intended for its further maintenance are described in the ISO/IEC Directives, Part 1. In particular the different approval criteria needed for the different types of ISO documents should be noted. This document was drafted in accordance with the editorial rules of the ISO/IEC Directives, Part 2 (see www.iso.org/directives).

Attention is drawn to the possibility that some of the elements of this document may be the subject of patent rights. ISO shall not be held responsible for identifying any or all such patent rights. Details of any patent rights identified during the development of the document will be in the Introduction and/or on the ISO list of patent declarations received (see www.iso.org/patents).

Any trade name used in this document is information given for the convenience of users and does not constitute an endorsement.

For an explanation on the meaning of ISO specific terms and expressions related to conformity assessment, as well as information about ISO's adherence to the World Trade Organization (WTO) principles in the Technical Barriers to Trade (TBT) see the following URL: www.iso.org/iso/foreword.html.

The committee responsible for this document is ISO/TC 22, *Road vehicles*, Subcommittee SC 39, *Ergonomics*.

This third edition cancels and replaces the second edition (ISO 15008:2009), which has been technically revised with the following changes:

- Introduction was modified;
- Scope was modified (heavy vehicles partly excluded);
- test conditions for direct sunlight have been changed;
- character height was modified;
- character proportion was modified;
- character weight criterion was modified;
- intercharacter spacing was modified;
- word spacing was modified;
- a new subclause on text case was added;
- the subclause on character outlines was modified;
- a new subclause on character shadows was added;
- the subclause on Non-Roman text was modified and renamed Non-Latin.

Introduction

Driving is a complex task requiring continuous allocation of attentional resources to both driving and non-driving tasks. Because of this, driving is an interactive balance between cognitive, physical, somatosensory, visual and psychomotor skills.

Driver and vehicle form an integrated system that includes the environment, vehicle controls, and displays collectively defined as the transport information and control systems (TICS). Since driving is an interactive systems activity, vehicle characteristics in combination with human capabilities constitute important factors in the performance of this TIC system.

In order to achieve optimal driver performance, the purpose of TICS is to support drivers in their primary task such that performance, comfort and safety are increased and overall driver workload is not negatively influenced by the use of TICS. One set of factors influencing this process involves the characteristics of visual displays. Specifically, those aspects of displays designed to accommodate human capabilities, the range of illumination conditions and location of the display with respect to the driver. This is especially important since visual specifications must include a wide range of environmental conditions and constitute only one necessary condition for adequate performance, comfort and workload. The purpose of this document is to standardize visual presentation.

Road vehicles — Ergonomic aspects of transport information and control systems — Specifications and test procedures for in-vehicle visual presentation

1 Scope

This document specifies minimum requirements for the image quality and legibility of displays containing dynamic (changeable) visual information presented to the driver of a passenger car by on-board transport information and control systems (TICS) used while the vehicle is in motion. Heavy vehicles are excluded for the requirements of contrast and font size since these chapters reference ISO 4513 which is only applicable for passenger vehicles. These requirements are intended to be independent of display technologies. Reference to test methods and measurements for assessing compliance with them have been included where necessary.

This document is applicable mainly to perceptual, and some basic cognitive, components of the visual information, including character legibility and colour recognition. It is not applicable to other factors affecting performance and comfort, such as coding, format and dialogue characteristics, or to displays using:

- characters presented as a part of a symbol or pictorial information (e.g. CD symbol);
- superimposed information on the external field (e.g. head-up displays);
- pictorial images (e.g. rear view camera);
- maps and topographic representations (e.g. those for setting navigation systems); or
- quasi-static information (e.g. AM/PM, km/miles, kPa/PSI, On/Off information).

2 Normative references

The following documents are referred to in the text in such a way that some or all of their content constitutes requirements of this document. For dated references, only the edition cited applies. For undated references, the latest edition of the referenced document (including any amendments) applies.

ISO 4513, *Road vehicles — Visibility — Method for establishment of eyellipses for driver's eye location*

CIE 85:1989, *Solar spectral irradiance*

SAE J1757/1:2015, *Standard Metrology for Vehicular Displays*

CIE S 017/E:2011 ILV, *International lighting vocabulary*

3 Terms and definitions

For the purposes of this document, the terms and definitions given in CIE S 017/E:2011 ILV and the following apply.

ISO and IEC maintain terminological databases for use in standardization at the following addresses:

- IEC Electropedia: available at <http://www.electropedia.org/>
- ISO Online browsing platform: available at <http://www.iso.org/obp>

**3.1
adaptation**

adjustment of the eye's sensitivity to the *brightness* (3.2) of the observed visual field by chemical and physical processes within the eye

Note 1 to entry: Dark adaptation occurs at a slower rate than does light adaptation.

**3.2
brightness**

subjective attribute of light sensation by which a stimulus appears to be more or less intense or to emit more or less light

**3.3
chromatic**

having hue or being coloured, appearing different in quality from a neutral grey having the same *brightness* (3.2)

Note 1 to entry: It is related to the colour properties of a visual stimulus.

**3.4
contrast ratio**

R_c
ratio between the luminance L_{high} and the luminance L_{low}

Note 1 to entry: $R_c = \frac{L_{\text{high}}}{L_{\text{low}}}$.

Note 2 to entry: Terms and definitions related to photometric quantities (e.g. illuminance, luminance, luminance contrast and saturation) are given in CIE S 017/E:2011 ILV. In CIE S 017/E:2011 ILV, it is referred as luminance contrast ratio.

**3.5
critical specular line**

CSL
line from the centre of the display to the centre of the *eyellipse* (3.10)

**3.6
cyclopean eyellipse**

elliptical volume combining the left and the right *eyellipse* (3.10) of the driver into one single volume located in the centre between them

**3.7
day condition**

condition with diffuse ambient light

**3.8
direct sunlight condition**

condition under which the viewing conditions are mainly influenced by direct light from the sun on the display surface

**3.9
dynamic information**

information that has more than two stages of change

**3.10
eyellipse**

elliptical shape of the driver eye range

Note 1 to entry: As defined in ISO 4513.

Note 2 to entry: See definition of 95th percentile eyellipse in ISO 4513.

Note 3 to entry: It is the contraction of the words “eye” and “ellipse”.

**3.11
flash**

intended periodic variation of the luminance of a light or visual information, normally from “OFF” to a given value, typically used for attracting attention

Note 1 to entry: Terms and definitions related to photometric quantities (e.g. illuminance, luminance, luminance *contrast ratio* (3.4), saturation) are given in CIE S 017/E:2011 ILV.

**3.12
flicker**

unintended perceived temporal variation of the *brightness* (3.2) of a visual stimulus, usually generated by refresh process of the display content or by variation of the luminance of the backlight

Note 1 to entry: Terms and definitions related to photometric quantities (e.g. illuminance, luminance, luminance *contrast ratio* (3.4), saturation) are given in CIE S 017/E:2011 ILV.

**3.13
disability glare**

dazzling or disabling effect produced by a bright light

Note 1 to entry: This is a retinal effect, primarily caused by light scatter in the eye, which produces a luminous veil over the retinal image and thus reduces contrast.

**3.14
discomfort glare**

distracting or disrupting effect of bright point sources in the field of view

Note 1 to entry: This is a perceptual effect, interfering with visual attention and selection.

**3.15
jitter**

unintended periodic movement of an image or parts of it

**3.16
legibility**

visual properties of a character or graphics representation that determine the ease with which it can be recognized

Note 1 to entry: See also *readability* (3.21).

**3.17
map**

representation on plane surface of the features of a connected part of the earth surface (especially of the road and traffic environment), shown in their representative forms, sizes and relationship in accordance with some convention of representation

**3.18
night condition**

condition of low ambient illumination under which the *adaptation* (3.1) level of the driver is mainly influenced by the portion of the road ahead covered by the vehicle’s own headlights and surrounding street lights, and display and instrument *brightness* (3.2)

Note 1 to entry: Low ambient illumination is less than 50 lx.

**3.19
pixel**

smallest selectively addressable element of the display surface capable of reproducing the full range of luminance and colours

Note 1 to entry: “Pixel” is an abbreviated term for “picture element”.

Note 2 to entry: Terms and definitions related to photometric quantities (e.g. illuminance, luminance, luminance *contrast ratio* (3.4), saturation) are given in CIE S 017/E:2011 ILV.

3.20 quasi-static information

<reconfigurable displays> information that has a limited number of states, where one or another state is always displayed and does not change frequently

EXAMPLE AM/PM, km/miles, kPa/PSI, on/off information.

3.21 readability

visual properties of a series of characters or words that determine the ease with which they can be read

Note 1 to entry: See also *legibility* (3.16).

3.22 redundantly presented information

information which is presented in parallel by different means or at different positions

EXAMPLE 1 Speed can be displayed in both analogue and digital format.

EXAMPLE 2 Turn-by-turn navigation can be displayed on a central display and in parallel in the instrument cluster.

3.23 segment

pre-defined geometric form that can be used to create a character or symbol in whole or in part

EXAMPLE Stroke.

3.24 static information

<reconfigurable displays> information that does not change, especially physical units

EXAMPLE km, miles, kPa, PSI, mph, kph.

3.25 twilight condition

condition between *night condition* (3.18) and *day condition* (3.7)

Note 1 to entry: In twilight condition, the setting of the display illumination might be in day or night setting.

4 Requirements and measurement methods

4.1 General

The following requirements shall be complied with to ensure that images on the visual displays used in on-board TICS equipment are legible.

Conformity of the presented images to the requirements specified in this document shall be tested at an ambient temperature within the range of 18 °C to 28 °C. The test shall not start until the illumination has reached a stable state. The requirements are accompanied by standard measurement conditions in terms of ambient illuminance and observer positions. Methods for measurement of contrast shall be in accordance with SAE J1757/1.

4.2 Design viewing position and illumination range

4.2.1 Design viewing position

The requirements in this subclause are applicable to displays in their installed vehicle locations, as seen from any point in the driver eyellipses according to ISO 4513 (for passenger vehicles only).

If the display is fixed to the vehicle, the relevant requirements shall be complied with from the rearmost point of the cyclopean eyellipse. If the orientation of the display is adjustable, the display may be adjusted so that a position can be found in which all the relevant requirements are complied with simultaneously. For direct sunlight conditions, the requirements of contrast (see 4.3.2) shall only be fulfilled in the direction of the critical specular line (CSL) (see Figure 1).

Standard default values for angles ($45^\circ/20^\circ$) as an alternative for direct sunlight measurements are acceptable (see SAE J1757/1).

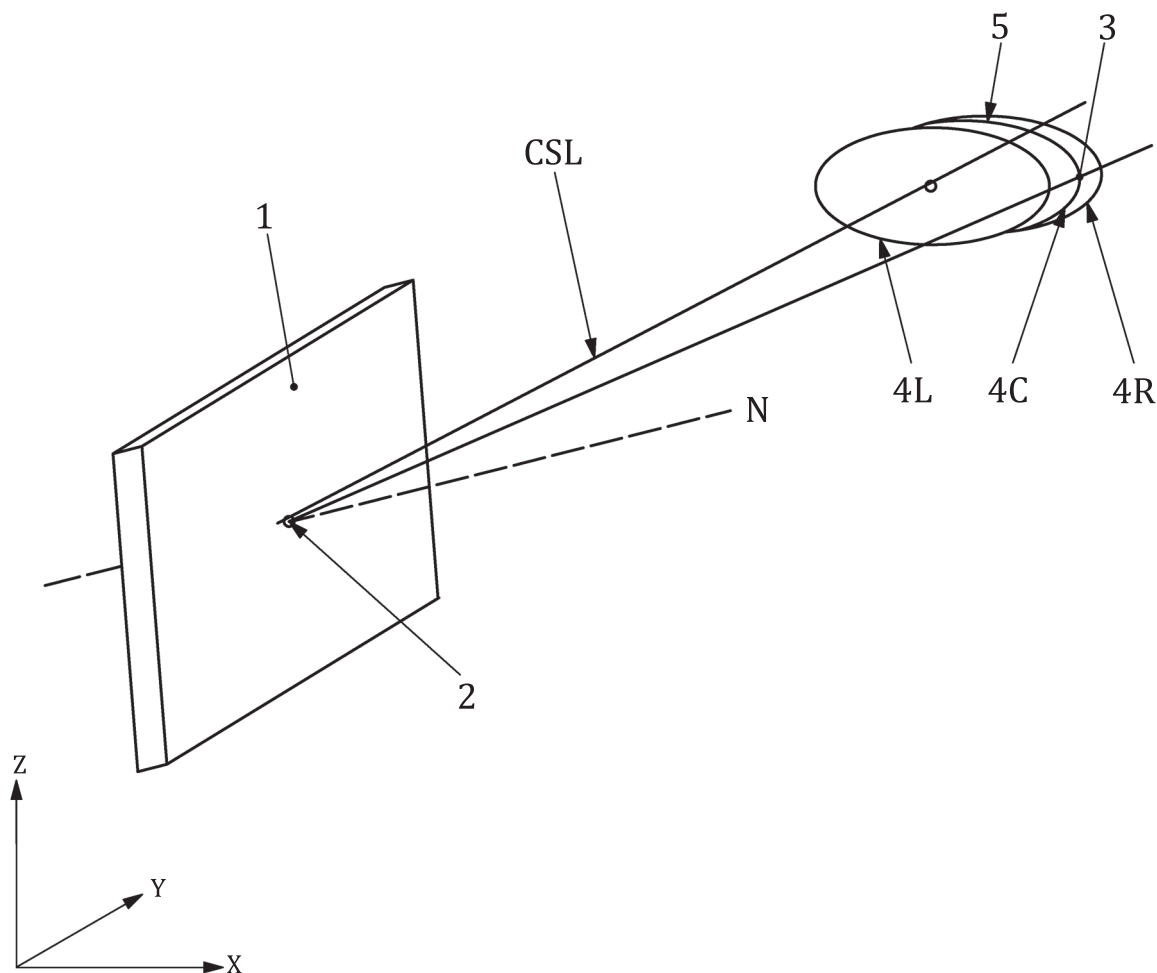

a) Display at right-hand side of driver

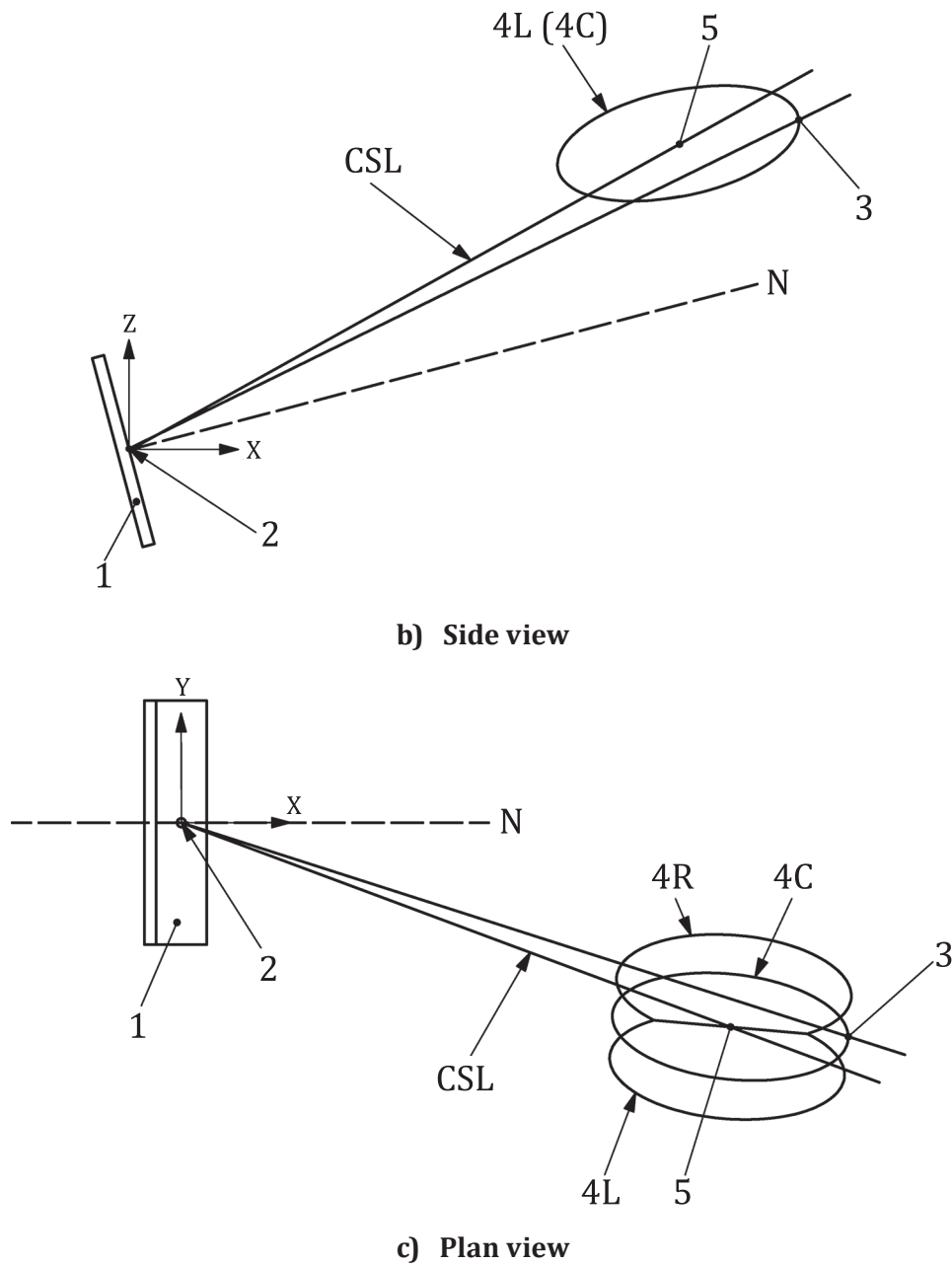

Key

- | | | | |
|----|---|----|-----------------------------------|
| 1 | display | 4L | left eyellipse |
| 2 | centre of the display | 4R | right eyellipse |
| 3 | rearmost point of the cyclopean eyellipse | 5 | centre of the cyclopean eyellipse |
| 4C | cyclopean eyellipse | N | display perpendicular direction |

Figure 1 — Design viewing position

4.2.2 Illumination range

4.2.2.1 The design illumination range establishes the four conditions of:

- night;
- twilight;
- day with diffuse ambient light; and
- day with direct sunlight.

4.2.2.2 **Night condition** is replicated in a dark environment, such that the maximum illuminance on the object to be measured shall not exceed 10 lx, with a relative tolerance of ± 5 %. For the measurement procedure, see SAE J1757/1:2015, Table 1.

4.2.2.3 **Twilight condition** is replicated with a measurement condition specified in SAE J1757/1:2015, 4.1.2.4 and Table 1. The ambient light measured on the surface of the display (on the standard diffuse reflector) shall be 250 lx, with a relative tolerance of ± 5 %. If the display setting is brought into the night-time setting manually or automatically (e.g. triggered by the head lamp switch or a sun load sensor), the displayed information shall meet the twilight requirements in 4.3.2 in the night-time setting. If the driver can manually change the setting of the display to a higher contrast, the measurement may be made in that display setting.

4.2.2.4 **Day condition with diffuse ambient light** is replicated with ambient light omni-directional to the point of measurement. The ambient light measured on the surface of the display (on the standard diffuse reflector) shall be 5 klx, with a relative tolerance of ± 5 %. For the measurement procedure, see SAE J1757/1:2015, 4.1 and Table 1.

4.2.2.5 **Direct sunlight condition** is replicated with a standard measurement condition. The illuminance at the point of measurement shall be 45 klx, with a relative tolerance of ± 5 %. For the measurement procedure, see SAE J1757/1:2015, 4.1 and Table 1.

4.2.2.6 For day and direct sunlight and for twilight conditions in the measurement procedure in accordance with SAE J1757/1, an artificial illumination system with light type similar to that of CIE 85:1989, Table 4 (± 20 %) shall be used. Light sources with large spikes in the spectrum (e.g. fluorescent lamps) should be avoided; metal halide lamps are more appropriate due to their energy in the blue part of the spectrum. The colour temperature is secondary to this issue.

4.3 Display illumination, minimum contrast, luminance and polarity

4.3.1 Display illumination

Due to the very wide range of ambient illuminations that determine the adaptation level of the driver, the display illumination should have a brightness control which allows adjustment over a suitable range.

4.3.2 Minimum contrast ratio

4.3.2.1 Requirements

The minimum contrast ratio between symbol and background shall be as follows:

- 5:1 for night condition;
- 3:1 for twilight condition;

- 3:1 for day condition;
- 2:1 for direct sunlight condition.

This is especially important if characters are close to the minimum requirements for the dimensions (see 4.5). Lower contrast should be excluded except for characters that are intentionally grey-shaded or desaturated in colour to indicate some inactive status.

4.3.2.2 Character outlining

If sufficient contrast ratio between the character and its background cannot be provided during transient states, such as dawn and dusk conditions, additional means shall be applied. This can be an outline around the character, in which case, a minimum contrast shall be provided between the body of the character/unfilled area and its outline.

The stroke width of the outline by character height ratio should be less than 0,04 for characters with serifs and less than 0,08 for characters without serifs. If the size of a character is so small that the stroke width of the outline would be less than 0,35 mm, an outline should be avoided to ensure readability (see Figure 2).

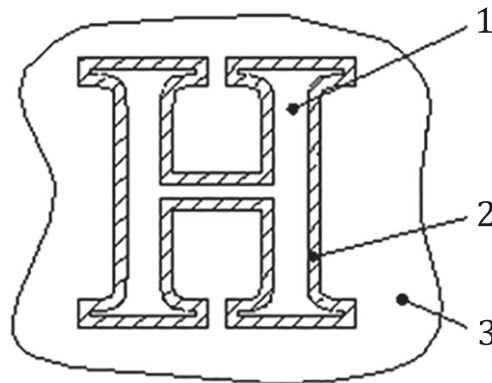

Key

- 1 body of the character/unfilled area
- 2 outline
- 3 background area

Figure 2 — Outlined character

Words or phrases written in outlined unfilled character (transparent body) fonts should not be used.

4.3.2.3 Character shadows

If sufficient contrast ratio between the character and its background cannot be provided, additional means shall be applied. In limited cases, this can be the use of a dark shadow or glow behind or around the text respectively, as long as the text and its background can still maintain 75 % of the minimum contrast. In these cases, the minimum contrast shall be provided between the body of the character/unfilled area and its shadow.

If a shadow is used, the direction of the light source shall be between 25° and 155° from horizontal (see Figure 3). Text and its background shall not be both dark in colour.

The shadow shall not be disconnected from its text, or in other words, there shall be no gap between a character and its shadow. The shadow shall not be so large that it hides relevant information in the background or fills in the insides of characters. The shadow should be soft as it smoothly fades into the background.

The width of the shadow should be less than 70 % of the stem width of the regular weight of the typeface, even when the bold weight is used (see [Figure 4](#)). The use of shadows and outlines should be restricted for use on static labels, non-dynamic text or text field titles.

25 degrees
155 degrees

Figure 3 — Shadow angles

Regular
Bold

Figure 4 — Shadow in relation to font weight

4.3.2.4 Changing background

If the background around the text or symbol is spatially changing in luminance or colour, minimum contrast ratio should be reached with the worst case background in the area adjacent to text or symbol. The contrast ratio shall be calculated from at least two measurements in different areas of the display. If the background is dynamic, an additional outline should be applied around the characters to provide a sufficient contrast ratio (see [Figure 2](#)). In this case, the contrast ratio should be measured between the outline and the borderline.

4.3.2.5 Contrast ratio measurement

All contrast measurements shall be carried out at the centre point of the cyclopean eyellipse, as shown in [Figure 1](#). For bench top measurements, standard values for angles ($45^\circ/20^\circ$) may be used for direct sunlight measurement (see SAE J1757/1). For a display in the instrument cluster, values for angles ($0^\circ/25^\circ$) can also be used.

For matrix displays, the measurements shall be taken over a collection area covering at least (3×3) pixels (see [Figure 5](#)). The measurement accuracy will be reduced if the measurement area is less than (3×3) pixels. If the area of the character to be measured does not contain at least (3×3) pixels or the photometer spot size is larger than the area of the character, find a larger area on the character that has at least (3×3) pixels and that appears visually to have the same luminance. Measure this area.

For segment displays, the measurement shall be taken within a single segment. The diameter of the collection area shall be less than 80 % of the relevant dimension of the segment to be measured.

During the contrast measurement, the display luminance should be adjusted in the night condition to “night maximum” and in daylight or direct sunlight condition to “maximum brightness”. In the twilight

condition, at least one display illumination setting (e.g. day/night setting) that meets the specified requirement when the headlamps/parking lamps are in an “ON” (or activated) state shall be provided.

For a common display that delivers different images to a driver and passengers, the contrast of the driver’s images shall be measured with the passenger’s image in fully white and in fully black. Required contrast shall be fulfilled in the worse condition.

NOTE Any ghost image from dynamic crosstalk is not covered by this document.

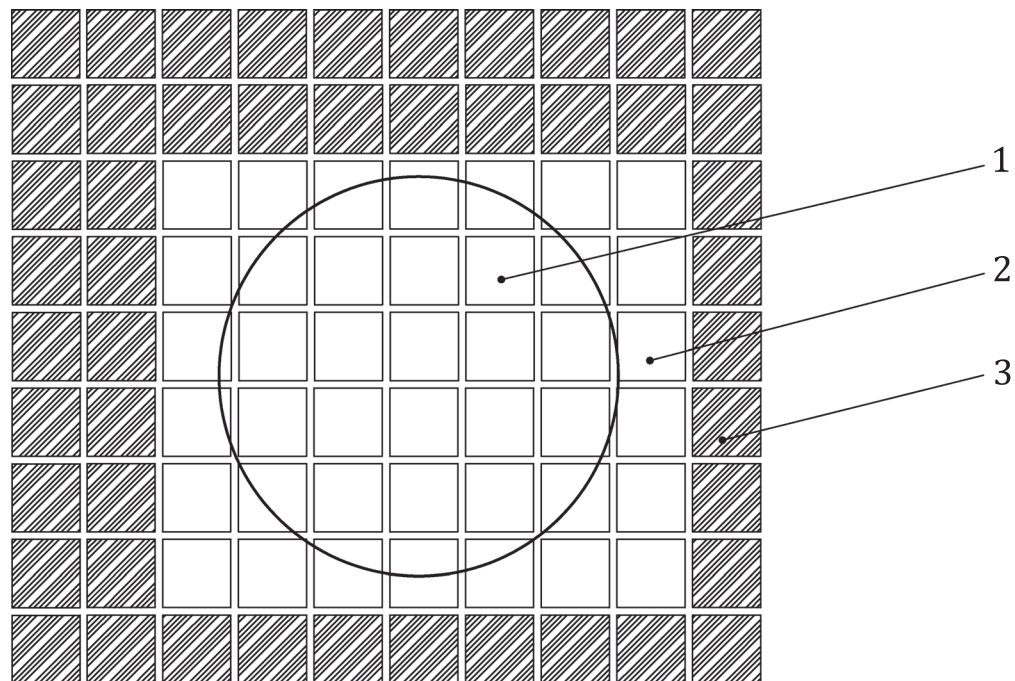

Key

- 1 collection area (photometer measurement spot)
- 2 pixel in bright state
- 3 pixel in dark state

Figure 5 — Contrast ratio measurement on matrix displays

4.3.3 Display mode

If a display shows light symbols on a dark background, this is called a negative display mode. If dark symbols are shown on a light background, this is called a positive display mode. Both display modes are known to give satisfactory performance. The choice is determined by the average luminance of those areas frequently viewed in sequence. Therefore, negative display mode should be used under the night condition. In day condition, either may be used, while taking into account the often dark immediate surroundings of displays in vehicles (e.g. the dashboard). For non-sheltered displays, positive display mode can be used for reducing the visibility of reflections. On the other hand, it should be considered that the reflections in the cab’s windshields due to positive display mode on a non-sheltered display can have an impact on the visibility on the road scene.

4.4 Colour combinations

Regardless of the colour and colour combinations between a symbol or character and its background, minimum luminance contrast ratio shall be provided (see 4.3.2).

For physiological and psychological reasons, not all symbol/background colour combinations are acceptable. Because of this, when selecting colours in full colour displays, certain symbol/background colour combinations should be chosen. For information regarding colour combinations, see Annex B.

4.5 Alphanumerical character dimensions

4.5.1 General

Definition and measurement of character dimensions shall be according to [Annex A](#). See [Annex C](#) for a terminology example.

4.5.2 Height

Latin (as well as Greek and Cyrillic) text sizes should be measured via their cap height (as in the height of “H”). It shall be measured as the subtended angle from the rearmost point of the cyclopean eyellipse and it shall be in accordance with [Table 1](#). For typefaces that have a proportion of x-height (height of “x”) to cap height that is less than 65 %, the font size should be increased so that their x-height is 70 % of the recommended cap height in [Table 1](#) in order as to compensate for the smaller optical (or perceived) size (see [Figure 6](#)).

If a font meets the requirement above for the capital letter “H”, then all other characters associated with this font, such as smaller subscripts and superscripts, may also be used.

Letters imbedded in a symbol shall be excluded from the height requirements.

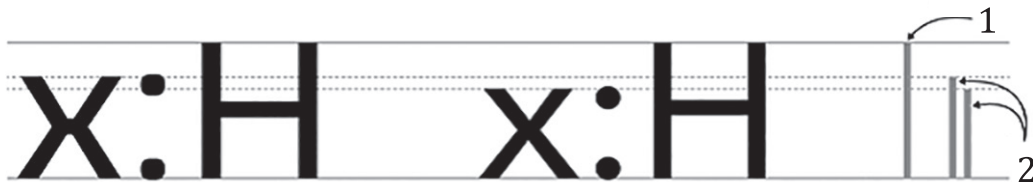

Key

- 1 cap-height
- 2 x-height

Figure 6 — Proportion of letter x to letter H

Table 1 — Character heights

Subtended angle dimension		Suitability level
in arc minutes	in radians ^a	
20	$5,815 \times 10^{-3}$	Recommended
16	$4,652 \times 10^{-3}$	Acceptable
12	$3,489 \times 10^{-3}$	Minimum ^b

^a If multiplied by the viewing distance, it gives (in the same units) the actual character height.

^b In situations when requirements for accuracy and speed of reading are modest.

4.5.3 Width by height ratio: Proportion of the typeface

Typefaces selected should not be too narrow or too wide. The proportion of the letter H (width of H divided by height of H) should be between 65 % and 80 % (see [Figure 7](#)).



Key

- 1 width
- 2 height

Figure 7 — Proportions of letter H

4.5.4 Stroke width by height ratio: Weight of the typeface

Typefaces selected should not be too light or too bold. The proportion of the stem width to the ascender height (as can be seen by dividing the width of the lower case letter L by its height) (see [Figure 8](#)) should range between 10 % and 20 %. Typefaces that fall between 8 % and 10 % can be accommodated by increasing the font size.



Key

- 1 width
- 2 height

Figure 8 — Proportions of lower case L

4.5.5 Spacing

Typefaces selected should be evenly and proportionately spaced and the space between vertical strokes (such as between l and m) should range between 150 % and 240 % of the stem width. The space between diagonal characters and a vertical (such as between v and l) should be a minimum of 85 % of the stem width. Two diagonal characters should not touch (see [Figure 9](#)).

The words space is related to the intercharacter spacing of the typeface. The proportion of word space to intercharacter space can range between 250 % and 300 % (see [Figure 10](#)).

Line spacing shall be maintained at a minimum of one average stem width. Text line spacing, T, is defined by the distance between the descender line of the current text line and the ascender line of the following text line.

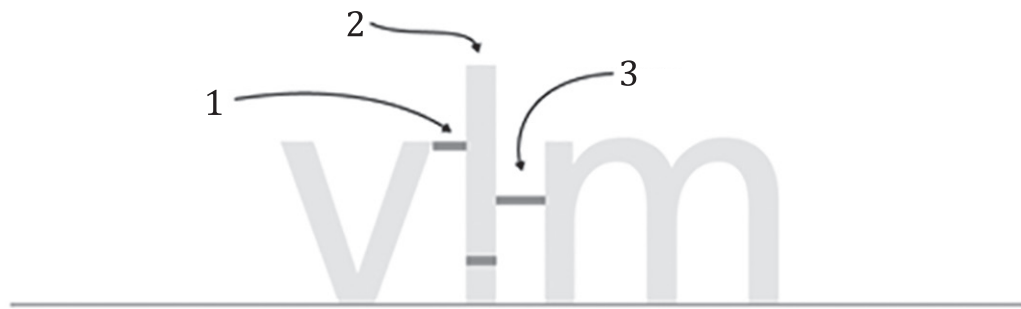

Key

- 1 vl space
- 2 stem width
- 3 lm space

Figure 9 — Inter-character spacing in relation to stem width

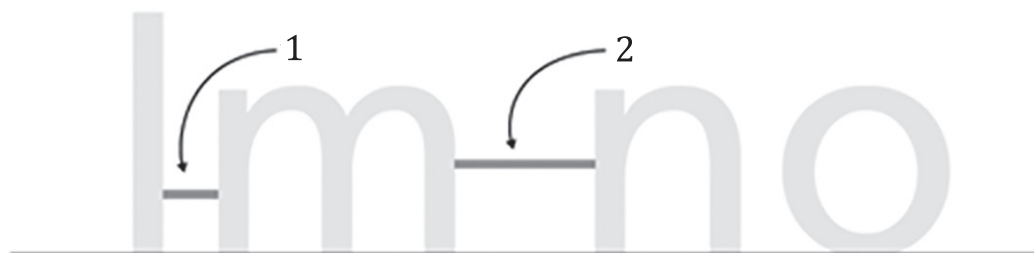

Key

- 1 lm space
- 2 space

Figure 10 — Word space in relation to inter-character spacing

4.5.6 Case

Dynamic text, especially text related to messages that are urgent in nature, should be set in mixed or lower case, unless otherwise required by the national body.

Uppercase could be used for texts that are a permanent part of the user interface (UI), such as buttons and labels, as the frequency and predictability of appearance of such text will improve the reading time required (see [Figure 11](#)).



Warning WARNING

Figure 11 — Lower case vs. upper case

4.6 Pixel matrix character format

4.6.1 Upper and lower case of alphanumeric Latin, Greek, Cyrillic characters

A (5 × 7) pixel (width by height) character matrix shall be the minimum used for alphanumeric characters, if characters are only upper case.

If legibility of an individual alphanumeric character is important for the task, a (7 × 9) pixel (width by height) character matrix should be the minimum.

If characters with descenders are used, a (7 × 11) pixel (width by height) character matrix should be the minimum.

A (4 × 5) pixel (width by height) alphanumeric character matrix shall be the minimum for the following:

- subscripts and superscripts;
- numerators and denominators of fractions displayed in a single-character position;
- information unrelated to the task (e.g. the copyright symbol, ©).

It is not necessary for the subscript or superscript to extend below or above the main character (see [Figure 12](#)).

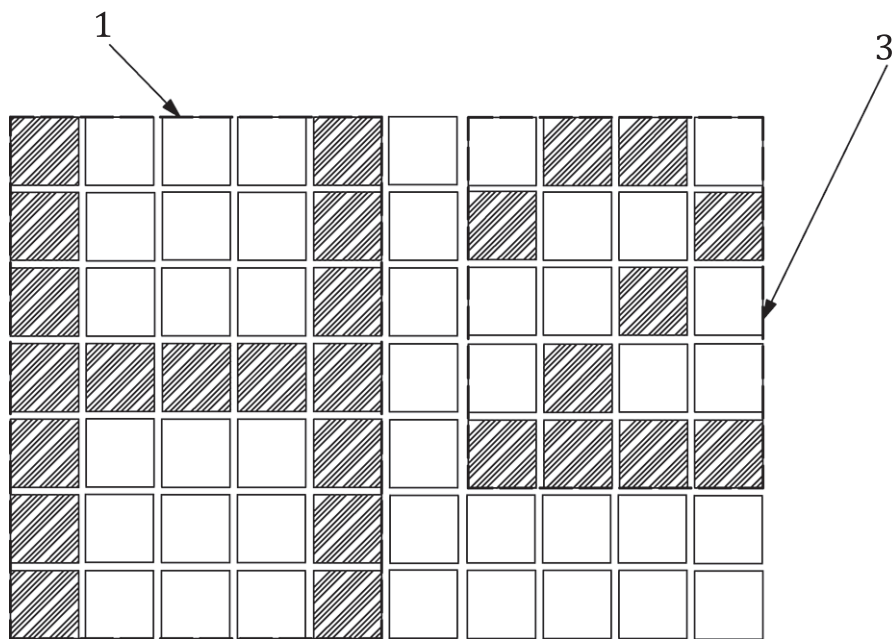
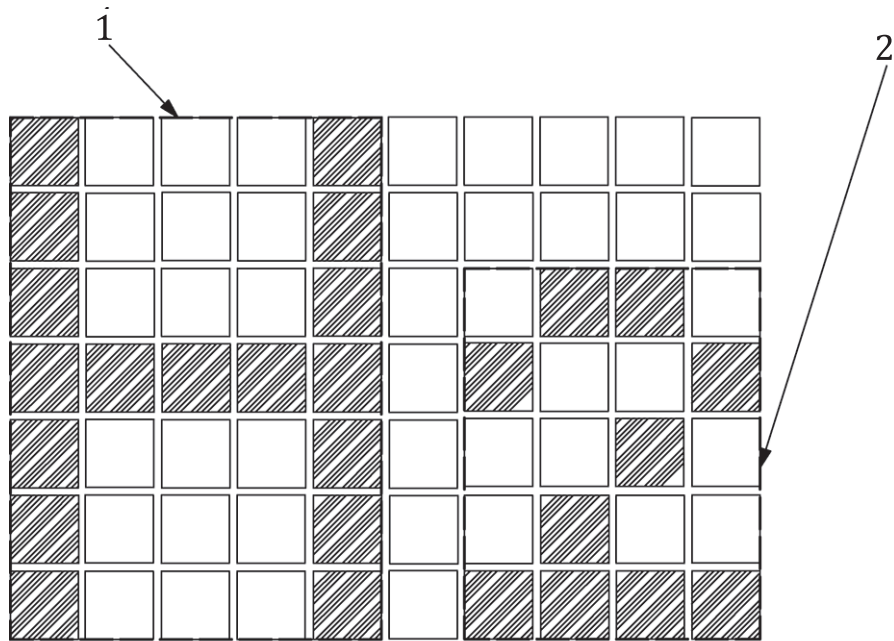

Key

- 1 (5 × 7) pixel matrix for alphanumeric character
- 2 (4 × 5) pixel matrix for subscript
- 3 (4 × 5) pixel matrix for superscript

Figure 12 — Matrix for alphanumeric character, subscript and superscript

4.6.2 Automotive symbols

For automotive symbols in accordance with ISO 2575, or similar, a (32 × 32) pixel matrix should be the minimum. A smaller matrix, e.g. (24 × 24) pixels, may be used if the display is capable of grey shades.

The number of pixels shall be determined by counting them on a suitable set of characters and symbols.

4.6.3 Non-Latin characters

This document basically refers to Latin characters as well as Greek and Cyrillic letters. This subclause gives guidance for some non-Latin characters. Other languages will be included depending on availability of sufficient knowledge.

A (16 × 16) pixel (width by height) character matrix shall be the minimum used for Chinese characters (traditional and simplified) and Japanese (Kanji) characters.

NOTE 1 Examples for (16 × 16) pixel matrices can be found in JIS X 9051.

If the legibility of an individual Chinese character or Japanese character is key to the interpretation of the message, a (24 × 24) pixel (width by height) character matrix should be the minimum, or modification of characters should be used.

NOTE 2 Examples for (24 × 24) pixel matrices can be found in JIS X 9052.

If only a limited and predefined set of characters is used, and these characters are clearly discriminable from one another, a smaller pixel matrix may be used.

4.7 Reflections and glare

Reflections and glare visible by the driver should be minimized. Additional reflection-reduction and glare-reduction or contrast-enhancement techniques, if used, shall not cause the display to deviate from the requirements of this document.

4.8 Characteristics of presentation

4.8.1 Image instability

The image should be free from temporal instability (flicker) and spatial instability.

One factor of spatial instability is peak-to-peak variation in the geometric location of the image within the display (jitter): this shall not exceed $0,000 2 \times d$, where d is the viewing distance between the centre of the cyclopean eyellipse and the centre of the display.

NOTE Additional factors contributing to spatial image stability, e.g. display vibrations generated by the vehicle, are not considered in this document.

For displays with pixels having continuous luminance distributions only, jitter can be measured using a measuring microscope with a magnification of at least 20. The movement is determined by visual alignment of the microscope cursor, or comparator reticle, with the extreme positions of the centroid, or the edge of a character, or test object, during the observation period.

For any display type, a special display-measuring device may be used. This device shall be used to determine, on a scan-by-scan basis, the relative location of a character or test object. If the device used determines movement along the horizontal and vertical axes separately, the extent of the jitter shall be defined as the square root of the sum of the squares of the maximum horizontal and vertical differences.

Observations shall continue for at least 4 s.

4.8.2 Image flashing

Image flashing should be used only to attract attention and inform about critical conditions requiring an immediate action. In order to attract attention, a flash frequency of 1 Hz to 5 Hz with a duty cycle of 50 % to 70 % should be used.

The flashing rate should be measured using a luminance meter aimed at the flashing picture element (i.e. a pixel or segment) located in the display centre. The meter should be capable of delivering the time varying luminance values with a low-pass cut-off frequency of at least 10 times the highest frequency to be measured. The signal should be processed with an oscilloscope or similar instrument with adequate bandpass in order to obtain the “ON” and “OFF” durations.

In order to measure the “ON” and “OFF” durations (points 1 and 2 in [Figure 13](#)), the switching times (points 3, 4 and 5 in [Figure 13](#)) are established at which the luminance is equal to the average luminance between the minimum and the maximum luminance values (L_{low} and L_{high} in [Figure 13](#)). The “ON” duration is the time between points 3 and 4, and the “OFF” duration is the time between points 4 and 5.

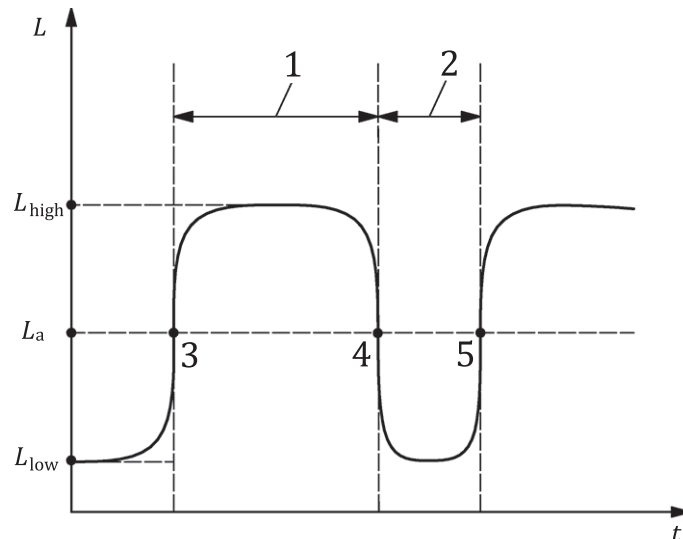

Key

- | | | | |
|---|---------------------|------------|-------------------|
| 1 | “ON” duration | L | luminance |
| 2 | “OFF” duration | L_a | average luminance |
| 3 | switch-on time | L_{high} | maximum luminance |
| 4 | switch-off time | L_{low} | minimum luminance |
| 5 | next switch-on time | t | time |

Figure 13 — Flashing frequency measurement

The equivalent frequency (in hertz) should be obtained from the duration (in seconds). For pulse width modulated backlight, the effect of the backlight variation should be considered (e.g. triggering of oscilloscope). Alternatively, a continuous stable backlight should be used for these measurements.

4.9 Redundant information displays

If the same information is presented in more than one display, at least one of the information displays shall meet the requirements of this document. Other redundant information displays may also meet the requirements of this document.

Annex A (normative)

Definition and measurement of character dimensions

A.1 Character dimensions

All the character dimensions are measured in angular values as the subtended angle of the feature (e.g. height or width), as seen from the specified viewing point.

The angular values, expressed in radians, are derived from the linear values, in [Formula \(A.1\)](#):

$$\alpha_R = \frac{x}{d} \quad (\text{A.1})$$

where

α_R is the angular dimension, in radians;

x is the linear dimension of the character (e.g. height or width), projected on a plane perpendicular to the viewing direction;

d is the viewing distance from the back centroid of the cyclopean eyellipse.

Both x and d shall be expressed in homogeneous units (e.g. millimetres).

The angular dimension, α_A , expressed in arc minutes (1 arcmin = 1°/60) is derived from the dimensions, in radians, in [Formula \(A.2\)](#):

$$\alpha_A = 60 \left(\frac{180 \times \alpha_R}{\pi} \right) \quad (\text{A.2})$$

For practical use, [Formula \(A.2\)](#) can be written as follows:

$$\alpha_A = \frac{3\,438 \times x}{d}$$

The character dimensions shall be as defined in [Figure A.1](#), using characters “H” and “A”. If both normal and bold fonts are available, the character dimensions are taken from the normal font.

A.2 Character size measurement

Character height of a particular character font shall be measured as the distance between the base line and the cap line of this font, as shown in [Figure A.1](#). The character “H” should be used to define the character height.

Character width of a particular character font shall be measured as the distance between appropriate parallel edges of the character “H”, as shown in [Figure A.1](#).

For the purposes of the dimensional, not optical, measurement, the character edge is defined as extending to the point of 50 % luminance difference between the character and the background. The 50 % point is determined from measurement of the character luminance profile. The measurement equipment shall be capable of reliably measuring the smallest uniform area of the character.

The dimensions of the characters may also be determined by calculation based on the dimension of the character font, the display specification, and the anti-aliasing specification.



Figure A.1 — Character dimensions

Annex B (informative)

Colour combinations

[Table B.1](#) provides guidance on combinations of symbol colour and background colour.

Table B.1 — Symbol/background colour combinations

Background colour	Symbol colour						
	White	Yellow	Orange	Red ^a , Purple	Green, Cyan	Blue ^a , Violet	Black
White		–	o	+	+	++	++
Yellow	–		–	o	o	+	++
Orange	o	–		–	–	o	+
Red ^a , Purple	+	o	–		–	–	+
Green, Cyan	+	o	–	–		–	+
Blue ^a , Violet	++	+	o	–	–		–
Black	++	++	+	+	+	–	
++ Preferred + Recommended o Acceptable with high saturation differences – Not recommended							
^a Pure red and blue should be avoided in view of the fact that the eyes may have trouble focusing on these colours because of eye chromatic aberration.							

More precise information is available in Reference [\[17\]](#), which contains several sections on luminance and colour contrast.

Annex C (informative)

Terminology of typographic terms and visual dictionary

C.1 Terminology

[Figure C.1](#) shows a terminology example.

x-height	height of lower case x
cap height	height of capitals such as H
x:H	ratio of x-height to cap height
lm space	space between two vertical strokes such as l and m
vl space	space between diagonal characters such as v and l
stem width	width of vertical strokes such as l
even spacing	spacing of text that has a uniform rhythm
proportional spacing	spacing of text that varies according to letter dimensions; opposite of mono-spacing
l-proportion	ratio of stem width to ascender height (the width of the vertical stroke of lower case L divided by its height)

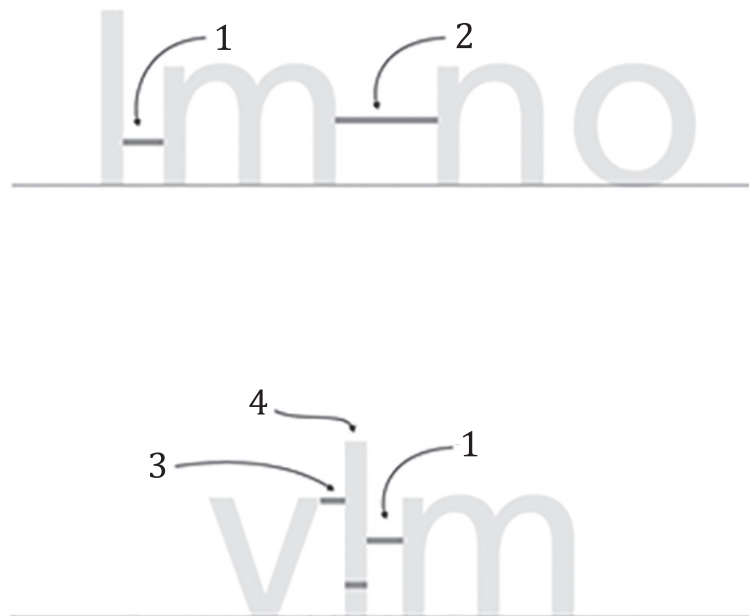

Key

- 1 lm space
- 2 space
- 3 vl space
- 4 stem width

Figure C.1 — Terminology example

C.2 Why the x-height and H-proportion are important

Two typefaces can have the same capital height but vary tremendously in how big they appear to be because the actual perceived size is usually dependent on how high the x-height is and how wide the proportions are.

C.3 Visual dictionary

[Figure C.2](#) and [Figure C.3](#) show example of popular typefaces at default settings. These show conventional proportions that can be found in many other designs.

Take exit	v-l: 97%	l-m: 155%	x:H: 72%
Take exit	v-l: 110%	l-m: 182%	x:H: 68%
Take exit	v-l: 86%	l-m: 150%	x:H: 71%
Take exit	v-l: 91%	l-m: 181%	x:H: 69%
Take exit	v-l: 89%	l-m: 161%	x:H: 71%
Take exit	v-l: 103%	l-m: 203%	x:H: 73%
Take exit	v-l: 125%	l-m: 230%	x:H: 70%
Take exit	v-l: 116%	l-m: 197%	x:H: 62%

Figure C.2 — Example of popular typefaces at default settings

Take exit	H-proportion : 79%	l-proportion: 12%
Take exit	H-proportion : 76%	l-proportion: 13%
Take exit	H-proportion : 80%	l-proportion: 13%
Take exit	H-proportion : 65%	l-proportion: 13%
Take exit	H-proportion : 80%	l-proportion: 14%
Take exit	H-proportion : 68%	l-proportion: 13%
Take exit	H-proportion : 71%	l-proportion: 12%
Take exit	H-proportion : 77%	l-proportion: 10%

Figure C.3 — Example of popular typefaces at default settings

C.4 Example of proportional vs. mono-spaced typefaces at default settings

Figure C.4 shows an example for a mono-spaced typeface where all letters have the same width.

Scientists have used a 3D-printed model of shark skin to show how tooth-like scales help the predators to cruise efficiently. Viewed up close, a shark's skin bristles

abconilvw

Scientists have used a 3D-printed model of shark skin to show how tooth-like scales help the predators to cruise efficiently. Viewed up close, a shark's skin bristles with tiny teeth or "denticles" which aid

abconilvw

Figure C.4 — Example for a mono-spaced typeface where all letters have the same width

C.5 Example of weights and proportions that are within acceptable limits

Figure C.5 shows an example of weights and proportions that are within acceptable limits.

Take exit
Take exit
Take exit

Take exit
Take exit
Take exit

Take exit
Take exit
Take exit

Take exit
Take exit

Take exit

Take exit

Take exit — OK

Take exit — OK

Figure C.5 — Example of weights and proportions that are within acceptable limits

Bibliography

- [1] ISO 2575, *Road vehicles — Symbols for controls, indicators and tell-tales*
- [2] ISO 3833, *Road vehicles — Types — Terms and definitions*
- [3] ISO 13406 (all parts)¹⁾, *Ergonomic requirements for work with visual displays based on flat panels*
- [4] JIS X 9051, 16-dots matrix character patterns for display devices
- [5] JIS X 9052, 24-dots matrix character patterns for dot printers
- [6] BOFF K.R., & LINCOLN J.E. *Engineering Data Compendium: Human Perception and Performance*. AAMRL, Wright-Patterson AFB, OH, USA, 1988
- [7] IMBEAU D., WIERWILLE W.W., BEAUCHAMP Y. *Age, display design and driving performance*. Peacock and Karwowski, 1993, pp. 339.
- [8] MOURANT R.R., & LANGOLF G.D. Luminance specifications for automobile instrument panels. *Hum. Factors*. 1976, **18** pp. 71–84
- [9] PEACOCK B., & KARWOWSKI W. *Automotive Ergonomics*. Taylor and Francis, 1993
- [10] SMITH S.L. Letter Size and Legibility. *Hum. Factors*. 1979, **21** pp. 661–670
- [11] WIDDEL H., & POST D.L. eds. *Colour in Electronic Displays*. Plenum Press, New York, 1992
- [12] BHISE V.D., & HAMMOUDEH R.W. A PC Based Model for Prediction of Visibility and Legibility for a Human Factors Engineer's Tool Box, Proceedings of the Human Factors and Ergonomics Society 48th Annual Meeting in New Orleans, Louisiana, September 2004
- [13] GREEN P., GOLDSTEIN S., ZELTNER K., ADAMS S. (1988). Legibility of Text on Instrument Panels: A Literature Review (Technical Report UMTRI-88-34). Ann Arbor, MI: The University of Michigan Transportation Research Institute. (NTIS No. PB 90 141342/AS)
- [14] WHITTLE P. The Psychophysics of Contrast Brightness. In: *Lightness, Brightness, and Transparency*, (GILCHRIST A.L. ed.). Lawrence Erlbaum Associates, Hillsdale, NJ, 1994, pp. 35–110.
- [15] BOYCE P.R. *Human Factors in Lighting Publication CRC Press*. Boca Raton, USA, 2014
- [16] CIE S 017/E:2011 ILV: International Lighting Vocabulary. Vocabulary terms are defined online at <http://eilv.cie.co.at/>
- [17] CAMPBELL J.L., CARNEY C., KANTOWITZ B.H. *Human Factors Design Guidelines for Advanced Traveler Information Systems (ATIS) and Commercial Vehicle Operations (CVO)*. FHWA-RD-98-057. Available at: <http://www.fhwa.dot.gov/publications/research/safety/98057/ch03a.cfm#colorcntst>

1) Withdrawn. Replaced by ISO 9241-302:2008.

British Standards Institution (BSI)

BSI is the national body responsible for preparing British Standards and other standards-related publications, information and services.

BSI is incorporated by Royal Charter. British Standards and other standardization products are published by BSI Standards Limited.

About us

We bring together business, industry, government, consumers, innovators and others to shape their combined experience and expertise into standards-based solutions.

The knowledge embodied in our standards has been carefully assembled in a dependable format and refined through our open consultation process. Organizations of all sizes and across all sectors choose standards to help them achieve their goals.

Information on standards

We can provide you with the knowledge that your organization needs to succeed. Find out more about British Standards by visiting our website at bsigroup.com/standards or contacting our Customer Services team or Knowledge Centre.

Buying standards

You can buy and download PDF versions of BSI publications, including British and adopted European and international standards, through our website at bsigroup.com/shop, where hard copies can also be purchased.

If you need international and foreign standards from other Standards Development Organizations, hard copies can be ordered from our Customer Services team.

Copyright in BSI publications

All the content in BSI publications, including British Standards, is the property of and copyrighted by BSI or some person or entity that owns copyright in the information used (such as the international standardization bodies) and has formally licensed such information to BSI for commercial publication and use.

Save for the provisions below, you may not transfer, share or disseminate any portion of the standard to any other person. You may not adapt, distribute, commercially exploit, or publicly display the standard or any portion thereof in any manner whatsoever without BSI's prior written consent.

Storing and using standards

Standards purchased in soft copy format:

- A British Standard purchased in soft copy format is licensed to a sole named user for personal or internal company use only.
- The standard may be stored on more than 1 device provided that it is accessible by the sole named user only and that only 1 copy is accessed at any one time.
- A single paper copy may be printed for personal or internal company use only.

Standards purchased in hard copy format:

- A British Standard purchased in hard copy format is for personal or internal company use only.
- It may not be further reproduced – in any format – to create an additional copy. This includes scanning of the document.

If you need more than 1 copy of the document, or if you wish to share the document on an internal network, you can save money by choosing a subscription product (see 'Subscriptions').

Reproducing extracts

For permission to reproduce content from BSI publications contact the BSI Copyright & Licensing team.

Subscriptions

Our range of subscription services are designed to make using standards easier for you. For further information on our subscription products go to bsigroup.com/subscriptions.

With **British Standards Online (BSOL)** you'll have instant access to over 55,000 British and adopted European and international standards from your desktop. It's available 24/7 and is refreshed daily so you'll always be up to date.

You can keep in touch with standards developments and receive substantial discounts on the purchase price of standards, both in single copy and subscription format, by becoming a **BSI Subscribing Member**.

PLUS is an updating service exclusive to BSI Subscribing Members. You will automatically receive the latest hard copy of your standards when they're revised or replaced.

To find out more about becoming a BSI Subscribing Member and the benefits of membership, please visit bsigroup.com/shop.

With a **Multi-User Network Licence (MUNL)** you are able to host standards publications on your intranet. Licences can cover as few or as many users as you wish. With updates supplied as soon as they're available, you can be sure your documentation is current. For further information, email subscriptions@bsigroup.com.

Revisions

Our British Standards and other publications are updated by amendment or revision.

We continually improve the quality of our products and services to benefit your business. If you find an inaccuracy or ambiguity within a British Standard or other BSI publication please inform the Knowledge Centre.

Useful Contacts

Customer Services

Tel: +44 345 086 9001

Email (orders): orders@bsigroup.com

Email (enquiries): cservices@bsigroup.com

Subscriptions

Tel: +44 345 086 9001

Email: subscriptions@bsigroup.com

Knowledge Centre

Tel: +44 20 8996 7004

Email: knowledgecentre@bsigroup.com

Copyright & Licensing

Tel: +44 20 8996 7070

Email: copyright@bsigroup.com

BSI Group Headquarters

389 Chiswick High Road London W4 4AL UK