

**Petroleum,  
petrochemical and  
natural gas industries  
— Flexible couplings  
for mechanical power  
transmission —  
General-purpose  
applications (ISO  
14691:2008)**

ICS 75.180.20

## National foreword

This British Standard is the UK implementation of EN ISO 14691:2008. It supersedes BS EN ISO 14691:2000 which is withdrawn.

The UK participation in its preparation was entrusted to Technical Committee PSE/17/-/6, Materials and equipment for petroleum, petrochemical and natural gas industries.

A list of organizations represented on this committee can be obtained on request to its secretary.

This publication does not purport to include all the necessary provisions of a contract. Users are responsible for its correct application.

**Compliance with a British Standard cannot confer immunity from legal obligations.**

This British Standard was published under the authority of the Standards Policy and Strategy Committee on 28 February 2009

© BSI 2009

ISBN 978 0 580 58659 0

### Amendments/corrigenda issued since publication

Date	Comments

EUROPEAN STANDARD

EN ISO 14691

NORME EUROPÉENNE

EUROPÄISCHE NORM

December 2008

ICS 75.180.20

Supersedes EN ISO 14691:2000

English Version

Petroleum, petrochemical and natural gas industries - Flexible couplings for mechanical power transmission - General-purpose applications (ISO 14691:2008)

Industries du pétrole, de la pétrochimie et du gaz naturel -  
Accouplements flexibles pour transmission de puissance  
mécanique - Applications d'usage général (ISO  
14691:2008)

Erdöl-, petrochemische und Erdgasindustrie - Flexible  
Kupplungen für mechanische Kraftübertragung -  
Allgemeine Anwendungsfälle (ISO 14691:2008)

This European Standard was approved by CEN on 28 November 2008.

CEN members are bound to comply with the CEN/CENELEC Internal Regulations which stipulate the conditions for giving this European Standard the status of a national standard without any alteration. Up-to-date lists and bibliographical references concerning such national standards may be obtained on application to the CEN Management Centre or to any CEN member.

This European Standard exists in three official versions (English, French, German). A version in any other language made by translation under the responsibility of a CEN member into its own language and notified to the CEN Management Centre has the same status as the official versions.

CEN members are the national standards bodies of Austria, Belgium, Bulgaria, Cyprus, Czech Republic, Denmark, Estonia, Finland, France, Germany, Greece, Hungary, Iceland, Ireland, Italy, Latvia, Lithuania, Luxembourg, Malta, Netherlands, Norway, Poland, Portugal, Romania, Slovakia, Slovenia, Spain, Sweden, Switzerland and United Kingdom.



EUROPEAN COMMITTEE FOR STANDARDIZATION  
COMITÉ EUROPÉEN DE NORMALISATION  
EUROPÄISCHES KOMITEE FÜR NORMUNG

Management Centre: rue de Stassart, 36 B-1050 Brussels

## Foreword

This document (EN ISO 14691:2008) has been prepared by Technical Committee ISO/TC 67 "Materials, equipment and offshore structures for petroleum and natural gas industries" in collaboration with Technical Committee CEN/TC 12 "Materials, equipment and offshore structures for petroleum, petrochemical and natural gas industries", the secretariat of which is held by AFNOR.

This European Standard shall be given the status of a national standard, either by publication of an identical text or by endorsement, at the latest by June 2009, and conflicting national standards shall be withdrawn at the latest by June 2009.

Attention is drawn to the possibility that some of the elements of this document may be the subject of patent rights. CEN [and/or CENELEC] shall not be held responsible for identifying any or all such patent rights.

This document supersedes EN ISO 14691:2000.

According to the CEN/CENELEC Internal Regulations, the national standards organizations of the following countries are bound to implement this European Standard: Austria, Belgium, Bulgaria, Cyprus, Czech Republic, Denmark, Estonia, Finland, France, Germany, Greece, Hungary, Iceland, Ireland, Italy, Latvia, Lithuania, Luxembourg, Malta, Netherlands, Norway, Poland, Portugal, Romania, Slovakia, Slovenia, Spain, Sweden, Switzerland and the United Kingdom.

### Endorsement notice

The text of ISO 14691:2008 has been approved by CEN as a EN ISO 14691:2008 without any modification.

# Contents

Page

Foreword.....	iv
Introduction .....	v
<b>1 Scope .....</b>	<b>1</b>
<b>2 Normative references .....</b>	<b>1</b>
<b>3 Terms and definitions.....</b>	<b>2</b>
<b>4 Statutory requirements .....</b>	<b>5</b>
<b>5 Coupling selection.....</b>	<b>5</b>
5.1 General.....	5
5.2 Compliance.....	6
<b>6 Purchaser's specification .....</b>	<b>6</b>
<b>7 Coupling rating .....</b>	<b>8</b>
<b>8 Construction requirements.....</b>	<b>9</b>
8.1 General.....	9
8.2 Materials of construction .....	10
8.3 Coupling hubs.....	11
8.4 Bolting.....	12
8.5 Electrical insulation .....	12
8.6 Alignment provision .....	12
8.7 Rotor dynamic data .....	12
8.8 Non-horizontal applications .....	13
8.9 Additional requirements for gear couplings.....	13
8.10 Additional requirements for metallic flexible-element couplings.....	13
8.11 Additional requirements for elastomeric couplings .....	13
<b>9 Balance .....</b>	<b>14</b>
9.1 Objectives.....	14
9.2 Balance quality.....	14
9.3 Additional balancing requirements.....	15
9.4 Verification of coupling balance .....	15
<b>10 Accessories.....</b>	<b>15</b>
<b>11 Manufacturing quality, inspection, testing and preparation for shipment .....</b>	<b>15</b>
11.1 Manufacturing quality.....	15
11.2 Inspection and testing.....	16
11.3 Preparation for shipment .....	16
<b>12 Vendor's data .....</b>	<b>16</b>
12.1 General.....	16
12.2 Proposals.....	16
12.3 Contract data.....	17
<b>Annex A (informative) Examples of misalignment.....</b>	<b>19</b>
<b>Annex B (informative) Example of the determination of potential unbalance .....</b>	<b>21</b>
<b>Annex C (informative) Coupling tapers.....</b>	<b>24</b>
<b>Annex D (normative) Coupling guards .....</b>	<b>25</b>
<b>Annex E (informative) Coupling datasheets.....</b>	<b>27</b>
<b>Bibliography .....</b>	<b>32</b>

## Foreword

ISO (the International Organization for Standardization) is a worldwide federation of national standards bodies (ISO member bodies). The work of preparing International Standards is normally carried out through ISO technical committees. Each member body interested in a subject for which a technical committee has been established has the right to be represented on that committee. International organizations, governmental and non-governmental, in liaison with ISO, also take part in the work. ISO collaborates closely with the International Electrotechnical Commission (IEC) on all matters of electrotechnical standardization.

International Standards are drafted in accordance with the rules given in the ISO/IEC Directives, Part 2.

The main task of technical committees is to prepare International Standards. Draft International Standards adopted by the technical committees are circulated to the member bodies for voting. Publication as an International Standard requires approval by at least 75 % of the member bodies casting a vote.

Attention is drawn to the possibility that some of the elements of this document may be the subject of patent rights. ISO shall not be held responsible for identifying any or all such patent rights.

ISO 14691 was prepared by Technical Committee ISO/TC 67, *Materials, equipment and offshore structures for petroleum, petrochemical and natural gas industries*, Subcommittee SC 6, *Processing equipment and systems*.

This second edition cancels and replaces the first edition (ISO 14691:1999), which has been technically revised.

## Introduction

Users of this International Standard should be aware that further or differing requirements may be needed for individual applications. This International Standard is not intended to inhibit a vendor from offering, or the purchaser from accepting, alternative equipment or engineering solutions for the individual application. This may be particularly appropriate where there is innovative or developing technology. Where an alternative is offered, the vendor should identify any variations from this International Standard and provide details.

For the following applications, the use of ISO 10441 is recommended:

- large or high-speed machines that may be required to operate continuously for extended periods, are often unspared and are critical to the continued operation of the installation (special-purpose applications);
- machines in which the first lateral critical speed is less than the maximum required operating speed (flexible-shaft machines);
- machines in which the rotor dynamics are particularly sensitive to coupling unbalance.

This International Standard requires the purchaser to specify certain details and features. A bullet (●) at the beginning of a subclause or paragraph indicates that either a decision is required or that further information is to be provided by the purchaser. This information should be indicated on the datasheet(s), typical examples of which are included as Annex E, otherwise it should be stated in the quotation request or in the order.

The coupling vendor is not normally required to supply the coupling guard or guards. However, for completeness and for the information of the user of this International Standard, Annex D, which provides requirements for guards, has been added.





# Petroleum, petrochemical and natural gas industries — Flexible couplings for mechanical power transmission — General-purpose applications

## 1 Scope

This International Standard specifies the requirements for couplings for the transmission of power between the rotating shafts of two machines for general-purpose applications in the petroleum, petrochemical and natural gas industries. Such applications typically require couplings to transmit power at speeds not exceeding 4 000 r/min, between machines in which the first lateral critical speed is above the running speed range (stiff-shaft machines). It can, by agreement, be used for applications outside these limits.

NOTE 1 Recommendations are included in the Introduction as to when the use of ISO 10441 should be considered.

This International Standard is applicable to couplings designed to accommodate parallel (or lateral) offset, angular misalignment and axial displacement of the shafts without imposing excessive mechanical loading on the coupled machines. Couplings covered by this International Standard include gear (and other mechanical contact types), metallic flexible-element and various elastomeric types. Such couplings can be of all metal construction or can include components of non-metallic materials, such as composites.

This International Standard covers design, materials of construction, inspection and testing of couplings and methods of attachment of the coupling to the shafts (including tapered sleeve and other proprietary devices).

This International Standard does not apply to special types of couplings, such as clutch, hydraulic, eddy-current, rigid and radial-spline types.

This International Standard does not define criteria for the selection of coupling types for specific applications.

NOTE 2 In many cases, couplings covered by this International Standard are manufacturers' catalogue items.

## 2 Normative references

The following referenced documents are indispensable for the application of this document. For dated references, only the edition cited applies. For undated references, the latest edition of the referenced document (including any amendments) applies.

ISO 286-2:1988, *ISO system of limits and fits — Part 2: Tables of standard tolerance grades and limit deviations for holes and shafts*

ISO 1940-1:2003, *Mechanical vibration — Balance quality requirements for rotors in a constant (rigid) state — Part 1: Specification and verification of balance tolerances*

ISO 8821, *Mechanical vibration — Balancing — Shaft and fitment key convention*

ANSI/AGMA 9002, *Bores and Keyways for Flexible Couplings (Inch Series)*

ANSI/AGMA 9003, *Flexible Couplings — Keyless Fits*

ANSI/AGMA 9112, *Bores and Keyways for Flexible Couplings (Metric Series)*

DIN 7190, *Interference fits — Calculation and design rules*<sup>1)</sup>

### 3 Terms and definitions

For the purposes of this document, the following terms and definitions apply.

**3.1**  
**angular misalignment**  
<double-engagement couplings> two minor angles between the extension of each machine shaft centre-line and the centre-line of the structure joining the two flexible elements

**3.2**  
**angular misalignment**  
<single-engagement couplings> minor angle between the extensions of the shaft centre-lines of the two coupled machines

**3.3**  
**axial displacement**  
change in the relative axial position of the adjacent shaft ends of two coupled machines, usually caused by thermal expansion

**3.4**  
**continuous torque rating**  
coupling manufacturer's declared maximum torque that the coupling can transmit continuously for the specified life

**3.5**  
**distance between shaft ends**  
**DBSE**  
distance from the extreme end of one shaft (including any threaded end) to the extreme end of the next shaft or, in the case of integral flanges, the distance from the mating faces

**3.6**  
**double-engagement coupling**  
coupling with two planes of flexure

NOTE This arrangement enables couplings of certain types, notably gear and metallic flexible-element types, that cannot normally accommodate parallel (or lateral) offset, to do so.

**3.7**  
**gear coupling**  
coupling of the mechanical contact type that transmits torque and accommodates misalignment and axial displacement by relative rocking and sliding motion between mating, profiled gear teeth

**3.8**  
**lateral offset**  
lateral distance between the centre-lines of two shafts that are not parallel, measured perpendicularly to the centre-line and in the plane of the shaft end of the driving machine

See Annex A.

**3.9**  
**manufacturer**  
agency responsible for the design and fabrication of the coupling

NOTE The manufacturer is not necessarily the vendor.

1) Deutsches Institut für Normung, Burggrafenstraße 6, Berlin, Germany D-10787.

### 3.10

#### **maximum allowable speed**

maximum speed for which the manufacturer has designed the coupling

### 3.11

#### **maximum allowable temperature**

maximum continuous temperature for which the manufacturer has designed the coupling

### 3.12

#### **maximum continuous angular misalignment**

maximum angular misalignment at each plane of flexure that the coupling is able to tolerate for the specified life (5.1.3) when transmitting the coupling continuous torque rating at the coupling rated speed, and when simultaneously subjected to the coupling maximum continuous axial displacement

### 3.13

#### **maximum continuous axial displacement**

maximum axial displacement the coupling is able to tolerate for the specified life (5.1.3) when transmitting the coupling continuous torque rating at the coupling rated speed and when simultaneously subjected to the coupling maximum continuous angular misalignment

### 3.14

#### **maximum continuous speed**

highest rotational speed at which the coupling, as made and tested, is capable of continuous operation

### 3.15

#### **mechanical contact coupling**

coupling designed to transmit torque by direct mechanical contact between mating parts and accommodate misalignment and axial displacement by relative rocking and sliding motion between the parts in contact

NOTE 1 Examples of mechanical contact couplings are gear, grid, and pin-bushing couplings.

NOTE 2 The contacting parts can be metallic or can be made of self-lubricating non-metallic material.

NOTE 3 These couplings do not have a free-state position but resist change in the axial and angular direction, mainly as a function of transmitted torque and the coefficient of friction between the contacting parts.

### 3.16

#### **metallic flexible-element coupling**

coupling that obtains its flexibility from the flexing of thin metallic discs, diaphragms or links

### 3.17

#### **momentary torque limit**

maximum instantaneous torque that the coupling can tolerate without suffering immediate failure

### 3.18

#### **owner**

final recipient of the equipment who may delegate another agent as the purchaser of the equipment

### 3.19

#### **parallel offset**

distance between the centre-lines of two coupled shafts that are parallel but not in the same straight line

See Annex A.

### 3.20

#### **peak torque rating**

maximum torque the coupling can tolerate for short periods

**3.21**  
**pilot**  
**rabbet**  
**register**  
**spigot**

surface that positions a coupling component, sub-assembly, or assembly radially with respect to another coupling component

**3.22**  
**potential unbalance**

probable net unbalance of a complete coupling

NOTE 1 Potential unbalance results from a combination of the residual unbalance of individual components and sub-assemblies and possible eccentricity of the components and sub-assemblies due to run-out and tolerances of the various surfaces and registers. Since it can be assumed that the actual values of the various contributory unbalances are random in both magnitude and direction, the numerical value of the potential unbalance is the square root of the sum of the squares of all the contributory unbalances. Typical contributory unbalances are

- a) the residual unbalance of each component or sub-assembly,
- b) errors in the balance of each component or sub-assembly resulting from eccentricity in the fixture used to mount the component or sub-assembly in the balance machine,
- c) the unbalance of each component or sub-assembly due to eccentricity resulting from clearance or run-out of the relevant registers or fits.

NOTE 2 The concept of potential unbalance is explained more fully, and a worked example is provided, in Annex B.

**3.23**  
**purchaser**

agency that issues the order and the specification to the vendor

NOTE The purchaser can be the owner of the plant in which the equipment is being installed, the owner's appointed agent or, frequently, the manufacturer of the driven machine.

**3.24**  
**rated speed**

highest rotational speed at which the coupling is required to be capable of transmitting the continuous torque rating while simultaneously subjected to the coupling rated axial displacement and the rated angular misalignment (or the rated parallel or lateral offset in the case of a single-engagement coupling)

**3.25**  
**residual unbalance**

level of unbalance remaining in a component or assembly after it has been balanced, either to the limit of the capability of the balancing machine or in accordance with the relevant standard

**3.26**  
**service factor**

factor applied to the steady-state torque in order to allow for off-design conditions, cyclic and other variations as well as equipment variations resulting in a torque higher than that at the equipment normal operating point

**3.27**  
**single-engagement coupling**

coupling with only one plane of flexure

NOTE This type of coupling can accommodate angular misalignment and axial displacement. Single-engagement couplings of some types, notably gear and metallic flexible-element types, do not normally accommodate parallel (or lateral) offset. Certain types of single-engagement couplings can accommodate offset misalignment to a limited extent.

**3.28**  
**spacer**

part of a coupling that is removable to give access for maintenance and/or removal of the coupling hubs

NOTE The spacer can be a single component or an assembly.

### 3.29

#### **spacer gap length**

distance between coupling hubs or sleeves in which the coupling spacer is installed

NOTE Spacer gap length is not necessarily equal to the distance between the shaft ends.

### 3.30

#### **torsional stiffness**

rate of change of the angular deflection with respect to the applied torque about the axis of rotation

NOTE With some types of couplings, the torsional stiffness is not constant but is a function of the magnitude of the torque and, with oscillating torques, also the frequency.

### 3.31

#### **trip speed**

rotational speed at which the independent emergency overspeed device operates to shut down a variable-speed prime mover or, for the purposes of this International Standard, in the case of alternating current electric motors, the speed corresponding to the synchronous speed of the motor at line frequency or, in the case of variable-frequency drives, at maximum supply frequency

### 3.32

#### **unit responsibility**

responsibility for co-ordinating the delivery and technical aspects of the equipment and all auxiliary systems included in the scope of the order

NOTE The technical aspects for consideration include, but are not limited to, such factors as the power requirements, speed, rotation, general arrangement, dynamics, noise, lubrication, sealing system, material test reports, instrumentation, piping, conformance to specifications and testing of components.

### 3.33

#### **vendor supplier**

agency that supplies the equipment

NOTE The vendor is the manufacturer of the equipment or the manufacturer's agent and normally is responsible for service support.

## 4 Statutory requirements

The purchaser and the vendor shall mutually determine the measures taken to comply with any federal, state or local codes, regulations, ordinances or rules that are applicable to the equipment.

## 5 Coupling selection

### 5.1 General

5.1.1 The coupling type, size and rating supplied in accordance with this International Standard may be selected by one of the following methods.

- Method A: The coupling is selected by the purchaser from the manufacturer's catalogue.
- Method B: The coupling is selected by the purchaser from the manufacturer's catalogue and the selection is agreed and approved by the vendor based on data supplied by the purchaser.
- Method C: The coupling is recommended by the vendor based on data supplied by the purchaser.

**5.1.2** In the case of method A, before accepting an order, the vendor shall advise the purchaser if, based on the information he has, he believes the coupling selected is not suitable for the application.

**5.1.3** Unless otherwise agreed, couplings shall be designed, constructed and selected for a life of not less than 5 years' continuous operation transmitting the continuous torque rating, at the rated speed and subjected to the maximum continuous misalignment and axial displacement.

NOTE This requirement relates to the design of the coupling and does not imply a guaranteed life.

● If specified, the vendor shall provide evidence to demonstrate that this required life can be expected to be achieved. This may be by providing details for the purchaser's inspection of one of the following:

- at least three similar couplings in similar applications that have achieved a satisfactory life of at least 5 years in continuous service;
- extended laboratory tests on similar complete couplings or on the highly stressed components;
- fatigue analysis of the flexible elements and other highly stressed components where these are of a form that is capable of precise stress analysis.

## 5.2 Compliance

**5.2.1** To facilitate selection in methods A and B, the vendor's catalogue should clearly state that the couplings described fully comply with the requirements of this International Standard or should clearly identify the extent to which any particular type or model does not comply.

**5.2.2** Where the necessary information is not included in the vendor's catalogue, and for selection method C, the vendor shall state that the offered/recommended coupling complies with the requirements of this International Standard or shall clearly identify the extent to which it does not comply.

## 6 Purchaser's specification

**6.1** It is recommended that the information the purchaser is required to provide be specified by being entered on a suitable data sheet, a typical form of which is given in Annex E. Where appropriate, the information required should be provided in the form of sketches or diagrams.

● **6.2** If the purchaser makes his own selection from the vendor's catalogue, he should specify the type, model and size of coupling required taking into account a suitable value for the service factor,  $K_s$ , and the required misalignment and axial deflection capability.

The value of the service factor,  $K_s$ , should be selected to allow for torque variations due to the type of driving and driven machines and possible future changes in the duty and should not generally be less than the values in Table 1.

**Table 1 — Service factors for electric motor and turbine prime movers**

Driven machine	$K_s$
Generator	1,2
Dynamic (centrifugal or axial) pump or compressor	1,25
Fan or rotary displacement pump or compressor	1,5
Reciprocating pump or compressor with four or more cylinders	1,75
Reciprocating pump or compressor with fewer than four cylinders	2,5

- **6.3** If the coupling vendor is required to recommend a coupling (selection method C) or approve the purchaser's selection (selection method B), the purchaser shall provide the following information:
  - a) make and type of driving and driven machine, and a description of the whole machine train if this is comprised of more than two coupled units;
  - b) type of coupling (gear, flexible element, etc.) required and the method of attachment to the shafts;
  - c) rated speed (3.24), the equipment's operating speed range and the trip speed (3.31);

NOTE The rated speed is normally the maximum continuous speed.

- d) maximum torque,  $T_m$ , that it is required to transmit;

NOTE The required continuous torque rating is not less than the maximum continuous torque that it is required to transmit under any operating condition. Where one single machine is driven from a driver, the maximum continuous torque is generally the maximum continuous torque of the driver. Where two or more machines are driven from one driver, either in tandem through a multi-shaft gearbox or from both ends of the driver, the maximum continuous torque for each coupling is generally based on the most adverse possible split of power consumption between the driven machines.

- e) value used for the service factor,  $K_s$ , as defined in 3.26;
- f) required misalignment capability, in terms of the angular misalignment and the parallel or lateral offset, and the axial displacement that the coupling is required to accommodate;
- g) expected magnitude, nature and number of occurrences of torsional transients that the coupling is required to tolerate in service, without damage;

NOTE Torsional transients include start-up and shut-down effects, particularly those associated with synchronous motors and variable-frequency drive systems.

- h) environment in which the coupling is required to operate, including the maximum and minimum temperatures and the presence of atmospheric contaminants likely to attack the components of the coupling.

- **6.4** The purchaser may specify the axial distance between the extreme ends of the shafts of the two machines being coupled, in the cold static condition. Alternatively, the purchaser may accept the vendor's standard or proposed coupling length.
- **6.5** If relevant, the purchaser should also specify the expected magnitude of momentary torques, resulting from fault conditions, which the coupling is required to survive but possibly with some damage. In particular, in the case of a generator drive, the purchaser should specify the short-circuit torque.

NOTE It is accepted that, after such an event, the coupling will be need to be inspected and components replaced as necessary.

- **6.6** The purchaser may state if any properties of the coupling are considered important from consideration of the rotor dynamics of the driving or driven machines, or for any other reason, and may specify the range of acceptable values. Such properties may, for example, include
  - overhung mass,
  - torsional stiffness,
  - coupling axial reaction force (8.1.4),
  - coupling lateral stiffness, that is, the transverse load on the shafts resulting from unit parallel offset,

— coupling bending stiffness, that is, the bending moment imposed on the shafts resulting from unit angular misalignment.

NOTE It is not expected that this will be necessary for the majority of general-purpose applications.

6.7 The purchaser may indicate a requirement for a coupling design that either maintains or disconnects the drive in the event of failure of the flexing elements.

## 7 Coupling rating

7.1 To facilitate coupling selection methods A and B, the vendor's catalogue shall, for each type, model and size of coupling, clearly indicate

- a) the coupling continuous torque rating,
- b) the maximum continuous angular misalignment at each plane of flexure,
- c) the maximum continuous axial displacement in each direction,
- d) the maximum continuous parallel or lateral offset for single engagement couplings,
- e) the maximum allowable speed,
- f) the maximum continuous speed,
- g) the maximum allowable temperature.

7.2 Where the vendor has been required to propose a coupling (selection method C), the vendor shall provide the data listed in 7.1 for the particular coupling offered in his proposal.

7.3 The coupling continuous torque rating,  $T_c$  (3.4), shall be not less than the value determined by Equation (1):

$$T_c = T_m \times K_s \quad (1)$$

where

$T_m$  is maximum torque that it is necessary to transmit;

$K_s$  is the coupling service factor.

Should the purchaser fail to specify a value for  $K_s$ , the vendor may, for the purpose of initial selection of a coupling, assume a value not less than the appropriate value from Table 1. The vendor shall clearly state his assumed value in his proposal.

7.4 The maximum allowable speed shall not be less than the trip speed.

7.5 The maximum continuous speed of the coupling shall not be less than the rated speed.

7.6 The maximum continuous angular misalignment at each plane of flexure shall be not less than that required [6.3, item f)] or  $0,1^\circ$ , whichever is the greater.

7.7 The maximum continuous axial displacement in either direction from the neutral state, shall be not less than the greatest of

— that required by the purchaser [6.3, item f)];



- 1,5 % of the diameter of the driving or driven machine shaft, whichever is larger;
- 1 mm.

The neutral state of a flexible-element coupling is the cold, unloaded state. The neutral state of a gear or other mechanical contact coupling is the central position.

**7.8** The maximum continuous parallel or lateral offset of a single-engagement coupling shall not be less than the greatest of

- that required by the purchaser [6.3, item f)];
- 0,5 % of the diameter of the driving or driven machine shaft, whichever is larger;
- 0,25 mm.

**7.9** The vendor shall state the relationship between the coupling continuous torque, the coupling continuous misalignment and the coupling continuous axial displacement if the rated maximum values of each cannot be accepted simultaneously.

NOTE 1 With some types of coupling, particularly those with elastomeric elements or inserts, this relationship can also be a function of temperature.

The most severe combination of angular misalignment and lateral offset shall be assumed.

NOTE 2 For double-engagement couplings, the most severe combination normally occurs when the two forms of misalignment are in the same plane and in the same direction (see Figure A.3).

**7.10** The coupling shall be capable of transmitting 115 % of the purchaser-specified maximum transient torque as specified in 6.3, item g), for sufficient duration and frequency to satisfy the operational requirements as specified in 6.3, item g), without damage. If the purchaser has failed to specify the expected transients, the coupling shall be capable of transmitting, without damage, a cyclic torque of amplitude (zero to maximum) equal to twice the maximum torque,  $T_m$ , that it is required to transmit for not less than  $10^3$  cycles.

- **7.11** The coupling shall be strong enough to survive the momentary fault-condition torques specified in accordance with 6.5, albeit with some damage. Alternatively, if specified, the coupling shall incorporate an agreed type of torque-limiting feature to prevent damage to the coupling or to the coupled equipment.

## 8 Construction requirements

### 8.1 General

- **8.1.1** If specified, the coupling design shall be such that the flexible element or elements or inserts, and/or the components carrying the gear teeth or other wearing parts, can be removed and replaced without the requirement to move either the driving or the driven machine or otherwise disturb the alignment.
- **8.1.2** If specified, the design shall be such that the coupling, including hubs, can be completely dismantled and removed to facilitate the maintenance of adjacent bearings and/or seals, without either removing the shaft or disturbing the equipment alignment. The purchaser shall specify the minimum spacer gap length (3.29) required.
- **8.1.3** If specified, the coupling shall be of the limited-end-float design. The purchaser shall specify the end-float required and the maximum axial force the coupling is required to transmit.

NOTE The most common situation in which a limited-end-float coupling is required is with a sleeve-bearing motor without an axial bearing. It is not generally necessary to provide a positive-stop, limited-end-float design with flexible-element couplings, provided that the axial stiffness (spring rate) of the coupling is sufficient to hold the motor rotor within its axial limits during normal operation, start-up and shut-down.

**8.1.4** The vendor shall state the maximum coupling axial reaction force. In the case of gear couplings and other mechanical contact types, this shall be based on the friction between the teeth or other elements under the coupling rated torque; the vendor shall state the assumed value of the friction factor. In the case of flexible-element couplings, the vendor shall provide a curve of axial force versus axial displacement and shall state the maximum acceptable axial displacement.

The coupling axial reaction force is the axial force developed within the coupling resulting from the imposed operating conditions and is a function of the shape and stiffness of the flexible elements or the sliding friction between the elements of a mechanical-contact coupling.

NOTE Examples of imposed operating conditions are axial displacement, misalignment, speed, temperature, etc.

**8.1.5** For double-engagement couplings with a distance between the planes of flexure greater than 50 cm, the vendor shall ensure that either the first lateral resonant frequency of the floating shaft is not less than twice the maximum speed at which the coupling is required to operate (normally the maximum continuous speed), or shall notify the purchaser of the actual value. Details of the method used to determine the first lateral resonant frequency shall be made available for review by the purchaser, if required.

The floating shaft is the component, or assembly of components, of a double-engagement coupling between, and supported from, the two planes of flexure.

**8.1.6** All major parts (hubs, spacers, etc., but excluding flexible elements and fasteners) shall be indelibly marked such that they can be uniquely identified. Marking shall be applied in a low-stress area and shall not affect the performance or integrity of the coupling.

## 8.2 Materials of construction

**8.2.1** Except as required or prohibited by this International Standard or by the purchaser, materials of construction shall be to the vendor's standard for the operating and environmental conditions specified, including the presence of any corrosive agents, particularly any that can cause stress/corrosion cracking.

Where alternative standard materials are offered by the vendor, the purchaser may specify the preferred selection or may leave the selection to the vendor.

**8.2.2** All materials shall be identified by reference to appropriate International Standards. Where no suitable International Standard exists, reference shall be made to internationally recognized national or industry standards. Where no appropriate standard exists, the vendor shall define the requirements of the material in his own standard, including mechanical properties, etc., and shall make such a standard available to the purchaser on request.

**8.2.3** Neither copper nor copper alloys (excluding Monel<sup>2)</sup> or its equivalents, bearing babbitt and precipitation-hardening stainless steels) shall be used for coupling parts, except with the purchaser's approval.

**8.2.4** The flexing elements in metallic flexible-element couplings shall be of corrosion-resistant material or shall have a permanent corrosion-resistant coating.

**8.2.5** Coupling hubs shall be made of materials that are not susceptible to brittle fracture at any specified operating or environmental temperature. Unless otherwise agreed, coupling hubs shall be made of steel or nodular cast iron.

**8.2.6** If non-metallic materials, particularly composite materials, are used for components where the elastic and/or fatigue properties are important (for example long spacers), the vendor shall state the values used for these properties and, if required, shall justify these values by reference to published or experimental data.

---

2) Monel<sup>TM</sup> is an example of a suitable product available commercially. This information is given for the convenience of users of this International Standard and does not constitute an endorsement by ISO of this product.

For the purposes of this International Standard, composite materials are moulded materials of inherently low tensile strength (for example polyester plastic or epoxy resin), which are reinforced by the addition, during the moulding process, of fibres of a stronger material (for example glass or carbon). These fibres may be randomly oriented or may be directionally arranged to provide added strength in a particular plane or direction.

NOTE The mechanical properties of composite materials are highly dependent on the arrangement of the reinforcement.

### 8.3 Coupling hubs

- **8.3.1** The purchaser shall specify the method used for attaching the coupling hubs to the machine shaft ends and shall allocate responsibility for the final machining of the hub bores.
- **8.3.2** The purchaser shall specify whether it is required to fit the coupling hubs to the shafts with proprietary clamping devices, and may specify the make and type of such devices. Acceptable clamping devices include tapered bushes, frictional locking assemblies and shrink discs. The body responsible for the final machining of the hub bores shall select a suitable rating/size device to suit the coupling and the application.

Care shall be exercised in the selection of these devices, as some are not inherently self-centring and can introduce eccentricity and unbalance into the coupling assembly. The eccentricity and unbalance effect shall be evaluated and allowed for when determining the coupling potential unbalance.

- **8.3.3** Where the hubs are keyed to the shafts, the purchaser shall specify the number and configuration of the keys and keyways. Where the purchaser has failed to specify the number and configuration of the keys, a single key shall be assumed.

**8.3.4** Coupling hubs not provided with proprietary clamping devices shall be fitted to the shaft with an interference fit.

**8.3.5** Unless otherwise specified, cylindrical shafts shall be assumed to comply with ANSI/AGMA 9002 or ANSI/AGMA 9112 and the coupling hubs shall be bored to the following tolerances:

- for shafts of 50 mm diameter and smaller: ISO 286-2:1988, Grade N7;
- for shafts larger than 50 mm in diameter: ISO 286-2:1988, Grade N8.

Unless otherwise specified, keys and keyways and their tolerances shall be in accordance with ANSI/AGMA 9002 or ANSI/AGMA 9112, normal fit.

**8.3.6** Unless otherwise specified, tapered shaft ends not intended for the hydraulic fitting of hubs shall have a taper of 1:16 and shall be in accordance with ANSI/AGMA 9002 or ANSI/AGMA 9112. The keyway clearance and the dimensional tolerances of keys and keyways shall be in accordance with ANSI/AGMA 9002 or ANSI/AGMA 9112, normal fit.

The bore taper shall be checked prior to cutting the keyway, using a suitable plug gauge. A light coat of blueing shall be used for the check and the bore shall indicate at least a 70 % blued fit (surface contact) to the plug gauge. By agreement, an alternative method of demonstrating the correct fit may be used.

**8.3.7** Unless otherwise specified, hydraulically fitted hubs shall be in accordance with ANSI/AGMA 9003 or DIN 7190. The taper of tapered bores for hydraulically fitted hubs, unless otherwise specified by the purchaser and agreed by the vendor, shall be 1:24. The bore shall be checked by using a plug gauge furnished by the purchaser, from a matched plug and ring gauge set. A light coat of blueing shall be used for the check and the bore shall indicate at least an 85 % blued fit (surface contact) to the plug gauge. By agreement, an alternative method of demonstrating the correct fit may be used.

- **8.3.8** Where the coupling is retained on the shaft by a shaft-end nut or bolt, the coupling design shall provide adequate clearance for a suitable wrench. The purchaser shall provide details of the nut (or bolt) and the wrench used and specify the required clearance.

**8.3.9** The surface finish of the bore of keyed hubs shall be 3,2 µm arithmetic average roughness,  $R_a$ , or smoother. The surface finish of the bore of hydraulically fitted hubs shall be 0,8 µm arithmetic average roughness,  $R_a$ , or smoother.

**8.3.10** Keyed coupling hubs shall be provided with suitable threaded puller holes or other agreed facilities for hub removal.

NOTE This requirement to provide puller holes can result in a reduction of the maximum bore to a value smaller than that published in the vendor's catalogue.

**8.3.11** If the coupling vendor supplies coupling hubs that are finished bored by others, the hubs shall be provided with suitable reference surfaces with respect to which the concentricity of the finished bores can be verified.

## 8.4 Bolting

**8.4.1** All fasteners shall be in accordance with a recognized grade as defined in an International Standard or a national standard. The values of the mechanical properties of the fasteners used for coupling design purposes shall be in accordance with the relevant standard.

**8.4.2** For connections that it can be necessary to dismantle in the field, the coupling vendor shall specify the bolt tension required and how this is achieved and controlled. Where this is achieved by control of the tightening torque, the vendor shall specify whether this is in a dry or lubricated condition.

**8.4.3** Bolts shall be held within tolerances, on both dimensions and mass, sufficient to permit both interchange within the same set of bolts and substitution of a spare set of bolts without affecting the coupling integrity or resulting in the balance being outside the prescribed limits.

## 8.5 Electrical insulation

**8.5.1** If specified, the coupling shall be electrically insulated. The method of insulation and the materials used shall be subject to the purchaser's approval.

**8.5.2** If specified, and where the coupling design is such that contact between the two halves of the coupling is only through elastomeric elements or inserts, the vendor shall state the electrical resistance of the coupling and the extent to which this can be varied by the use of different elastomer formulations.

## 8.6 Alignment provision

Couplings shall be provided with suitable reference surfaces, for alignment purposes, machined with sufficient accuracy appropriate to the misalignment capability of the coupling. Provision shall be made for the attachment of alignment equipment to the coupling shaft-mounted assemblies, without the need to remove the spacer or dismantle the coupling in any way.

By agreement, this requirement may be relaxed if a method of alignment has been specified or agreed that makes it unnecessary.

## 8.7 Rotor dynamic data

If requested, the vendor shall furnish the purchaser, or, by agreement, the vendor having unit responsibility (where different), with all the necessary data to enable the performance of lateral and torsional dynamic analyses of the coupled machines and of the whole train.

NOTE It is not expected that this will be necessary for the majority of general-purpose applications.

## 8.8 Non-horizontal applications

- The requirements of this International Standard have been developed primarily for couplings used between horizontal shafts. The purchaser shall specify if the coupling is to be used in a non-horizontal position.

## 8.9 Additional requirements for gear couplings

- **8.9.1** The purchaser may specify whether the coupling shall have the external teeth on the hub (sometimes referred to as a flex-hub coupling) or on the spacer (sometimes referred to as a marine-type coupling). A coupling may have a different arrangement of teeth at the two planes of flexure or the flexible element at one plane of flexure may be of a different type, such as a metallic flexible-element type.

NOTE General-purpose gear couplings usually have the external teeth on the hub.

**8.9.2** The design and materials of the teeth shall be such that the axial length of the teeth expected to suffer the most rapid wear shall be less than the axial length of the mating teeth. The difference in length shall be not less than the total maximum continuous axial displacement.

**8.9.3** General-purpose gear couplings shall be designed for batch lubrication unless otherwise specified. The vendor shall state the type of lubricant and the method and frequency of replenishment. If batch lubrication is not considered acceptable, consideration should be given to using a coupling in accordance with ISO 10441.

## 8.10 Additional requirements for metallic flexible-element couplings

**8.10.1** If the metallic flexible elements of a coupling are combined into a factory-assembled pack, unless otherwise agreed, the coupling spacer shall be removable without disturbance of the factory assembly of the elements.

**8.10.2** If two flexible elements or packs are used in close proximity as a pair in order to increase the misalignment capability, they shall be considered to provide only one plane of flexure and shall not be considered to provide any parallel or lateral offset capability.

- **8.10.3** A metallic flexible-element coupling can exhibit an undamped response to axial vibration. The vendor shall ensure that such an undamped axial vibration response, if it exists, cannot be excited by the specified operating conditions. If requested, the vendor shall provide evidence that this requirement has been satisfied.

NOTE With the possible exception of some metallic diaphragm couplings (for example single convoluted diaphragm types), which can occasionally be used, the majority of coupling types used for general purpose applications typically do not exhibit an undamped axial vibration response. A metallic diaphragm coupling is a type of metallic flexible-element coupling consisting of one or more metallic flexible elements in the form of thin, circular plates that are attached to one part of the coupling at their outer diameter and the other part at their inner diameter.

**8.10.4** Unless otherwise agreed, metallic flexible-element couplings shall be designed such that, in the event of complete failure of the flexible elements in one plane of flexure, the spacer is retained in such a position that it is sufficiently close to being parallel to the shaft axis that major damage to the machine or adjacent equipment is avoided. The use of bolt heads alone as a retention device after membrane failure is not acceptable since such arrangements can be subject to rapid wear.

## 8.11 Additional requirements for elastomeric couplings

**8.11.1** The elastomer shall be suitable for the environmental conditions, particularly temperature, specified by the purchaser.

**8.11.2** The vendor shall state the extent to which the torque rating of the coupling or its misalignment or axial displacement capability is dependent on temperature.

**8.11.3** Elastomeric flexible element couplings that employ a multiplicity of separate elastomeric elements shall be designed such that the elements are positively retained from being ejected, even in a worn or perished condition.

● **8.11.4** If specified, for single-engagement couplings, the vendor shall provide data on the forces and moments imposed on the shafts due to parallel or lateral offset, angular misalignment and axial displacement.

## 9 Balance

### 9.1 Objectives

**9.1.1** The overall objective is that the coupling shall be designed, manufactured, assembled, balanced, if necessary, and mounted on the shafts to ensure satisfactory operation of the coupled machines.

**9.1.2** The design and manufacture of couplings shall be such that the concentricity of components, sufficient to satisfy the balance requirements, is maintained even after repeated disassembly. Particular attention should be paid to proprietary clamping devices, where used.

**9.1.3** Unless otherwise agreed, the coupling shall be designed, manufactured and balanced, if necessary, such that it is possible to carry out any of the following operations in the field without the level of potential unbalance as specified in 9.2.1 being exceeded or the reliability of the coupling being affected:

- a) rearrangement of bolts within a set, or replacement of a complete set of bolts, in any connection that it can be necessary to disconnect in the field;
- b) replacement of the components carrying the gear teeth of a gear-type coupling, either as individual components or as match-marked meshing pairs, as specified by the vendor, or the wearing parts of other mechanical contact couplings;
- c) replacement of the flexible elements of a metallic flexible-element coupling, either as individual components or as factory-assembled sub-assemblies, as specified by the vendor;
- d) replacement of the elastomeric elements or inserts of an elastomeric flexible-element coupling;
- e) replacement of the spacer in the case of a coupling with a long spacer (longer than 500 mm);
- f) dismounting and remounting of a hub fitted with a proprietary clamping device.

### 9.2 Balance quality

**9.2.1** The potential unbalance of the coupling, mounted as specified on the shafts of the driving and driven machines, in the planes of the effective centres of mass of the half-couplings, shall not be greater than the largest of the following:

- unbalance equivalent to ISO 1940-1:2003, Grade 16, at the coupling rated speed;
- unbalance resulting from an eccentricity of the centre of mass of the half-coupling of 0,03 mm;
- 50 g·mm.

For the purpose of determining this potential unbalance, the vendor shall assume that the shaft end surfaces, on which the coupling hubs are mounted, are truly concentric with the centres of rotation of the driving and driven machines. However, account shall be taken of any eccentricity and/or tolerance in proprietary hub-clamping devices, where specified.

NOTE The method of calculating potential unbalance is explained, and a worked example is given, in Annex B.

- **9.2.2** If the purchaser requires a lower level of potential unbalance than specified in 9.2.1 because, for example, a particular application is sensitive to coupling unbalance, the purchaser and vendor shall agree what special measures shall be taken and, if necessary, which of the requirements of 9.1.3 may be waived. Alternatively, the purchaser should consider the use of a coupling in accordance with ISO 10441.

### 9.3 Additional balancing requirements

**9.3.1** The vendor shall describe in his operating instructions any precautions or special procedures necessary to ensure that the required level of balance is maintained in the field.

**9.3.2** Coupling hubs, other components, sub-assemblies, or complete couplings, with single keys or keyways, shall be balanced before the keyways are cut. Otherwise, due allowance shall be made for any difference between the mass of the key and the mass of material removed in machining the keyways. This shall be achieved in accordance with the “half-key convention” as defined in ISO 8821 or, with the purchaser’s approval, by the manufacturer’s standard method.

**9.3.3** If coupling hubs are supplied with unfinished bores, the coupling vendor shall balance the hubs, if necessary, with reference to the reference surfaces required by 8.6 and the potential unbalance shall be calculated assuming that these surfaces have a maximum eccentricity of 0,025 mm with respect to the axis of rotation.

### 9.4 Verification of coupling balance

- If specified, the purchaser and the vendor shall agree on the method used to verify that the level of potential unbalance, specified in 9.2.1, can be expected to be achieved in the field.

Possible methods to achieve this verification are given below.

- The vendor shall make available for review, by a representative of the purchaser or the end user, details of the methods of calculating the potential unbalance, the balancing procedures (including any methods used to “lock-up” or rigidize the flexing elements of a coupling for balancing purposes) and details of all assembly tolerances, concentricity limits, etc.
- The coupling or, where the coupling is of a type manufactured in batches, a similar coupling selected at random from a batch, shall be randomly assembled (except for factory-assembled sub-assemblies or matched-marked meshing pairs) and mounted in a balancing machine in a way that reproduces, as closely as possible, the manner in which it will be mounted in the field on the driving and driven shafts. The net unbalance in the planes of the effective centres of mass of the half-couplings shall be measured and shall be not greater than the potential unbalance specified in 9.2.1.

## 10 Accessories

The vendor shall supply all special tools required for assembly and disassembly of the coupling.

## 11 Manufacturing quality, inspection, testing and preparation for shipment

### 11.1 Manufacturing quality

Manufacturing processes, particularly welding, inspection and testing procedures and manufacturing methods for composite materials, shall be executed and controlled in accordance with a fully documented quality assurance system, which shall be available for review by the purchaser.

## 11.2 Inspection and testing

11.2.1 After advance notification of the vendor by the purchaser, the purchaser's representative shall be permitted entry to all vendor, manufacturer and sub-vendor plants where manufacturing, testing or inspection of the equipment is in progress.

NOTE Most components of couplings in accordance with this International Standard are manufactured in batches for stock and are not identified with a particular order prior to final assembly.

11.2.2 It is the manufacturer's responsibility to determine what tests and inspection procedures, in addition to any specified in this International Standard, are necessary to ensure that materials and finished components are satisfactory for the service.

11.2.3 If specified, the balance of the coupling shall be verified in accordance with 9.4.

## 11.3 Preparation for shipment

11.3.1 Before packing and shipment, all surfaces of the coupling shall be coated, as necessary, to prevent corrosion. Adequate instructions shall be provided covering the removal of such coatings and any other preparation required for installation or operation.

11.3.2 The purchaser shall specify whether any special packing requirements are necessary for either complete couplings or long-term replacement parts.

11.3.3 Unless otherwise specified, packaging shall be adequate to prevent mechanical and corrosion damage during normal shipment and for storage in an unheated building for not less than 12 months or such other period as may be specified.

## 12 Vendor's data

### 12.1 General

12.1.1 In 12.1.2, 12.2 and 12.3, the information that shall be furnished by the vendor is specified. Where the required data are adequately covered in a catalogue or other standard literature, reference to the relevant page, section or diagram of such documents suffices.

12.1.2 Data specific to a particular order shall be identified with the following information:

- a) purchaser's/user's corporate name;
- b) job/project number;
- c) name and item number of the coupled equipment;
- d) purchase order number;
- e) any other identification specified in the purchase order;
- f) vendor's identifying shop order number, serial number or other reference required to identify return correspondence completely.

### 12.2 Proposals

12.2.1 The vendor's proposal shall include the following information:

- a) statement that the coupling and all its components are in strict accordance with this International Standard and the purchaser's specifications; if the coupling and components are not in strict accordance, the vendor shall include a specific list of exceptions to this International Standard and its specifications that details and explains each deviation sufficiently to permit the purchaser to evaluate the offering;



- b) copies of the purchaser's data sheets with vendor's complete information entered thereon;
  - c) adequate information to fully describe the offerings;
  - d) itemized list of any special tools included in the offering.
- **12.2.2** If specified, the vendor shall provide a list of spare parts recommended for start-up and normal maintenance.

### 12.3 Contract data

**12.3.1** Subsequent to the receipt of an order, the following information shall be provided, preferably by completing the purchaser's data sheets:

- a) make, type and size of the coupling;
  - b) coupling continuous torque rating and transient torque capability;
  - c) coupling rated and maximum continuous speeds;
  - d) maximum permissible values of axial displacement and misalignment for continuous operation and for transient or intermittent operation;
  - e) potential unbalance;
  - f) all principal overall outline dimensions, and critical dimensions relating to the coupling-to-shaft attachment, such as hub-to-hub and shaft-end spacing, hub-bore details including tolerances, keyways, assumed hub-to-shaft interference fits and hub advances;
  - g) bolt-tightening requirements;
  - h) upper and lower temperature limits for elastomeric couplings;
  - i) materials of construction of major torque-transmitting components such as hubs, sleeves, spacers and flexible elements;
  - j) lubrication of a gear-type coupling.
- **12.3.2** If specified, the following additional data shall be provided:
    - a) effective mass and the location of the centre of mass of each half of the coupling (including an appropriate portion of the mass of the spacer);
    - b) axial reaction force; for mechanical contact couplings, this shall be based on the coupling rated torque and the vendor's stated coefficient of friction; for flexible-element couplings, this shall be based on the coupling rated maximum continuous axial displacement;
    - c) torsional stiffness and moment of inertia of complete coupling;
    - d) angular misalignment stiffness at each plane of flexure (that is, the bending moment imposed on the shaft end resulting from unit angular misalignment);
    - e) for single-engagement couplings, the lateral misalignment stiffness (that is, the bending moment and/or lateral force imposed on the shaft end resulting from unit parallel offset);
    - f) upper and lower temperature limits for metallic couplings;
    - g) where appropriate, for some types of elastomeric couplings, bending moments and/or lateral or axial forces imposed on the shaft end resulting from torque or speed-related effects.

Where appropriate, the data required in a) to g) above should be provided in the form of charts or curves.

**12.3.3** The vendor shall furnish a parts list for all equipment supplied. The list shall completely identify each part or sub-assembly that the vendor considers replaceable, so that the end user can determine the interchangeability of the part or sub-assembly with other couplings of the same make and type.

● **12.3.4** The vendor shall furnish the number of sets of installation and operating instructions for the coupling specified by the purchaser. At least one of these shall be shipped with the coupling. These shall include instructions covering installation, operating limits and maintenance procedures, in particular, instructions relating to the correct fitting of proprietary clamping devices, including bolt-tightening procedures.

## Annex A (informative)

### Examples of misalignment

Various types of misalignment are illustrated in Figures A.1 to A.4.

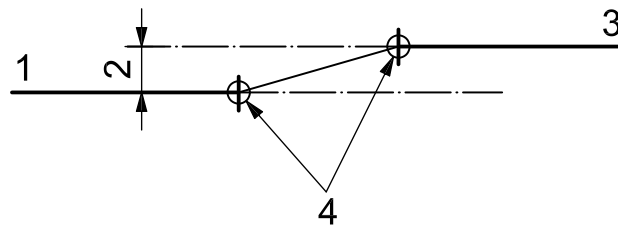

#### Key

- 1 driving machine
- 2 parallel offset
- 3 driven machine
- 4 planes of flexure

Figure A.1 — Parallel offset

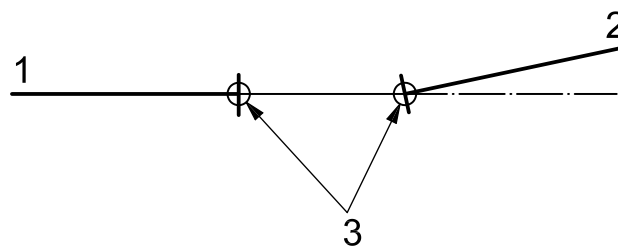

#### Key

- 1 driving machine
- 2 driven machine
- 3 planes of flexure

Figure A.2 — Angular misalignment

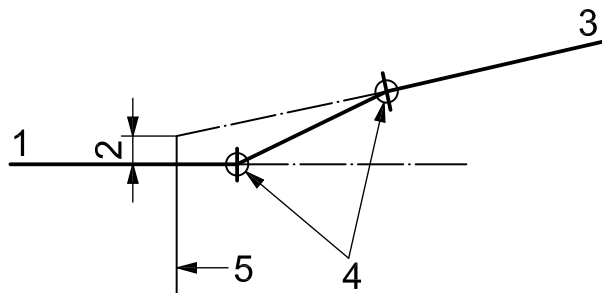

**Key**

- 1 driving machine
- 2 lateral offset
- 3 driven machine
- 4 planes of flexure
- 5 driving machine shaft end

**Figure A.3 — Lateral offset with angular misalignment in the same plane and in the same direction**

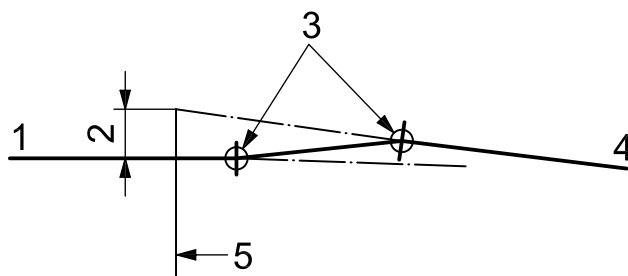

**Key**

- 1 driving machine
- 2 lateral offset
- 3 planes of flexure
- 4 driven machine
- 5 driving machine shaft end

**Figure A.4 — Lateral offset and angular misalignment in the same plane but in opposite directions**

## Annex B (informative)

### Example of the determination of potential unbalance

#### B.1 General

A typical flexible coupling consists of a number of components that are centred with respect to the axis of rotation by reference surfaces, such as the hub bores, and various pilots or registers (spigots or rabbets). The effective unbalance of such components is a combination of the residual unbalance of the component itself and the effect of the eccentricity of the mass of the component resulting from eccentricity and clearance in the various pilots or registers and other reference surfaces.

The net unbalance of the whole coupling is the summation of the effective unbalances of all the components. However, it is considered unreasonable to assume that all the contributory unbalances act in the same direction and it is, therefore, not considered appropriate to add all these contributory unbalances arithmetically.

The actual magnitude and direction of each contributory unbalance is assumed to be random in nature and the magnitude is assumed to have a normal (Gaussian) distribution, such that the assumed maximum is a fixed multiple of the standard deviation. The magnitude of the net unbalance of the whole coupling then also has a normal distribution, such that the maximum probable value (the potential unbalance) is the square root of the sum of the squares of all the contributory unbalances.

This is illustrated in Figure B.1, which shows a simplified representation of one-half of a flexible-element coupling, comprised of three parts: the hub, the flexible-element pack or assembly and one-half of the spacer.

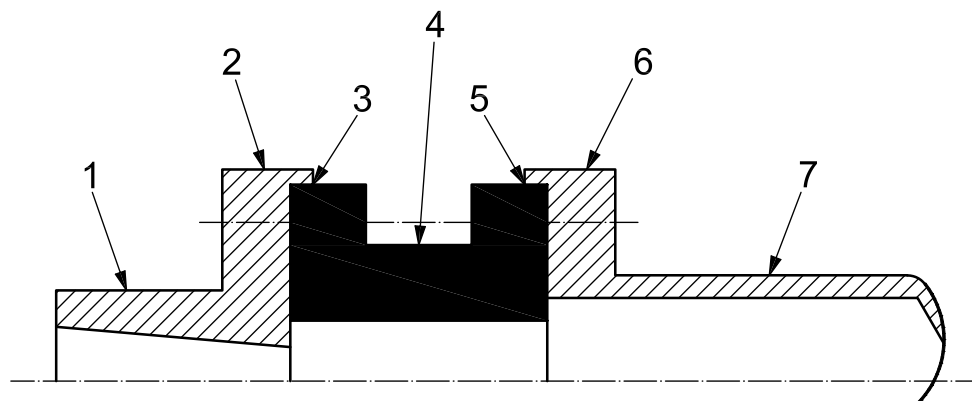

#### Key

- 1 hub
- 2 flange 1
- 3 pilot 1
- 4 flexible-element pack or assembly
- 5 pilot 2
- 6 flange 2
- 7 spacer

Figure B.1 — Typical flexible-element coupling

## B.2 Main characteristics

- maximum continuous speed: 3 000 r/min
- masses:
  - hub,  $M_h = 8$  kg
  - flexible-element assembly,  $M_f = 7$  kg
  - half-spacer,  $M_s = 6$  kg

## B.3 Balancing

- hub, balanced on a mandrel to ISO 1940-1:2003, Grade 6.3, which, at 3 000 r/min, allows the following:
  - mass eccentricity of 20  $\mu\text{m}$
  - maximum mandrel residual unbalance of 100 g·mm
  - maximum eccentricity of mounting surface,  $e_h$ , of 0,025 mm
  - maximum eccentricity of pilot 1 to bore,  $e_1$ , of 0,025 mm
- flexible-element assembly, locked on a fixture and balanced to ISO 1940-1:2003, Grade 6.3, with the following:
  - maximum fixture residual unbalance of 100 g·mm
  - maximum eccentricity of register (pilot 1) on fixture,  $e_f$ , of 0,025 mm
  - diametral clearance at register on fixture of zero
  - diametral clearance at hub connection (pilot 1) of zero
  - maximum eccentricity of pilot 1 to pilot 2,  $e_2$ , of 0,05 mm
- spacer, balanced, by rolling on the outer surface of the tube, to ISO 1940-1:2003, Grade 6.3, with the following:
  - maximum eccentricity of register to flex. assembly with respect to rolling surfaces,  $e_s$ , of 0,025 mm
  - clearance at register spacer-to-flexible-element assembly (pilot 2),  $c_s$ , of 0,025 mm
- bolting (both flanges), 8 ( $N$ ) bolts on 150 mm ( $D_b$ ) pitch circle diameter with the following:
  - maximum bolt-hole clearance,  $c_b$ , of 0,1 mm (diametral)
  - maximum variation in bolt-hole pitch radius,  $r_h$ , of 0,1 mm
  - mass of each bolt,  $M_b$ , of 50 g, with a maximum variation (heaviest to lightest),  $m_b$ , of 1 g
  - mass of each nut,  $M_n$ , of 10 g, with a maximum variation (heaviest to lightest),  $m_n$ , of 0,5 g

## B.4 Contributory unbalances

Table B.1 — Contributory unbalances

Contributory unbalance	Unbalance g·mm	Unbalance squared
Residual unbalance of hub: $M_h \times 20 = 20 \mu\text{m}$ (from ISO 1940-1:2003 G6.3 @ 3 000 r/min)	160	25 600
Unbalance of hub due to mandrel eccentricity: $M_h \times e_h =$	200	40 000
Unbalance of hub due to residual unbalance of hub mandrel:	100	10 000
Residual unbalance of flexible-element assembly: $M_f \times 20 =$	140	19 600
Unbalance of flex. assembly due to fixture register eccentricity: $M_f \times e_f =$	175	30 625
Unbalance of flexible-element assembly due to residual unbalance of fixture:	100	10 000
Residual unbalance of half-spacer: $M_s \times 20 =$	120	14 400
Unbalance of half-spacer due to eccentricity of register: $M_s \times e_s =$	150	22 500
Unbalance of flex. assembly plus half-spacer due to pilot 1 eccentricity: $[M_f + M_s + N(M_b + M_n)] \times e_1 =$	337	113 569
Unbalance of half-spacer due to eccentricity of pilot 1 to pilot 2: $M_s \times e_2 =$	300	90 000
Unbalance of half-spacer due to clearance at pilot 2: $(M_s \times c_s)/2 =$	75	5 625
Flange 1 unbalance due to bolt radial displacement: $N(M_b + M_n) \times (c_b/2 + r_b)/1\ 000 \sqrt{\quad} =$	25,46	648
Flange 2 unbalance due to bolt radial displacement: $N(M_b + M_n) \times (c_b/2 + r_b)/1\ 000 \sqrt{\quad} N =$	25,46	648
Flange 1 unbalance due to variation in mass of bolts: $m_b \times D_b/\pi \times \sqrt{\quad} (N/2) =$	95,49	9 119
Flange 1 unbalance due to variation in mass of nuts: $m_n \times D_b/\pi \times \sqrt{\quad} (N/2) =$	47,75	2 280
Flange 2 unbalance due to variation in mass of bolts: $m_b \times D_b/\pi \times \sqrt{\quad} (N/2) =$	95,49	9 119
Flange 2 unbalance due to variation in mass of nuts: $m_n \times D_b/\pi \times \sqrt{\quad} (N/2) =$	47,75	2 280
<b>Totals</b>	<b>1 552,2</b>	<b>417 412</b>

## B.5 Potential unbalance

The potential unbalance is equal to the square root of the sum of the squares,  $\sqrt{(417\ 412)}$ , which is equal to 646 g·mm.

With a total half-coupling mass of 21,48 kg, this is equivalent to 30,1 g·mm/kg; that is, less than that corresponding to ISO 1940-1:2003, Grade 16, at 3 000 r/min: 50,8 g·mm/kg. The coupling in this example therefore complies with the requirement of 9.2.

NOTE Reference can be made to ANSI/AGMA 9000 for the derivation of the equation used to calculate the various contributory unbalances and further information on the concept of potential unbalance.

## Annex C (informative)

### Coupling tapers

This International Standard mandates shaft ends with a taper of 1:24 (1/2 in of diameter per foot of length) for keyless hydraulically fitted hubs and a taper of 1:16 (3/4 in of diameter per foot of length) for non-hydraulically fitted hubs. It is recognized that other tapers exist; however, the tapers in this International Standard are mandated as a default standard in order to standardize for tooling purposes.

The greater the taper, the greater the accuracy that is demanded to position the hub axially on the shaft in order to maintain the stresses and contact pressures within given limits. Alternatively, the more shallow the taper, the less latitude there is in varying stresses and contact pressures because of the relatively large accompanying change in the spacer-gap dimension.

Table C.1 illustrates the axial hub advance required to achieve 25 µm (0,001 in) of bore dilation for three standard shaft-end tapers and for a 1° (included angle) taper.

As a further illustration, consider the case of a 125 mm (5 in) diameter bore that has an interference of 0,002 mm/mm (0,002 in/in) of bore diameter. This bore achieves a stress level of  $4,14 \times 10^8$  N/m<sup>2</sup> (60,000 psi). The total bore dilation is 0,25 mm (0,010 in), requiring an axial advance 10 times the values shown in the chart, that is, 14,5 mm, 6,0 mm and 4,0 mm (0,57 in, 0,24 in and 0,16 in), respectively, for the three standard tapers.

**Table C.1 — Axial hub advance required to achieve 25 µm (0,001 in) of bore dilation**

Taper	Axial advance required	
	mm	in
1° (included angle)	1,4	0,057
1:20 (0,60 in/ft)	0,5	0,020
1:24 (1/2 in/ft)	0,6	0,024
1:16 (3/4 in/ft)	0,4	0,016



## Annex D (normative)

### Coupling guards

#### D.1 Scope

This annex specifies the minimum requirements for coupling guards. Coupling guards are usually supplied by the machinery vendor rather than by the manufacturer or vendor of the coupling. This information is added for the convenience of the owner or the contractor in specifying the total requirements for the driving and driven equipment system.

#### D.2 General requirements for all guards

- **D.2.1** The purchaser shall designate who shall coordinate and be responsible for the supply of all coupling guards in the equipment train.
- **D.2.2** The purchaser shall specify the type of guard required.

**D.2.3** Each coupling shall have a coupling guard that sufficiently encloses the coupling and shafts to prevent any personnel from accessing the rotating parts during operation of the equipment train.

**D.2.4** The guard shall be readily removable for inspection and maintenance of the coupling without disturbance of the coupled machines.

**D.2.5** The guard shall be sufficiently rigid to withstand a 90 kg (200 lb) static load without any part of the guard coming into contact with moving parts.

**D.2.6** The guard shall comply with the requirements of any local codes or regulations, for example OSHA Standard 1910.219, or EN 953.

- **D.2.7** If specified, the guard shall be oil-tight.
- **D.2.8** If specified, the guard shall be fabricated from spark-resistant material such as aluminium, aluminium alloys, copper or copper-based alloys. A description of the materials of construction shall be submitted to the purchaser for approval.

**D.2.9** The guard shall include features to minimize the heat generated by the rotating components and shall have, as a minimum, a 25 mm (1 in) radial clearance between the maximum coupling outside diameter and the guard inside diameter. The vendor supplying the guard shall confirm the expected surface temperature of the guard. It is recommended that the maximum guard temperature not exceed 70 °C (160 °F). If the guard temperature exceeds this value, consideration should be given to providing personnel protection from contact with the guard.

#### D.3 Base-mounted guards

**D.3.1** Guards that are fastened to the equipment foundation or baseplate shall be removable in one piece.

**D.3.2** Base-mounted guards shall preferably be fabricated from solid metal sheet or plate with no openings. Guards that are fabricated from expanded metal or perforated plate are acceptable, provided that the size of any opening is small enough to prevent entry by objects that are 10 mm (3/8 in) or larger in diameter. Guards of woven wire are unacceptable.

## D.4 Fully enclosed guards

**D.4.1** Fully enclosed guards shall preferably be cylindrical in shape and shall be axially split with provision at each end for connection to the coupled equipment. If a slip joint is required at one end of the guard, the joint shall be provided with two O-rings. Alternatively, a flexible bellows or the equivalent may be used to accommodate expansion.

**D.4.2** If adapting flanges are required to mate the guard to the associated components of the equipment train, the vendor designated in D.2.1 shall be responsible for their design and supply.

**D.4.3** Fully enclosed guards shall be oil-tight and provided with vent and drain connections. As a minimum, these vent and drain connections shall be DN 25 (NPS1) and, if specified, flanged.

**D.4.4** If the guard is designed to cool the enclosure using an air flow, there should be at least two baffled inlet air vents, located in a separate plane from the exit air port(s). Note that the oil drain may also serve as the exit air port. This is so that air circulates throughout the enclosure. The air exit area should be at least twice the combined inlet vent area.

**NOTE** A technical paper by Calistrat and Munyon<sup>[4]</sup> provides guidelines for the design and evaluation of coupling guards for temperature conditions.

**D.4.5** A filter breather shall be supplied for attachment to the vent(s) unless otherwise specified. In applications where the vent is piped or included as part of the vent system for the equipment train, this connection shall be flanged, in which case the breather is not required. Drain connections shall be capable of handling the oil carry-over from the coupled equipment. It is recommended that the drain connection be tangential to the enclosure outside diameter and conform to the coupling direction of rotation.

**D.4.6** A baffle should be installed along the enclosure over the exit port to prevent the oil from rotating around more than one revolution before exiting. In guards 900 mm (36 in) in length or longer, it can be necessary to have two drains, one at each end, in planes different from those of the inlet vents if air cooling is used.

**D.4.7** The guard shall contain anti-swirl baffles as required to minimize the effects of windage.

**D.4.8** If specified, the guard shall be fitted with a connection for purging with dry air or an inert gas.

**NOTE** This is necessary when unusually corrosive conditions exist.

**D.4.9** If specified, the contract guard shall be used when the contract coupling is factory tested with the driver and driven equipment.

## D.5 Guards for instrumented couplings

In addition to requirements given above, guards containing instrumentation such as torque meters, shall be designed so that the internal temperature does not exceed the maximum temperature allowed for the enclosed instrumentation.

## **Annex E** (informative)

### **Coupling datasheets**

NOTE The datasheets in this annex are available as a separate file containing four electronic inserts and are, therefore, interactive.



Page 2 of 2 <p style="text-align: center;"><b>COUPLING DATASHEET</b>  <b>ISO 14691 - SI units</b></p>	Purchaser _____ Job no. _____ Owner _____ Site _____ Service _____ Item no. _____ Vendor _____																					
44	<b>Coupling selection</b>																					
45	Maker _____ Type / model _____ Size _____ Drawing no. _____																					
46	Vendor's catalogue ref. _____ Page / item No.: _____																					
47	<b>Data to be provided by vendor (12.3.1)</b>																					
48	Cplg. cont. torque rating [12.3.1 b)] [N·m] _____ Potential unbalance [12.3.1 e)] drive/driven end [g·mm] _____																					
50	Transient torque capability [12.3.1 b)]																					
51	<table border="1" style="width:100%; border-collapse: collapse;"> <thead> <tr> <th style="width:40%;"><u>Nature of transient</u></th> <th style="width:15%;"><u>Magnitude [N·m]</u></th> <th style="width:15%;"><u>No. of occurrences</u></th> <th style="width:30%;"><u>Notes</u></th> </tr> </thead> <tbody> <tr><td> </td><td> </td><td> </td><td> </td></tr> <tr><td> </td><td> </td><td> </td><td> </td></tr> <tr><td> </td><td> </td><td> </td><td> </td></tr> <tr><td> </td><td> </td><td> </td><td> </td></tr> </tbody> </table>	<u>Nature of transient</u>	<u>Magnitude [N·m]</u>	<u>No. of occurrences</u>	<u>Notes</u>																	
<u>Nature of transient</u>	<u>Magnitude [N·m]</u>	<u>No. of occurrences</u>	<u>Notes</u>																			
52																						
53																						
54																						
55	Cplg. rated speed [12.3.1 c)] [r/min] _____ Max. allowable speed [12.3.1 c)] [r/min] _____																					
56	Cplg. max. cont. axial displacement [12.3.1 d)] [mm]: at rated torque _____ Short-term transient: _____																					
57	Cplg. max. cont. overall angular misalignment [12.3.1 d)] [deg]: at rated torque: _____ Short-term transient: _____																					
58	Cplg. max. cont. parallel/lateral offset [12.3.1 d)] [mm]: at rated torque: _____ Short-term transient: _____																					
59	Drg. no. or catalogue figure reference giving all principle dimensions [12.3.1 f)] _____																					
60	Bolt tightening torques [12.3.1 g)] [N·m] _____																					
61	Temperature limits for elastomeric couplings [°C] [12.3.1 h)]: max.: _____ min.: _____																					
62	Lubrication: grease-packed / oil-filled / non-lube [12.3.1 j)] _____																					
63	<b>Materials of construction</b>																					
64	<table border="1" style="width:100%; border-collapse: collapse;"> <thead> <tr> <th style="width:30%;"></th> <th style="width:35%;"><u>Driving-end</u></th> <th style="width:35%;"><u>Driven-end</u></th> </tr> </thead> <tbody> <tr><td>65 Hub</td><td>_____</td><td>_____</td></tr> <tr><td>66 Spacer</td><td>_____</td><td>_____</td></tr> <tr><td>67 Flexible elements</td><td>_____</td><td>_____</td></tr> <tr><td>68 Sleeve</td><td>_____</td><td>_____</td></tr> <tr><td>69</td><td> </td><td> </td></tr> <tr><td>70</td><td> </td><td> </td></tr> </tbody> </table>		<u>Driving-end</u>	<u>Driven-end</u>	65 Hub	_____	_____	66 Spacer	_____	_____	67 Flexible elements	_____	_____	68 Sleeve	_____	_____	69			70		
	<u>Driving-end</u>	<u>Driven-end</u>																				
65 Hub	_____	_____																				
66 Spacer	_____	_____																				
67 Flexible elements	_____	_____																				
68 Sleeve	_____	_____																				
69																						
70																						
65																						
66																						
67																						
68																						
69																						
70																						
71	<b>Additional data to be provided when specified</b>																					
72	Effective half-coupling mass [12.3.2 a)] [kg]: Driving-end _____ Driven-end _____																					
73	Dist. of effective centre of mass of half-cplg. inboard of shaft end [12.3.2 a)] [mm] Driving-end _____ Driven-end _____																					
74	Max. axial force (at maximum continuous axial displacement for flex. element cplgs.) [12.3.2 b)] [N] _____																					
75	Torsional stiffness [12.3.2 c)] [MN·m/deg] _____ Overall moment of inertia ( $WR^2$ ) [12.3.2 c)] [kg·m <sup>2</sup> ] _____																					
76	Angular misalignment stiffness at each plane of flexure for double engagement coupling [12.3.2 d)] [N·m/deg] _____																					
77	Misalignment stiffness single engagement cplg. [12.3.2 e)] Bending [N·m/deg] _____ Lateral [N/mm] _____																					
78	Temperature limits for metallic couplings [12.3.2 f)] [°C]: max.: _____ min.: _____																					
79	Torque/speed effects in elastomeric couplings [12.3.2 g)] _____																					
80	Electrical resistance of coupling (8.5) [ohms] _____																					
81	<b>Notes:</b>																					
82																						
83																						
84																						
85																						
86																						

**E.2 USC unit datasheet**

Page 1 of 2 <div style="text-align: center;"><b>COUPLING DATASHEET</b> ISO 14691 - USC units</div>	Purchaser _____ Job no. _____ Owner _____ Site _____ Service _____ Item no. _____
1	Issued for inquiry/order no. _____ date _____ by _____ Revision no. _____ date _____ by _____
2	Completed for vendor, date _____ by _____ Revision no. _____ date _____ by _____
3	<b>Data to be provided by purchaser</b>
4	Type of coupling: metallic flexible element/gear/elastomeric/other (5.1) _____ No required _____
5	Coupling selection by method A / B / C (5.1.1) _____ Vendor to confirm purchaser's selection (5.1, 6.3): Yes / No
6	<b>Duty (6.3)</b>
7	Speeds [r/min]: Rated _____ Max continuous _____ Min continuous _____ Trip _____
8	Maximum torque required to be transmitted ( $T_m$ ) [lb-ft] _____ Service factor ( $K_s$ ) _____ Specified / Assumed
9	<u>Nature of transient torques</u> <u>Magnitude [lb-ft]</u> <u>No of occurrences</u>
10	
11	
12	
13	Momentary fault condition torque (6.5) [lb-ft] _____ Torque limiting device required (7.11): Yes / No
14	Misalignment capability required [6.3 f]: Angular [deg] _____ Lateral offset [in] _____ Axial displacement [in] _____
15	<b>Connected machines</b>
16	<u>Driving machine</u> <u>Driven machine</u>
17	Type / manufacturer [6.3 a] _____
18	Shaft dia. [in] / tapered / cyl. (8.3.1) _____
19	Proprietary clamping device (8.3.2) _____
20	No. of keys / configuration (8.3.3) _____
21	Hydraulic fit: Yes / No (8.3.7) _____
22	ANSI/AGMA 9002 / 9112 / other std. (8.3.5) _____
23	Sketch No. _____
24	Notes: _____
25	
26	
27	<b>Requirements</b>
28	Axial distance between shaft ends (6.4) [in] _____ Gear teeth on: sleeve / spacer / not applicable (8.9.1)
29	Minimum spacer gap length (8.1.2) [mm] _____ Maximum acceptable half-coupling mass (6.6) [in] _____
30	Reqd. torsional stiffness (6.6) [lb-ft/deg] _____ Data reqd. on forces and moments from misalignment (8.11.4): yes / no
31	Limited end float required (8.1.3): Yes / No    Float required [in] _____ Max. axial force to be transmitted (lb) _____
32	Flexing elements / Complete cplg. to be removable without moving coupled shafts (8.1.1, 8.1.2): Yes / No
33	On flexible element failure drive to be: maintained / disconnected (6.7, 8.10.4)                      Axis horizontal: Yes / No (8.8)
34	Coupling to be electrically insulated (8.5): yes / no    Electrical resistance and scope for variation to be stated: yes / no
35	Plug/ring gauge required (8.3.7): Yes / No    Supplied by _____ Ref No _____
36	Lubrication (8.9.3): oil/grease/none; batch/continuous    Evidence required that life can be achieved (5.1.3): Yes / No
37	Rotor-dynamic data reqd. (8.7): Yes / No    Spacer lat. crit. (8.1.5) [r/min] _____ Axial res. freq. (8.10.3) _____
38	Details of method to be made available to purchaser for: Balancing procedures / potential unbalance calc. (9.4)
39	Balance verification test required (9.4): Yes / No    Max. potential unbalance: as specified in this Int. Std. / other
40	<b>Site conditions [6.3 h]</b>
41	Temperature [°F]: Max. _____ Min. _____ Saline / dusty / corrosive elements _____
42	Storage: indoors / open    Duration [months / years] _____
43	

Page 2 of 2  <p style="text-align: center;"><b>COUPLING DATASHEET</b> ISO 14691 - USC units</p>	Purchaser _____ Job no. _____ Owner _____ Site _____ Service _____ Item no. _____ Vendor _____	
<b>44 Coupling selection</b>		
45 Maker _____ Type / model _____ Size _____ Drawing no. _____		
46 Vendor's catalogue ref. _____ Page / item No.: _____		
<b>47 Data to be provided by vendor (12.3.1)</b>		
48 Cplg. cont. torque rating [12.3.1 b)] [lb-ft] _____ Potential unbalance [12.3.1 e)] drive/driven end [lb-in] _____		
50 Transient torque capability [12.3.1 b)]		
51 <u>Nature of transient</u>	51 <u>Magnitude [lb-ft]</u>	
52 _____	52 _____	
53 _____	53 _____	
54 _____	54 _____	
54 _____	54 _____	
55 Cplg. rated speed [12.3.1 c)] [r/min] _____ Max. allowable speed [12.3.1 c)] [r/min] _____		
56 Cplg. max. cont. axial displacement [12.3.1 d)] [in]: at rated torque _____ Short-term transient: _____		
57 Cplg. max. cont. overall angular misalignment [12.3.1 d)] [deg]: at rated torque: _____ Short-term transient: _____		
58 Cplg. max. cont. parallel/lateral offset [12.3.1 d)] [in]: at rated torque: _____ Short-term transient: _____		
59 Drg. no. or catalogue figure reference giving all principle dimensions [12.3.1 f)] _____		
60 Bolt tightening torques [12.3.1 g)] [lb-ft] _____		
61 Temperature limits for elastomeric couplings [°F] [12.3.1 h)]: max.: _____ min.: _____		
62 Lubrication: grease-packed / oil-filled / non-lube [12.3.1 j)] _____		
<b>63 Materials of construction</b>		
	<u>Driving-end</u>	<u>Driven-end</u>
64 Hub	_____	_____
66 Spacer	_____	_____
67 Flexible elements	_____	_____
68 Sleeve	_____	_____
69 _____	_____	_____
70 _____	_____	_____
<b>71 Additional data to be provided when specified</b>		
72 Effective half-coupling mass [12.3.2 a)] [lb]: Driving-end _____ Driven-end _____		
73 Dist. of effective centre of mass of half-cplg. inboard of shaft end [12.3.2 a)] [in] Driving-end _____ Driven-end _____		
74 Max. axial force (at maximum continuous axial displacement for flex element cplgs.) [12.3.2 b)] [lb] _____		
75 Torsional stiffness [12.3.2 c)] [lb-ft/deg] _____ Overall moment of inertia ( $WR^2$ ) [12.3.2 c)] [lb-ft <sup>2</sup> ] _____		
76 Angular misalignment stiffness at each plane of flexure for double engagement coupling [12.3.2 d)] [lb-ft/deg] _____		
77 Misalignment stiffness single engagement cplg. [12.3.2 e)] Bending [lb-ft/deg] _____ Lateral [lb/ft] _____		
78 Temperature limits for metallic couplings [12.3.2 f)] [°F]: max.: _____ min.: _____		
79 Torque/speed effects in elastomeric couplings [12.3.2 g)] _____		
80 Electrical resistance of coupling (8.5) [ohms] _____		
81 <b>Notes:</b>		
82 _____		
83 _____		
84 _____		
85 _____		
86 _____		

## Bibliography

- [1] ANSI/AGMA 9000, *Flexible Couplings — Potential Unbalance Classification*<sup>3)</sup>
- [2] EN 953, *Safety of machinery — Guards — General requirements for the design and construction of fixed and movable guards*<sup>4)</sup>
- [3] OSHA 1910.219, *Subpart O — Machinery and Machine Guarding — Mechanical power-transmission apparatus*<sup>5)</sup>
- [4] CALISTRAT and MUNYON, *Design of Coupling Enclosures*, Proceedings of the Fourteenth Turbomachinery Symposium, The Turbomachinery Laboratory, Texas A & M University, College Station, Texas (1985)
- [5] ISO 10441, *Petroleum, petrochemical and natural gas industries — Flexible couplings for mechanical power transmission — Special-purpose applications*

---

3) American Gear Manufacturers Association, 1500 King Street, Suite 201, Alexandria, VA 22314, USA.  
4) Comité Européen de Normalisation, 36, rue de Stassart, Brussels, B-1050, Belgium.  
5) Occupational Safety and Health Administration, 200 Constitution Avenue, Washington, D.C. 20210, USA.





---

## BSI - British Standards Institution

BSI is the independent national body responsible for preparing British Standards. It presents the UK view on standards in Europe and at the international level. It is incorporated by Royal Charter.

### Revisions

British Standards are updated by amendment or revision. Users of British Standards should make sure that they possess the latest amendments or editions.

It is the constant aim of BSI to improve the quality of our products and services. We would be grateful if anyone finding an inaccuracy or ambiguity while using this British Standard would inform the Secretary of the technical committee responsible, the identity of which can be found on the inside front cover. Tel: +44 (0)20 8996 9000. Fax: +44 (0)20 8996 7400.

BSI offers members an individual updating service called PLUS which ensures that subscribers automatically receive the latest editions of standards.

### Buying standards

Orders for all BSI, international and foreign standards publications should be addressed to Customer Services. Tel: +44 (0)20 8996 9001. Fax: +44 (0)20 8996 7001 Email: [orders@bsigroup.com](mailto:orders@bsigroup.com) You may also buy directly using a debit/credit card from the BSI Shop on the Website <http://www.bsigroup.com/shop>

In response to orders for international standards, it is BSI policy to supply the BSI implementation of those that have been published as British Standards, unless otherwise requested.

### Information on standards

BSI provides a wide range of information on national, European and international standards through its Library and its Technical Help to Exporters Service. Various BSI electronic information services are also available which give details on all its products and services. Contact Information Centre. Tel: +44 (0)20 8996 7111 Fax: +44 (0)20 8996 7048 Email: [info@bsigroup.com](mailto:info@bsigroup.com)

Subscribing members of BSI are kept up to date with standards developments and receive substantial discounts on the purchase price of standards. For details of these and other benefits contact Membership Administration. Tel: +44 (0)20 8996 7002 Fax: +44 (0)20 8996 7001 Email: [membership@bsigroup.com](mailto:membership@bsigroup.com)

Information regarding online access to British Standards via British Standards Online can be found at <http://www.bsigroup.com/BSOL>

Further information about BSI is available on the BSI website at <http://www.bsigroup.com>.

### Copyright

Copyright subsists in all BSI publications. BSI also holds the copyright, in the UK, of the publications of the international standardization bodies. Except as permitted under the Copyright, Designs and Patents Act 1988 no extract may be reproduced, stored in a retrieval system or transmitted in any form or by any means – electronic, photocopying, recording or otherwise – without prior written permission from BSI.

This does not preclude the free use, in the course of implementing the standard, of necessary details such as symbols, and size, type or grade designations. If these details are to be used for any other purpose than implementation then the prior written permission of BSI must be obtained.

Details and advice can be obtained from the Copyright and Licensing Manager. Tel: +44 (0)20 8996 7070 Email: [copyright@bsigroup.com](mailto:copyright@bsigroup.com)