

BS EN ISO 14577-4:2016



BSI Standards Publication

Metallic materials — Instrumented indentation test for hardness and materials parameters

Part 4: Test method for metallic and non-metallic coatings (ISO 14577-4:2016)

National foreword

This British Standard is the UK implementation of EN ISO 14577-4:2016. It supersedes BS EN ISO 14577-4:2007 which is withdrawn.

The UK participation in its preparation was entrusted to Technical Committee ISE/101/5, Indentation hardness testing.

A list of organizations represented on this committee can be obtained on request to its secretary.

This publication does not purport to include all the necessary provisions of a contract. Users are responsible for its correct application.

© The British Standards Institution 2016.
Published by BSI Standards Limited 2016

ISBN 978 0 580 79989 1

ICS 77.040.10

Compliance with a British Standard cannot confer immunity from legal obligations.

This British Standard was published under the authority of the Standards Policy and Strategy Committee on 31 December 2016.

Amendments/corrigenda issued since publication

Date	Text affected
------	---------------

English Version

**Metallic materials - Instrumented indentation test for
hardness and materials parameters - Part 4: Test method
for metallic and non-metallic coatings (ISO 14577-4:2016)**

Matériaux métalliques - Essai de pénétration
instrumenté pour la détermination de la dureté et de
paramètres des matériaux - Partie 4 : Méthode d'essai
pour les revêtements métalliques et non métalliques
(ISO 14577-4:2016)

Metallische Werkstoffe - Instrumentierte
Eindringprüfung zur Bestimmung der Härte und
anderer Werkstoffparameter - Teil 4: Prüfverfahren für
metallische und nichtmetallische Schichten (ISO 14577-
4:2016)

This European Standard was approved by CEN on 1 October 2016.

CEN members are bound to comply with the CEN/CENELEC Internal Regulations which stipulate the conditions for giving this European Standard the status of a national standard without any alteration. Up-to-date lists and bibliographical references concerning such national standards may be obtained on application to the CEN-CENELEC Management Centre or to any CEN member.

This European Standard exists in three official versions (English, French, German). A version in any other language made by translation under the responsibility of a CEN member into its own language and notified to the CEN-CENELEC Management Centre has the same status as the official versions.

CEN members are the national standards bodies of Austria, Belgium, Bulgaria, Croatia, Cyprus, Czech Republic, Denmark, Estonia, Finland, Former Yugoslav Republic of Macedonia, France, Germany, Greece, Hungary, Iceland, Ireland, Italy, Latvia, Lithuania, Luxembourg, Malta, Netherlands, Norway, Poland, Portugal, Romania, Slovakia, Slovenia, Spain, Sweden, Switzerland, Turkey and United Kingdom.



EUROPEAN COMMITTEE FOR STANDARDIZATION
COMITÉ EUROPÉEN DE NORMALISATION
EUROPÄISCHES KOMITEE FÜR NORMUNG

CEN-CENELEC Management Centre: Avenue Marnix 17, B-1000 Brussels

European foreword

This document (EN ISO 14577-4:2016) has been prepared by Technical Committee ISO/TC 164 "Mechanical testing of metals" in collaboration with Technical Committee ECISS/TC 101 "Test methods for steel (other than chemical analysis)" the secretariat of which is held by AFNOR.

This European Standard shall be given the status of a national standard, either by publication of an identical text or by endorsement, at the latest by May 2017, and conflicting national standards shall be withdrawn at the latest by May 2017.

Attention is drawn to the possibility that some of the elements of this document may be the subject of patent rights. CEN [and/or CENELEC] shall not be held responsible for identifying any or all such patent rights.

This document supersedes EN ISO 14577-4:2007.

According to the CEN-CENELEC Internal Regulations, the national standards organizations of the following countries are bound to implement this European Standard: Austria, Belgium, Bulgaria, Croatia, Cyprus, Czech Republic, Denmark, Estonia, Finland, Former Yugoslav Republic of Macedonia, France, Germany, Greece, Hungary, Iceland, Ireland, Italy, Latvia, Lithuania, Luxembourg, Malta, Netherlands, Norway, Poland, Portugal, Romania, Slovakia, Slovenia, Spain, Sweden, Switzerland, Turkey and the United Kingdom.

Endorsement notice

The text of ISO 14577-4:2016 has been approved by CEN as EN ISO 14577-4:2016 without any modification.

Contents

Page

Foreword	iv
Introduction	v
1 Scope	1
2 Normative references	1
3 Symbols and designations	2
4 Calibration and direct verification of testing machines	2
5 Test pieces	2
5.1 General.....	2
5.2 Surface roughness.....	2
5.3 Polishing.....	3
5.4 Surface cleanliness.....	3
6 Procedure	4
6.1 Test conditions.....	4
6.2 Measurement procedure.....	5
6.2.1 General.....	5
6.2.2 Force control experiments.....	5
7 Data analysis and evaluation of results for indentation normal to the surface	5
7.1 General.....	5
7.2 Coating indentation modulus.....	6
7.3 Coating indentation hardness.....	9
8 Uncertainty of the results	15
9 Test report	15
Annex A (informative) Contact point and fully elastic regime	16
Bibliography	18

Foreword

ISO (the International Organization for Standardization) is a worldwide federation of national standards bodies (ISO member bodies). The work of preparing International Standards is normally carried out through ISO technical committees. Each member body interested in a subject for which a technical committee has been established has the right to be represented on that committee. International organizations, governmental and non-governmental, in liaison with ISO, also take part in the work. ISO collaborates closely with the International Electrotechnical Commission (IEC) on all matters of electrotechnical standardization.

The procedures used to develop this document and those intended for its further maintenance are described in the ISO/IEC Directives, Part 1. In particular the different approval criteria needed for the different types of ISO documents should be noted. This document was drafted in accordance with the editorial rules of the ISO/IEC Directives, Part 2 (see www.iso.org/directives).

Attention is drawn to the possibility that some of the elements of this document may be the subject of patent rights. ISO shall not be held responsible for identifying any or all such patent rights. Details of any patent rights identified during the development of the document will be in the Introduction and/or on the ISO list of patent declarations received (see www.iso.org/patents).

Any trade name used in this document is information given for the convenience of users and does not constitute an endorsement.

For an explanation on the meaning of ISO specific terms and expressions related to conformity assessment, as well as information about ISO's adherence to the World Trade Organization (WTO) principles in the Technical Barriers to Trade (TBT) see the following URL: www.iso.org/iso/foreword.html.

The committee responsible for this document is ISO/TC 164, *Mechanical testing of metals*, Subcommittee SC 3, *Hardness testing*.

This second edition cancels and replaces the first edition (ISO 14577-4:2007), which has been technically revised.

ISO 14577 consists of the following parts, under the general title *Metallic materials — Instrumented indentation test for hardness and materials parameters*:

- *Part 1: Test method*
- *Part 2: Verification and calibration of testing machines*
- *Part 3: Calibration of reference blocks*
- *Part 4: Test method for metallic and non-metallic coatings*

Introduction

The elastic and plastic properties of a coating are critical factors determining the performance of the coated product. Indeed, many coatings are specifically developed to provide wear resistance that is usually conferred by their high hardness. Measurement of coating hardness is often used as a quality control check. Young's modulus becomes important when calculation of the stress in a coating is required in the design of coated components. For example, the extent to which coated components can withstand external applied forces is an important property in the capability of any coated system.

It is relatively straightforward to determine the hardness and indentation modulus of bulk materials using instrumented indentation. However, when measurements are made normal to a coated surface, depending on the force applied and the thickness of the coating, the substrate properties influence the result.

The purpose of this part of ISO 14577 is to provide guidelines for conditions where a significant influence of the substrate is detected and to provide possible analytical methods to enable the coating properties to be extracted from the composite measurement. In some cases, the coating property can be determined directly from measurements on a cross-section.

Metallic materials — Instrumented indentation test for hardness and materials parameters —

Part 4: Test method for metallic and non-metallic coatings

1 Scope

This part of ISO 14577 specifies a method for testing coatings which is particularly suitable for testing in the nano/micro range applicable to thin coatings. However, the application of this method of this part of ISO 14577 is not needed if the indentation depth is such a small fraction of the coating thickness that in any possible case a substrate influence can be neglected and the coating can be considered as a bulk material. Limits for such cases are given.

This test method is limited to the examination of single layers when the indentation is carried out normal to the test piece surface, but graded and multilayer coatings can also be measured in cross-section if the thickness of the individual layers or gradations is greater than the spatial resolution of the indentation process.

The test method is not limited to any particular type of material. Metallic and non-metallic coatings are included in the scope of this part of ISO 14577. In this part of ISO 14577, the term coating is used to refer to any solid layer with homogeneous properties different to that of a substrate it is connected to. The method assumes that coating properties are constant with indentation depth. Composite coatings are considered to be homogenous if the structure size is less than the indentation size.

The application of this part of ISO 14577 regarding measurement of indentation hardness is only possible if the indenter is a pyramid or a cone with a radius of tip curvature small enough for plastic deformation to occur within the coating. The hardness of visco-elastic materials or materials exhibiting significant creep will be strongly affected by the time taken to perform the test.

NOTE 1 ISO 14577-1, ISO 14577-2 and ISO 14577-3 define usage of instrumented indentation testing of bulk materials over all force and displacement ranges.

NOTE 2 The analysis used here does not make any allowances for pile-up or sink-in of indents. Use of Atomic Force Microscopy (AFM) to assess the indent shape allows the determination of possible pile-up or sink-in of the surface around the indent. These surface effects result in an under-estimate (pile-up) or over-estimate (sink-in) of the contact area in the analysis and hence may influence the measured results. Pile-up generally occurs for fully work-hardened materials. Pile-up of soft, ductile materials is more likely for thinner coatings due to the constraint of the stresses in the zone of plastic deformation in the coating. It has been reported that the piled up material results in an effective increase of the contact area for the determination of hardness, while the effect is less pronounced for the determination of indentation modulus, since the piled up material behaves less rigidly.^{[1][2]}

2 Normative references

The following documents, in whole or in part, are normatively referenced in this document and are indispensable for its application. For dated references, only the edition cited applies. For undated references, the latest edition of the referenced document (including any amendments) applies.

ISO 14577-1:2015, *Metallic materials — Instrumented indentation test for hardness and materials parameters — Part 1: Test method*

ISO 14577-2:2015, *Metallic materials — Instrumented indentation test for hardness and materials parameters — Part 2: Verification and calibration of testing machines*

ISO/IEC Guide 98-3, *Uncertainty of measurement — Part 3: Guide to the expression of uncertainty in measurement (GUM)*

3 Symbols and designations

ISO 14577-1:2015, Table 1 provides a listing of symbols and their related designations. Additional symbols and designations used in this international standard are included in [Table 1](#).

Table 1 — Symbols and designations

Symbol	Designation	Unit
a	Radius of contact	mm
t_c	Thickness of the coating	mm
E_{ITc}	Indentation modulus of the coating	GPa
E_{ITc}^*	Indentation plane-strain modulus of the coating	GPa
H_{ITc}	Indentation hardness of the coating	GPa

4 Calibration and direct verification of testing machines

The instrument shall be calibrated and directly verified according to the procedures set out in ISO 14577-2:2015, Clause 4.

Indirect verification according to the procedure specified in ISO 14577-2:2015, Clause 5, using a reference material, shall be made to ensure that a new direct verification is not needed and that no damage or contamination has occurred to the indenter tip.

Indentation experiments may be performed with a variety of differently shaped indenters which should be chosen to optimize the plastic and elastic deformation required for a given coating substrate system. Typical indenter shapes are Vickers, Berkovich, conical, spherical and corner cube.

For the determination of coating plastic properties, pointed indenters are recommended. The thinner the coating, the sharper the indenter should be. For the determination of coating elastic properties, any geometry indenter may be used provided that its area function is known. If only the elastic properties of the coating are required, indentations in the fully elastic regime are recommended (if possible) as this avoids problems due to fracture, pile-up and high creep rates. A larger radius indenter tip or sphere will allow fully elastic indentations over a larger force range than a smaller radius indenter. However, too large a radius and surface effects will dominate the measurement uncertainties (roughness, surface layers, etc.). Too small a radius and the maximum force or displacement before plastic deformation begins will be very low. The optimum can be identified by preliminary experiments or modelling (see [Clause 7](#)).

5 Test pieces

5.1 General

Generally, surface preparation of the test piece should be kept to a minimum and, if possible, the test piece should be used in the as-received state if the surface condition conforms to the criteria given in [5.2](#), [5.3](#) and [5.4](#).

5.2 Surface roughness

Indentation into rough surfaces will lead to increased scatter in the results with decreasing indentation depth (see ISO 14577-1:2015, Annex E). Clearly, when the roughness value, R_a , approaches the same value as the indentation depth, the contact area will vary greatly from indent to indent depending on its position relative to peaks and valleys at the surface. The final surface finish should be as smooth

as available experience and facilities permit. The R_a value should be less than 5 % of the maximum penetration depth whenever possible.

NOTE It has been shown that for a Berkovich indenter, the angle that the surface normal presents to the axis of indentation has to be greater than 7° for significant errors to result.^[3] The important angle is that between the indentation axis and the local surface normal at the point of contact. This angle may be significantly different from the average surface plane for rough surfaces.

While R_a has been recommended as a practical and easily understood roughness parameter, this is an average. Thus, single peaks and valleys may be greater than this as defined by the R_z value, although the likelihood of encountering the maximum peak, for example, on the surface is small. Modelling to investigate the roughness of the coating surface^{[4][5]} has concluded that there are two limiting situations for any R_a value. When the “wavelength” of the roughness (in the plane of the coating surface) is much greater than the indenter tip radius, the force-penetration response is determined by the local coating surface curvature, but when the wavelength is much less than the tip radius, asperity contact occurs and the effect is similar to having an additional lower modulus coating on the surface.

In cases where coatings are used in the as-received condition, random defects (such as nodular growths or scratches) might be present. Where an indentation site imaging system is included in the testing machine, it is recommended that “flat” areas away from these defects be selected for measurement.

The radius of the roughness profilometer probe should be less than the indenter radius. If the roughness parameter R_a is determined with an AFM on a scan area, a scan area of $10\ \mu\text{m} \times 10\ \mu\text{m}$ is recommended.

Some instruments are capable of scanning the indentation site before indentation. In this case, areas with the required local slope and roughness may be selected for indentation in surfaces that might otherwise, on average, be too rough.

5.3 Polishing

It should be appreciated that mechanical polishing of surfaces can result in a change in the work hardening and/or the residual stress state of the surface and, consequently, the measured hardness. For ceramics, this is less of a concern than for metals, although surface damage can occur. Grinding and polishing shall be carried out such that any stress induced by the previous stage is removed by the subsequent stage, and the final stage shall be with a grade of polishing medium appropriate to the displacement scale being used in the test. If possible, electrochemical polishing should be used.

NOTE 1 Many coatings replicate the surface finish of the substrate. If it is acceptable to do so, surface preparation problems can be reduced by ensuring that the substrate has an appropriate surface finish, thus eliminating the need to prepare the surface of the coating. In some cases, however, changing the substrate surface roughness may affect other coating properties; therefore, care should be taken when using this approach.

NOTE 2 In coatings, it is common to get relatively large residual stresses (e.g. arising from thermal expansion coefficient mismatch between the coating and the substrate and/or stress induced by the coating deposition process). Thus, a stress-free surface would not normally be expected. Furthermore, stress gradients in coatings are not uncommon, so that removal of excessive material during a remedial surface preparation stage may result in a significant departure from the original surface state.

NOTE 3 Polishing reduces the coating thickness and so the effects of the substrate will be enhanced when indenting normal to the surface. Where the data analysis requires an accurate knowledge of the coating thickness indented, polishing will require re-measurement of coating thickness. This again emphasizes the need to carry out minimum preparation.

5.4 Surface cleanliness

Generally, provided the surface is free from obvious surface contamination, cleaning procedures should be avoided. If cleaning is required, it shall be limited to methods that minimize damage, for example

— application of dry, oil-free, filtered gas stream,

- application of subliming particle stream of CO₂ (taking care not to depress the surface temperature below the dew point), and
- rinsing with a solvent (which is chemically inert to the test piece) and then drying.

Ultrasonic methods are known to create or increase damage to coatings and should be used with caution.

6 Procedure

6.1 Test conditions

6.1.1 The indenter geometry, maximum force and/or displacement and force displacement cycle (with suitable hold periods) shall be selected by the operator to be appropriate to the coating to be measured and the operating parameters of the instrument used (see [Figure 1](#)).

Indentation hardness values are only valid if plastic deformation has occurred so that there is a residual indentation after force removal. Therefore, if both hardness and modulus are required from a single set of indentations, then a small radius tip is required and a self-similar geometry.

NOTE 1 A typical “small” radius for hardness measurement is that of a Berkovich indenter (<250 nm). A typical “large” radius for modulus measurement is <25 μm. In certain cases, a change of indenter can be avoided by force selection. The range of elastic deformation can be estimated by the formulae in [Annex A](#).

NOTE 2 An example of a simplified stress analysis is given in [7.3](#), Note 4.

6.1.2 Where multiple indentations normal to the surface or indentations in cross-section are planned, each indent shall be positioned and separated according to ISO 14577-1:2015, 7.7.

NOTE Coatings can display a high degree of anisotropy, and thus the orientation of the indenter within the plane and the direction of indentation (normal or cross-section) can significantly alter the measured value of the hardness and sometimes the modulus.

6.1.3 The parameters of the instrumented indentation test are defined according to ISO 14577-1:2015, 7.4.

The following parameters of coating/substrate influencing the measurement result should be considered:

- a) substrate hardness, Young’s modulus and Poisson’s ratio;
- b) coating thickness;
- c) surface roughness;
- d) adhesion of the coating to the substrate (delamination of the coating should be avoided).

All these parameters should be kept constant if a direct comparison of force displacement curves is to be made in order to detect a relative change in properties between two or more test pieces.

The time dependence of the material parameter being measured should be taken into account.

NOTE 1 Hardness and Young’s modulus values can be affected by adhesion. [\[6\]](#)[\[7\]](#)[\[8\]](#)[\[9\]](#)[\[10\]](#)

NOTE 2 Variations in test piece parameters other than hardness or modulus can affect measurement of these quantities. If the indentation depth is a sufficiently small fraction of the coating thickness, or the coating thickness may be reasonably well estimated and is constant for all indentation sites on a particular sample, it is possible to measure E_{ITC}^* and H_{ITC} without an accurate thickness measurement. If, however, the properties as a function of relative indentation depth are to be compared, an accurate thickness determination may be necessary. The exact limits depend on the ratio of properties of coating and substrate.

6.2 Measurement procedure

6.2.1 General

Introduce the prepared test piece and position it so that testing can be undertaken at the desired location.

Carry out the predetermined number of indentation cycles using the selected test conditions.

6.2.2 Force control experiments

A single force application and removal cycle shall be used. A decision tree to assist in estimating the drift during the experiment is shown in ISO 14577-1:2015, Annex G.

NOTE In case of displacement control measurements, the creep effects prevent an accurate determination of the slope of the unloading curve at maximum force and this will result in an incorrect hardness and modulus calculation. Furthermore, displacement control measurements do not allow thermal displacement drift correction.

7 Data analysis and evaluation of results for indentation normal to the surface

7.1 General

Before the data obtained during the indentation experiments can be analysed, it is necessary to have corrected the displacement data for significant thermal drift, determined the values of $A_p(h_c)$ and obtained C_s (the contact compliance) by correcting the data for the instrument frame compliance, C_f . The hardness and indentation modulus of the test piece can then be calculated using formulae in ISO 14577-1:2015, Annex A. ISO 14577-2:2015, Annex D describes the determination of C_s and C_f . The properties thus calculated according to ISO 14577-1 are composite properties for the coating/substrate combination. 7.2 and 7.3 provide methods for extracting the hardness and indentation modulus of the coating from the composite properties measured assuming that the coating properties are constant with depth.

NOTE 1 For indentation into a cross-section, the values obtained using ISO 14577-1 can be considered to be those of the coating, provided that the recommendations in 6.1.2 have been followed.

NOTE 2 Empirical guidelines are given in Reference [11] for hardness measurement of electroplated coatings on steels, where it is recommended that the indentation depth does not exceed one tenth the thickness of the coating.

Test parameters for ductile and brittle coatings shall be considered separately.

For indentation normal to the surface, elastic deformation of the substrate will always occur for all coatings, even though this could be negligibly small for a thick compliant coating on a stiff substrate. Thus, the measured modulus will always be the composite modulus of the coating and substrate, and the value obtained will be a function of indentation depth.

For hardness measurement, it is recommended to use as small a radius indenter as possible (i.e. as sharp as possible) to limit the plastic deformation to be within the coating. A measurement of the uncoated substrate hardness is a useful guide to the appropriate choice of analysis (soft vs. hard). In some circumstances, it is possible to identify a range of indentation depth over which the measured hardness is constant (i.e. before the onset of substrate plastic deformation) and then carry out indentation experiments within this range.

Estimates of coating hardness and modulus may be extracted from the composite values E_{IT}^* , H_{IT} obtained from indentation normal to the surface by expressing those composite values as a function of contact radius a or contact depth h_c normalized to coating thickness. Measurement of coating thickness, t_c , is not required to obtain an accurate intercept value. However, if data from different thickness coatings are to be plotted together, or the maximum range of indentation depth for valid data

is to be used, it is recommended to make a measurement of actual coating thickness to ensure the best reproducibility of results. For indenters of different geometries (e.g. Berkovich, Vickers, spherical, cone, etc.), a is approximated by the radius of a circle having the same area as the projected area of contact with the indenter according to [Formula \(1\)](#):

$$a = \sqrt{\frac{A_p}{\pi}} \quad (1)$$

This value has exact equivalence for a spherical or conical indenter but becomes increasingly less physically meaningful as the axial symmetry of the indenter reduces, i.e. cone = sphere > Vickers > Berkovich.

NOTE 3 It is relatively easy to measure the hardness of ductile coatings or the elastic modulus of brittle coatings. It is more difficult to determine the hardness of brittle or hard coatings or the elastic modulus of ductile coatings.

NOTE 4 Where t_c is not measured, nominal values of t_c may be used but comparison of data between coatings of different thicknesses will be less accurate.

7.2 Coating indentation modulus

In the case of force-controlled cycles and test pieces of unknown indentation response, a set of trial indentations shall be performed (e.g. at two widely spaced forces) and analysed to obtain estimates of the test force required for the range of a/t_c specified below. See [Figure 1](#) for the selection of suitable indenter geometry and indentation parameters.

The aim of the flow chart in [Figure 1](#) is to achieve indentations over a range of depths that do not fracture the coating, or creep, and are elastic if possible. A tip radius sufficiently large for an elastic indentation is recommended but may not always be possible. Where hardness is also required, see [6.1.1](#).

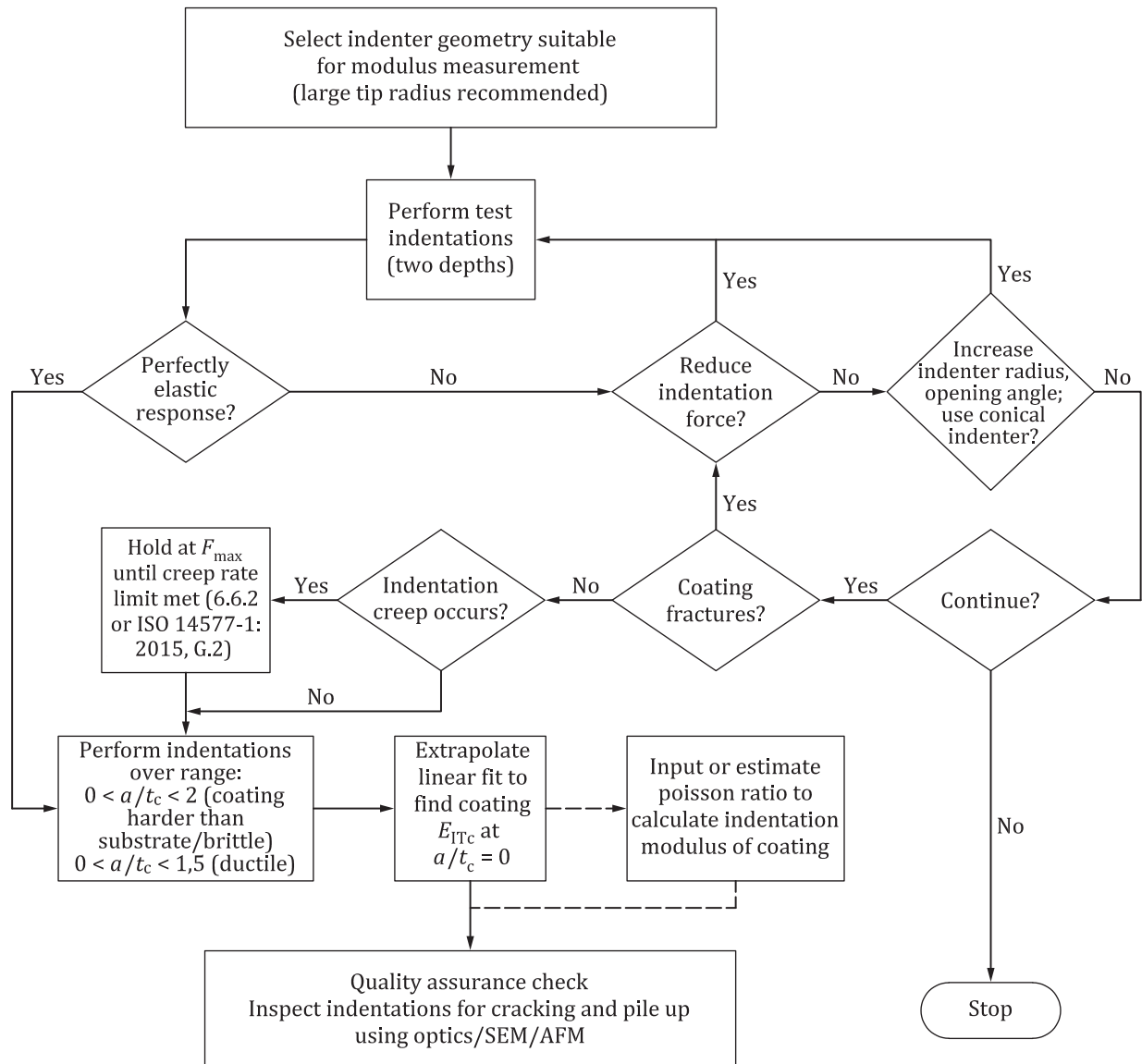

Figure 1 — Flow chart for selection of indenter geometry and indentation parameters to measure indentation modulus of coating

In the case of soft/ductile coatings, indentation force or displacement and indenter geometry shall be chosen such that data shall be obtained in the region where $a/t_c < 1,5$. The indentation modulus of the coating, E_{ITc} , is obtained by taking a series of measurements at different indentation depths and extrapolating a linear fit to indentation modulus, E_{IT} vs. a/t_c to zero^[1] (see [Figure 2](#)). The same procedure may be adopted using E_{IT}^* vs. a/t_c instead, leading to a plane strain indentation modulus value E_{ITc}^* for the coating.

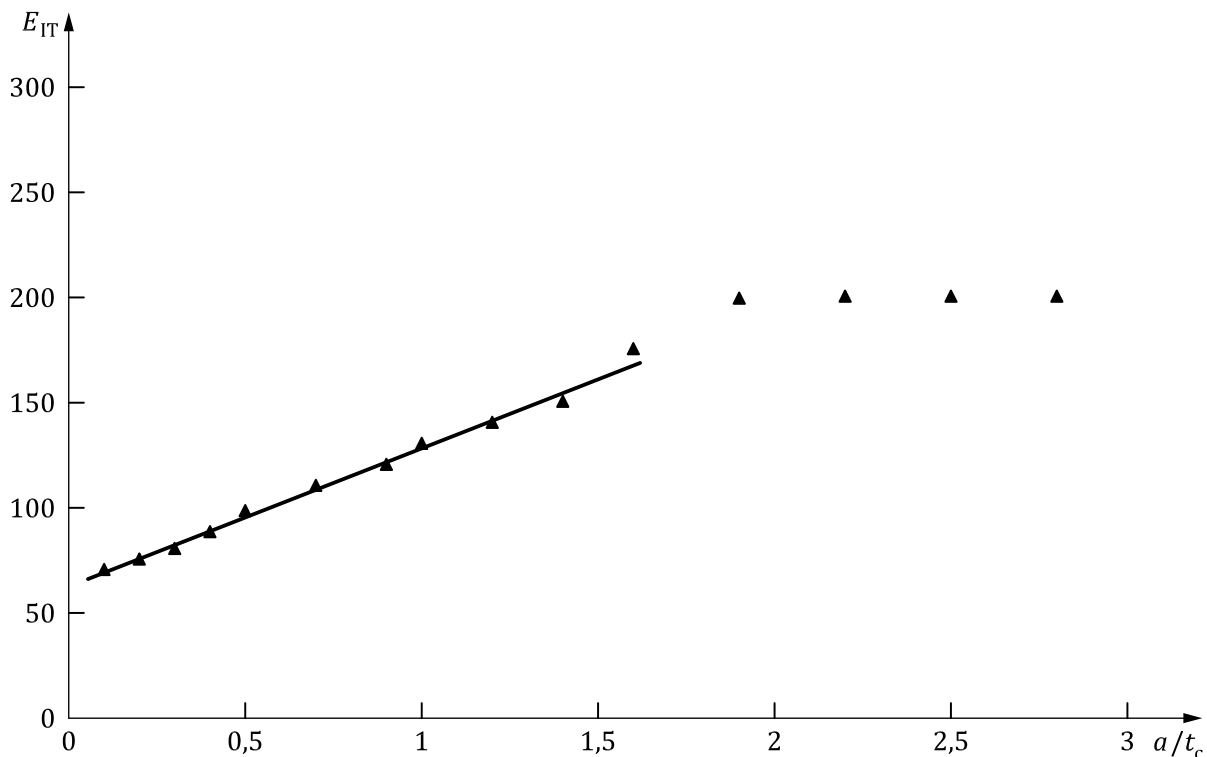

Figure 2 — Indentation modulus vs. normalized contact radius of a ductile coating on a harder substrate — Schematically

In the case of hard/brittle coatings, the indentation force or displacement and the indenter geometry shall be chosen such that data are obtained in the region where $a/t_c < 2$. The indentation modulus of the coating, E_{ITc} , is obtained by taking a series of measurements at different indentation depths and extrapolating a linear fit to the measured test piece indentation modulus, E_{IT} , vs. a/t_c to zero^[1] (see [Figure 3](#)).

NOTE 1 A linear fit to indentation modulus vs. a/t_c to zero is a first approximation. However, in general, a nonlinear relationship appears to apply and can be reproduced by finite element analysis (FEA). The exact nature of this nonlinear relation is not known and so a linear fit over the restricted range indicated is a robust first approximation but is not applicable over a range wider than this.

At least 15 measurements in total, distributed over 5 or more different values of a/t_c or h_c/t_c , shall be obtained before a valid extrapolation is possible. It is recommended that at least 50 measurements in total, distributed over 10 or more values of a/t_c or h_c/t_c , be obtained to reduce the uncertainties of the extrapolation. In general, it is recommended to increase the number of measurements made at different a/t_c or h_c/t_c values, in preference to increasing the replications at fewer a/t_c or h_c/t_c points.

NOTE 2 The quickest and most reliable method for determining the range of applied forces required to obtain indentation results in the required range of a/t_c or h_c/t_c is to perform a couple of trial indentations at different forces. Quick estimates of the likely h_c values for lower maximum applied forces can be obtained by drawing parallel lines to the tangent to the initial force removal curve.

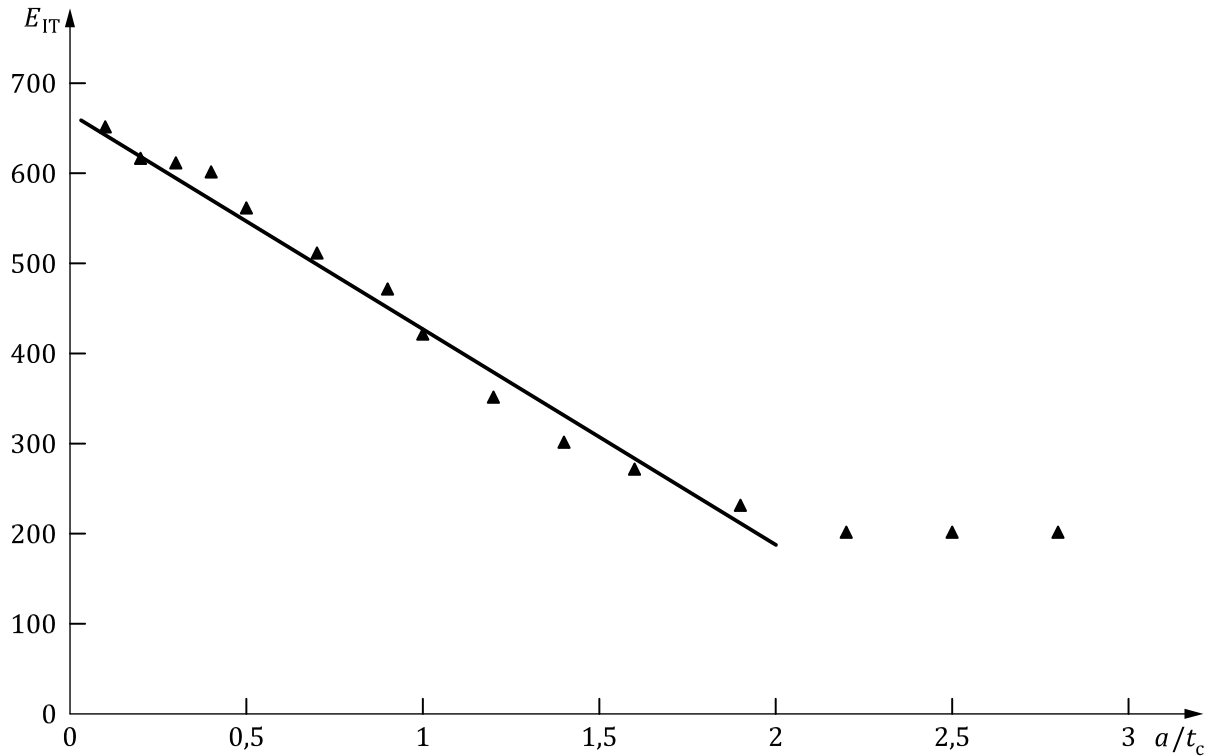

Figure 3 — Indentation modulus vs. normalized contact radius of hard brittle coating on a softer substrate — Schematically

7.3 Coating indentation hardness

The same normalized parameter, a/t_c , can be used for the evaluation of hardness results. However, since this method requires self-similar geometry indenters (pointed indenters), the non-dimensional parameter h_c/t_c (ratio of contact depth to coating thickness) can also be used. See [Figure 4](#) for the selection of suitable indenter geometry and indentation parameters.

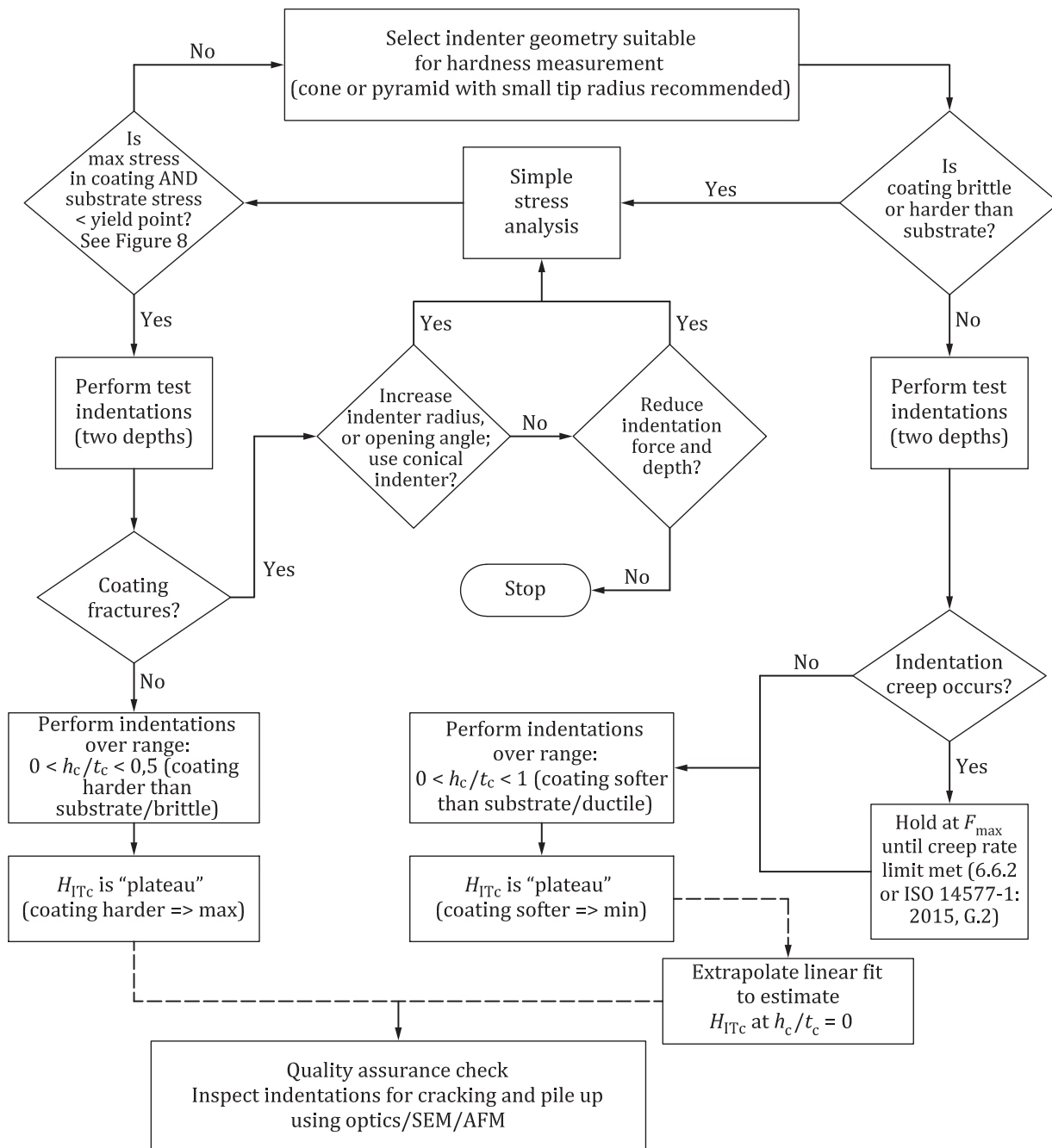

Figure 4 — Flow chart for selection of indenter geometry and indentation parameters to measure indentation hardness of coating

In the case of soft, ductile coatings on a harder substrate, the coating indentation hardness is obtained from an H_{IT} vs. h_c/t_c plot over the range $0 < h_c/t_c < 1$, provided the substrate is deformed only elastically. If a constant minimum value of H_{IT} (a plateau) is observed, this is the coating indentation hardness H_{ITc} (see [Figure 5](#)). If only a minimum in H_{IT} occurs and indentation of a thicker coating yields the same value, then this is a strong indicator that this is the value for the coating. Otherwise, this is only the maximum estimate of the coating indentation hardness. If no plateau is observed, the coating

indentation hardness is obtained from a linear extrapolation to zero of an H_{IT} vs. h_c/t_c plot over the range $0 < h_c/t_c < 1$ (see [Figure 6](#)).

NOTE 1 The maximum limit of h_c/t_c for a linear plot depends on the hardness ratio of the coating and substrate. For example, for an Au coating on Ni, the hardness ratio is approximately 2,5 and the h_c/t_c limit is <1 ; for an Al coating on optical glass (BK7) with a hardness ratio of approximately 8, the h_c/t_c limit is approximately 5. There is a lower limit of the contact depth to measure the hardness due to the tip rounding. A reproducible hardness value can be obtained for $h_c > 20\%$ of tip radius (for a 250 nm tip radius, this is 50 nm).

If the indentation size effect is getting a significant influence (measured hardness values go up for $h_c/t_c \rightarrow 0$), the calculation of H_{ITc} from the plateau of H_{IT} vs. h_c/t_c should exclude data points possibly governed by the indentation size effect.

It is recommended that at least 50 measurements in total, distributed over 10 or more values of a/t_c or h_c/t_c , be obtained to identify the plateau. In general, it is recommended to increase the number of measurements made at different a/t_c or h_c/t_c values, in preference to increasing the replications at fewer a/t_c or h_c/t_c points. This is particularly the case for hard/brittle coatings on a softer substrate, where the plateau of hardness values is to be determined.

In the case of hard coatings on a softer substrate, the coating indentation hardness can only be determined with a sharp (small tip radius) indenter that causes yielding within the coating. It is recommended that an elastic stress analysis of the coating/substrate system be undertaken using the approximation of a spherical indenter of a radius equivalent to the tip radius of the self-similar geometry indenter. This will determine whether the coating or the substrate will yield first during indentation and, therefore, whether it is possible to determine the coating hardness at all. It is recommended that hardness values for the substrate be obtained for comparison, by testing if necessary. Delamination or fracture of the coating can be recognized by the hardness values obtained clustering at the substrate value, even at low h_c/t_c . Note that sharper indenters may cause fracture at lower forces than more blunt indenters.

The indentation force or displacement and indenter geometry shall be chosen such that h_c/t_c (or approximately a/t_c) is in a range where H_{IT} is a maximum. Commonly, the range is $0 < h_c/t_c < 0,5$. If a constant maximum value of H_{IT} (a plateau) is observed over this range, this is the coating indentation hardness H_{ITc} ^[1] (see [Figure 7](#)). If only a maximum in H_{IT} occurs and indentation of a thicker coating yields the same value, then this is a strong indicator that this is the value for the coating. Otherwise, this is only the minimum estimate of the coating indentation hardness (see [Figure 8](#)).

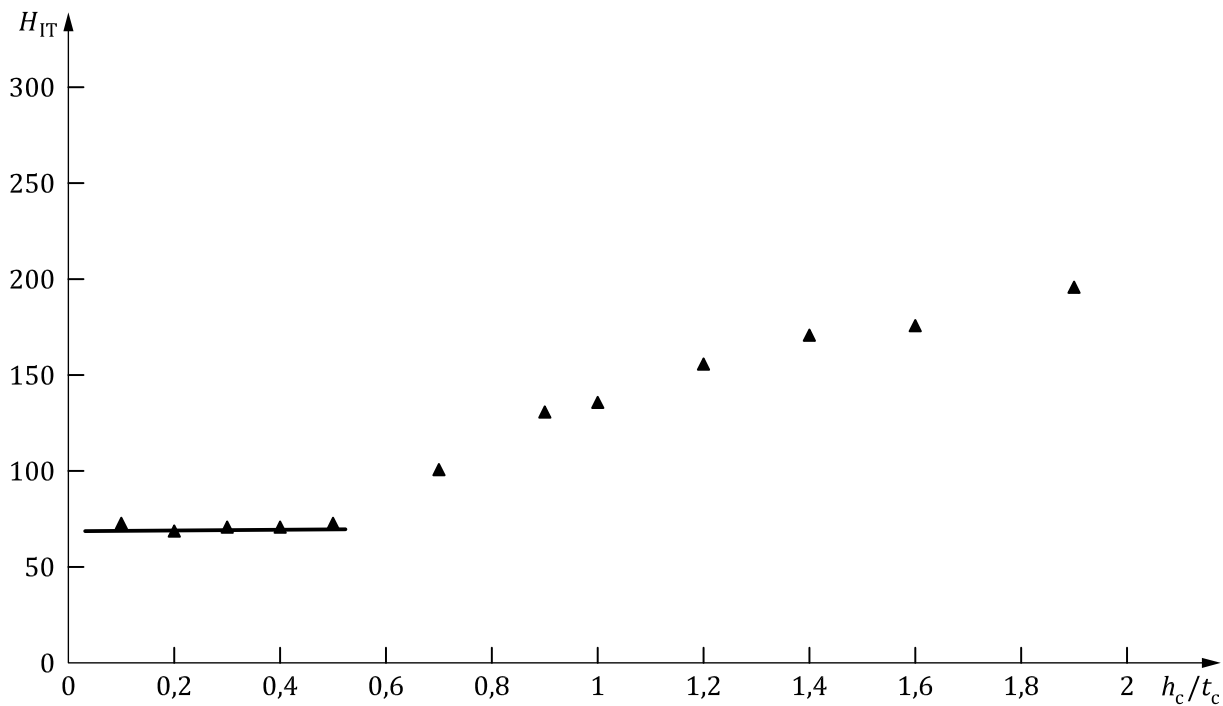

Figure 5 — Indentation hardness vs. normalized contact depth of a ductile coating on a harder substrate showing a constant minimum value “plateau” of H_{IT} — Schematically

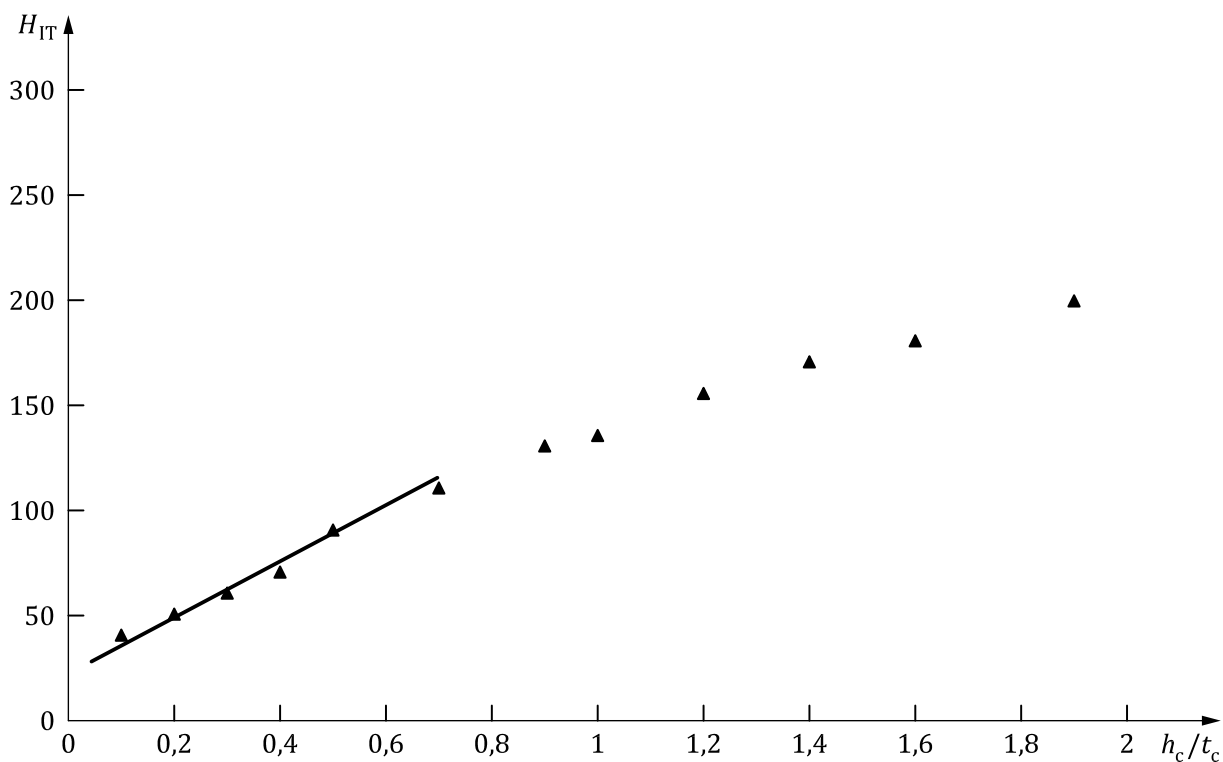

Figure 6 — Indentation hardness vs. normalized contact depth of a ductile coating on a harder substrate showing no constant minimum value of H_{IT} — Schematically

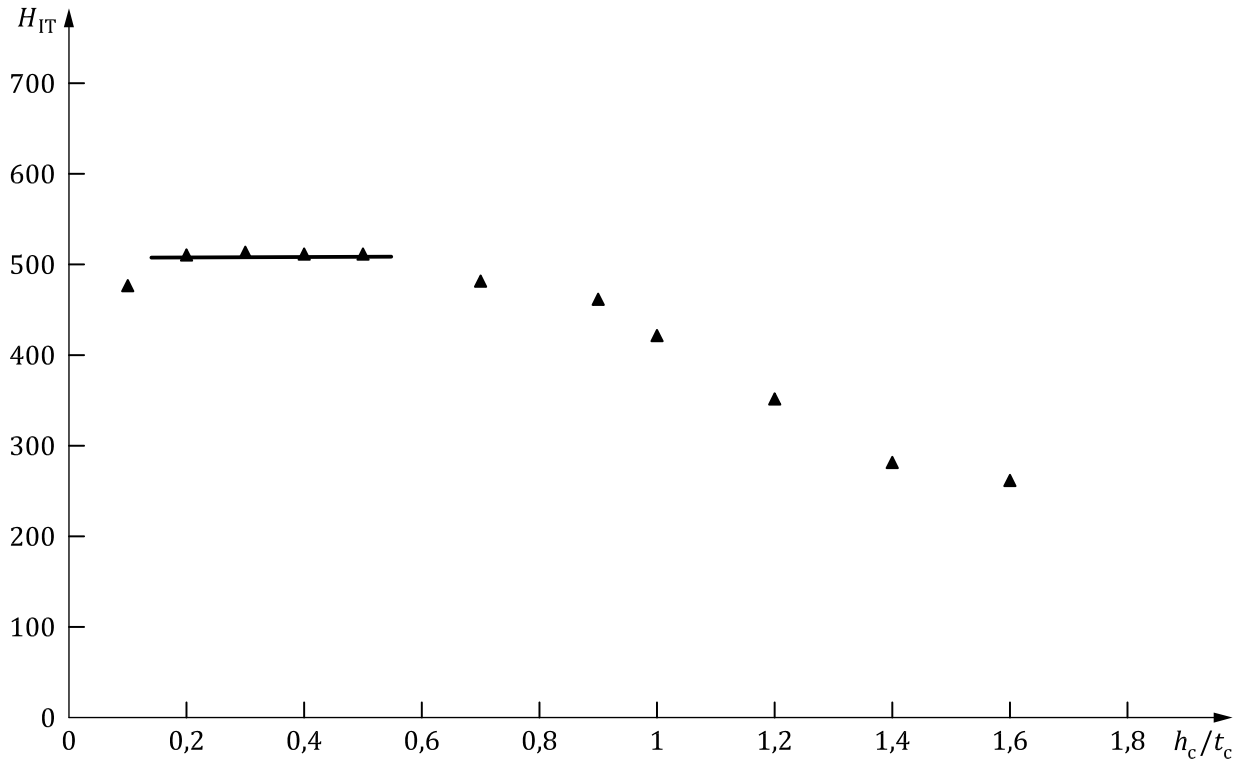

Figure 7 — Indentation hardness vs. normalized contact depth of a hard brittle coating on a softer substrate showing a constant maximum value “plateau” of H_{IT} — Schematically

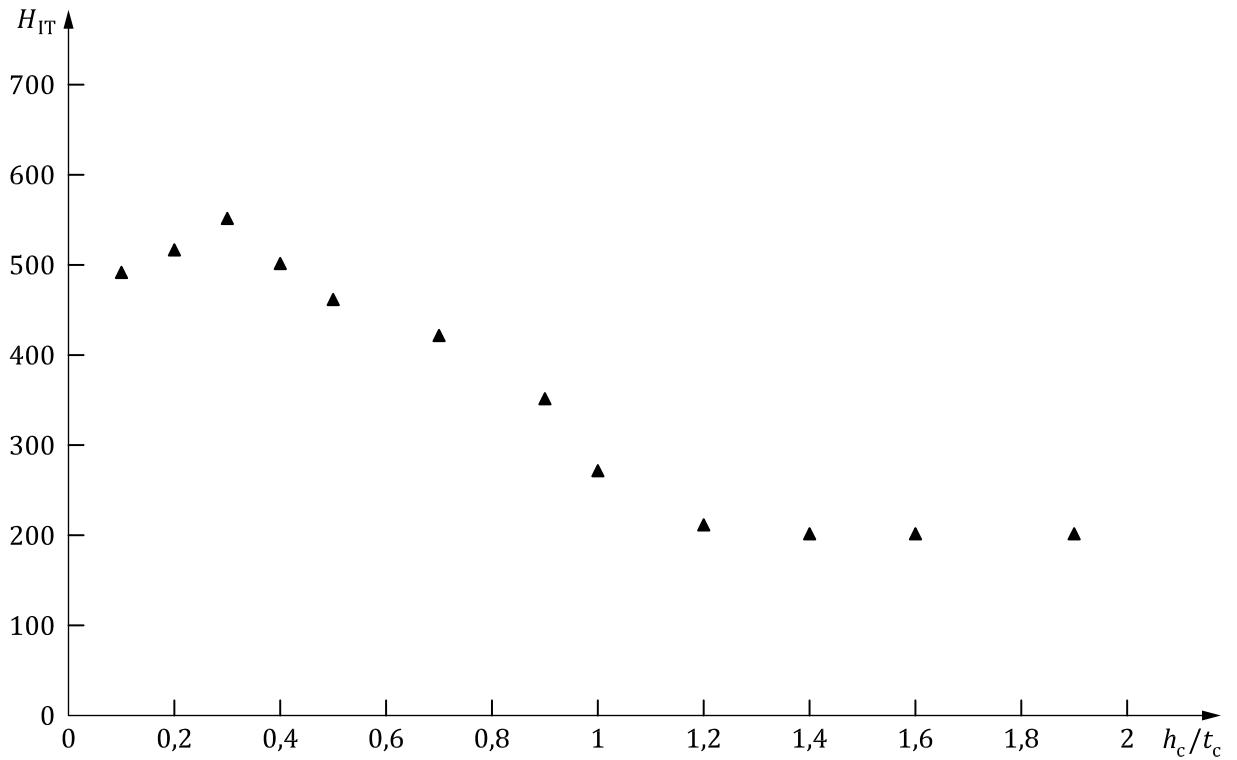
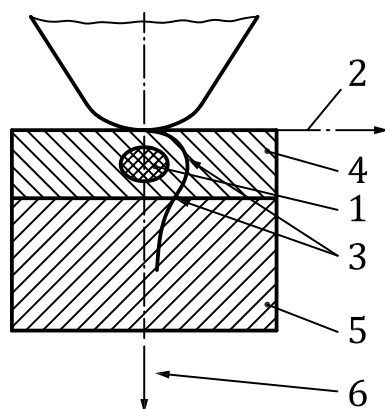

Figure 8 — Indentation hardness vs. normalized contact depth of a hard brittle coating on a softer substrate showing a single maximum value of H_{IT} — Schematically

NOTE 2 The extent of substrate plastic deformation will depend upon a number of factors, including the relative difference in hardness and modulus between the coating and the substrate, adhesion, the coating thickness, the indenter radius of curvature (“sharpness”) and the maximum force. Premature yielding of the substrate can be a particular problem in the case of hard and stiff coatings on softer substrates. However, if the coating modulus is much less than the substrate modulus, premature yielding of the substrate can also be caused (e.g. SiO₂ on tungsten). There is a compromise between

- a) using a sufficiently high force (e.g. close to but not exceeding the limit corresponding to the onset of plastic deformation of the substrate) in order to obtain the maximum of force-depth data, thereby improving the precision of the measurement, and
- b) indenting at a low enough displacement such that the plastic zone of the indentation does not interact with the substrate/coating interface, thus minimizing the influence of the substrate on the measurement (see [Figure 9](#)).

NOTE 3 Sharper indenters (lower radius tip and corners and/or smaller tip included angles) generally cause fracture at lower forces than blunter or lower aspect ratio indenters. Cracking can often be detected as sudden discontinuities or “pop-in” events in the load displacement curves of force-controlled indentations.



Key

- 1 plastic deformation
- 2 overlay of principal shear stress vs. depth under indenter
- 3 maximum shear stress in each material
- 4 coating
- 5 substrate
- 6 depth

NOTE Coating hardness is only measurable if coating yields first.

Figure 9 — Diagram of the principal shear stress as a function of depth under the indenter overlaid onto a diagram of an indentation into a coated substrate

NOTE 4 To measure the indentation coating hardness, there should be sufficient yielding of the coating before the substrate yields. The best conditions for this are when the maximum of the principal shear stress occurs inside the coating and causes plastic deformation while the stress in the substrate below does not exceed the substrate yield stress. For a fully elastic contact with a spherical indenter, the maximum of the principal shear stress is approximately 0,47 of the mean pressure for $\nu = 0,3$ at $0,5a$ below the surface.

NOTE 5 Different procedures have been published which suggest methods that may be used to determine the onset of substrate plastic deformation by the evaluation of the force increasing branch of the indentation hysteresis curve, but none has yet been validated by the international community. These involve a method^[12] in which the differential of the force with respect to displacement is plotted versus displacement, and the point of inflection is taken to be the depth at which plastic deformation of the substrate occurs. It has been proposed^[13] that departure from a linear relationship of force versus the square of displacement is also an indication of the onset of plastic deformation of the substrate. However, there is no guarantee that the yield or deviation detected is that of the substrate. Also, there is always a slight deviation from the linear relationship especially for depths where the tip rounding has an influence.

8 Uncertainty of the results

A complete evaluation of the uncertainty shall be carried out in accordance with ISO/IEC Guide 98-3. A detailed description of evaluation of uncertainty is given in ISO 14577-1:2015, Annex H.

9 Test report

The test report shall be in accordance with ISO 14577-1 and shall contain the following additional information:

- a) a description of the test piece (e.g. dimensions, nominal coating thickness, coating material and number of layers); if known, it is recommended to report
 - test piece preparation,
 - surface roughness R_a ,
 - substrate properties (composition, hardness and Young's modulus), and
 - actual coating thickness at the position of indentation;
- b) the distance between indentations;
- c) the information about the minimum and maximum depth;
- d) if the hardness value was estimated by extrapolation, the following sentence shall be included: "This value of hardness is a best estimate only. It is based upon the extrapolation of the hardness obtained between the ranges of indentation depths given."

Annex A (informative)

Contact point and fully elastic regime

For an accurate determination of the indentation depth, it is essential to be able to determine the point at which the indenter first touches the surface of the test piece. The contact point is determined by the first detected change of the test force, the contact stiffness or the rates of force or displacement during the initial loading cycle. Various instruments use different methods to determine the contact point, but the step size in force, displacement, force rate, displacement rate during the approach and subsequent force application shall be small enough to allow determination of the zero point to the required uncertainty (ISO 14577-1:2015, 7.3).

If initial data in the fully elastic regime are obtained, the determination of the contact point can be done by back-extrapolation using the Hertzian analytical relationships for spherical indentation.^{[1][14][15]}

The uncertainty in the zero point is affected by inhomogeneity of the sample (including the cracking of native oxide layers), surface roughness, the indenter geometry, the noise on the data (e.g. due to vibration), how well the mathematical function fits the trend in the data and the length of extrapolation (i.e. the size of the initial force). When indenting surfaces of homogeneous materials with an average roughness (at the indentation site) of less than 1 nm, where the data have a displacement noise of less than 1 nm and are extrapolated back from an initial force of between 0,002 mN and 0,05 mN using a mathematical function that closely describes the form of the data, it is possible to achieve zero point uncertainties in the range 0,1 nm to 2 nm. However, this estimate should not be relied upon in any specific instance as the actual uncertainty can be strongly affected by any or all of the factors identified above.

The indentation depth (fully elastic displacement), h , is given by [Formula \(A.1\)](#) and the radius of contact, a , is given by [Formula \(A.2\)](#)

$$h = \left(\frac{3F}{4E_r} \right)^{2/3} \cdot r^{-1/3} \quad (\text{A.1})$$

where

r is the radius of the indenter tip;

E_r is the reduced modulus of contact;

F is the applied force.

$$a = \sqrt{2 \cdot h \cdot r \cdot \left(1 - \frac{h}{2r}\right)} \quad (\text{A.2})$$

An elastic contact can be assumed if an indentation test with a maximum test force of at least two times the contact force shows sufficiently small differences between the curves of force application and force removal. After the thermal drift correction, the differences shall not exceed 1 nm or 3 % of the maximum depth (the smaller value shall be used).

NOTE First estimates for the displacement error introduced by an uncorrected depth offset for a given initial force can be derived from elastic theory [see [Formula \(A.1\)](#)]. In [Table A.1](#), elastic displacements for a range of material Young's moduli and indenter radii are given for initial contact forces of 1 μN , 5 μN and 10 μN . This is a minimum estimate assuming no plasticity.

In all cases, consideration should be given to the likely influence of (capillary) surface films on the surface detection or definition. These films can act to place additional unmeasured forces on the indentation and hence, obscure the real material response.

Table A.1 — Elastic indentation depth for different indenter radii

	Test force μN	Elastic indentation depth (nm) for different indenter radii (nm)					
		50	100	200	500	1 000	10 000
$E = 5 \text{ GPa},$ $\nu = 0,3$	1	7,22	5,72	4,55	3,35	2,66	1,23
	5	21,11	16,75	13,30	9,80	7,78	3,61
	10	33,51	26,60	21,11	15,55	12,34	5,73
$E = 20 \text{ GPa},$ $\nu = 0,3$	1	2,89	2,30	1,82	1,34	1,07	0,49
	5	8,46	6,71	5,33	3,93	3,12	1,45
	10	13,42	10,66	8,46	6,23	4,95	2,30
$E = 70 \text{ GPa},$ $\nu = 0,3$	1	1,29	1,03	0,81	0,60	0,48	0,22
	5	3,78	3,00	2,38	1,76	1,39	0,65
	10	6,01	4,77	3,78	2,79	2,21	1,03
$E = 100 \text{ GPa},$ $\nu = 0,3$	1	1,04	0,82	0,65	0,48	0,38	0,18
	5	3,04	2,41	1,91	1,41	1,12	0,52
	10	4,82	3,82	3,04	2,24	1,78	0,82
$E = 200 \text{ GPa},$ $\nu = 0,3$	1	0,69	0,55	0,44	0,32	0,25	0,12
	5	2,02	1,61	1,27	0,94	0,75	0,35
	10	3,21	2,55	2,02	1,49	1,18	0,55
$E = 400 \text{ GPa},$ $\nu = 0,3$	1	0,48	0,38	0,30	0,22	0,18	0,08
	5	1,41	1,12	0,89	0,65	0,52	0,24
	10	2,23	1,77	1,41	1,04	0,82	0,38

Bibliography

- [1] JENNETT N.M. Final Report EU-SMT Project: Determination of Hardness and Modulus of Thin Films and Coatings by Nanoindentation (INDICOAT), Contract No. SMT4-CT98-2249, *NPL Report MATC(A)*, **24**, May 2001
- [2] BOLSHAKOV A., & PHARR G.M. Influences of pile-up and the measurement of mechanical properties by load and depth sensing indentation techniques. *J. Mater. Res.* 1998, **13** pp. 1049–1058
- [3] MCCORMICK N.J., GEE M.G., HALL D.J. The calibration of the nanoindenter. *Proc. MRS.* 1993, **308** pp. 195–200
- [4] JIANG W.-G., SU J.-J., FENG X.-Q. Effect of surface roughness on nanoindentation test of thin films. *Eng. Fract. Mech.* 2008, **75** pp. 4965–4972
- [5] WALTER C., ANTRETTETTER T., DANIEL R., MITTERER C. Finite element simulation of the effect of surface roughness on nanoindentation of thin films with spherical indenters. *Surf. Coat. Tech.* 2007, **202** pp. 1103–1107
- [6] BURNETT P.J., & RICKERBY D.S. The scratch adhesion test: An elastic-plastic indentation analysis. *Thin Solid Films.* 1988, **157** pp. 233–254
- [7] BURNETT P.J., & RICKERBY D.S. The relationship between hardness and scratch adhesion. *Thin Solid Films.* 1987, **154** pp. 403–416
- [8] BURNETT P.J., & RICKERBY D.S. The mechanical properties of wear-resistant coatings: I: Modelling of hardness behaviour. *Thin Solid Films.* 1987, **148** pp. 41–50
- [9] BURNETT P.J., & RICKERBY D.S. The mechanical properties of wear-resistant coatings: II: Experimental studies and interpretation of hardness. *Thin Solid Films.* 1987, **148** pp. 51–65
- [10] PAGE T.F., & HAINSWORTH S.V. Using nanoindentation techniques for the characterization of coated systems: a critique. *Surf. Coat. Tech.* 1993, **61** pp. 201–208
- [11] ISO 4516:2002, *Metallic and other inorganic coatings — Vickers and Knoop microhardness tests*
- [12] ROTHER B., LUNOW T., LEONHARDT G. Interface strength of titanium nitride coatings on hardened high-speed steel. *Surf. Coat. Tech.* 1995, **71** pp. 229–232
- [13] HAINSWORTH S.V., & PAGE T.F. Analysis of nanoindentation load-displacement loading curves. *J. Mater. Res.* 1996, **11** pp. 1987–1995
- [14] CHUDOBA T., SCHWARZER N., RICHTER F. Determination of elastic properties of thin films by indentation measurements with a spherical indenter. *Surf. Coat. Tech.* 2000, **127** pp. 9–17
- [15] HERRMANN K., JENNETT N.M., WEGENER W., MENEVE J., HASCHKE K., SEEMANN R. Progress in determination of the area function of indenters used for nanoindentation, Proc ICMCTF00. *Thin Solid Films.* 2000, **377–378** pp. 394–400
- [16] NI W.Y., & CHENG Y.T. Modeling conical indentation in homogeneous materials and in hard films on soft substrates. *J. Mater. Res.* 2005, **20** pp. 521–528
- [17] CHUDOBA T., SCHWARZER N., RICHTER F., BECK U. Determination of mechanical film properties of a bilayer system due to elastic indentation measurements with a spherical indenter. *Thin Solid Films.* 2000, **377–378** pp. 366–372
- [18] ISO/IEC 17025, *General requirements for the competence of testing and calibration laboratories*
- [19] ISO 1514, *Paints and varnishes — Standard panels for testing*

- [20] SCHWARZER N. The extended Hertzian theory and its use in analysing indentation experiments. *Philos. Mag.* 2006, **86** pp. 5179–5197
- [21] SHIELD T.W., & BOGY D.B. Some axisymmetric problems for layered elastic media: Part 1 — Multiple region contact solutions for simply-connected indenters. *J. Appl. Mech.* 1989, **56** pp. 798–806
- [22] GAO H., CHIU C.-H., LEE J. Elastic contact versus indentation modeling of multi-layered materials. *Int. J. Solids Struct.* 1992, **29** pp. 2471–2492
- [23] MENCÍK J., MUNZ D., QUANDT E., WEPPELMANN E.R., SWAIN M.V. Determination of elastic modulus of thin layers using nanoindentation. *J. Mater. Res.* 1997, **12** pp. 2475–2484
- [24] SONG H. Selected mechanical problems in load- and depth-sensing indentation testing, *Rice University Ph. D. Thesis* (1999)
- [25] RAR A., SONG H., PHARR G.M. Assessment of new relation for the elastic compliance of a film-substrate system. *Proc. MRS.* 2001, **695** pp. 431–436
- [26] ROCHE S., BEC S., LOUBET J.L. Analysis of the elastic modulus of a thin polymer film. *Proc. MRS.* 2003, **778** pp. 117–122
- [27] SAHA R., & NIX W.D. Effects of the substrate on the determination of thin film mechanical properties by nanoindentation. *Acta Mater.* 2002, **50** pp. 23–38
- [28] CHUDOBA T., GRIEPENTROG M., DUCK A., SCHNEIDER D., RICHTER F. Young's modulus measurements on ultra-thin coatings. *J. Mater. Res.* 2004, **19** pp. 301–314
- [29] ISO 4287, *Geometrical Product Specifications (GPS) — Surface texture: Profile method — Terms, definitions and surface texture parameters*
- [30] ISO 2808, *Paints and varnishes — Determination of film thickness*
- [31] ISO 3270, *Paints and varnishes and their raw materials — Temperatures and humidities for conditioning and testing*
- [32] ISO 14577-3, *Metallic materials — Instrumented indentation test for hardness and materials parameters — Part 3: Calibration of reference blocks*

British Standards Institution (BSI)

BSI is the national body responsible for preparing British Standards and other standards-related publications, information and services.

BSI is incorporated by Royal Charter. British Standards and other standardization products are published by BSI Standards Limited.

About us

We bring together business, industry, government, consumers, innovators and others to shape their combined experience and expertise into standards-based solutions.

The knowledge embodied in our standards has been carefully assembled in a dependable format and refined through our open consultation process. Organizations of all sizes and across all sectors choose standards to help them achieve their goals.

Information on standards

We can provide you with the knowledge that your organization needs to succeed. Find out more about British Standards by visiting our website at bsigroup.com/standards or contacting our Customer Services team or Knowledge Centre.

Buying standards

You can buy and download PDF versions of BSI publications, including British and adopted European and international standards, through our website at bsigroup.com/shop, where hard copies can also be purchased.

If you need international and foreign standards from other Standards Development Organizations, hard copies can be ordered from our Customer Services team.

Copyright in BSI publications

All the content in BSI publications, including British Standards, is the property of and copyrighted by BSI or some person or entity that owns copyright in the information used (such as the international standardization bodies) and has formally licensed such information to BSI for commercial publication and use.

Save for the provisions below, you may not transfer, share or disseminate any portion of the standard to any other person. You may not adapt, distribute, commercially exploit, or publicly display the standard or any portion thereof in any manner whatsoever without BSI's prior written consent.

Storing and using standards

Standards purchased in soft copy format:

- A British Standard purchased in soft copy format is licensed to a sole named user for personal or internal company use only.
- The standard may be stored on more than 1 device provided that it is accessible by the sole named user only and that only 1 copy is accessed at any one time.
- A single paper copy may be printed for personal or internal company use only.

Standards purchased in hard copy format:

- A British Standard purchased in hard copy format is for personal or internal company use only.
- It may not be further reproduced – in any format – to create an additional copy. This includes scanning of the document.

If you need more than 1 copy of the document, or if you wish to share the document on an internal network, you can save money by choosing a subscription product (see 'Subscriptions').

Reproducing extracts

For permission to reproduce content from BSI publications contact the BSI Copyright & Licensing team.

Subscriptions

Our range of subscription services are designed to make using standards easier for you. For further information on our subscription products go to bsigroup.com/subscriptions.

With **British Standards Online (BSOL)** you'll have instant access to over 55,000 British and adopted European and international standards from your desktop. It's available 24/7 and is refreshed daily so you'll always be up to date.

You can keep in touch with standards developments and receive substantial discounts on the purchase price of standards, both in single copy and subscription format, by becoming a **BSI Subscribing Member**.

PLUS is an updating service exclusive to BSI Subscribing Members. You will automatically receive the latest hard copy of your standards when they're revised or replaced.

To find out more about becoming a BSI Subscribing Member and the benefits of membership, please visit bsigroup.com/shop.

With a **Multi-User Network Licence (MUNL)** you are able to host standards publications on your intranet. Licences can cover as few or as many users as you wish. With updates supplied as soon as they're available, you can be sure your documentation is current. For further information, email subscriptions@bsigroup.com.

Revisions

Our British Standards and other publications are updated by amendment or revision.

We continually improve the quality of our products and services to benefit your business. If you find an inaccuracy or ambiguity within a British Standard or other BSI publication please inform the Knowledge Centre.

Useful Contacts

Customer Services

Tel: +44 345 086 9001

Email (orders): orders@bsigroup.com

Email (enquiries): cservices@bsigroup.com

Subscriptions

Tel: +44 345 086 9001

Email: subscriptions@bsigroup.com

Knowledge Centre

Tel: +44 20 8996 7004

Email: knowledgecentre@bsigroup.com

Copyright & Licensing

Tel: +44 20 8996 7070

Email: copyright@bsigroup.com

BSI Group Headquarters

389 Chiswick High Road London W4 4AL UK