

BS EN ISO 14555:2014

Incorporating corrigendum August 2014



BSI Standards Publication

Welding — Arc stud welding of metallic materials (ISO 14555:2014)

bsi.

...making excellence a habit.™

National foreword

This British Standard is the UK implementation of EN ISO 14555:2014. It supersedes BS EN ISO 14555:2006, which is withdrawn.

The ISO corrected text 01 June 2014 incorporates the following editorial corrections:

- 9.5.6 was renumbered 9.6; consequently, subclauses 9.7 to 9.12 were also renumbered;
- in 11.1, “The methods described in 11.2 to 11.7 may be used ...” was replaced with “The methods described in 11.2 to 11.8 may be used ...”;
- in Table A.6, No. 5, the incorrect figure was replaced with the correct one;
- in Annex C, “ yes no” was replaced with “ yes no”.

The UK participation in its preparation was entrusted to Technical Committee WEE/-/1, Briefing committee for welding.

A list of organizations represented on this committee can be obtained on request to its secretary.

This publication does not purport to include all the necessary provisions of a contract. Users are responsible for its correct application.

© The British Standards Institution 2014.

Published by BSI Standards Limited 2014

ISBN 978 0 580 87641 7

ICS 25.160.10

Compliance with a British Standard cannot confer immunity from legal obligations.

This British Standard was published under the authority of the Standards Policy and Strategy Committee on 31 May 2014.

Amendments/corrigenda issued since publication

| Date | Text affected |
|----------------|---|
| 31 August 2014 | Implementation of ISO corrected text 01 June 2014 |

EUROPEAN STANDARD

EN ISO 14555

NORME EUROPÉENNE

EUROPÄISCHE NORM

April 2014

ICS 25.160.10

Supersedes EN ISO 14555:2006

English Version

Welding - Arc stud welding of metallic materials (ISO 14555:2014)

Soudage - Soudage à l'arc des goujons sur les matériaux métalliques (ISO 14555:2014)

Schweißen - Lichtbogenbolzenschweißen von metallischen Werkstoffen (ISO 14555:2014)

This European Standard was approved by CEN on 20 March 2014.

CEN members are bound to comply with the CEN/CENELEC Internal Regulations which stipulate the conditions for giving this European Standard the status of a national standard without any alteration. Up-to-date lists and bibliographical references concerning such national standards may be obtained on application to the CEN-CENELEC Management Centre or to any CEN member.

This European Standard exists in three official versions (English, French, German). A version in any other language made by translation under the responsibility of a CEN member into its own language and notified to the CEN-CENELEC Management Centre has the same status as the official versions.

CEN members are the national standards bodies of Austria, Belgium, Bulgaria, Croatia, Cyprus, Czech Republic, Denmark, Estonia, Finland, Former Yugoslav Republic of Macedonia, France, Germany, Greece, Hungary, Iceland, Ireland, Italy, Latvia, Lithuania, Luxembourg, Malta, Netherlands, Norway, Poland, Portugal, Romania, Slovakia, Slovenia, Spain, Sweden, Switzerland, Turkey and United Kingdom.



EUROPEAN COMMITTEE FOR STANDARDIZATION
COMITÉ EUROPÉEN DE NORMALISATION
EUROPÄISCHES KOMITEE FÜR NORMUNG

CEN-CENELEC Management Centre: Avenue Marnix 17, B-1000 Brussels

Foreword

This document (EN ISO 14555:2014) has been prepared by Technical Committee ISO/TC 44 "Welding and allied processes" in collaboration with Technical Committee CEN/TC 121 "Welding and allied processes" the secretariat of which is held by DIN.

This European Standard shall be given the status of a national standard, either by publication of an identical text or by endorsement, at the latest by October 2014, and conflicting national standards shall be withdrawn at the latest by October 2014.

Attention is drawn to the possibility that some of the elements of this document may be the subject of patent rights. CEN [and/or CENELEC] shall not be held responsible for identifying any or all such patent rights.

This document supersedes EN ISO 14555:2006.

According to the CEN-CENELEC Internal Regulations, the national standards organizations of the following countries are bound to implement this European Standard: Austria, Belgium, Bulgaria, Croatia, Cyprus, Czech Republic, Denmark, Estonia, Finland, Former Yugoslav Republic of Macedonia, France, Germany, Greece, Hungary, Iceland, Ireland, Italy, Latvia, Lithuania, Luxembourg, Malta, Netherlands, Norway, Poland, Portugal, Romania, Slovakia, Slovenia, Spain, Sweden, Switzerland, Turkey and the United Kingdom.

Endorsement notice

The text of ISO 14555:2014 has been approved by CEN as EN ISO 14555:2014 without any modification.

| Contents | Page |
|---|-------------|
| Foreword..... | v |
| Introduction..... | vi |
| 1 Scope | 1 |
| 2 Normative references | 1 |
| 3 Terms and definitions | 2 |
| 4 Symbols and abbreviated terms | 4 |
| 4.1 Symbols | 4 |
| 4.2 Abbreviated terms | 4 |
| 5 Technical review | 5 |
| 6 Welding personnel | 5 |
| 6.1 Stud-welding operators | 5 |
| 6.2 Welding coordination | 6 |
| 7 Equipment | 6 |
| 7.1 Production equipment | 6 |
| 7.2 Description of the equipment | 6 |
| 7.3 Maintenance | 7 |
| 8 Production planning | 7 |
| 9 Welding procedure specification (WPS) | 7 |
| 9.1 General | 7 |
| 9.2 Information related to the manufacturer | 7 |
| 9.3 Information related to the parent material | 8 |
| 9.4 Welding process | 8 |
| 9.5 Joint | 8 |
| 9.6 Auxiliaries | 9 |
| 9.7 Power source | 9 |
| 9.8 Movable fixtures | 9 |
| 9.9 Welding variables | 10 |
| 9.10 Thermal conditions | 10 |
| 9.11 Post-weld heat-treatment | 10 |
| 9.12 Non-thermal treatment after welding | 10 |
| 10 Welding procedure qualification | 11 |
| 10.1 Principles | 11 |
| 10.2 Welding procedure tests | 11 |
| 10.3 Pre-production tests | 15 |
| 10.4 Previous experience | 15 |
| 10.5 Welding procedure qualification record (WPQR) | 15 |
| 11 Examination and testing | 16 |
| 11.1 General | 16 |
| 11.2 Visual examination | 16 |
| 11.3 Bend testing | 16 |
| 11.4 Tensile testing | 20 |
| 11.5 Torque test | 23 |
| 11.6 Macro examination | 23 |
| 11.7 Radiographic examination | 24 |
| 11.8 Ring test | 24 |

| | | |
|--------------|--|----|
| 12 | Acceptance criteria | 24 |
| 12.1 | General | 24 |
| 12.2 | Acceptance criteria for visual examination | 24 |
| 12.3 | Acceptance criteria for bend testing | 25 |
| 12.4 | Acceptance criteria for tensile testing | 25 |
| 12.5 | Acceptance criteria for torque testing | 25 |
| 12.6 | Acceptance criteria for macro examination | 25 |
| 12.7 | Acceptance criteria for radiographic examination | 25 |
| 12.8 | Acceptance criteria for ring tests | 25 |
| 12.9 | Acceptance criteria for additional tests | 26 |
| 13 | Workmanship | 26 |
| 14 | Process control | 26 |
| 14.1 | General | 26 |
| 14.2 | Production test | 27 |
| 14.3 | Simplified production test | 27 |
| 14.4 | Re-testing for production test or simplified production test | 28 |
| 14.5 | Production surveillance | 28 |
| 14.6 | Production surveillance record | 28 |
| 14.7 | Non-conformance and corrective actions | 29 |
| 14.8 | Calibration of the measuring and testing equipment | 29 |
| Annex A | (informative) Processing of stud welding | 30 |
| Annex B | (normative) Quality requirements for stud welding | 50 |
| Annex C | (informative) Manufacturer's welding procedure specification (WPS) | 51 |
| Annex D | (informative) Welding procedure qualification record form (WPQR) (for drawn-arc stud welding with ceramic ferrule or shielding gas and short-cycle drawn-arc stud welding) | 53 |
| Annex E | (informative) Welding procedure qualification record form (WPQR) (for capacitor discharge stud welding with tip ignition and capacitor discharge drawn-arc stud welding) | 58 |
| Annex F | (informative) Test results — Production test (for drawn-arc stud welding with ceramic ferrule or shielding gas and short-cycle drawn-arc stud welding) | 62 |
| Annex G | (informative) Test results — Production test (for capacitor discharge stud welding with tip ignition and capacitor discharge drawn-arc stud welding) | 65 |
| Annex H | (informative) Example of production surveillance record | 68 |
| Bibliography | | 69 |

Foreword

ISO (the International Organization for Standardization) is a worldwide federation of national standards bodies (ISO member bodies). The work of preparing International Standards is normally carried out through ISO technical committees. Each member body interested in a subject for which a technical committee has been established has the right to be represented on that committee. International organizations, governmental and non-governmental, in liaison with ISO, also take part in the work. ISO collaborates closely with the International Electrotechnical Commission (IEC) on all matters of electrotechnical standardization.

The procedures used to develop this document and those intended for its further maintenance are described in the ISO/IEC Directives, Part 1. In particular the different approval criteria needed for the different types of ISO documents should be noted. This document was drafted in accordance with the editorial rules of the ISO/IEC Directives, Part 2 (see www.iso.org/directives).

Attention is drawn to the possibility that some of the elements of this document may be the subject of patent rights. ISO shall not be held responsible for identifying any or all such patent rights. Details of any patent rights identified during the development of the document will be in the Introduction and/or on the ISO list of patent declarations received (see www.iso.org/patents).

Any trade name used in this document is information given for the convenience of users and does not constitute an endorsement.

For an explanation on the meaning of ISO specific terms and expressions related to conformity assessment, as well as information about ISO's adherence to the WTO principles in the Technical Barriers to Trade (TBT) see the following URL: [Foreword - Supplementary information](#)

The committee responsible for this document is ISO/TC 44, *Welding and allied processes*, Subcommittee SC 10, *Unification of requirements in the field of metal welding*.

This third edition cancels and replaces the second edition (ISO 14555:2006), which has been technically revised.

This corrected version of ISO 14555:2014 incorporates the following corrections:

- 9.5.6 was renumbered 9.6; consequently, subclauses 9.7 to 9.12 were also renumbered;
- in 11.1, "The methods described in 11.2 to 11.7 may be used ..." was replaced with "The methods described in 11.2 to 11.8 may be used ...";
- in Table A.6, No. 5, the incorrect figure was replaced with the correct one;
- in Annex C, " yes no" was replaced with " yes no".

Introduction

The purpose of arc stud welding is to weld predominantly pin-shaped metal parts to metal workpieces. In this International Standard it is referred to simply as stud welding. Amongst other things, stud welding is used in bridge building (especially in composite structures), steel structures, shipbuilding, facade-wall fabrication, vehicle manufacture, equipment design, steam-boiler construction, and the manufacture of household appliances.

The quality of a stud weld depends not only on strict compliance with the welding procedure specification but also on the correct function of the actuating mechanism (e.g. welding guns), and on the condition of the components, of the accessories and of the power supply.

This International Standard does not invalidate former specifications, providing the technical requirements are equivalent and satisfied.

Welding — Arc stud welding of metallic materials

1 Scope

This International Standard covers arc stud welding of metallic materials subject to static and fatigue loading. It specifies requirements that are particular to stud welding, in relation to welding knowledge, quality requirements, welding procedure specification, welding procedure qualification, qualification testing of operators and testing of production welds.

This International Standard is appropriate where it is necessary to demonstrate the capability of a manufacturer to produce welded construction of a specified quality.

NOTE General quality requirements for fusion welding of metallic materials are given in ISO 3834-1, ISO 3834-2, ISO 3834-3, ISO 3834-4 and ISO 3834-5.

This International Standard has been prepared in a comprehensive manner, with a view to it being used as a reference in contracts. The requirements contained within it can be adopted in full, or partially, if certain requirements are not relevant to a particular construction (see Annex B).

2 Normative references

The following referenced documents are indispensable for the application of this document. For dated references, only the edition cited applies. For undated references, the latest edition of the referenced document (including any amendments) applies.

ISO 857-1, *Welding and allied processes — Vocabulary — Part 1: Metal welding processes*

ISO 3834-1, *Quality requirements for fusion welding of metallic materials — Part 1: Criteria for the selection of the appropriate level of quality requirements*

ISO 3834-2, *Quality requirements for fusion welding of metallic materials — Part 2: Comprehensive quality requirements*

ISO 3834-3, *Quality requirements for fusion welding of metallic materials — Part 3: Standard quality requirements*

ISO 3834-4, *Quality requirements for fusion welding of metallic materials — Part 4: Elementary quality requirements*

ISO 4063, *Welding and allied processes — Nomenclature of processes and reference numbers*

ISO 6947, *Welding and allied processes — Welding positions*

ISO 9606-1, *Approval testing of welders — Fusion welding — Part 1: Steels*

ISO 9606-2, *Qualification test of welders — Fusion welding — Part 2: Aluminium and aluminium alloys*

ISO 13918:2008, *Welding — Studs and ceramic ferrules for arc stud welding*

ISO 14175, *Welding consumables — Shielding gases for arc welding and cutting*

ISO 14731, *Welding coordination — Tasks and responsibilities*

ISO 14732:1998, *Welding personnel — Approval testing of welding operators for fusion welding and of resistance weld setters for fully mechanized and automatic welding of metallic materials*

ISO 15607:2003, *Specification and qualification of welding procedures for metallic materials — General rules*

ISO/TR 15608, *Welding — Guidelines for a metallic materials grouping system*

ISO 15611, *Specification and qualification of welding procedures for metallic materials — Qualification based on previous welding experience*

ISO 15613, *Specification and qualification of welding procedures for metallic materials — Qualification based on pre-production welding test*

ISO 15614-1:2004, *Specification and qualification of welding procedures for metallic materials — Welding procedure test — Part 1: Arc and gas welding of steels and arc welding of nickel and nickel alloys*

ISO 15614-2, *Specification and qualification of welding procedures for metallic materials — Welding procedure test — Part 2: Arc welding of aluminium and its alloys*

ISO 17636-1, *Non-destructive testing of welds — Radiographic testing — X- and gamma-ray techniques with film*

ISO 17636-2, *Non-destructive testing of welds — Radiographic testing — X- and gamma-ray techniques with digital detectors*

ISO 17662, *Welding — Calibration, verification and validation of equipment used for welding, including ancillary activities*

3 Terms and definitions

For the purposes of this document, the terms and definitions given in ISO 857-1, ISO 3834-1, ISO 4063, ISO 14731, ISO 14732 and ISO 15607 and the following apply.

3.1 stud

fastener to be attached by stud welding

3.2 auxiliaries

ceramic ferrules and shielding gases

3.3 stud-welding operator

operating personnel for stud-welding equipment

Note to entry In special cases (e.g. mass production at the manufacturer's factory) the welding can be carried out by suitable auxiliary personnel, appropriately trained and supervised.

3.4 stud diameter

d
stud nominal diameter

Note 1 to entry See ISO 13918.

3.5

welding diameter

d_w

diameter at the weld base

3.6

weld zone

welded area underneath the welding diameter

3.7

current intensity

root-mean-square (RMS) value of the welding current in the steady state during the burning time of the arc

Note to entry Current intensity is not applicable to capacitor discharge.

3.8

welding time

time difference between the ignition and the final extinction of the main arc

3.9

lift

L

distance between the stud tip and the work piece surface with the stud-lifting mechanism in position and activated

Note 1 to entry For tip ignition, this definition applies to the ignition gap.

Note 2 to entry See Figure A.1.

3.10

plunge

axial movement of the stud towards the surface of the work piece

3.11

protrusion

P

(unregulated lifting mechanism) distance between the tip of the stud and the face of the support device in their initial positions, where the support device faces the work piece

Note 1 to entry A spring-loaded lifting mechanism is an unregulated lifting mechanism.

Note 2 to entry See Figure A.1.

3.12

arc blow

magnetic deflection of the arc from the axial direction of the stud

3.13

flux

aluminium additive on the weld end of the stud, which improves the ignition and de-oxidizes the weld pool

3.14

dual-material stud

two-material stud composed of a material at the weld tip, similar to that of the parent material, and a dissimilar material outside the weld tip, which are joined by a friction weld, thus avoiding a mixed structure in the weld zone when stud welding

3.15

structure subjected to fatigue loading

structure subject to a set of typical load events described by the positions or movements of loads, their variation in intensity and their frequency and sequence of occurrence

3.16

through-deck stud-welding

application where shear connectors are welded to a steel structure through thin steel sheet with a thickness of less than 3 mm

4 Symbols and abbreviated terms

4.1 Symbols

For the purposes of this document, the following symbols apply.

| | |
|----------|--|
| C | capacitance (expressed in mF) |
| d | stud diameter (expressed in mm) |
| d_w | welding diameter (expressed in mm) |
| h | length of the threaded part of the nut |
| I | current intensity (expressed in A) |
| L | lift |
| P | protrusion |
| t | thickness of plate |
| t_w | welding time (expressed in ms or s) |
| T | torque (expressed in Nm) |
| U | charging voltage (expressed in V) |
| E | charging energy (expressed in Ws) |
| α | bending angle (expressed in °) |

4.2 Abbreviated terms

For the purposes of this document, the following abbreviated terms apply.

| | |
|------|---|
| CF | ceramic ferrule |
| HAZ | heat-affected zone |
| NP | no protection |
| PA | flat welding position |
| PC | horizontal welding position |
| PE | overhead welding position |
| pWPS | preliminary welding procedure specification |
| SG | shielding gas |
| WPS | welding procedure specification |
| WPQR | welding procedure qualification record |

5 Technical review

When a technical review is required by an application standard, by specification or by use of ISO 3834-2, ISO 3834-3 or ISO 3834-4, the manufacturer shall check, as appropriate, the following aspects:

- a) the accessibility and welding position of the stud weld;
- b) the nature of the surface and the collar shape of the welded joint;
- c) materials and combinations of materials (see Tables A.3 and A.4); including decking material where the through-deck technique is being proposed;
- d) the ratio of stud diameter to parent metal thickness (avoidance of damage on the reverse side of the parent metal);
- e) dimensions and details of the weld preparation and of the finished weld, including the nature of the stud and parent -metal surfaces, positional and angular accuracy and the length tolerance of the welded stud;
- f) the use of special techniques to avoid damage to the reverse side of the parent metal;
- g) techniques to assure the angular position of the welded stud.

NOTE Consideration is paid to the multi-axial stress state arising from localized heating/cooling. This stress concentration reduces the fatigue strength of a component with welded studs.

6 Welding personnel

6.1 Stud-welding operators

The qualification can be done by a welding procedure test (see 10.2) or a pre-production test (see 10.3) and shall include testing in accordance with the acceptance criteria specified in 12, if relevant.

Stud-welding operators shall have appropriate knowledge to operate the equipment, to adjust it properly, to carry out the welding correctly and, while doing so, to pay attention to good contact and suitable connection between the work piece cables and uniform distribution of ferromagnetic materials (see Table A.8).

The welding personnel shall be qualified in accordance with ISO 14732.

The qualified operator shall be deemed to be qualified for any stud welding equipment with the same mode of selecting the parameters which was used in the qualification test. Change in the welding process variant (numbers 783, 784, 785, 786 of ISO 4063) requires a new qualification.

A test of job knowledge is required for all qualification methods. This test shall cover, as a minimum:

- a) setting up the welding equipment in accordance with the welding procedure specification;
- b) basic knowledge of the way in which suitable connection of work piece cables, the polarity of the stud, and arc blowing can influence the weld result (see Table A.8);
- c) basic assessment of the welded joint for imperfections (see Tables A.5, A.6 and A.7);
- d) safe execution of the welding operations, i.e. good contact of the stud in the stud holder, no movement during the welding process, operation checking and correct positioning of the welding gun).

6.2 Welding coordination

Welding coordination shall be performed in accordance with ISO 14731. Refer to Annex B for quality level according ISO 3834 for the welding coordinator.

Welding coordination personnel for stud welding shall have knowledge of and experience in the relevant stud-welding process, and shall be able to select and set the correct parameters, e.g. lift, protrusion (plunge), current intensity, and welding time.

A welding coordinator is not required for stud welding to structures subjected to unspecified static loading (see Annex B).

7 Equipment

7.1 Production equipment

Suitable stud-welding equipment shall be used, with power supplies of sufficient capacity to weld the stud properly to the parent material when the equipment is correctly set up. The following equipment shall be available, as required:

- a) power sources, control unit and movable fixtures;
- b) cables with sufficient cross-section, solid connection terminals and sufficient earth connection;
- c) handling equipment for the technical aspects of welding fabrication (jigs, fixtures);
- d) weld data monitoring equipment;
- e) cleaning facilities for contact points and welding points;
- f) measuring and testing equipment;
- g) equipment for pre- and post-treatment;
- h) equipment and welding plant for retouching.

7.2 Description of the equipment

A list of the stud-welding equipment shall be maintained, which shall serve as evidence of the performance and stud-welding application field. It shall include:

- a) details of the smallest and largest weldable stud diameter;
- b) the maximum number of studs to be welded per unit of time;
- c) the regulating range of the power supply;
- d) the mode of operation and performance of mechanized or automatic stud-welding equipment;
- e) details of the available test equipment.

7.3 Maintenance

The correct functioning of the equipment shall be ensured. During production, a function check of the actuation mechanisms shall be performed at fixed intervals. Cables, terminals, stud and ceramic ferrule holders shall be regularly checked and replaced at the appropriate time. For mass production and comprehensive quality requirements in accordance with ISO 3834-2, a maintenance plan for additional essential systems shall be drawn up. Examples of such systems are:

- a) stud sorting and feeding systems;
- b) stud and ceramic ferrule holders;
- c) mechanical guides and fixtures;
- d) measuring equipment;
- e) cables, hoses, connecting elements;
- f) a monitoring system.

8 Production planning

For stud welding, the production planning shall also contain the following elements:

- a) a definition of the required stud-welding procedures and equipment;
- b) details of which jigs and fixtures are used;
- c) the surface preparation method.

9 Welding procedure specification (WPS)

9.1 General

The welding procedure specification (WPS) shall give details of how a welding operation shall be performed and shall contain all relevant information about the welding work.

Information listed in 9.2 to 9.13 is adequate for most welding operations. For some applications, it may be necessary to supplement or reduce the list. The relevant information shall be specified in the WPS.

Ranges and tolerances shall be specified when appropriate. An example of the WPS format is given in Annex C.

9.2 Information related to the manufacturer

9.2.1 Identification of the manufacturer

— unambiguous identification.

9.2.2 Identification of the WPS

— alphanumeric designation (reference code).

9.2.3 Reference to the welding procedure qualification record (WPQR) or other relevant documents

- alphanumeric designation (reference code).

9.3 Information related to the parent material

9.3.1 Parent material type

- identification of material, preferably by reference to an appropriate standard;
- parent material(s) delivery condition;
- identification of coating or any other surface condition.

NOTE A WPS can cover a material group in accordance with ISO/TR 15608. See also ISO/TR 20172, ISO/TR 20173 and ISO/TR 20174.

9.3.2 Dimensions

- the thickness or range of thicknesses of the parent material;
- other relevant dimensions (e.g. thickness and configuration of the steel sheet for through-deck applications).

9.4 Welding process

- designation in accordance with ISO 4063.

9.5 Joint

9.5.1 Joint design

- sketch of the joint design showing the relative positions of studs and tolerances;
- the sequence of the welding of studs shall be indicated on the sketch if essential for application.

9.5.2 Welding position

- welding positions shall be specified in accordance with ISO 6947.

9.5.3 Preparation of parent material surface

- method of surface preparation, if necessary (e.g. cleaning, degreasing, pickling);
- maximum time permitted between preparation and welding (if required).

9.5.4 Jigs and fixtures

- the methods to be used (if required);
- fixture details, templates, etc.

9.5.5 Support

- the method of support;
- specification of supporting material;
- dimensions of support (when welding thin plates).

9.6 Studs

9.6.1 Designation

- designation according to standard, supplier or trade name; non-standard studs shall be specified.

9.6.2 Handling

- if the studs are to be treated (e.g. by cleaning) before use, this shall be specified.

9.7 Auxiliaries

9.7.1 Ceramic ferrules (if any)

- designation according to standard, supplier or trade name; non-standard ceramic ferrules shall be specified;
- ceramic ferrules shall be stored in a clean and dry environment.

9.7.2 Protective gas (if any)

- designation in accordance with ISO 14175.

9.8 Power source

- manufacturer, type.

9.9 Movable fixtures

9.9.1 Welding gun/lift mechanism

- manufacturer, type;
- damper.

9.9.2 Shielding gas system (if used)

- gas flow rate;
- (schematic) description showing nozzle dimensions and position of nozzle(s) in relation to stud and work piece.

9.9.3 Stud feeding system (if any)

- description of stud feeding system including sketch.

9.10 Welding variables

9.10.1 Drawn arc stud welding with ceramic ferrule or shielding gas and short-cycle drawn arc stud welding

- a) polarity;
- b) welding current;
- c) welding time;
- d) lift;
- e) protrusion;
- f) damper;
- g) number and position of earth clamps.

9.10.2 Capacitor discharge drawn arc stud welding or capacitor discharge stud welding with tip ignition

- a) polarity;
- b) capacitance;
- c) charging voltage;
- d) spring force and/or gap length;
- e) number and position of earth clamps;
- f) welding cable configuration (if used for current control).

9.11 Thermal conditions

- a) preheat temperature (if required);
- b) if preheating is not required, the lowest permitted ambient temperature.

9.12 Post-weld heat-treatment

If, in special cases, any post-weld heat-treatment or ageing is necessary, specification of the procedure or reference to a separate post-weld heat-treatment or ageing specification is required. This should include specification of the entire thermal cycle.

9.13 Non-thermal treatment after welding

- a) grinding, machining or any other mechanical treatment;
- b) pickling or any other chemical treatment;
- c) any special procedure for removal of ferrules.

10 Welding procedure qualification

10.1 Principles

Preliminary welding procedure specifications (pWPS) for arc stud welding shall be prepared in accordance with Clause 9 and qualified prior to production, whenever required. They shall specify the range for all the relevant parameters. In principle, the following methods of qualification are permitted, but specification or application code requirements can restrict the choice of method:

- a) qualification by welding procedure test in accordance with 10.2;
- b) qualification by pre-production tests in accordance with 10.3;
- c) qualification based on previous experience in accordance with 10.4.

All new welding procedure qualifications are to be in accordance with this International Standard from the date of its issue. However, this International Standard does not invalidate previous welding procedure qualifications made to former national standards or specifications, providing the technical requirements are satisfied and the previous procedure qualifications are relevant to the application and production work on which they are to be employed. Previous procedure qualifications to former national standards or specifications should be considered at the time of the enquiry or contract stage and agreed between the contracting parties.

10.2 Welding procedure tests

10.2.1 Application

When welding procedure tests are required, these shall be carried out in accordance with the provisions in 10.2 of this International Standard, unless more severe tests are specified.

10.2.2 Proof of conformity of parent materials and stud materials

For the parent material and the stud material to be used, proof of conformity shall be available.

In the absence of such proof, the parent material and/or stud material shall be subjected to additional material tests before the welding procedure tests. For this purpose, sufficient amounts of parent material and stud material from the same melt as used in the test shall be made available.

10.2.3 Shape and dimensions of test pieces

The dimension of the test piece(s) shall be sufficient to carry out all tests. The thickness of the test pieces shall be chosen so that the plate or flange thickness proposed for production is covered (see 10.2.8.6).

10.2.4 Welding

Preparation, set-up and welding of test pieces shall be carried out in accordance with the pWPS, under the general conditions of production welding that they represent. The same welding positions shall be observed as on the actual work piece. There shall be sufficient distance from the lateral earth clamps to avoid arc blow.

Welding procedure tests shall be carried out on the smallest and largest stud diameters used in practice.

As a minimum, the numbers of studs indicated in Table 1 and Table 2 shall be welded in the welding procedure test.

10.2.5 Scope of examination and testing

The examination and testing includes non-destructive and destructive tests, which shall be in accordance with the requirements of Tables 1, 2 and 3.

All inspection and tests shall be performed in accordance with the procedures specified in Clause 11. The number and type of test stated in Tables 1, 2 and 3 shall only be used in the case of the qualification of a pWPS based on the use of stud material and parent material, as specified in Table A.3.

10.2.6 Acceptance criteria

The acceptance criteria described in Clause 12 shall be fulfilled unless otherwise specified.

Table 1 — Examination and testing of test pieces welded by drawn arc stud welding with ceramic ferrule or shielding gas

| Type of test | Number of studs to be tested | | | |
|--|---|---|--|--|
| | Application ≤ 100°C Comprehensive quality requirements acc. to ISO 3834-2 | | Application ≤ 100°C Standard quality requirements acc. to ISO 3834-3 | Application > 100 °C All quality requirements acc. to ISO 3834 |
| | $d_w \leq 12$ mm | $d_w > 12$ mm | All diameters (d_w) | All diameters (d_w) |
| Visual examination | all | | | |
| Bend testing [see Figures 2 a), 2 b) or 2 c)] | 10 (60° bending angle) | 5 (60° bending angle) | 10 (60° bending angle) | 5 (30° bending angle) |
| Bend testing by means of torque wrench (see Figure 3, applies to boiler pins only) | not applied | | | 10 |
| Tensile testing (see Figures 4, 5 or 6) | — | 5 | — | — |
| Radiographic examination | not applied | 5 (optional instead of tensile testing) | — | — |
| Macro examination (off-set 90° through the centre of the stud) | — | 2 | — | 2 ^a |

^a Only for welds on a tube subjected to pressure.

Table 2 — Examination and testing of test pieces welded by short-cycle drawn arc stud welding with $d_w \leq 12$ mm

| Type of test | Number of studs to be tested |
|--|------------------------------|
| Visual examination | All |
| Bend testing 60° [see Figures 2 a), 2 b) or 2 c)] | 10 |
| Torque test (see Figure 6) or macro examination (off-set 90° through the centre of the stud) | 10 (torque test) |
| | 2 (macro examination) |

Table 3 — Examination and testing of test pieces welded by capacitor discharge stud welding with tip ignition and capacitor discharge drawn arc stud welding

| Type of test | Number of studs to be tested |
|---|------------------------------|
| Visual examination | All |
| Tensile testing (see Figures 4 or 5) | 10 |
| Bend testing 30° [see Figures 2 a), 2 b) or 2 c)] | 20 |

10.2.7 Re-testing

If one of the studs fails to meet the requirements, two similar replacement studs can be taken from the associated test pieces. If this is not possible, equivalent studs shall be welded subsequently. It is therefore recommended that a sufficient number of replacement studs be provided for the welding procedure tests.

If more than one stud, or one of the two replacement studs, does not satisfy the requirements, the test has failed.

10.2.8 Range of qualification

10.2.8.1 General

All the conditions of validity stated below shall be met independently of each other. Changes outside of the ranges specified shall require a new welding procedure test.

There is no limit to the duration of the validity of the welding procedure qualification, provided that no quality changes are made and that a production surveillance record is kept in accordance with 14.6.

However, since the result of stud welding depends not only on compliance with the welding procedure specification, but also, for example, the skillness /experience of the operator is critical in terms of weld quality, a production test shall be carried out at least once a year, as specified in 14.2. Any stud with a diameter within the range of validity may be used for the production test.

In the event of production being suspended for more than one year, the validity of the welding procedure qualification shall be confirmed in a production test. Qualification according to 10.3.2 is valid until weld parameters, changes.

10.2.8.2 Conditions related to the manufacturer

The qualification of a pWPS obtained by a manufacturer is valid for welding in workshops or sites under the same technical and quality control of that manufacturer.

10.2.8.3 Conditions related to the welding process

The qualification is valid only for the welding process used in welding procedure test.

10.2.8.4 Conditions related to the welding parameters

The qualification is valid for changes of the welding parameters within the recommendations of the supplier of the welding equipment.

10.2.8.5 Conditions related to the parent material

A welding procedure test carried out with one of the steels of a material group, in accordance with ISO/TR 15608, covers the steels with lower specified yield strength of this material group, or the lower alloyed steels of the same material group for the intentional added elements, but not for fortuitous impurities. In accordance with

ISO/TR 15608, material group 8 or 10 cover material group 1 and material group 2, and vice versa, whilst material group 21 covers material group 22, and vice versa.

10.2.8.6 Stud material

Welding procedure tests cover all materials of the same material group in accordance with ISO/TR 15608 with the following addition:

- a) For drawn-arc stud-welding processes up to 13 mm diameter, material groups 8 or 10 cover material groups 1 and 2.1 and vice versa.
- b) For capacitor discharge stud-welding processes, material group 8 covers material groups 1 to 6 and 11.1 and vice versa.
- c) Material group 21 covers material group 22 and vice versa.

10.2.8.7 Parent material thickness

As recommended in Table A.1, the material thickness used for the welding procedure test applies to all thicknesses which exceed those specified in Table A.1, providing the pWPS used in the welding procedure test applies.

For material thicknesses below the recommended minimum thickness, a new welding procedure test is required.

10.2.8.8 Steel sheet thickness for through-deck applications

For through-deck stud-welding, qualification of the thickest steel sheet used in production qualifies all thinner steel sheets.

10.2.8.9 Conditions related to the stud cross-section and shape

A single welding procedure test covers all stud shapes, but only the welding cross-section used in the test.

Two welding procedure tests on different welding cross-sections cover the range between the two cross-sections and all stud shapes.

10.2.8.10 Conditions related to the welding position

Using drawn arc stud welding with ceramic ferrule or shielding gas and short-cycle drawn arc stud welding, welding position PC covers welding positions PE and PA, but not vice versa. For welding position PC, special ceramic ferrules can be used. Welding position PE covers welding position PA, but not vice versa. Welding positions refer to ISO 6947.

Through-deck stud welding shall be carried out in the PA position only.

Using capacitor discharge stud welding with tip ignition and capacitor discharge drawn arc stud welding, a welding procedure test carried out in any one welding position is valid for welding in all welding positions.

10.2.8.11 Conditions related to the welding equipment

If there is a change in the type of welding gun or head, and/or power source, or welding equipment manufacturer, the welding procedure specification shall be verified by a production test.

10.2.8.12 Preheating

Welding procedure specifications that have been qualified by a welding procedure test without preheating are also valid for those for welding with preheating, but not vice versa.

10.3 Pre-production tests

10.3.1 Pre-production test for workshop applications

The general provisions of ISO 15613 shall be adhered to, with the following additions and modifications:

- a) welding procedure specifications, pWPS and WPS, shall conform to the provisions of Clause 9;
- b) the actual production shall be controlled by a suitable scheme for process control;
- c) the number of studs (produced items) tested shall meet the requirements of 10.2.4, if possible;
- d) qualification is limited to the same type of equipment, the same type and thickness of the parent material and the same diameter of studs as used during the pre-production test.

10.3.2 Pre-production test for stud welding on site (for through-deck stud welding)

This test shall be carried out for building constructions with principally static loads. This test is applicable to an individual site under prevailing conditions.

- a) Welding procedure specifications, pWPS and WPS, shall conform to the provisions of Clause 9.
- b) A minimum of 10 studs shall be welded.
- c) Visual examination shall be carried out on all studs.
- d) Bend test (30°) shall be carried out on all studs.

The welding parameters and setup conditions on site shall be recorded in the WPQR (see Annex D) or in a test report according to Annex F. The influence of cable length, cable cross-section, environmental conditions shall be taken into account.

Welded studs that have been bend tested shall not be straightened after testing.

10.4 Previous experience

The general provisions of ISO 15611 shall be adhered to, with the following additions and modifications:

- a) welding procedure specifications, pWPS and WPS, shall conform to the provisions of Clause 9;
- b) the former production on which the experience is based shall have been controlled by a suitable scheme for process control, giving a statistical confidence compatible with the future application of the welding procedure to be qualified;
- c) qualification is limited to the same type of equipment, the same type and thickness of the parent material and the same diameter of studs as used during the production on which the experience is based.

The use of previous experience instead of welding procedure tests is not permitted for steel welds with standard or comprehensive quality requirements (see Annex B).

10.5 Welding procedure qualification record (WPQR)

The welding procedure qualification record (WPQR) is a statement of the results of assessing each test piece, including re-tests. The relevant items listed for the WPS in Clause 9 shall be included, together with details of any features that would be rejected on the basis of the requirements in Clause 11. If no rejectable features or unacceptable test results are found, a WPQR detailing the welding procedure test piece results is qualified, and shall be signed and dated by the examiner or test body.

A WPQR format, as shown in Annex D or Annex E, may be used to record details for the welding procedure and the test results, in order to facilitate uniform presentation and assessment of the data.

11 Examination and testing

11.1 General

The methods described in 11.2 to 11.8 may be used for examination and testing of stud welds. Tests shall be selected according to the application.

In certain stud-welding applications, e.g. steam boilers, shipbuilding or nuclear industry, additional tests (e.g. hardness tests or ultrasonic examinations) may be required by application standards or specifications.

11.2 Visual examination

For drawn-arc stud welding with ceramic ferrule or shielding gas and short-cycle drawn arc stud welding, visual examination is used for assessing the following, as appropriate for the application:

- a) the uniformity of the shape of the weld collar, its size and its colour (guidance values for drawn arc stud welding with ceramic ferrule are given in ISO 13918), and
- b) location, length and angle of the stud after welding.

For capacitor discharge drawn arc stud welding and capacitor discharge stud welding with tip ignition, visual examination is used for assessing the uniformity of the spatter ring.

11.3 Bend testing

The test serves as a simple bench test for approximate checking of the chosen welding data. In the test, the weld is subjected to bending in an undefined manner. If arc blow or another visible imperfection is suspected, the stud shall be bent in a manner such that the area to be examined is in the tension zone. This can be done by one of the two following methods. Shear connectors that have been bent shall not be straightened. If the bending angle does not exceed 30 ° the shear capacity is not significantly reduced.

- a) The studs are bent by 60° using drawn arc stud welding with ceramic ferrule or shielding gas and applications ≤ 100 °C, or short-cycle drawn arc stud welding, by 30° using capacitor discharge stud welding with tip ignition or capacitor discharge drawn arc stud welding or drawn arc stud welding with ceramic ferrule or shielding gas and applications > 100 °C (see Figure 2). In the case of studs with rectangular base the bending shall be performed over the weak axis. In the case of double-ended studs (e.g. Y-anchors) both arms shall be subjected to the specified bend angle but into different directions (see Figure 1).

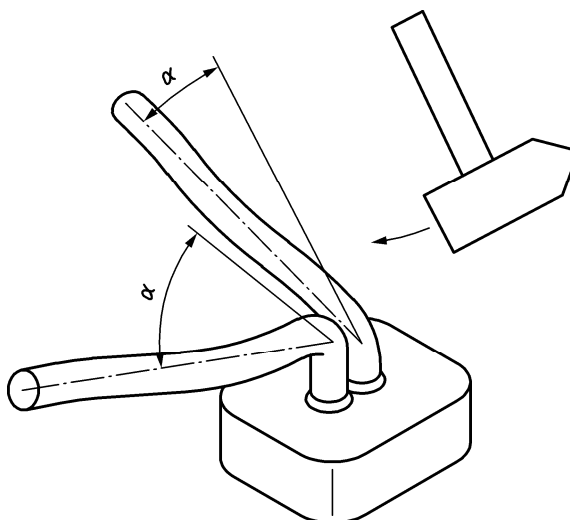
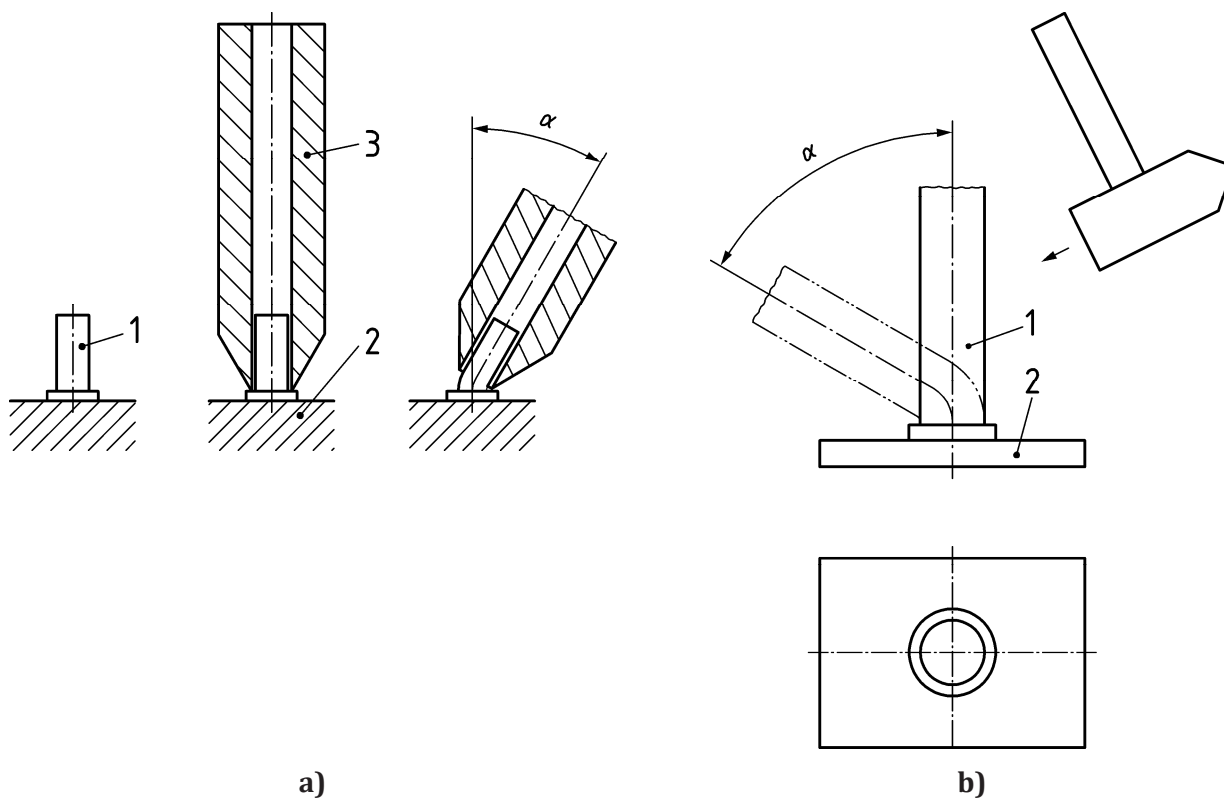
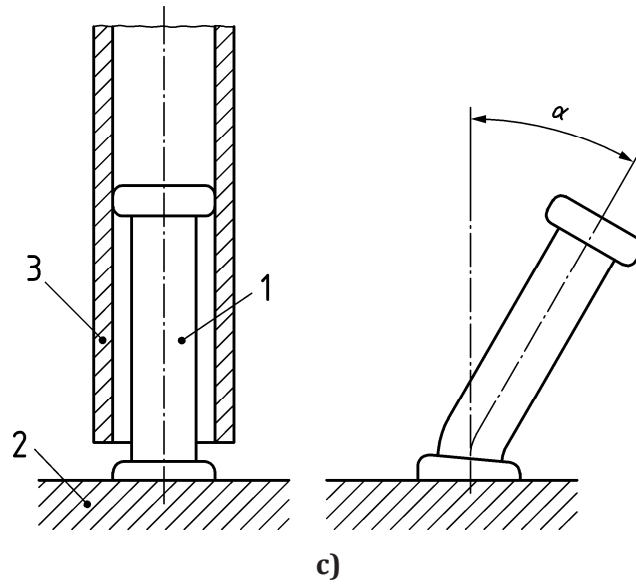

Figure 1 — Bending of the arms of a double ended stud

b) The studs are stressed by applying a bending moment below the elastic limit (see Figure 1).

NOTE Values of bending moments for boiler pins by applications > 100 °C are given in Table 4.





Key

- 1 stud
- 2 work piece
- 3 tool
- α bending angle

Figure 2 — Examples of bend testing

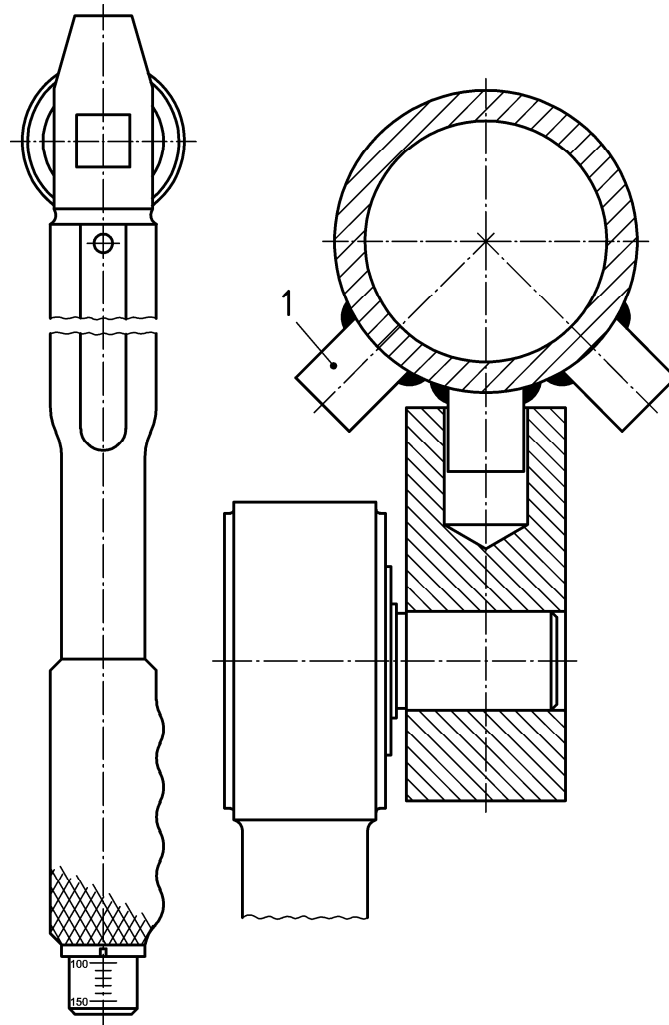

a) Torque wrench for bend testing

Key

1 stud

Figure 3 — Example of bend testing by means of torque wrench

Dimensions in millimetres

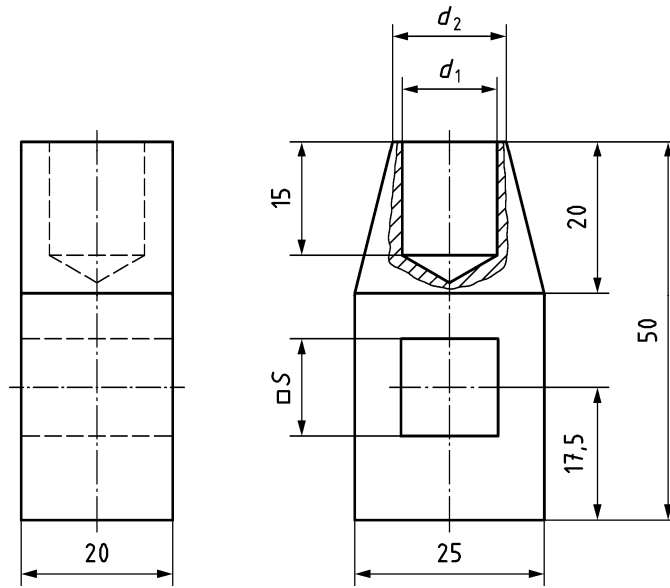

b) Test tool for bend testing

Key

d_1 stud diameter + 0,3 mm

d_2 tool diameter

S drive dimension

NOTE 1 The tool diameter can be chosen freely by the manufacturer, depending on the stud spacing.

NOTE 2 The drive dimension depends on the tool

Figure 3 — Example of bend testing by means of torque wrench (continued)

Table 4 — Bending moments based on stud diameter (applies to boiler pins only)

| Stud diameter d mm | Bending moment Nm |
|----------------------------|----------------------|
| 8 | 40 |
| 10 | 60 |
| 12 | 85 |

The acceptance criteria given in 12.3 shall be fulfilled unless otherwise specified.

11.4 Tensile testing

By using a suitable tension device (see Figures 4 and 5) the welded studs are pulled axially until fracture. The test only applies to studs by application ≤ 100 °C.

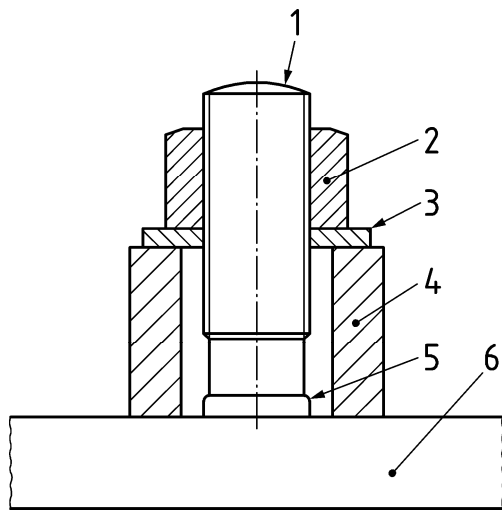

a)

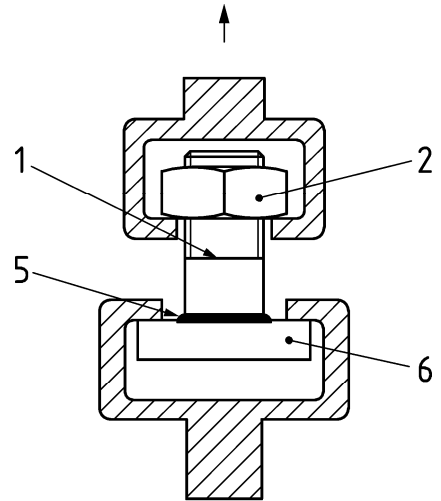

b)

Key

- 1 stud
- 2 steel nut
- 3 washer
- 4 sleeve
- 5 collar
- 6 work piece

Figure 4 — Examples of tensile testing of threaded studs

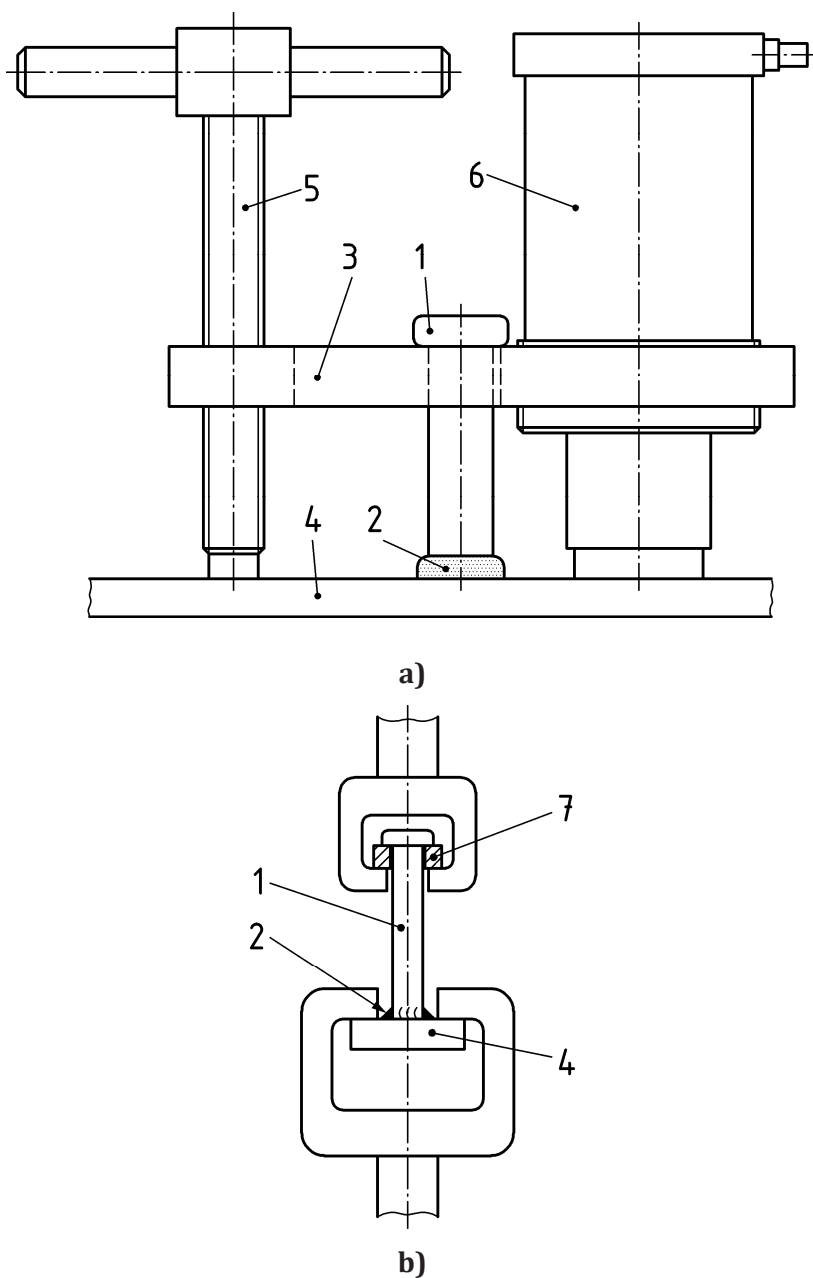

Key

- 1 stud (shear connector)
- 2 collar
- 3 bridge
- 4 work piece
- 5 screw for levelling
- 6 hydraulic cylinder
- 7 washer

NOTE The washer is required for hardness 40 to 55 HRC.

Figure 5 — Examples for tensile testing of shear connectors

11.5 Torque test

Weld resistance is checked by applying a torque T on a cap nut fully tightened on the stud (see Figure 6).

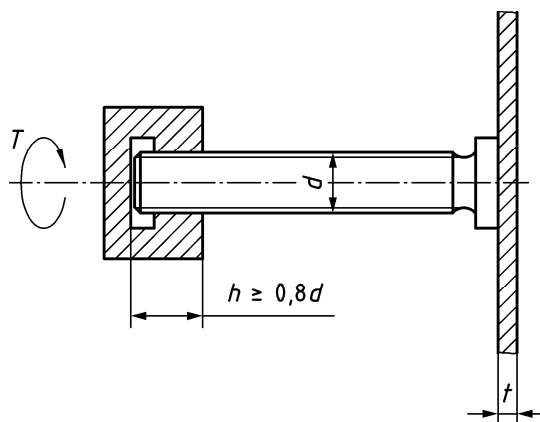

Key

- d stud diameter
- h length of the threaded part of the nut
- t thickness of plate
- T torque

NOTE Minimum values of the required torque on mild steel are given in Table 5.

Figure 6 — Example of torque test

Table 5 — Minimum values of required torque on mild steel

| Minimum thickness of the plate t mm | Stud diameter d | Torque T Nm |
|---|----------------------|---------------------|
| 0,7 | M3 | 1,2 |
| | M4 | 3 |
| | M5 | 6 |
| | M6 | 9 |
| 1,5 | M8 | 24 |
| | M10 | 46 |
| | M12 | 80 |

11.6 Macro examination

The macro examination serves to check the shape and depth of the penetration as well as imperfections. The assessment shall be carried out with a maximum of tenfold magnification.

Macro examination is only required for the welding processes, drawn arc stud welding with ceramic ferrule or shielding gas, and short-cycle drawn arc stud welding. For the specimen, a stud which has passed the bend test may be chosen.

11.7 Radiographic examination

The radiographic examination serves to check the weld area for internal imperfections. Radiographic examination is only required for the welding process, drawn arc stud welding with ceramic ferrule or shielding gas $d > 12$ mm for applications ≤ 100 °C, when tensile tests are not carried out.

The studs shall be cut off just over the collars.

Radiography shall be carried out in accordance with ISO 17636, using class B technique. The imperfections shall be in accordance with limits specified in 12.1.

11.8 Ring test

The ring test serves as a production test for shear connectors principally subject to static loads in building constructions. The ring test is only permitted for studs welded under the qualification in accordance with 10.3.2.

The head of the shear connector is tapped with a hammer with a mass of 0,9 kg to 2 kg. The angle of swing shall be between 20° and 30° and shall be allowed to free fall.

NOTE The execution and the assessment of the ring test needs sufficient experience.

12 Acceptance criteria

12.1 General

The weld zones of the studs shall be free of imperfections, except those which are to be accepted by the different tests and examinations.

The acceptance criteria shall be in accordance with 12.2 to 12.8, unless otherwise specified in application standards or specifications.

If elementary quality requirements are required in accordance with ISO 3834-4, the limit of the imperfections shall be specified.

If comprehensive quality requirements are required in accordance with ISO 3834-2, the total area of all imperfections shall not exceed 5 % of the area of the weld zone.

If standard quality requirements are required in accordance with ISO 3834-3, the total area of all imperfections shall not exceed 10 % of the area of the weld zone.

12.2 Acceptance criteria for visual examination

For drawn arc stud welding with ceramic ferrule or shielding gas, and short-cycle drawn arc stud welding, the imperfections shown in Table A.5, Nos. 2 to 5, and the imperfections shown in Table A.6, Nos. 2 and 5, are not acceptable.

For capacitor discharge drawn arc stud welding and capacitor discharge stud welding with tip ignition, the imperfections shown in Table A.7, Nos. 2 to 4, are not acceptable.

12.3 Acceptance criteria for bend testing

A weld passes the test if no cracks are found in the weld after bending of the stud to the required angle.

If a low-deformation fracture occurs in the heat-affected zone, the weldability of the materials shall be checked (e.g. tendency to hardening).

If inhomogeneous deformation has to be expected due to the geometry of the stud, e.g. for studs with reduced base, or if a bend until the mentioned angle is not possible, e.g. for studs of short length in relation to diameter, for two-material studs and for studs with yield strength above 355 N/mm^2 , the suitability of the weld shall be shown by other means. A sufficient plastic deformability shall be achieved.

12.4 Acceptance criteria for tensile testing

A fracture in the weld area is not permitted, if comprehensive quality requirements in accordance with ISO 3834-2 are required.

If standard quality requirements in accordance with ISO 3834-3 are required, fractures within the weld zone are only permitted if the nominal tensile strength of the stud material is reached. Imperfections in the fracture surface shall be in accordance with the limits specified in 12.1.

By use of flanged studs according to ISO 13918 and the welding processes, capacitor discharge drawn arc stud welding or capacitor discharge stud welding with tip ignition fractures within the weld zone are permitted, if the non-welded area does not exceed 35 % of the flanged area and the nominal tensile strength of the stud material is reached.

In the procedure test for drawn arc stud welding a shear failure of the parent metal is not permitted. Therefore a sufficient thickness of the test piece is recommended.

NOTE An insufficient weld quality would not be detected in case a thin parent metal would fail in shear failure.

12.5 Acceptance criteria for torque testing

The required torque shall be reached without weld failure.

12.6 Acceptance criteria for macro examination

The total length of all visible imperfections shall not exceed 20 % of the welding diameter. An undercut of an extent not larger than 5 % of the welding diameter is permissible, provided it appears at one side of the macro section only and the bend test which has been carried out in the same test procedure has been passed. Imperfections with an extent $\leq 0,5 \text{ mm}$ are disregarded provided there is a distance of at least 0,5 mm between the particular imperfections.

In the case of applications $> 100 \text{ }^\circ\text{C}$, a sufficient weld between stud and tube material (subjected to pressure) has to be achieved whilst leaving a minimum of 2 mm wall thickness non molten in the tube. In the case of undershooting this value, the actual conditions shall be proven by calculation.

12.7 Acceptance criteria for radiographic examination

Imperfections with dimensions larger than specified in 12.1 are not acceptable.

12.8 Acceptance criteria for ring tests

A clear resonating ring would typically indicate acceptable fusion characteristics, whereas a dull sound would indicate possible fusion imperfections.

12.9 Acceptance criteria for additional tests

Acceptance criteria for additional tests shall be specified. For the assessment, the characteristics of the stud-welding process shall be taken into account.

EXAMPLE For the hardness test, higher hardness values than those specified in ISO 15614-1:2004, Table 2, are permitted.

13 Workmanship

Surfaces to be welded shall be maintained dry and free from condensation. When a rapid cooling rate is anticipated, appropriate preheating may be necessary.

Depending on the welding process, ceramic ferrules and/or shielding gases are used for protection or to concentrate the arc. The ceramic ferrules shall be correctly chosen for the stud diameter and the type of stud. The following points shall be observed:

- a) the ceramic ferrules shall be stored in a dry place;
- b) ceramic ferrules which had become wet shall not be used;
- c) the ceramic ferrule shall be pressed against the parent material;
- d) the ceramic ferrule shall fit centrally with respect to the stud.

NOTE Tilting or uneven contact of the ceramic ferrule at the stud leads to an uneven collar and can inhibit plunging.

In special cases (drawn-arc stud welding of aluminium and its alloys or CrNi steels) it may be necessary to use shielding gases. In principle, the ceramic ferrule can be replaced by shielding gas (for restrictions, see Table A.1). The gas is fed to a device that shall ensure uniform gas shielding without turbulence. Note also the following points:

- the gas feed should be sealed off on the stud side;
- the gas shall displace the atmosphere before welding starts, so a defined pre-flow time shall be observed;
- in the case of aluminium, particularly careful gas shielding is essential.

14 Process control

14.1 General

For quality assurance, various quality requirements shall be met, depending on the stud-welding process and the field of application (see Annex B). Before, during and after production, tests shall therefore be performed. The various tests are as follows:

- a) production test;
- b) simplified production test;
- c) production surveillance.

These tests can be carried out by using the actual production pieces or by using special test pieces. The pieces shall correspond to the production conditions.

14.2 Production test

14.2.1 General

Production tests shall be performed by the manufacturer before the beginning of welding operations on a construction or a group of similar constructions, and/or after a specified number of welds. This number shall be taken from the relevant application standard or shall be laid down in the specification.

The production test is limited to the stud diameter used, the parent material and the type of equipment. For stud welding operations qualified according to 10.3.2 the production test is not required.

14.2.2 Production test for drawn-arc stud welding with ceramic ferrule or shielding gas and short-cycle drawn-arc stud welding

At least ten studs shall be welded. For setting-up tests and, where appropriate, replacement tests, a sufficient number of additional studs should be provided on the test piece. The following examinations and tests shall be performed:

- a) visual examination (all studs);
- b) bend testing (five studs);
- c) macro examinations of two different studs (off-set by 90° through the centre of the stud), only applicable to studs > 12 mm.

NOTE For short cycle drawn-arc stud welding, macro examinations can be replaced by torque tests (five studs).

The examinations and testing are performed and evaluated in accordance with Clause 11. The results of the production test shall be documented (see Annex F).

14.2.3 Production test for capacitor discharge stud welding with tip ignition and capacitor discharge drawn-arc stud welding

At least ten studs shall be welded. For setting-up tests and, where appropriate, replacement tests, a sufficient number of additional studs should be provided on the test piece. The following examinations and tests shall be performed:

- a) visual examination (all studs);
- b) tensile testing (three studs);
- c) bend testing (five studs).

The examination and tests are performed and evaluated in accordance with Clause 11. The results of the production test shall be documented (see Annex G).

14.3 Simplified production test

Simplified production tests shall be performed by the manufacturer before the start of each shift. They can also be requested after a certain number of welds, by the application standard rules or in the specification.

The purpose of the simplified production test is to check that the equipment is correctly set up, and that it is operating correctly. Three studs shall be welded. The simplified production tests comprise at least the following test and examination:

- a) visual examination (all studs);

- b) bend testing (all studs).

The examination and test are performed and evaluated in accordance with Clause 11. The results of the simplified production test shall be documented.

14.4 Re-testing for production test or simplified production test

If one of the studs does not meet the requirements, two additional studs of the same type can be taken from the associated test piece. If this is not possible, similar studs shall be additionally welded.

NOTE This necessitates that a sufficient quantity of replacement specimens be provided in a production test.

If one of the additional studs does not satisfy the requirements, corrective action (see 14.7) shall be taken and the production test shall be repeated.

14.5 Production surveillance

14.5.1 Visual examination

Visual examination is generally sufficient for production surveillance and shall cover all welds.

14.5.2 Checking the welding parameters

The relevant welding parameters shall be checked regularly.

NOTE They can be monitored by suitable equipment.

14.5.3 Other examinations and tests

If specified in the application standard or by agreement between the contracting parties, non-destructive testing may be added to production surveillance. Suitable techniques are:

- a) checking the length of the studs after welding;
- b) tensile test, bend test, torque test with stress values below the elastic limit.

14.5.4 Production surveillance for drawn-arc stud welding with ceramic ferrule with qualification according to 10.3.2

A bend test (15 °) shall be performed on the greater of 5 % or at least on 2 studs on each beam. The following examinations and tests shall be performed on all studs:

- a) visual examination according to 11.2;
- b) ring test according to 11.8.

14.6 Production surveillance record

The manufacturer keeps a production surveillance record, which contains the results of the production test, simplified production test and production surveillance. The manufacturer shall keep a different record for each stud-welding process and the record shall be kept available, with the results of all tests recorded. Annex H is an example form and should be used, where appropriate.

14.7 Non-conformance and corrective actions

If there is an indication of non-conforming welding, e.g. porosity, collar not complete or unequal, unacceptable ring test or if the length of one stud is outside the specification, a bend test (15°) or tensile test (limited to the design strength) shall be performed on that stud. If the stud weld fails to satisfy the requirements in this test, three welds made before and, where appropriate, after the defective weld shall also be subjected to bend or tensile testing.

If one of these studs also fails to satisfy the requirements in the test, appropriate testing shall be carried out on all studs on the same work piece.

Corrective actions shall be taken for all non-conforming stud welds, either by removal of the defective stud, where necessary, and repeat stud welding, or by repair welding with a suitable welding process. In isolated cases, stud welding processes may be replaced by other suitable welding processes. Depending on the stud diameter, a fillet weld shall reach the calculated throat.

NOTE Sometimes defective studs do not need to be removed, but can be substituted by extra studs.

Alternative welding procedures shall be qualified in accordance with ISO 15614-1 or ISO 15614-2, and welders shall be qualified in accordance with ISO 9606-1 or ISO 9606-2.

All repaired or replaced studs shall be tested in accordance with the specifications.

In addition, steps shall be taken to ensure that factors adversely affecting the stud welding are identified and compensated.

14.8 Calibration of the measuring and testing equipment

In the case of comprehensive quality requirements in accordance with ISO 3834-2, the manufacturer shall be responsible for the appropriate calibration of inspection, measuring and testing equipment. All equipment shall be suitably controlled and shall be calibrated at specified intervals (see ISO 17662). See also Annex B.

NOTE In the case of drawn-arc stud-welding processes, this applies particularly to current intensity and welding time measurement

Annex A (informative)

Processing of stud welding

A.1 General

This annex gives general guidance for the satisfactory production and control of stud welding.

In stud welding, an arc is briefly struck between the face of the stud and the work piece; both parts start to melt and are then joined. Depending on the nature of the ignition method, a distinction is made between drawn-arc stud welding and stud welding with tip ignition. Each method requires suitable power supplies, actuating devices, studs and accessories (e.g. ceramic ferrules). A feature of stud welding is the very short arc burn time (approximately 0,5 ms to 3 000 ms) and the associated high rate of heating and cooling. Normally the diameter of the stud can range up to 10 mm for tip ignition welding, and up to 25 mm for drawn-arc welding.

A.2 Welding processes

A.2.1 Drawn arc stud welding

A.2.1.1 General

Drawn arc stud welding can be done mechanically or automatically, using welding gun or welding heads. The stud is inserted into the stud holder and - fitted with a ceramic ferrule, if necessary - applied to the work piece. At the beginning of the welding process, the stud is lifted by the mechanism and, normally, first a pilot arc, then the main arc, are struck between the tip of the stud and the work piece. This causes the face of the stud and the parent material to melt. When the welding time has elapsed, the stud is plunged with little force (< 100 N) into the molten pool, and the current source is switched off. The ceramic ferrule is then removed. Figure A.1 shows the sequence of events using a ceramic ferrule.

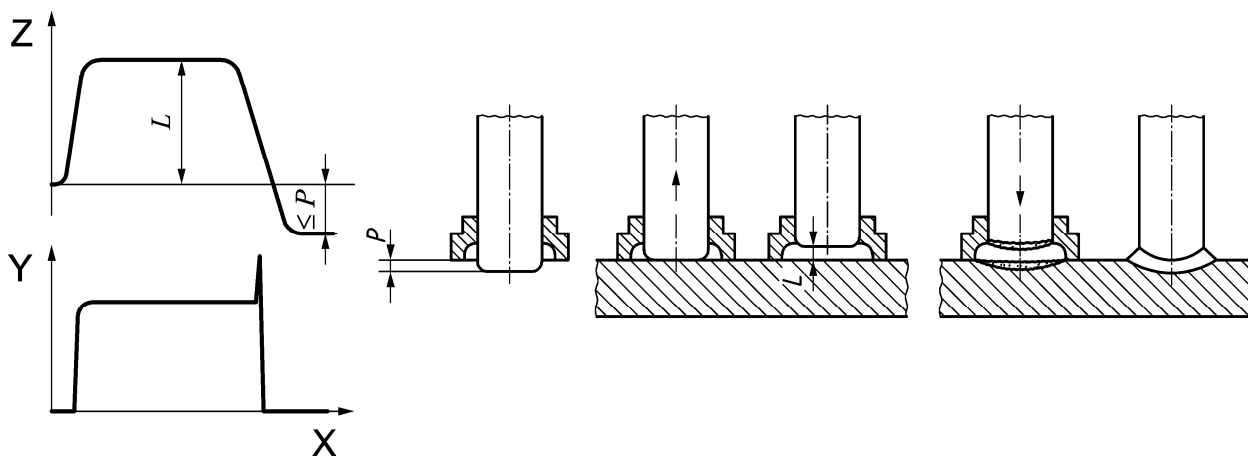

| | | |
|---------------------|-----------|-----------------|
| Key | | |
| <i>L</i> lift | X time | Z stud movement |
| <i>P</i> protrusion | Y current | |

Figure A.1 — Stud movement in drawn-arc stud welding

A.2.1.2 Methods of drawn-arc stud-welding processes

A distinction is made between three methods of welding processes (see Table A.1).

- a) **Drawn arc stud welding with ceramic ferrule or shielding gas (783).** This welding process is generally used in the 3 mm to 25 mm diameter range, with welding times of 100 ms to 3 000 ms. It is usually carried out with a ceramic ferrule or shielding gas, or with both, or in special cases without pool protection. This method is used for the majority of applications. The minimum parent metal thickness is $0,25 d$ for CF and $0,125 d$ for SG, but not less than 1 mm.
- b) **Short-cycle drawn-arc stud welding (784).** A welding time of ≤ 100 ms is used. This variant is suitable for stud diameters up to 12 mm, but for the range between approximately 8 mm and 12 mm, stud diameter shielding gas should be used to prevent increased pore formation. For aluminium, shielding gas shall be used. The fusion zone is narrow and the thermal input modest, so that studs up to 12 mm diameter can be welded to thin parent metals. For diameters up to 9 mm diameter and with steel, the operation is frequently carried out without protection of the weld pool and calls for studs with an upset flange, as these afford a larger weld area than the plain stud-shaft diameter and thus reach a higher tensile force than the stud shaft, despite pores in the weld zone. The minimum parent metal thickness is $0,125 d$, but not less than 0,6 mm.
- c) **Capacitor discharge drawn-arc stud welding (785).** Very short welding time (< 10 ms) can be achieved by using a capacitor discharge power source. The diameter range is 3 mm to 10 mm. The minimum parent metal thickness is $0,1 d$, but not less than approximately 0,5 mm. The welding process is similar to the short-cycle drawn-arc stud-welding process, but the peak current can be up to 4 000 A.

The working range of the various drawn-arc stud-welding processes is given in Table A.1.

Table A.1 — Working range of the various drawn-arc stud-welding processes

| Welding processes ^a | Welding time t_w ms | Welding diameter, d_w , and welding positions ^b mm | Current intensity I A | Weld pool protection | Minimum parent metal thickness mm |
|--|-----------------------------|---|-------------------------------|----------------------|--|
| Drawn-arc stud welding with ceramic ferrule or shielding gas (783) | > 100 | 3 to 25 PA 3 to 20 PE 3 to 16 PC | 300 to 3 000 | CF | $0,25d$, but not less than 1 mm ^c |
| | > 100 | 3 to 16 PA 3 to 8 PC | 300 to 2 000 | SG | $0,125d$, but not less than 1 mm ^c |
| Short-cycle drawn-arc stud welding (784) | < 100 | 3 to 12, all welding positions | Up to 1 800 | NP, SG | $0,125d$, but not less than 0,6 mm ^c |
| Capacitor discharge drawn-arc stud welding (785) | < 10 | 3 to 10, all welding positions | Up to 4 000 (peak) | NP, (SG) | $0,1d$, but not less than app. 0,5 mm |

^a In accordance with ISO 4063

^b In accordance with ISO 6947.

^c The minimum parent metal thickness avoids the risk of burning through the parent metal. Other application requirements may call for greater thicknesses.

When the high-power welding process (narrow melt zone), short-cycle welding process or the capacitor discharge process is used, the stud tips shall be matched to the fusion penetration shape in the work piece and made flatter (e.g. 166° cone angle).

A.2.1.3 Weld pool protection

A distinction is made between different techniques on the basis of weld pool protection.

a) **Ceramic ferrule (CF).** The ceramic ferrule has several functions:

- protection of the weld pool by creation of metal vapour in the burning chamber at sufficient current intensity;
- concentration and stabilization of the arc, thus reducing arc blow;
- moulding of the displaced weld pool to a weld collar and supporting of the weld pool.

Furthermore, it shields the operator from both arc and spatter. The ceramic ferrule is used for one weld only and is removed once the molten metal has solidified.

b) **Shielding gas (SG).** In stud welding with shielding gas, the atmosphere is displaced from the arc region by a shielding gas supplied from outside, which greatly reduces the formation of pores. For steels and most other metals, a mixture of argon and carbon dioxide (ISO 14175-M21) is widely used. For aluminium and its alloys, pure argon Ar 99,99 (ISO 14175-I1) or Argon-Helium mixtures (ISO 14175-I3) are widely used.

The shielding gas influences the arc and affects the fusion of the stud and work piece. It also influences the shaping of the weld collar and the penetration shape, via the surface tension. A fundamental principle is that the welding position PA, in accordance with ISO 6947, should be preferred for welding time > 100 ms. An additional ceramic ferrule can also be used to improve the shape of the collar and restrict the arc to the immediate area of the work piece.

c) **No protection (NP).** Stud welding without protection is possible only for small welding diameters (< 10 mm) and with short welding times (< 100 ms). Among the drawbacks of this method are severe oxidation of the weld zone, increased pore formation and an irregular weld collar.

A.2.2 Capacitor discharge stud welding with tip ignition (786)

The two techniques for capacitor discharge stud welding with tip ignition are with contact or with gap.

Table A.2 — Characteristics for capacitor discharge stud welding with tip ignition

| Method | Characteristic | | | | | | | Typical application |
|----------------|------------------------------|---------------------------------|--------------------------|---------------------------|------------------------------------|---------------------------------|--|---|
| | Welding process ^a | Welding diameter d_w mm | Peak current I A | Welding time t ms | Spring force F N | Plunging speed v m/s | Ignition | |
| Contact method | 786 | 0,8 to 10 | 10 000 | 2 to 10 | 60 to 100 depending on piston mass | 0,5 to 0,7 | Always correct | Welding of (unalloyed and alloyed) steel, galvanized or oily surfaces |
| Gap method | 786 | 0,8 to 10 (aluminium up to 6) | 15 000 | 0,5 to 3 | 40 to 60 | 0,5 to 1, aluminium 1 up to 1,5 | Mostly correct, advanced ignition possible | Welding of aluminium and brass |

^a In accordance with ISO 4063.

In welding with contact, the stud is inserted into the stud holder of the machine [see Figure A.2 a)] and positioned with its ignition tip directly on the surface of the component [see Figure A.2 b)]. A spring in the welding gun presses the stud against the metal. Once the capacitor power has been switched on, the ignition tip abruptly explodes and vaporizes partially, and the arc is generated [see Figure A.2 c)]. The stud is advanced still further towards the parent metal and finally remains in the solidified melt [see Figure A.2 d)]. The welding time is ≤ 3 ms.

The difference between welding with gap and the technique described above is that, before welding begins, the stud is held at a defined, adjustable distance from the work piece [see Figure A.2 a)].

When the capacitor bank is switched on, the stud is speeded up towards the surface of the metal, and the welding process continues as described above [see Figures A.2 b), A.2 c) and A.2 d)]. A welding time of about 1 ms makes it possible, among other things, to weld aluminium and its alloys without gas shielding.

The recommended parent metal thickness should be $\geq 0,1 d$ but not less than approximately 0,5 mm.

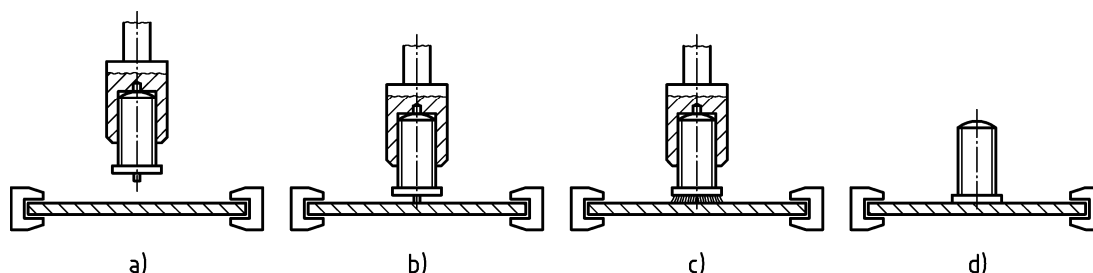

Figure A.2 — Capacitor discharge stud welding with tip ignition — Main phases of the welding process

A.2.3 Parent materials

A.2.3.1 General

The brief arc effect initiates melting of both stud and parent material, and the molten metals intermix as the joint is formed. This phenomenon differs in the various stud-welding processes. Generally speaking, more stud material melts than parent material. The weld area on the parent material is usually larger than the cross-section of the stud. The strength and deformation properties at the transition from weld to stud shall therefore be investigated with special attention. The surface of the parent material should be clean. Layers of paint, rust, scale, grease and coatings of non-weldable metals should be removed from the weld location. This can be done mechanically or chemically. Parent materials with scale and rust layers shall be thoroughly ground off. The surface preparation shall be specified in the WPS. Where welding times are short (< 50 ms), the surface should be cleaned with particular care.

A.2.3.2 Parent material for drawn-arc stud welding with ceramic ferrule or shielding gas and short-cycle drawn-arc stud welding

Parent materials for this type of stud welding are those listed in Table A.3.

The use of other steel grades and other materials such as lead-free brass for drawn-arc stud welding, can also be permitted. In such cases, additional or other tests, as described in Clause 11, can be required.

A.2.3.3 Parent material for capacitor discharge drawn-arc stud welding and capacitor discharge stud welding with tip ignition

Parent materials for this type of stud welding are those listed in Table A.4.

The use of other materials is also permitted. In such cases, alternative or additional tests, such as those described in Clause 11, may be required.

A.2.4 Studs

A.2.4.1 Stud material

Stud materials are listed in ISO 13918:2008, Table 2.

A.2.4.2 Stud shapes

The stud shape outside the weld area can be chosen freely. The shape of the stud tip differs according to welding process and material (see ISO 13918).

A.2.5 Combinations of stud material and parent material

The weldability of the various materials, as well as the recommended combinations of stud material and parent material, depends on the process of stud welding. The combinations are shown in Tables A.3 and A.4.

Other combinations can be welded, but the weldability should be assured by welding procedure qualification.

Table A.3 — Weldability of typical combinations of stud and parent materials for drawn-arc stud welding with ceramic ferrule or shielding gas and short-cycle drawn-arc stud welding

| Stud material | Parent material | | | |
|---|---|--|--|--|
| | ISO/TR 15608 material groups 1 and 2.1 | ISO/TR 15608 material groups 2.2, 3 to 6 | ISO/TR 15608 material groups 8 and 10 | ISO/TR 15608 material groups 21 and 22 |
| S235 4.8 (weldable) 16Mo3 | highly weldable for any application ^a | weldable within limits ^b | weldable within limits ^{b, c} | not weldable |
| 1.4742/X10CrAl18 1.4762/X10CrAl24 | weldable within limits ^d | weldable within limits ^d | weldable within limits ^d | not weldable |
| 1.4828/X15CrNiSi20 1.4841/X20CrNiSi25-4 | weldable within limits ^b | weldable within limits ^b | weldable within limits ^b | not weldable |
| 1.4301/X5CrNi18-10 1.4303/X5CrNi18-12 1.4401/X5CrNiMo17-12-2 1.4529/X1NiCrMoCuN25-20-7 1.4541/X6CrNiTi18-10 1.4571/X5CrNiMoTi17-12-2 | weldable within limits ^b / highly weldable for any application ^{a, e} | weldable within limits ^b | highly weldable for any application ^a | not weldable |
| EN AW-AlMg3/EN AW-5754 EN AW-AlMg5/EN AW-5019 | not weldable | not weldable | not weldable | weldable within limits ^b |
| ^a For example, for force transfer. ^b For force transfer. ^c Only for short-cycle drawn-arc stud welding. ^d Only for heat transfer. ^e Up to 12 mm in diameter. | | | | |

Table A.4 — Weldability of typical combinations of stud and parent materials for capacitor discharge stud welding with tip ignition and for capacitor discharge drawn-arc stud welding

| Stud material | Parent material | | | | |
|--|--|--|--|--|--|
| | ISO/TR 15608 material groups 1 to 6, 11.1 | ISO/TR 15608 material groups 1 to 6, 11.1 and galvanized and metal coated steel sheet, max. thickness 25 µm of coating | ISO/TR 15608 material group 8 | Copper and lead free copper alloys, e.g. CuZn37 (CW508L) | ISO/TR 15608 material groups 21 and 22 |
| S235 4.8 (weldable) | highly weldable for any application ^a | weldable within limits ^b | highly weldable for any application ^a | weldable within limits ^b | not weldable |
| 1.4301 1.4303 | highly weldable for any application ^a | weldable within limits ^b | highly weldable for any application ^a | weldable within limits ^b | not weldable |
| CuZn37 (no ISO standard available) | weldable within limits ^b | weldable within limits ^b | weldable within limits ^b | highly weldable for any application ^a | not weldable |
| EN AW-Al99,5 | not weldable | not weldable | not weldable | not weldable | weldable within limits ^b |
| EN AW-AlMg3 | not weldable | not weldable | not weldable | not weldable | highly weldable for any application ^a |
| ^a For example, for force transfer. ^b For force transfer | | | | | |

A.2.6 Weld assessment and recommended corrective actions

Weld assessment and recommended corrective actions are shown in Tables A.5, A.6, A.7 and A.8.

Table A.5 — Weld assessment and recommended corrective actions for drawn-arc stud welding with ceramic ferrule or shielding gas

| No. | Appearance | Assessment | Recommended corrective actions |
|--|---|--|---|
| Visual examination or macro cut | | | |
| 1 | Collar regular, bright and complete. Length after weld within tolerances.  | Acceptable (parameters are correct). | None. |
| 2 | Reduced diameter weld. Length too long.  | Insufficient protrusion (plunge) or lift. Insufficient centering. Welding power too high. Damping activity too strong. | Increase protrusion (plunge) or lift. Check centering of ceramic ferrule. Reduce current and/or welding time. Reduce damping activity. |
| 3 | Reduced, irregular and greyish collar. Length too long.  | Weld power too low. Ceramic ferrule is moist. Lift too short. | Increase current and/or welding time. Use dry ferrules only. Increase lift. |
| 4 | Collar off centre with unacceptable undercut (see 12.6)  | Effect of arc blow. Ceramic ferrule incorrectly centred. | See Table A.8. Improve centring. |

Table A.5 (continued)

| No. | Appearance | Assessment | Recommended corrective actions |
|--|---|---|---|
| Visual examination or macro cut | | | |
| 5 | Collar height extremely reduced, bright, large lateral projections. Length after weld too short.  | Weld power too high. Plunge rate too high. | Reduce current and/or welding time. Adjust plunge and/or welding gun damper. |
| Fracture examination | | | |
| 6 |  | Acceptable (parameters are correct). | None. |
| 7 | Fracture above collar after sufficient deformation.  | Acceptable (parameters are correct). | None. |
| 8 | Fracture within the weld. High porosity.  | Weld power too low. Unclean surface. Material not suitable for stud welding. | Increase current and/or welding time. Clean the surface. Select suitable material. |

Table A.5 (continued)

| No. | Appearance | Assessment | Recommended corrective actions |
|-----------------------------|---|---|---|
| Fracture examination | | | |
| 9 | Fracture in HAZ. Greyish fracture surface without sufficient deformation.  | Hardening increased. Cooling rate too high. | Select suitable material. Increase welding time. Preheating may be necessary. |
| 10 | Fracture of weld. Bright appearance.  | Flux content is too high. Welding time too low. | Reduce flux quantity. Increase welding time. |
| 11 | Lamellar tearing of parent material.  | Non-metallic inclusions in parent material. Parent material not suitable. | Select suitable material. |
| 12 | Fracture in the weld after insufficient deformation Lack of fusion in the border area  | Cold plunge (plunging speed too low, damping activity too strong, extraordinary friction ...) | Provide hot plunge Reduce damping activity. |
| 13 | Burn through  | Weld pool penetrates parent metal | Increase parent metal thickness Reduce power input (welding time) |

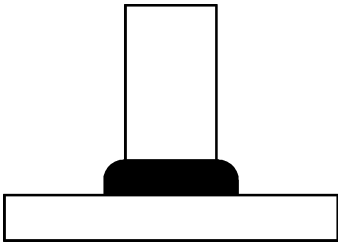
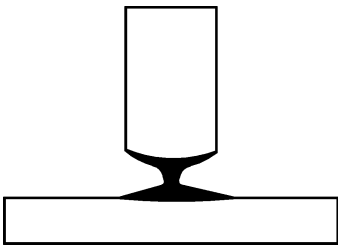
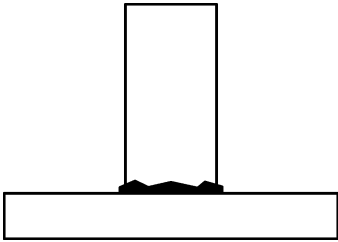
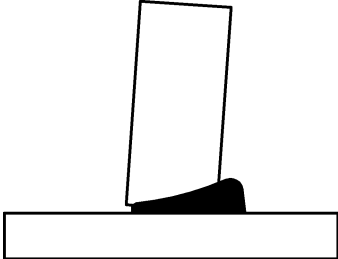
Table A.6 — Weld assessment and recommended corrective actions for short-cycle drawn-arc stud welding

| No. | Appearance | Assessment | Recommended corrective actions |
|--|---|--|--|
| Visual examination or macro cut | | | |
| 1 | Regular collar, no visual defects.  | Acceptable (parameters are correct). | None. |
| 2 | Partial weld.  | Weld power too low. Polarity incorrect. | Increase current and/or welding time. Correct polarity. |
| 3 | Large irregular collar.  | Welding time too long. | Reduce welding time. |
| 4 | Pores in collar.  | Welding time too long. Current too low. Oxidation of weld pool. Surface contaminated. | Reduce welding time. Increase current. Provide suitable shielding gas. Clean the surface. |

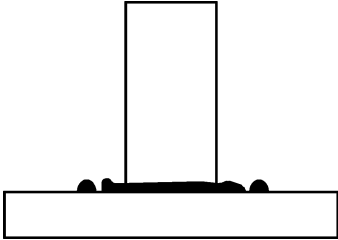
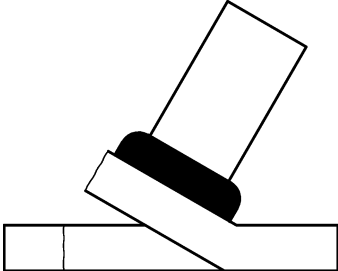
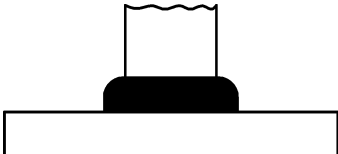
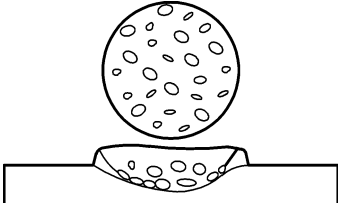
Table A.6 (continued)

| No. | Appearance | Assessment | Recommended corrective actions |
|-----------------------------|---|--|---|
| Fracture examination | | | |
| 5 | Collar off centre with unacceptable undercut (see 12.6).  | Effect of arc blow. | See Table A.8. |
| 6 | Tearing of parent material.  | Acceptable (parameters are correct). | None. |
| 7 | Fracture above collar after sufficient deformation.  | Acceptable (parameters are correct). | None. |
| 8 | Fracture in HAZ.  | Carbon content of parent material too high. Parent material not suitable. | Select suitable material. |
| 9 | Lack of penetration.  | Heat input too low. Incorrect weld polarity. | Increase heat input. Correct weld polarity. |

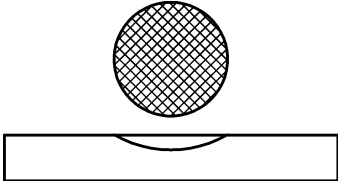
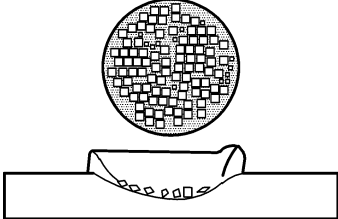
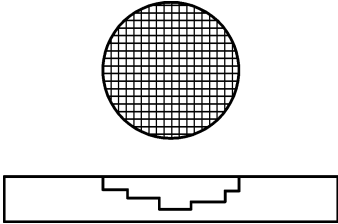
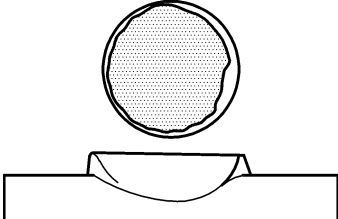
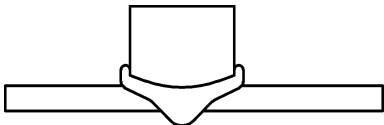
Table A.7 — Weld assessment and recommended corrective actions for capacitor discharge drawn-arc stud welding and capacitor discharge stud welding with tip ignition

| No. | Appearance of fracture | Assessment | Recommended corrective actions |
|---------------------------|--|---|--|
| Visual examination | | | |
| 1 | <p>Small weld spatter around joint. No visual defects.</p>  | <p>Acceptable (parameters are correct).</p> | <p>None.</p> |
| 2 | <p>Gap between flange and parent material.</p>  | <p>Weld power too low. Plunging speed too low. Insufficient support of parent material.</p> | <p>Increase weld power. Correct plunging speed. Provide support.</p> |
| 3 | <p>Considerable spatter around weld.</p>  | <p>Weld power too high and/or insufficient plunging speed.</p> | <p>Reduce weld power. Increase plunging speed.</p> |
| 4 | <p>Weld spatter off centre with undercut.</p>  | <p>Effect of arc blow.</p> | <p>See Table A.8.</p> |

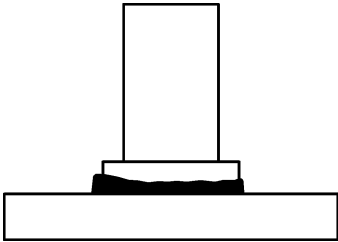
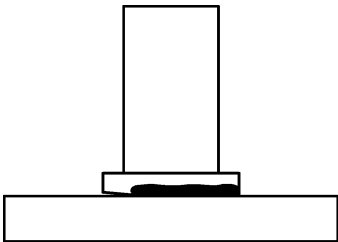
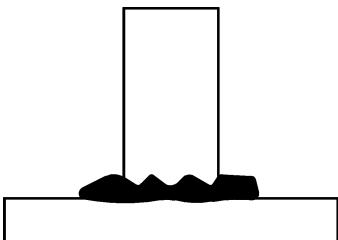
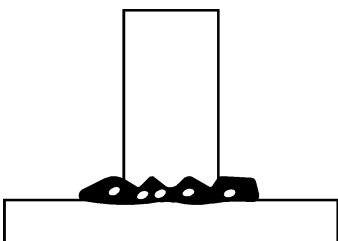
Table A.7 (continued)

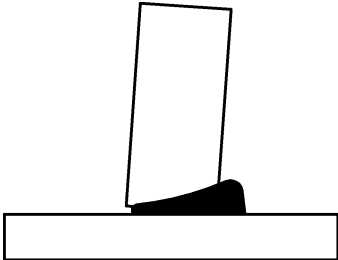
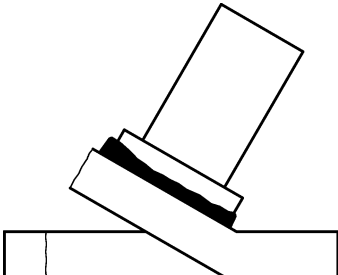
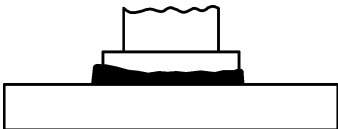
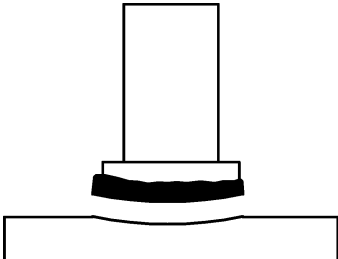
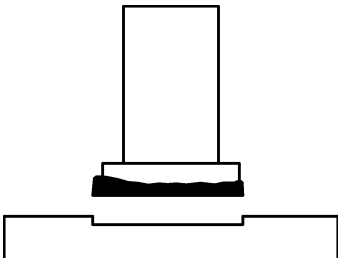

| No. | Appearance of fracture | Assessment | Recommended corrective actions |
|-----------------------------|--|--|---|
| Fracture examination | | | |
| 5 | Tearing of parent material.  | Acceptable (parameters are correct). | None. |
| 6 | Fracture of stud above flange.  | Acceptable (parameters are correct). | None. |
| 7 | Fracture in weld.  | Weld power too low. Plunging speed too low. Combination stud/parent material unsuitable. | Increase weld power. Increase plunging speed. Select suitable material. |

Table A.8 — Effect of arc blow and some possible remedies

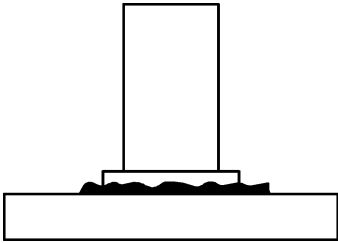
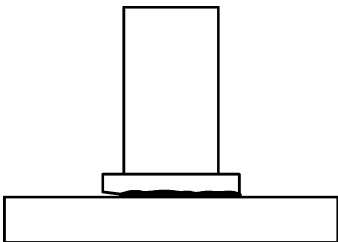
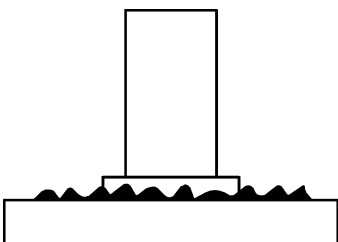
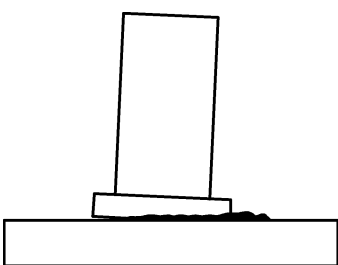
| No. | Cause | Remedy |
|---|---|--|
| A |  |  |
| B |  |  |
| C |  |  |
| <p>NOTE Arc blow is proportional to current intensity and can be influenced by symmetrically attaching mass clamps and compensating masses, or (in the case of hand welding guns with an external welding cable) by turning the welding gun around the vertical axis. Arc blow generates one-sided melting and can increase the number of pores in the welded materials, but it can be reduced by suitable application of different remedies.</p> | | |

A.2.7 Drawn arc stud welding with ceramic ferrule or shielding gas and short-cycle drawn-arc stud welding

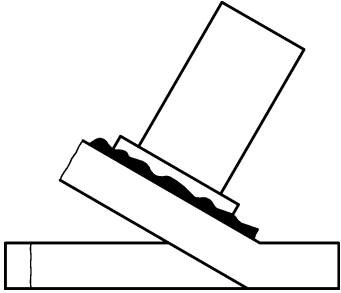
A.2.7.1 Welding equipment

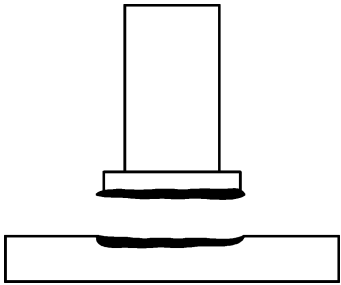
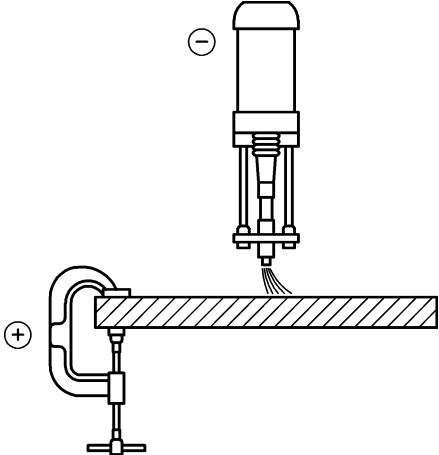
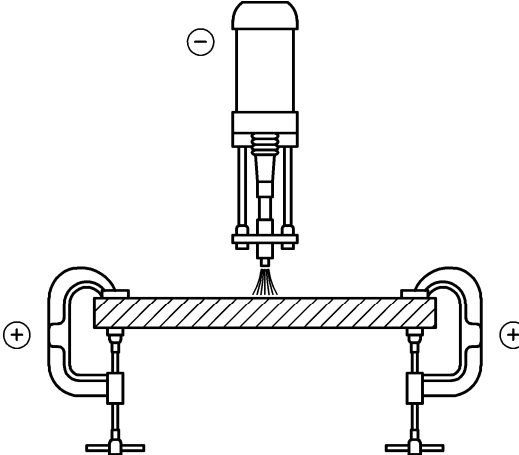
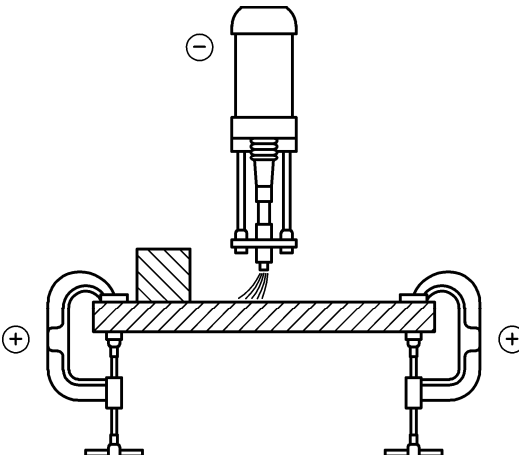
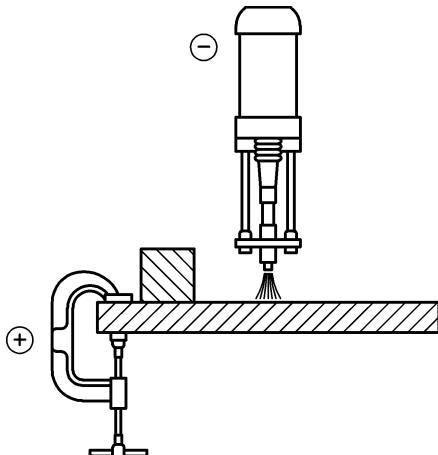
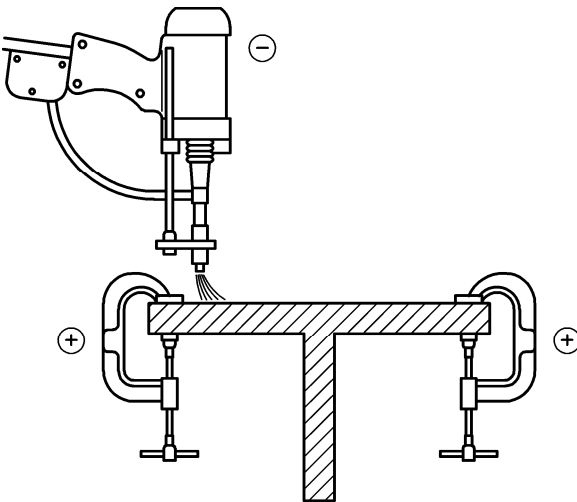
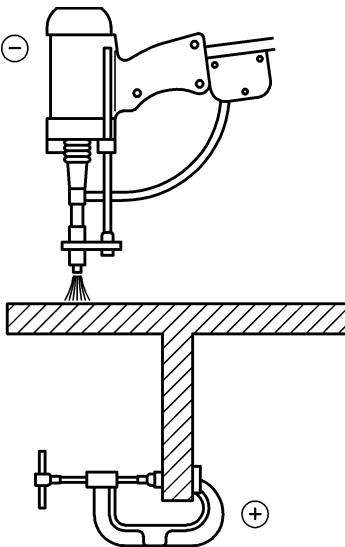
A.2.7.1.1 General

The welding equipment consists of the power source, control unit, movable fixture and welding cables.

A.2.7.1.2 Power sources

Power sources are either rectifiers or converters which supply direct current and are suitable for brief, high loads. The maximum current intensity in the case of the largest standard studs is approximately 2 500 A. The duty cycle is 3 % to 10 %. This means that even for high currents, systems are relatively light and compact. The open circuit voltage should conform to IEC 60974-1.

NOTE It is intended that the current intensity be continuously adjustable over the entire range. Systems incorporating constant current control are particularly advantageous.

A.2.7.1.3 Control unit

Control units switch the welding current in accordance with the desired welding time. They also control the movement of the welding gun. The power source and control unit are combined in most systems (compact systems).

A.2.7.1.4 Movable fixtures

Movable fixtures are either hand-held welding guns or welding heads. Welding heads are preferable for automatic stud feed and are securely connected to a frame.

The movable fixture incorporates the following:

- a) the drive, to lift the stud for arc starting and to keep the lift at a constant length during the arc time, with respect to the support fixture;

NOTE 1 In most cases, the drive is electromagnetic.

- b) a spring, to plunge the stud into the molten pool after the end of the welding period;
- c) on some welding guns, a hydraulic or pneumatic damper, to reduce the plunge speed;

NOTE 2 In particular, a damper is incorporated when stud diameters are in excess of 14 mm.

- d) a clamping fixture, to hold the stud in the welding position and to transfer the current to the stud;
- e) a support fixture, to absorb the reaction force of the press-on force;

NOTE 3 In the case of hand welding guns, the support fixture can centre the ceramic ferrule or allow the stud to be positioned on the work piece (e.g. by way of stops or templates). The support can be made either directly mechanically, or by means of electronic control.

- f) in the case of welding heads for automatic feed, a feed chamber and a positioning unit for the stud.

NOTE 4 In most cases, the positioning unit is pneumatic.

Changing clamping fixtures, and sometimes parts, of the support fixture enables a movable fixture to be used for different stud dimensions.

The movable fixture is a power tool. The appropriate safety regulations should therefore be observed in order to avoid hazards connected with electrical voltage, heating and arc formation.

A.2.7.1.5 Welding cables

The welding cables shall conform to ISO 5828 and shall be dimensioned so that impermissible heating is avoided. 50 mm² is recommended for studs with a diameter of up to 12 mm. Cross-sections of at least 70 mm² are recommended for studs of up to 20 mm diameter. Cross-sections of 120 mm² are recommended for larger studs. The cable and, in particular, all connection points should be checked regularly for damage. Damaged system components shall be replaced.

NOTE Depending on the type of power source and the length of the welding cable, the cross-section of the welding cables is increased.

A.2.7.2 Welding parameters

A.2.7.2.1 Polarity

When welding steel, the stud is connected to the negative pole and the work piece is connected to the positive pole. Opposite polarity has proven successful for special metals, e.g. aluminium and its alloys, and brass.

A.2.7.2.2 Weld current setting

Depending on the stud dimensions, the welding current is set between approximately 300 A and 3000 A. For drawn-arc stud welding with ceramic ferrule or shielding gas of unalloyed steel, the correct current setting can be estimated on the basis of Equations (A.1) and (A.2):

$$I \text{ (A)} = 80 \times d \text{ (mm)} \text{ — for studs up to approximately 16 mm diameter} \quad (\text{A.1})$$

$$I \text{ (A)} = 90 \times d \text{ (mm)} \text{ — for studs over 16 mm diameter} \quad (\text{A.2})$$

Normally, a current setting approximately 10 % less is selected for stainless steel.

A current as high as possible (600 A to 1 800 A, depending on the size of the power source) is set for short-cycle drawn-arc stud welding.

A.2.7.2.3 Arc voltage

The arc voltage is mainly determined by the lifting height and the welding current. Values of between 20 V and 40 V are the norm. Surface impurities, such as oil or grease, increase the arc voltage compared with the normal state, whilst inert gases reduce it.

A.2.7.2.4 Welding time

For drawn-arc stud welding with ceramic ferrule or shielding gas, the welding time can be estimated on the basis of Equations (A.3) and (A.4):

$$t_w \text{ (s)} = 0,02 \times d \text{ (mm)} \text{ — for studs of up to approximately 12 mm diameter} \quad (\text{A.3})$$

$$t_w \text{ (s)} = 0,04 \times d \text{ (mm)} \text{ — for studs over 12 mm diameter} \quad (\text{A.4})$$

The given values apply to weldings in the welding position PA. The welding time shall be reduced for welding in the welding position PC, in accordance with ISO 6947.

In the case of short cycle stud welding, the welding time is less than 100 ms. It depends not only on the stud diameter, but also on the available current intensity. The welding time should be as short as possible in the case of welding without weld pool protection.

A.2.7.2.5 Lift

The lift is between approximately 1,5 mm and 8 mm and is proportional to the stud diameter. In the case of coated surfaces (e.g. through-deck-welding technique), the lift shall be greater than normal. Greater lift increases the arc length and therefore the arc voltage. The magnetic deflection of the arc also increases (arc blow).

A.2.7.2.6 Protrusion

Generally, the protrusion is 1 mm to 8 mm and proportional to the stud diameter. It also depends on the desired shape of the weld collar, the shape of the stud base and (when welding with a ceramic ferrule) the collar area of the ferrule.

A.2.7.2.7 Plunging speed

The plunging speed should be approximately 200 mm/s for studs with a diameter of up to 14 mm diameter and 100 mm/s for larger studs, so as to prevent the weld pool splashing. It is proportional to the protrusion in the case of movable fixtures without dampers.

A.2.8 Capacitor discharge drawn-arc stud welding and capacitor discharge stud welding with tip ignition

A.2.8.1 Welding equipment

A.2.8.1.1 General

The welding equipment consists of the power source, incorporating a charging unit, the movable fixture and the welding cable.

A.2.8.1.2 Power source

The power source incorporates a capacitor bank with capacitances of between approximately 12 mF and 150 mF. The capacitance is sometimes adjustable in steps. The charging voltages are up to approximately 200 V and require a safety switch-off facility conforming to IEC 60974-1. In most cases, the charging voltages are continuously adjustable.

Drawn arc capacitor discharge power sources have an additional coil in the welding circuit to provide a welding time of 6 ms to 10 ms.

The capacitor bank shall be charged to the desired voltage before every welding operation. The maximum welding sequence depends on the charging speed. Approximately 500 studs per hour can be welded with manual-operated power sources, and up to 3 500 studs per hour can be welded in automatic mode.

A.2.8.1.3 Movable fixture

The movable fixtures are either hand welding guns or welding heads. Welding heads are preferable for automatic stud feed and are securely connected to a frame. In the drawn-arc method, the arc is created by lifting the stud. In the tip ignition method, the electromagnetic drive creates a gap between stud material and parent material. The arc is ignited by contact of the tip to the work piece. The design of the movable fixture depends on whether the method used for starting the arc is the drawn-arc or capacitor discharge method. The movable fixture incorporates the following:

- a) the drive, to lift the stud and to keep the lift at a constant length during the arc time, with respect to the support fixture;

NOTE 1 In most cases, the drive is electromagnetic.

- b) a spring, to plunge the stud into the molten pool after the end of the welding period;

- c) a clamping fixture, to hold the stud in the welding position and to transfer the current to the stud;
- d) a support fixture, to absorb the reaction force of the press-on force;

NOTE 2 In the case of hand welding guns, the support fixture allows the stud to be positioned on the work piece, (e.g. by way of stops or templates). The support can be made either directly mechanically, or by means of electronic control.

- e) in the case of welding heads for automatic feed, a feed chamber and a positioning unit for the stud.

NOTE 3 In most cases, the positioning unit is pneumatic.

An electromagnetic drive is not absolutely essential in the case of movable fixtures operating with stud welding with tip ignition. Springs tensioned by hand can also be used to create the necessary arc gap.

Changing clamping fixtures enables a movable fixture to be used for different stud dimensions.

The movable fixture is a power tool. The appropriate safety regulations should therefore be observed in order to avoid hazards connected with electrical voltage, heating and arc formation.

A.2.8.1.4 Welding cables

Welding cables should be used in accordance with ISO 5828.

The cross-sections of the welding cables are generally 25 mm² to 70 mm². They should be as short as possible, due to the high peak currents and the associated voltage drop. Winding the welding cable into coils increases the inductive resistance, which in turn reduces the welding current, but the welding time is increased.

A.2.8.2 Welding parameters

A.2.8.2.1 Polarity

In general, the stud is connected to the negative pole and the work piece is connected to the positive pole. Reverse polarity can be advantageous for copper and aluminium alloys.

A.2.8.2.2 Welding current

The peak current is between 1 000 A and 10 000 A and depends on the charging voltage, the capacitance and the inductive and ohmic resistance of the welding cable.

A.2.8.2.3 Welding time

The welding time cannot be selected directly. Depending on the stored energy and the inductance of the welding circuit, it is 1 ms to 3 ms (tip ignition), or 3 ms to 10 ms (drawn-arc). A longer welding time simplifies welding on a coated surface, by virtue of better degassing.

A.2.8.2.4 Charging energy

Together with the capacitance, the charging voltage determines the charging energy on the basis of Equation (A.5):

$$W = 0,5 \times C \times U_2 \quad (A.5)$$

The charging energy shall be increased with the weld cross-section.

A.2.8.2.5 Plunging speed

The plunging speed is in general determined by a spring and the mass of the moving parts. With some movable fixtures, the spring force can be changed by the operator. The plunging speed is approximately 0,5 m/s to 1,5 m/s (sometimes more). In the case of the tip ignition method, it directly determines the welding time, in conjunction with the stud tip length. It is therefore necessary to maintain the plunging speed within limits at all times, in order to obtain a constant quality.

Annex B
(normative)

Quality requirements for stud welding

Table B.1 shows quality requirements for stud welding.

Table B.1 — Quality requirements for stud welding

| Quality requirements in ISO 3834-2, ISO 3834-3 or ISO 3834-4 required for stud welding | Comprehensive quality requirements in accordance with ISO 3834-2 | Standard quality requirements in accordance with ISO 3834-3 | Elementary quality requirements in accordance with ISO 3834-4 |
|---|--|--|---|
| Fields of application unless otherwise specified | Studs subjected to fatigue loading | Studs subjected to specified static loading | Studs subjected to unspecified static loading, e.g. furnace construction, heat resistant applications |
| Technical knowledge of welding coordination personnel | Basic knowledge in accordance with 6.2 | | 6.2 does not apply |
| Quality record | Production surveillance record in accordance with 14.6 | | 14.6 does not apply |
| Method of qualification of pWPS | Welding procedure test in accordance with 10.2 or pre-production test in accordance with 10.3 | | Previous experience in accordance with 10.4 |
| Calibration of measurement and testing equipment | Procedures shall be available in accordance with 14.8 | 14.8 does not apply | |
| Process control | Production test in accordance with 14.2; simplified production test in accordance with 14.3; production surveillance in accordance with 14.5 | | Simplified production test in accordance with 14.3, production surveillance in accordance with 14.5 |

Annex C
(informative)

Manufacturer's welding procedure specification (WPS)

| | |
|----------------------------------|---|
| Manufacturer's welding procedure | Examiner or Examining body |
| Reference No.: | Reference No.: |
| Manufacturer: | Stud-welding process: |
| WPQR No.: | Method of cleaning or |
| Parent material: | surface condition of parent material: |
| Parent material thickness (mm): | Stud material: |
| Preheat temperature (°C): | Stud designation: |
| Shielding gas and flow rate: | Stud diameter (mm): |
| Ceramic ferrule designation: | Use of damper: <input type="checkbox"/> yes <input type="checkbox"/> no |
| Power source: | |
| Welding gun/head: | Welding position: |

| Drawn arc stud welding with ceramic ferrule or shielding gas and short-cycle drawn-arc stud welding | Welding current | Welding time | Protrusion | Lift | Remarks |
|--|------------------------|---------------------|-------------------|-------------|----------------|
| | A | ms | mm | mm | |
| | | | | | |

| Capacitor discharge stud welding with tip ignition and capacitor discharge drawn-arc stud welding | Gap mm | Charging voltage V | Capacitance mF | Spring force N or plunging speed mm/s | Remarks |
|--|----------------------|----------------------------------|------------------------------|--|----------------|
| | | | | | |

Additional remarks:

.....

.....

| | |
|-----------------------------|------------------------------------|
| Manufacturer: | Examiner or Examining body: |
| (Name, date and signature): | (Name, date and signature): |

Annex D
(informative)

Welding procedure qualification record form (WPQR) (for drawn-arc stud welding with ceramic ferrule or shielding gas and short-cycle drawn-arc stud welding)

Welding procedure qualification — Test certificate

Manufacturer:

Examiner or Examining body:

Address:

Code/testing standard:

Date of welding:

Manufacturer's welding procedure

Reference No.:

Name of operator:

Extent of qualification

Stud-welding process:

Stud diameter (mm):

Stud material:

Stud length (mm):

Parent material:

Stud designation:

Parent material thickness (mm):

Application > 100 °C Application 100 °C

Ceramic ferrule designation:

Use of damper: yes no

Welding position:

Power source:

Preheat temperature (°C)

Welding gun/head:

Shielding gas and flow rate:

Other information:

.....

.....

| Welding current | Welding time | Protrusion | Lift | Remarks |
|-----------------|--------------|------------|------|---------|
| A | ms | mm | mm | |
| | | | | |

Certified that test welds are prepared, welded and tested satisfactorily, in accordance with the requirements of the code/testing standard indicated above.

Location: _____ Date of issue: _____ Examiner or Examining body: _____

.....
 (Name, date and signature)

Manufacturer's welding procedure _____ Examiner or Examining body _____

Reference No.: _____ Reference No.: _____

Application ≤ 100 °C Application > 100 °C

Abbreviations (Abbreviated terms):

- uc unequal collar
- ic incomplete collar
- 201-2 · 3 2 pores of 3 mm diameter (example)
- nf no fracture
- wf fracture in weld
- sf fracture in stud
- 100 crack
- 400 lack of fusion
- no no
- objections a acceptable
- na not acceptable

NOTE Numbers 100 and 400 refer to ISO 6520-1.

1) Visual examination

Remarks: Assessment:

.....

2) Bend testing

Bend testing (application ≤ 100 °C) / bend testing by means of torque wrench (application > 100 °C)

| Specimen number | Bending angle/ bending moment Nm | Location of fracture | Remarks | Assessment |
|-----------------|--|----------------------|---------|------------|
| | | | | |
| | | | | |
| | | | | |
| | | | | |
| | | | | |
| | | | | |
| | | | | |
| | | | | |
| | | | | |
| | | | | |

3) Tensile testing (only for application ≤ 100 °C)

| Specimen number | Fracture load N | Location of fracture | Fracture strength N/mm ² | Size of imperfection area mm ² | Size of the largest imperfection mm | Remarks | Assessment |
|-----------------|------------------------|----------------------|--|--|--|---------|------------|
| | | | | | | | |
| | | | | | | | |
| | | | | | | | |
| | | | | | | | |
| | | | | | | | |
| | | | | | | | |
| | | | | | | | |
| | | | | | | | |
| | | | | | | | |
| | | | | | | | |
| | | | | | | | |

4) Radiographic examination (only for application > 100 °C, d > 12 mm)

| Specimen number | Type of imperfections | Size of imperfection area mm ² | Size of the largest imperfection mm | Remarks | Assessment |
|-----------------|-----------------------|--|--|---------|------------|
| | | | | | |
| | | | | | |
| | | | | | |
| | | | | | |
| | | | | | |

5) Macro examination

| Specimen number: | Picture number: | Magnification: | Result | Assessment | Specimen number: | Picture number: | Magnification: | Result | Assessment |
|------------------|-----------------|----------------|--------|------------|------------------|-----------------|----------------|--------|------------|
| Picture | | | | | Picture | | | | |

6) Torque test (only for short cycle drawn-arc stud welding)

| Specimen number | Torque Nm | Location of fracture | Remarks | Assessment |
|-----------------|--------------|----------------------|---------|------------|
| | | | | |
| | | | | |
| | | | | |
| | | | | |
| | | | | |
| | | | | |
| | | | | |
| | | | | |
| | | | | |
| | | | | |
| | | | | |
| | | | | |
| | | | | |

7) Additional tests

Remarks and additional steps:

.....

.....

Test carried out in accordance with the requirements of:

.....

Laboratory Report Reference No.:

Test results are acceptable/not acceptable (delete as appropriate)

Examiner or Examining body:

Test carried out in the presence of:

(Name, date and signature)

Annex E (informative)

Welding procedure qualification record form (WPQR) (for capacitor discharge stud welding with tip ignition and capacitor discharge drawn-arc stud welding)

Welding procedure qualification — Test certificate

Manufacturer: Examiner or Examining body:

Address: Code/testing standard:

Date of welding:

Manufacturer's welding procedure

Reference No.: Name of operator:

Extent of qualification

Stud-welding process: Stud diameter (mm):

Stud material: Stud length (mm):

Parent material: Stud designation:

Parent material thickness (mm):

Welding: with gap with contact

Power source:

Welding gun/head:

Other information:

.....

.....

| Capacitance mF | Charging voltage V | Gap mm | Spring force N or plunging speed mm/s | Remarks |
|-----------------------|---------------------------|---------------|--|---------|
| | | | | |

Certified that test welds are prepared, welded and tested satisfactorily, in accordance with the requirements of the code/testing standard indicated above.

Location: _____ Date of issue: _____ Examiner or Examining body: _____

.....
 (Name, date and signature)

Manufacturer's welding procedure _____ Examiner or Examining body _____

Reference No.: _____ Reference No.: _____

Abbreviations (Abbreviated terms):

| | |
|--------|---|
| us | unequal spatters |
| is | incomplete spatter ring |
| nf | no fracture |
| wf | fracture in weld |
| sf | fracture in stud |
| 400-10 | non-welded fracture area in percent (e.g. 10 %) |
| 100 | crack |
| 400 | lack of fusion |
| no | no objections |
| a | acceptable |
| na | not acceptable |

NOTE Numbers 100 and 400 refer to ISO 6520-1.

1) Visual examination

Remarks: Assessment:

.....

2) Bend testing

| Specimen number | Bending angle | Location of fracture | Remarks | Assessment |
|-----------------|---------------|----------------------|---------|------------|
| | | | | |
| | | | | |
| | | | | |
| | | | | |
| | | | | |
| | | | | |
| | | | | |
| | | | | |
| | | | | |
| | | | | |
| | | | | |
| | | | | |
| | | | | |
| | | | | |
| | | | | |
| | | | | |
| | | | | |
| | | | | |
| | | | | |
| | | | | |
| | | | | |
| | | | | |
| | | | | |

3) Tensile testing

| Specimen number | Fracture load N | Location of fracture | Fracture strength N/mm ² | Size of imperfection area mm ² | Size of the largest imperfection mm | Remarks | Assessment |
|-----------------|--------------------|----------------------|--|--|--|---------|------------|
| | | | | | | | |
| | | | | | | | |
| | | | | | | | |
| | | | | | | | |
| | | | | | | | |
| | | | | | | | |
| | | | | | | | |
| | | | | | | | |
| | | | | | | | |
| | | | | | | | |
| | | | | | | | |
| | | | | | | | |
| | | | | | | | |
| | | | | | | | |
| | | | | | | | |
| | | | | | | | |
| | | | | | | | |
| | | | | | | | |
| | | | | | | | |
| | | | | | | | |
| | | | | | | | |
| | | | | | | | |
| | | | | | | | |
| | | | | | | | |
| | | | | | | | |
| | | | | | | | |
| | | | | | | | |

4) Additional tests

Remarks and additional steps:

.....

.....

Test carried out in accordance with the requirements of:

.....

Laboratory Report Reference No.:

Test results are acceptable/not acceptable (delete as appropriate)

Examiner or Examining body:

Test carried out in the presence of:

(Name, date and signature)

Annex F (informative)

Test results — Production test (for drawn-arc stud welding with ceramic ferrule or shielding gas and short-cycle drawn-arc stud welding)

| | |
|----------------------------------|---------------------------------|
| Manufacturer's welding procedure | Welding procedure specification |
| Reference No.: | Reference No.: |
| Welding process: | Location of welding: |
| Project number: | Shop/on site: |
| | Drawing No.: |
| | Position No.: |
| Parent material: | Stud material: |
| Parent material thickness (mm): | Stud diameter (mm): |
| | Stud designation: |
| Date of test welding: | Operator: |

| Drawn arc stud welding with ceramic ferrule or shielding gas and short-cycle drawn-arc stud welding | Welding current | Welding time | Protrusion | Lift | Remarks |
|---|-----------------|--------------|------------|------|---------|
| | A | s | mm | mm | |
| | | | | | |

Abbreviations (Abbreviated terms):

| | |
|-----------|---|
| uc | unequal collar |
| ic | incomplete collar |
| 201-2 – 3 | 2 pores of 3 mm diameter (example) |
| nf | no fracture |
| wf | fracture in weld |
| sf | fracture in stud |
| 400-10 | non-welded fracture area in percent (e.g. 10 %) |
| 100 | crack |
| 400 | lack of fusion |

no no objections

a acceptable

na not acceptable

NOTE Numbers 100 and 400 refer to ISO 6520-1.

1) Visual examination

Remarks: Assessment:

.....

2) Bend testing

Bend testing/bend testing by means of a torque wrench (application > 100 °C)

| Specimen number | Bending angle/ bending moment | Location of fracture | Remarks | Assessment |
|-----------------|----------------------------------|----------------------|---------|------------|
| | | | | |
| | | | | |
| | | | | |
| | | | | |
| | | | | |
| | | | | |
| | | | | |

3) Macro examination

| Specimen number: | Picture number: | Magnification: | Result | Assessment | Specimen number: | Picture number: | Magnification: | Result | Assessment |
|------------------|-----------------|----------------|--------|------------|------------------|-----------------|----------------|--------|------------|
| Picture | | | | | Picture | | | | |

4) Additional tests

Total assessment:

.....

.....

Remarks and additional steps:

.....

.....

Test carried out in the presence of:

.....

.....

Welding coordinator:

.....

Examiner or Examining body:

.....

Locality:

.....

.....

Date:

.....

.....

(Signature of welding coordinator)

(Signature of examining body)

Annex G (informative)

Test results — Production test (for capacitor discharge stud welding with tip ignition and capacitor discharge drawn-arc stud welding)

| | |
|----------------------------------|---------------------------------|
| Manufacturer's welding procedure | Welding procedure specification |
| Reference No.: | Reference No.: |
| Welding process: | Location of welding: |
| Project number: | Shop/on site: |
| | Drawing No.: |
| | Position No.: |
| Parent material: | Stud material: |
| Parent material thickness (mm): | Stud diameter (mm): |
| | Stud designation: |
| Date of test welding: | Operator: |

| Capacitor discharge stud welding with tip ignition and capacitor discharge drawn-arc stud welding | Capacitance | Charging voltage | Gap | Spring force | Remarks |
|--|--------------------|-------------------------|------------|---------------------------------------|----------------|
| | mF | V | mm | N or plunging speed mm/s | |
| | | | | | |

Abbreviations (Abbreviated terms):

| | |
|--------|---|
| us | unequal spatters |
| is | incomplete spatter ring |
| nf | no fracture |
| wf | fracture in weld |
| sf | fracture in stud |
| 400-10 | non-welded fracture area in percent (e.g. 10 %) |
| 100 | crack |
| 400 | lack of fusion |

no no objections

a acceptable

na not acceptable

NOTE Numbers 100 and 400 refer to ISO 6520-1.

1) Visual examination

Remarks: Assessment:

.....

2) Bend testing

| Specimen number | Bending angle/ bending moment | Location of fracture | Remarks | Assessment |
|-----------------|----------------------------------|----------------------|---------|------------|
| | | | | |
| | | | | |
| | | | | |
| | | | | |
| | | | | |
| | | | | |
| | | | | |

3) Tensile testing

| Specimen number | Fracture load N | Location of fracture | Fracture strength N/mm ² | Size of imperfection area mm ² | Size of the largest imperfection n mm | Remarks | Assessment |
|-----------------|--------------------|----------------------|--|--|---|---------|------------|
| | | | | | | | |
| | | | | | | | |
| | | | | | | | |
| | | | | | | | |
| | | | | | | | |

4) Additional tests

Total assessment:
.....
.....

Remarks and additional steps:
.....
.....

Test carried out in the presence of:
.....
.....

Welding coordinator:
.....

Examiner or Examining body:
.....

Locality:
.....
.....

Date:
.....
.....

(Signature of welding coordinator)

(Signature of examining body)

Annex H
(informative)

Example of production surveillance record

| Date of welding | Shift number | Number of welds | WPS number | Project number/ drawing number/ position number | Stud diameter/ length mm | Time of test welding | Number/ Result of ring test | Number/ Result of visual examination | Number/ Result of bend test |
|-----------------|--------------|-----------------|------------|---|--------------------------------|----------------------|--------------------------------|---|--------------------------------|
| | | | | | | | | | |
| | | | | | | | | | |
| | | | | | | | | | |
| | | | | | | | | | |

Bibliography

- [1] ISO 3834-5, *Quality requirements for fusion welding of metallic materials — Part 5: Documents with which it is necessary to conform to claim conformity to the quality requirements of ISO 3834-2, ISO 3834-3 or ISO 3834-4*
- [2] ISO 5828, *Resistance welding equipment — Secondary connecting cables with terminals connected to water-cooled lugs — Dimensions and characteristics*
- [3] ISO 6520-1, *Welding and allied processes — Classification of geometric imperfections in metallic materials — Part 1: Fusion welding*
- [4] ISO/TR 20172, *Welding — Grouping systems for materials — European materials*
- [5] ISO/TR 20173, *Welding — Grouping systems for materials — American materials*
- [6] ISO/TR 20174, *Welding — Grouping systems for materials — Japanese materials*
- [7] IEC 60974-1, *Arc welding equipment — Part 1: Welding power sources*

British Standards Institution (BSI)

BSI is the national body responsible for preparing British Standards and other standards-related publications, information and services.

BSI is incorporated by Royal Charter. British Standards and other standardization products are published by BSI Standards Limited.

About us

We bring together business, industry, government, consumers, innovators and others to shape their combined experience and expertise into standards-based solutions.

The knowledge embodied in our standards has been carefully assembled in a dependable format and refined through our open consultation process. Organizations of all sizes and across all sectors choose standards to help them achieve their goals.

Information on standards

We can provide you with the knowledge that your organization needs to succeed. Find out more about British Standards by visiting our website at bsigroup.com/standards or contacting our Customer Services team or Knowledge Centre.

Buying standards

You can buy and download PDF versions of BSI publications, including British and adopted European and international standards, through our website at bsigroup.com/shop, where hard copies can also be purchased.

If you need international and foreign standards from other Standards Development Organizations, hard copies can be ordered from our Customer Services team.

Subscriptions

Our range of subscription services are designed to make using standards easier for you. For further information on our subscription products go to bsigroup.com/subscriptions.

With **British Standards Online (BSOL)** you'll have instant access to over 55,000 British and adopted European and international standards from your desktop. It's available 24/7 and is refreshed daily so you'll always be up to date.

You can keep in touch with standards developments and receive substantial discounts on the purchase price of standards, both in single copy and subscription format, by becoming a **BSI Subscribing Member**.

PLUS is an updating service exclusive to BSI Subscribing Members. You will automatically receive the latest hard copy of your standards when they're revised or replaced.

To find out more about becoming a BSI Subscribing Member and the benefits of membership, please visit bsigroup.com/shop.

With a **Multi-User Network Licence (MUNL)** you are able to host standards publications on your intranet. Licences can cover as few or as many users as you wish. With updates supplied as soon as they're available, you can be sure your documentation is current. For further information, email bsmusales@bsigroup.com.

Revisions

Our British Standards and other publications are updated by amendment or revision.

We continually improve the quality of our products and services to benefit your business. If you find an inaccuracy or ambiguity within a British Standard or other BSI publication please inform the Knowledge Centre.

Copyright

All the data, software and documentation set out in all British Standards and other BSI publications are the property of and copyrighted by BSI, or some person or entity that owns copyright in the information used (such as the international standardization bodies) and has formally licensed such information to BSI for commercial publication and use. Except as permitted under the Copyright, Designs and Patents Act 1988 no extract may be reproduced, stored in a retrieval system or transmitted in any form or by any means – electronic, photocopying, recording or otherwise – without prior written permission from BSI. Details and advice can be obtained from the Copyright & Licensing Department.

Useful Contacts:

Customer Services

Tel: +44 845 086 9001

Email (orders): orders@bsigroup.com

Email (enquiries): cservices@bsigroup.com

Subscriptions

Tel: +44 845 086 9001

Email: subscriptions@bsigroup.com

Knowledge Centre

Tel: +44 20 8996 7004

Email: knowledgecentre@bsigroup.com

Copyright & Licensing

Tel: +44 20 8996 7070

Email: copyright@bsigroup.com

BSI Group Headquarters

389 Chiswick High Road London W4 4AL UK



...making excellence a habit.™