

BS EN ISO 14451-2:2013



BSI Standards Publication

# Pyrotechnic articles — Pyrotechnic articles for vehicles

Part 2: Test methods

**bsi.**

...making excellence a habit.™

**National foreword**

This British Standard is the UK implementation of EN ISO 14451-2:2013.

The UK participation in its preparation was entrusted to Technical Committee CII/47, Pyrotechnic articles.

A list of organizations represented on this committee can be obtained on request to its secretary.

This publication does not purport to include all the necessary provisions of a contract. Users are responsible for its correct application.

© The British Standards Institution 2013.  
Published by BSI Standards Limited 2013.

ISBN 978 0 580 69663 3  
ICS 43.040.80

**Compliance with a British Standard cannot confer immunity from legal obligations.**

This British Standard was published under the authority of the Standards Policy and Strategy Committee on 31 May 2013.

**Amendments issued since publication**

Date	Text affected
------	---------------

---

ICS 43.040.80

English Version

**Pyrotechnic articles - Pyrotechnic articles for vehicles - Part 2:  
Test methods (ISO 14451-2:2013)**

Articles pyrotechniques - Articles pyrotechniques pour  
véhicules - Partie 2: Méthodes d'essai (ISO 14451-2:2013)

Pyrotechnische Gegenstände - Pyrotechnische  
Gegenstände für Fahrzeuge - Teil 2: Prüfverfahren (ISO  
14451-2:2013)

This European Standard was approved by CEN on 9 February 2013.

CEN members are bound to comply with the CEN/CENELEC Internal Regulations which stipulate the conditions for giving this European Standard the status of a national standard without any alteration. Up-to-date lists and bibliographical references concerning such national standards may be obtained on application to the CEN-CENELEC Management Centre or to any CEN member.

This European Standard exists in three official versions (English, French, German). A version in any other language made by translation under the responsibility of a CEN member into its own language and notified to the CEN-CENELEC Management Centre has the same status as the official versions.

CEN members are the national standards bodies of Austria, Belgium, Bulgaria, Croatia, Cyprus, Czech Republic, Denmark, Estonia, Finland, Former Yugoslav Republic of Macedonia, France, Germany, Greece, Hungary, Iceland, Ireland, Italy, Latvia, Lithuania, Luxembourg, Malta, Netherlands, Norway, Poland, Portugal, Romania, Slovakia, Slovenia, Spain, Sweden, Switzerland, Turkey and United Kingdom.



EUROPEAN COMMITTEE FOR STANDARDIZATION  
COMITÉ EUROPÉEN DE NORMALISATION  
EUROPÄISCHES KOMITEE FÜR NORMUNG

**Management Centre: Avenue Marnix 17, B-1000 Brussels**

## Foreword

This document (EN ISO 14451-2:2013) has been prepared by Technical Committee CEN/TC 212 "Pyrotechnic articles" the secretariat of which is held by NEN, in collaboration with Technical Committee ISO/TC 22 "Road vehicles".

This European Standard shall be given the status of a national standard, either by publication of an identical text or by endorsement, at the latest by September 2013, and conflicting national standards shall be withdrawn at the latest by September 2013.

Attention is drawn to the possibility that some of the elements of this document may be the subject of patent rights. CEN [and/or CENELEC] shall not be held responsible for identifying any or all such patent rights.

This document has been prepared under a mandate given to CEN by the European Commission and the European Free Trade Association, and supports essential requirements of EU Directive.

For relationship with EU Directive, see informative Annex ZA, which is an integral part of this document.

According to the CEN-CENELEC Internal Regulations, the national standards organizations of the following countries are bound to implement this European Standard: Austria, Belgium, Bulgaria, Croatia, Cyprus, Czech Republic, Denmark, Estonia, Finland, Former Yugoslav Republic of Macedonia, France, Germany, Greece, Hungary, Iceland, Ireland, Italy, Latvia, Lithuania, Luxembourg, Malta, Netherlands, Norway, Poland, Portugal, Romania, Slovakia, Slovenia, Spain, Sweden, Switzerland, Turkey and the United Kingdom.

### Endorsement notice

The text of ISO 14451-2:2013 has been approved by CEN as EN ISO 14451-2:2013 without any modification.

## Annex ZA (informative)

### Relationship between this European Standard and the Essential Requirements of EC Directive 2007/23/EC on the placing on the market of pyrotechnic articles

This European Standard has been prepared under a mandate given to CEN by the European Commission and the European Free Trade Association to provide one means of conforming to Essential Requirements of the New Approach Directive 2007/23/EC on the placing on the market of pyrotechnic articles.

Once this standard is cited in the Official Journal of the European Union under that Directive and has been implemented as a national standard in at least one Member State, compliance with the normative clauses of this standard given in Table ZA.1 confers, within the limits of the scope of this standard, a presumption of conformity with the corresponding Essential Requirements of that Directive and associated EFTA regulations.

**Table ZA.1 — Correspondence between this European Standard and Directive 2007/23/EC on the placing on the market of pyrotechnic articles (1 of 2)**

Clause(s)/sub-clause(s) of this document	Essential Safety Requirements (ESRs) of Directive 2007/23/EC	Qualifying remarks/Notes
4.7, 4.8, 4.9	(1)	Note: It is taken into account that the intended purpose of the pyrotechnic article is to function in a vehicle in case of accidents
4.1	(2)	Reference: Directive 2000/53/EC
4.9	(3) 1st sentence	
4.9	(3) 2nd and 3rd sentences	Note: It is taken into account that the intended purpose of the pyrotechnic article is to function in a vehicle in case of accidents
4.1	(3a)	
4.3, 4.4	(3b)	
4.2, 4.3, 4.5	(3c)	
4.4	(3d)	
4.4	(3e)	
4.3, 4.4	(3f)	
4.5	(3g)	
4.1	(3h)	See also ISO 14451-3
4.2	(3i)	

Table ZA.1 — (2 of 2)

Clause(s)/sub-clause(s) of this document	Essential Safety Requirements (ESRs) of Directive 2007/23/EC	Qualifying remarks/Notes
4.1	(3j)	
4.2, 4.3, 4.5	(3) Last sentence	
4.1	(4a)	
4.1	(4b)	
4.1, 4.9	(5 B.1)	
4.1	(5 B.2)	
4.5, 4.6	(5 B.3)	
	(5 B.4)	Not applicable
4.7	(5 C.1)	
4.5	(5 C.2)	
4.5	(5 C.3)	
	(5 C.4)	Not applicable
	(5 C.5)	Not applicable
4.1	(5 C.6)	
4.5	(5 C.7)	

**WARNING — Other requirements and other EU Directives may be applicable to the product(s) falling within the scope of this part of EN ISO 14451.**

# Contents

Page

<b>Foreword</b> .....	<b>iv</b>
<b>1 Scope</b> .....	<b>1</b>
<b>2 Normative references</b> .....	<b>1</b>
<b>3 Terms and definitions</b> .....	<b>1</b>
<b>4 Test methods</b> .....	<b>1</b>
4.1 Verification of design and documentation.....	1
4.2 Drop test.....	2
4.3 Vibration and temperature test.....	3
4.4 Thermal humidity cycling test.....	5
4.5 Electrostatic discharge (ESD) test.....	6
4.6 Fire test.....	10
4.7 Igniter test.....	12
4.8 Tank test.....	12
4.9 Functioning test.....	13
<b>5 Recording</b> .....	<b>13</b>
<b>Annex A (normative) Definition of temperature build-up time, <math>t_e</math></b> .....	<b>14</b>
<b>Annex B (normative) Probit test (PBBS test)</b> .....	<b>16</b>
<b>Annex C (normative) Bruceton method</b> .....	<b>22</b>
<b>Bibliography</b> .....	<b>25</b>

## Foreword

ISO (the International Organization for Standardization) is a worldwide federation of national standards bodies (ISO member bodies). The work of preparing International Standards is normally carried out through ISO technical committees. Each member body interested in a subject for which a technical committee has been established has the right to be represented on that committee. International organizations, governmental and non-governmental, in liaison with ISO, also take part in the work. ISO collaborates closely with the International Electrotechnical Commission (IEC) on all matters of electrotechnical standardization.

International Standards are drafted in accordance with the rules given in the ISO/IEC Directives, Part 2.

The main task of technical committees is to prepare International Standards. Draft International Standards adopted by the technical committees are circulated to the member bodies for voting. Publication as an International Standard requires approval by at least 75 % of the member bodies casting a vote.

Attention is drawn to the possibility that some of the elements of this document may be the subject of patent rights. ISO shall not be held responsible for identifying any or all such patent rights.

ISO 14451-2 was prepared by the European Committee for Standardization (CEN) Technical Committee CEN/TC 212, *Pyrotechnic articles*, in collaboration with Technical Committee ISO/TC 22, *Road vehicles*, Subcommittee SC 12, *Passive safety crash protection systems*, in accordance with the Agreement on technical cooperation between ISO and CEN (Vienna Agreement).

ISO 14451 consists of the following parts, under the general title *Pyrotechnic articles — Pyrotechnic articles for vehicles*:

- *Part 1: Terminology*
- *Part 2: Test methods*
- *Part 3: Labelling*
- *Part 4: Requirements and categorization for micro gas generators*
- *Part 5: Requirements and categorization for airbag gas generators*
- *Part 6: Requirements and categorization for airbag modules*
- *Part 7: Requirements and categorization for seatbelt pretensioners*
- *Part 8: Requirements and categorization for igniters*
- *Part 9: Requirements and categorization for actuators*
- *Part 10: Requirements and categorization for semi-finished products*



# Pyrotechnic articles — Pyrotechnic articles for vehicles —

## Part 2: Test methods

### 1 Scope

This part of ISO 14451 establishes uniform test methods for pyrotechnic articles for vehicles.

### 2 Normative references

The following referenced documents are indispensable for the application of this document. For dated references, only the edition cited applies. For undated references, the latest edition of the referenced document (including any amendments) applies.

ISO 14451-1, *Pyrotechnic articles — Pyrotechnic articles for vehicles — Part 1: Terminology*

ISO 14451-3, *Pyrotechnic articles — Pyrotechnic articles for vehicles — Part 3: Labelling*

ISO 14451-5, *Pyrotechnic articles — Pyrotechnic articles for vehicles — Part 5: Requirements and categorization for airbag gas generators*

ISO 14451-6, *Pyrotechnic articles — Pyrotechnic articles for vehicles — Part 6: Requirements and categorization for airbag modules*

ISO 14451-7, *Pyrotechnic articles — Pyrotechnic articles for vehicles — Part 7: Requirements and categorization for seatbelt pretensioners*

ISO 14451-9, *Pyrotechnic articles — Pyrotechnic articles for vehicles — Part 9: Requirements and categorization for actuators*

### 3 Terms and definitions

For the purposes of this document, the terms and definitions given in ISO 14451-1 apply.

NOTE Wherever reference is made to *pyrotechnic article(s)* only *pyrotechnic articles for vehicles* are meant.

### 4 Test methods

#### 4.1 Verification of design and documentation

The manufacturer shall supply a document which describes the pyrotechnic article. The typical content of the document shall include the following information:

- description of the purpose of the pyrotechnic article;
- sketch with external dimensions;
- total mass of the pyrotechnic article;
- cross section and part list;
- mass and pyrotechnic composition(s) contained in the article;

- description of intended behaviour;
- description of foreseeable behaviour during fire test if applicable;
- proposed labelling in accordance with ISO 14451-3;
- safety data sheet/handling instructions, including electrical characteristics (e.g. all-fire current, no-fire current, resistance, etc.) which shall be provided with the pyrotechnic article.

This shall be verified by visual inspection by the naked eye.

## 4.2 Drop test

### 4.2.1 Purpose

The purpose of this test is to determine whether the pyrotechnic article experiences any detrimental effect when dropped from a specified height and at specified orientations.

### 4.2.2 Equipment

A steel impact plate of a minimum of 1 m x 1 m with at least 10 mm thickness, resting on a solid floor, with a fixture that supports the pyrotechnic article at the specified height, shall be used.

### 4.2.3 Test conditions

The drop height shall be  $1^{+0,2}_0$  m.

The test shall be done with the pyrotechnic article at ambient temperature.

### 4.2.4 Test procedure

Mount one pyrotechnic article into the support fixture at the specified height above the impact plate and oriented such that it will fall in one of the six directions indicated in [Figure 1](#). Disarm the trigger device, if included in the pyrotechnic article.

Release the pyrotechnic article, allowing it to free fall onto the impact plate. Repeat the test using the same pyrotechnic article oriented to fall in the opposite direction.

Repeat the test twice more, once using a second pyrotechnic article and once using a third pyrotechnic article, each time along one of the remaining directions indicated in [Figure 1](#).

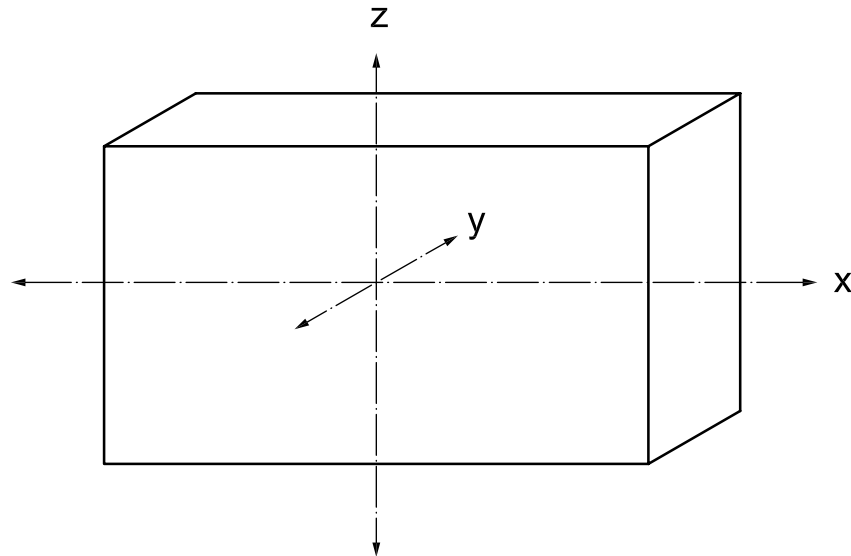

Figure 1 — Definition of main axes

### 4.3 Vibration and temperature test

#### 4.3.1 Purpose

The purpose of this test is to determine the ability of the pyrotechnic article to withstand vibration and temperature conditions. The test may be performed simultaneously or sequentially.

#### 4.3.2 Equipment

The equipment shall consist of a vibration table capable of producing the vibration loads as characterized in [Figure 2](#) and a climatic chamber capable of controlling the temperature during the test in accordance with [Figure 3](#). In case the test is being performed simultaneously the vibration table shall be mounted within the climatic chamber.

#### 4.3.3 Test conditions

The temperature tolerance shall be  $\pm 2,5$  °C.

#### 4.3.4 Test procedure

Fix the pyrotechnic article to the vibration table by an appropriate method insuring correct transmission of the vibration load. Apply random vibration in accordance with [Table 1](#) and [Figure 2](#) along each of the three main axes (see [Figure 1](#)) of each pyrotechnic article for 24 h.

Place the pyrotechnic article in the climatic chamber. The temperature shall be changed in accordance with [Figure 3](#). It may be changed simultaneously with application of the vibration load.

**Table 1 — Frequency characteristics at RMS of 1,34 g**

Frequency Hz	Power spectral density $g^2/Hz$
8	0,035
50	0,035
80	0,001
200	0,000 5

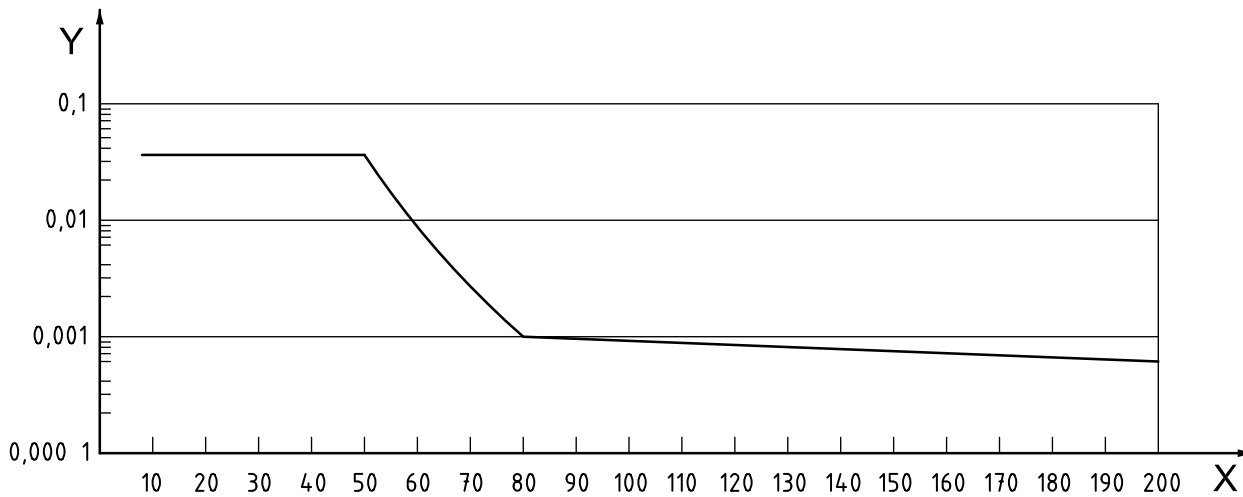

**Key**

X frequency, expressed in hertz

Y power spectral density, expressed in  $g^2$  per hertz

**Figure 2 — Vibration test**

Note to Figure 2: Number of lines: 400; Range of analysis (filter bandwidth 1,25 Hz): 500 Hz; Degree of freedom (DOF): 154; Abort limits lines:  $\pm 5$  dB; Abort limits  $g$  RMS:  $\pm 5$  dB.

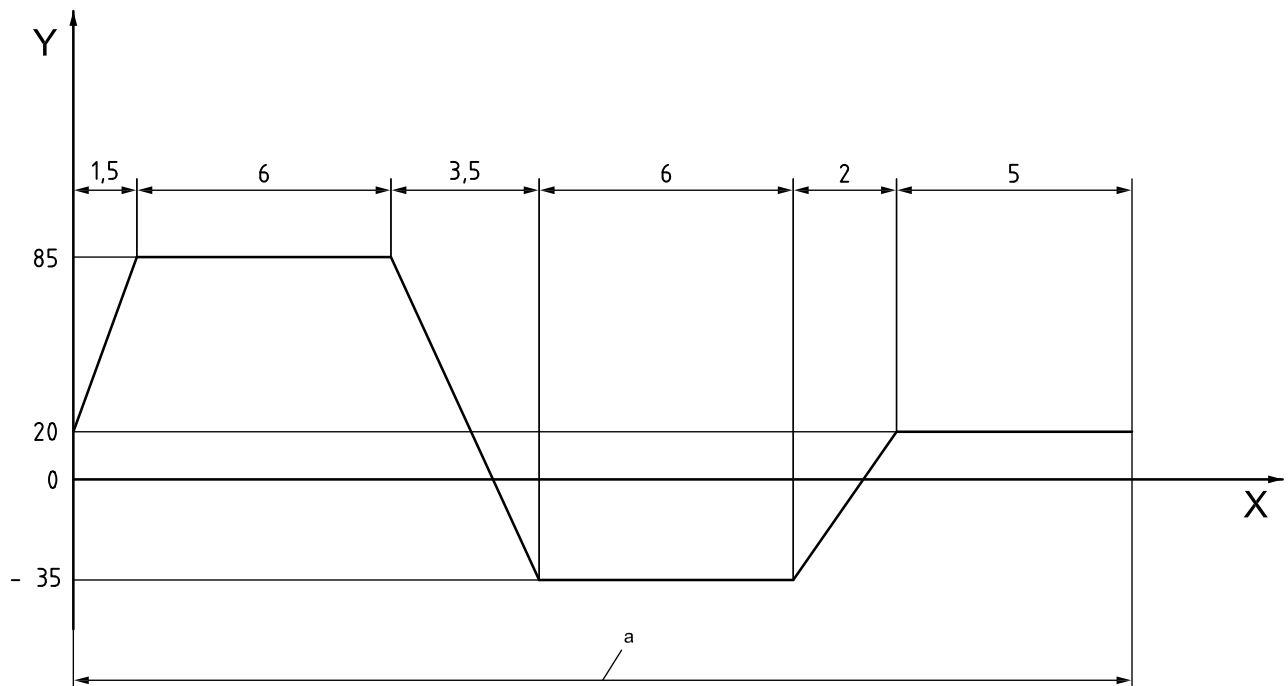

**Key**

- X time, expressed in hours
- Y temperature, expressed in degrees Celsius
- a Duration of one cycle: 24h

**Figure 3 — Temperature cycle**

**4.4 Thermal humidity cycling test**

**4.4.1 Purpose**

The purpose of this test is to determine the ability of the pyrotechnic article to withstand high humidity and temperature variations.

**4.4.2 Equipment**

A climatic chamber with recirculating air shall be used.

**4.4.3 Test condition**

The temperature tolerance shall be  $\pm 2,5$  °C.

**4.4.4 Test procedure**

Place the pyrotechnic article in the climatic chamber and subject it to 30 thermal humidity cycles in accordance with [Figure 4](#).

NOTE 1 The temperature reference point is within the propelling media.

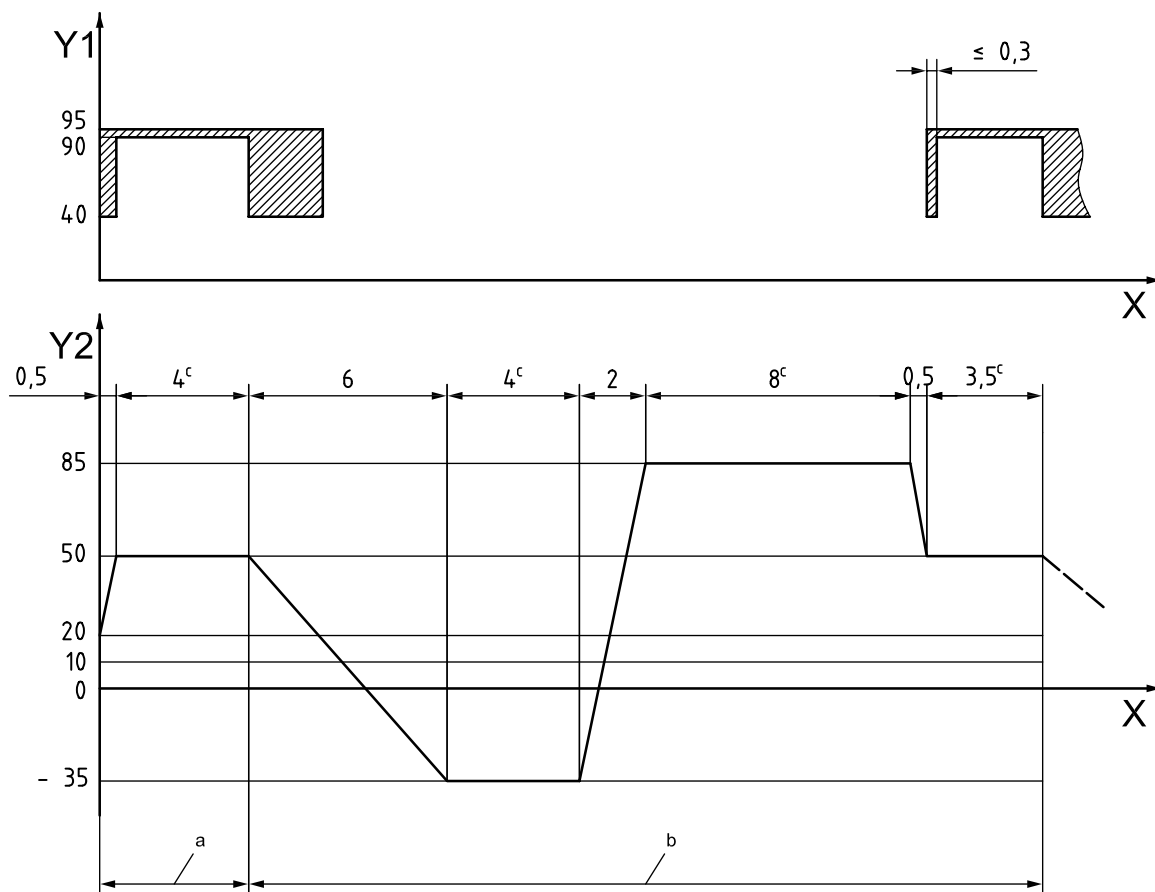

- |                |  |   |   |
|----------------|--|---|---|
| X              | time, expressed in hours                         | a | Lead time   |
| Y <sub>1</sub> | relative air humidity, expressed as a percentage | b | Duration of one cycle: 24h, or less using $t_e$ . |
| Y <sub>2</sub> | temperature, expressed in degrees Celsius        | c | Or: reference temperature build-up time, $t_e$ .  |

NOTE 2 The relevant temperature build-up times,  $t_e$ , may be used instead of the given hours; if  $t_e$  is used, it shall be determined prior to the test according to the procedure in [Annex A](#).

**Figure 4 — Thermal humidity cycle**

## 4.5 Electrostatic discharge (ESD) test

### 4.5.1 Purpose

The purpose of this test is to prove the ability of the pyrotechnic article to withstand electrostatic discharges without unintended ignition.

### 4.5.2 Equipment

An ESD generator capable of producing the test pulse, adjustable within the limits given in [4.5.3](#), shall be used consisting in its main parts of the following and meeting the respective requirements:

- charging resistor: resistance,  $R_{ch}$ , between 50 M $\Omega$  and 100 M $\Omega$ ;
- energy-storage capacitor: capacitance,  $C_s$ ; ( $C_s + C_d$ ) 150 pF  $\pm$  10 %;
- distributed capacitance,  $C_d$ ;

- hand capacitor: capacitance,  $C_h$  of  $10 \text{ pF} \pm 10 \%$ ;
- discharge resistor: resistance,  $R_d$ , of  $330 \Omega \pm 10 \%$ ;
- voltage indicator: tolerance of the output voltage indication,  $\pm 5 \%$ ;
- output voltage (see Note 1 of [Figure 5](#)), up to 8 kV (nominal) for contact discharge;
- polarity of the output voltage: positive and negative;
- discharge switch;
- discharge return cable;
- holding time: at least 5 s;
- discharge, mode of operation: single discharge; the generator should be able to generate at a rate of at least 20 discharges per second for exploratory purposes only;
- time between successive discharges: at least 1 s;
- power supply unit.

NOTE Open circuit voltage is measured at the energy storage capacitor.

The generator shall be provided with a means of preventing unintended radiated or conducted emissions, of either pulse or continuous type, so that the pyrotechnic article and auxiliary test equipment are not disturbed by these effects.

The discharge return cable of the test generator shall be constructed to allow the generator to meet the waveform specification. It shall be sufficiently insulated to prevent the flow, during the ESD test, of the discharge current to personnel or conducting surfaces other than via its termination.

[Figure 5](#) presents a simplified diagram of the ESD generator. Construction details are not given.

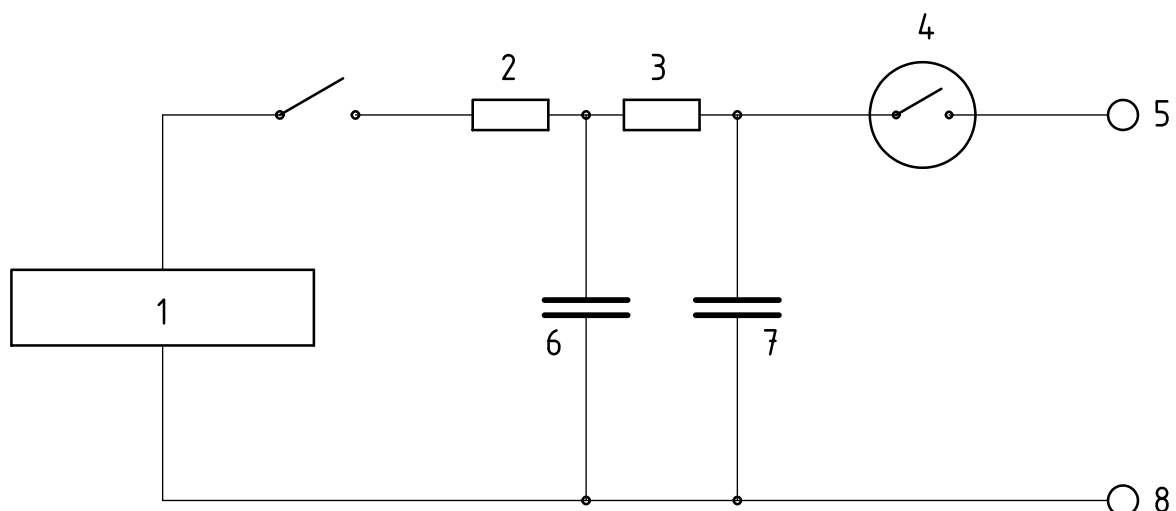

**Key**

- |                                  |                                      |
|----------------------------------|--------------------------------------|
| 1 DC HV supply                   | 5 discharge contact                  |
| 2 charging resistor ( $R_{ch}$ ) | 6 energy-storage capacitor ( $C_s$ ) |
| 3 discharge resistor ( $R_d$ )   | 7 hand capacitor ( $C_h$ )           |
| 4 discharge switch               | 8 discharge return connection        |

NOTE 1  $C_d$ , omitted from [Figure 5](#), is a distributed capacitance existing between generator and the pyrotechnic article, ground reference planes and coupling planes.

NOTE 2 Because the capacitance is distributed over the whole generator, it is not possible to show this in the circuit.

### Figure 5 — Simplified diagram of the ESD generator

#### 4.5.3 Test conditions

##### 4.5.3.1 General

The pyrotechnic article shall be at ambient temperature.

##### 4.5.3.2 Calibration of the test set-up for contact discharge

The calibration shall be done in such a way that the impulse shown in [Figure 6](#) and given in [Table 2](#) is measured by a suitable device connected to the ESD-simulator in accordance with the wiring diagram in [Figure 7](#).

The values of the parameters of the discharge current shall be verified with 1 000 MHz bandwidth-measuring instrumentation.

A lower bandwidth implies limitations in the measurement of rise time and amplitude of the first current peak.

#### 4.5.4 Test procedure

Electrostatic discharge shall be applied in accordance with [Figure 6](#).

Place the pyrotechnic article under test on a conductive bench.

The bench ESD simulator and power source shall be grounded to earth.

Identify specific test points on the pyrotechnic article prior to conducting the test.

If an igniter is present, apply the discharge to the igniter from pin to pin and from each pin to all those other areas of the casing accessible to personnel in normal use.

Perform the test with contact discharges and with positive and negative voltages. Subject each discharge point to a minimum of three positive and three negative discharges at the voltage level as shown in [Figure 6](#). The time duration between discharges shall be at least 5 s.



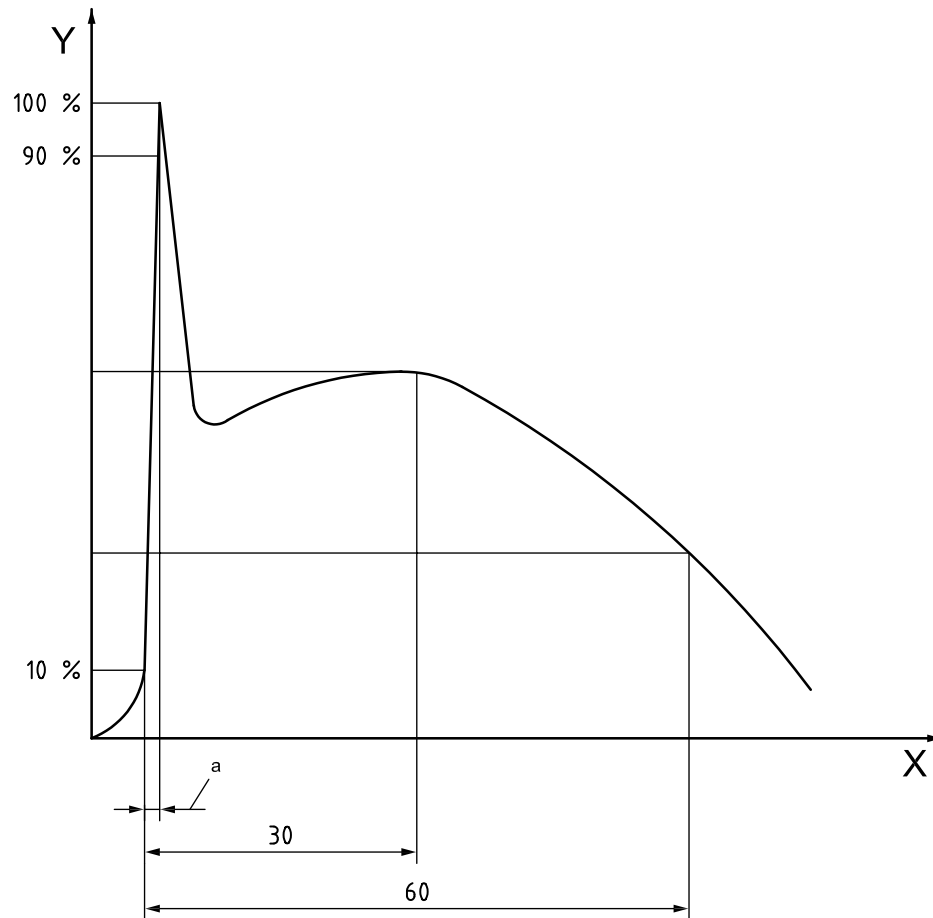

**Key**

- X time, expressed in nanoseconds
- Y current intensity, expressed in amperes
- a Risetime,  $t_r$ , with discharge switch

**Figure 6 — Typical waveform of the output current of the ESD generator**

**Table 2 — Characteristics of output current of ESD generator**

Indicated voltage	First peak current of discharge $\pm 10\%$	Rise time, $t_r$ , with discharge switch	Current ( $\pm 30\%$ ) at 30 ns	Current ( $\pm 30\%$ ) at 60 ns
8 kV	30 A	0,7 to 1 ns	16 A	8 A

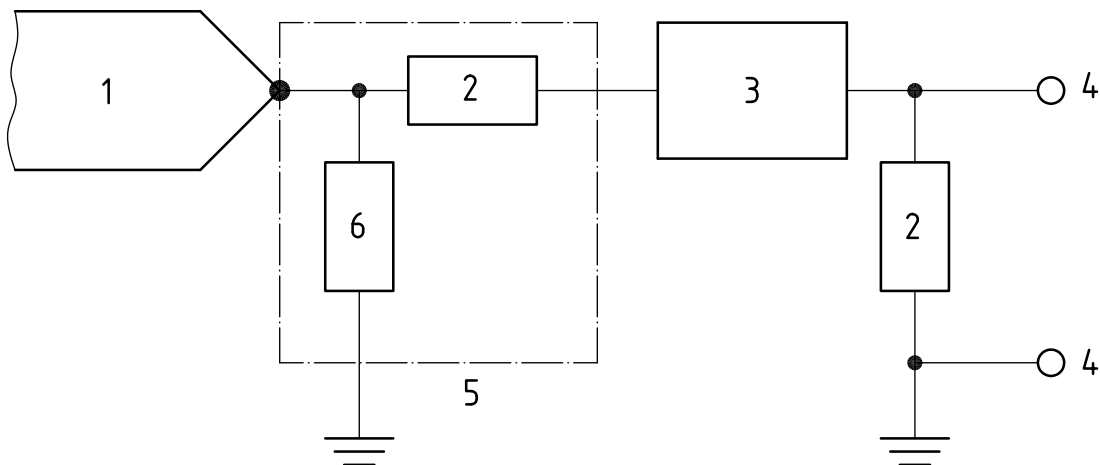

**Key**

1	ESD simulator (330 Ω)	4	purpose input
2	50 Ω	5	coaxial target
3	20 dB attenuator	6	2 Ω

**Figure 7 — ESD simulator calibration set-up schematic**

## 4.6 Fire test

### 4.6.1 Purpose

The purpose of this test is to determine the behaviour of the pyrotechnic article when exposed to fire.

### 4.6.2 Equipment

The following equipment shall be used when carrying out a fire test:

- gas cylinder, containing, for example, propane gas with gas-cylinder valve and hose assembly;
- gas burner(s), 60 mm in diameter;
- support made of mild steel according to [Figure 8](#);
- grid, an expanded metal made of mild steel as specified in [Figure 9](#) that shall cover the entire support surface;
- gas lighter;
- stop watch.

The vertical distance between mouth of the burner(s) and top of the grid shall be 400 ±10 mm.

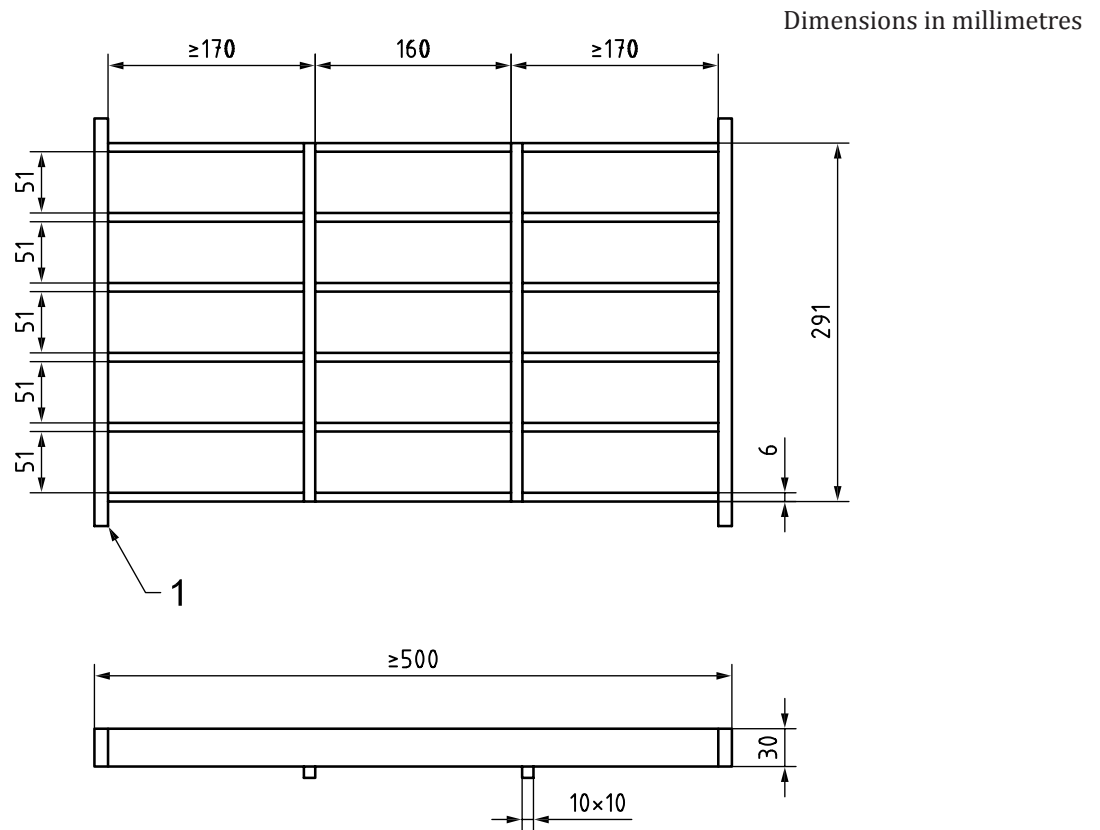

**Key**

1 fixture for user

**Figure 8 — Support**

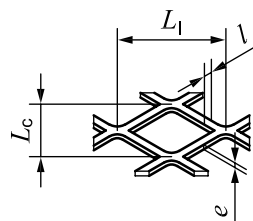

**Key**

$L_1$  long diagonal length, equal to 43 mm  
 $L_c$  short diagonal length, equal to 13 mm  
 $l$  strip width, equal to 2 mm  
 $e$  thickness, equal to 2 mm

**Figure 9 — Grid**

**4.6.3 Test conditions**

**4.6.3.1 General**

The test shall be performed with the pyrotechnic article at ambient temperature. Standard positions and heating rate of the pyrotechnic article shall be considered according to the requirement specified in ISO 14451-5, ISO 14451-6, ISO 14451-7 or ISO 14451-9.

The number of burner(s) shall be chosen such that the whole cross-section of the pyrotechnic article (projection to the grid) shall be completely engulfed in the flames.

The pyrotechnic article shall be fixed to the grid during the test by an appropriate method (e.g. hose clamps, clamps, etc.) to ensure very low thermal loss through fixation contacts.

Each pyrotechnic article shall be filmed during the test with a minimum of 25 frames per second. Each test shall be recorded.

#### **4.6.3.2 Calibration of the fire test set-up**

Calibration as described below shall be ensured for each individual burner while all burners being used for the test are ignited.

For calibration of the test installation, the heating rate shall be measured with a steel cube of 50 mm side length made of mild steel and with a mass of  $975 \text{ g} \pm 10 \text{ g}$ . The cube shall be placed on the grid (as described in 4.6.2) so that heat losses through fixation contact are minimized. A hole with diameter of maximum 3 mm and 25 mm depth to accommodate the thermocouple shall be machined in the centre of one face. The diameter at the bottom of the hole shall be adjusted to fit the thermocouple as to allow good heat contact.

The calibration shall take place between 50 °C and 200 °C with the heating rate as defined for each individual article in ISO 14451-5, ISO 14451-6, ISO 14451-7 and ISO 14451-9. The tolerance for the heat rate is  $\pm 5 \text{ K/min}$ . Maintain the testing conditions constant (especially gas flow rate and possible air movement) in order to guarantee that the pyrotechnic article experiences the same heating rate as set during calibration.

This calibration shall be repeated prior to each test series in order to guarantee constant heating rate and the calibration shall be documented.

#### **4.6.4 Test procedure**

Position the pyrotechnic article in the intended path of the fire before lighting. Heat the pyrotechnic article until all pyrotechnic content is consumed or for a time period of 20 min when no further reaction has been observed.

### **4.7 Igniter test**

#### **4.7.1 Purpose**

The purpose of this test is to establish the function and reliability of the igniter using appropriate statistical tests.

#### **4.7.2 Test procedure**

For an electrical igniter, the Probit Bayes test (see [Annex B](#))<sup>[1]</sup> or the Bruceton test (see [Annex C](#))<sup>[1]</sup> shall be used.

The test procedure proves the all-fire and no-fire values. These values, together with reliability and confidence levels, shall be specified.

### **4.8 Tank test**

#### **4.8.1 Purpose**

The purpose of this test is to assess the performance of the pyrotechnic article by firing it into a closed volume container at a given temperature level.

#### **4.8.2 Equipment**

A tank suited to the performance of the pyrotechnic article shall be used.

#### **4.8.3 Test conditions**

Each pyrotechnic article shall be tested at ambient temperature.

#### **4.8.4 Test procedure**

##### **4.8.4.1 General**

The pyrotechnic article tightly fixed to the appropriate tank shall, if applicable, be ignited with a pulse not lower than the all-fire value.

##### **4.8.4.2 Electrical connection**

Measure the igniter resistance to ensure electrical connection before ignition of the pyrotechnic article.

##### **4.8.4.3 Tank pressure**

Measure the tank pressure versus time, using a pressure transducer with the following specifications:

- appropriate calibration range;
- linearity and hysteresis error  $\leq 1\%$ .

Do not place the pressure transducer in the direct gas flow from the exit ports of the pyrotechnic article.

#### **4.9 Functioning test**

##### **4.9.1 Purpose**

The purpose of this test is to assess the behaviour of the pyrotechnic article by firing it without fixation into an open air volume.

##### **4.9.2 Test conditions**

Each pyrotechnic article shall be tested at ambient temperature.

Each pyrotechnic article shall be filmed during the test by a camera with a minimum of 25 frames per second.

##### **4.9.3 Test procedure**

The pyrotechnic article shall be ignited with a pulse not lower than the all-fire value.

### **5 Recording**

All measured parameters in tests under [Clause 4](#) shall be recorded.

## Annex A (normative)

### Definition of temperature build-up time, $t_e$

The temperature build-up time  $t_e$  is the time required, after a change in the surrounding temperature from  $T_1$  to  $T_2$ , for a defined reference point of the test sample to reach the temperature  $T_2$ , as follows:

- within 3°C, in the case of  $|T_2 - T_1| \geq 60$  °C;
- within 5 % of the temperature difference  $|T_2 - T_1|$ , in the case of  $|T_2 - T_1| < 60$  °C.

The temperature build-up time begins at the point where the desired target value curve reaches the surrounding temperature  $T_2$  (see Figure A.1 and A.2). The temperature build-up times shall be determined in the apparatus for the relevant test. The test sample temperature shall be measured at the prescribed reference point.

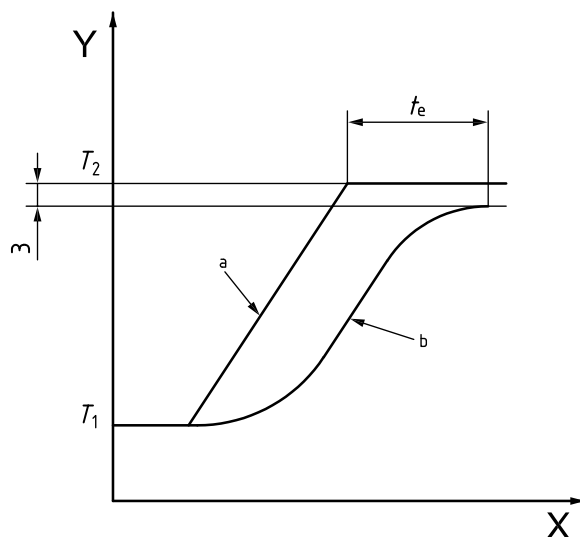

#### Key

- X time, expressed in hours  
Y temperature, expressed in degrees Celsius  
a Target temperature,  $T_{\text{targ}}$   
b Actual temperature,  $T_{\text{act}}$

Figure A.1 — Temperature build-up time  $t_e$  for  $|T_2 - T_1| \geq 60$  °C

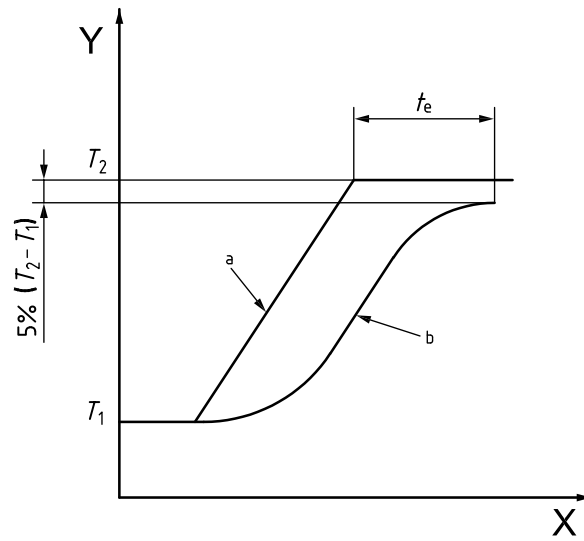

**Key**

- X time, expressed in hours
- Y temperature, expressed in degrees Celsius
- a Target temperature,  $T_{\text{targ}}$
- b Actual temperature,  $T_{\text{act}}$

**Figure A.2 — Temperature build-up time  $t_e$  for  $|T_2 - T_1| < 60 \text{ }^\circ\text{C}$**

## Annex B (normative)

### Probit test (PBBS test)

#### B.1 General

The aim of this annex is to describe the statistical model used to estimate the value of a specific quantity with a probability level of “no-fire” equal to 0,01 % and of “all-fire” equal to 99,99 %, within a confidence interval equal to 95 %. Typical estimated quantities are fire currents and fire impulses.

#### B.2 Symbols

$F^{-1}$	inverse $F$ -distribution function
$i_k$	number of fires at test level $y_k$
$K$	number of test levels
$k$	index of test levels
$N$	number of tests per test level
$p_k$	relative frequency of fire at test level $k$
$y$	tested quantity
$y_k$	value of the tested quantity at test level $k$
$y_{0,000\ 1}$	estimated value of the no-fire quantity with a probability $\beta_{NF}$ equal to 0,01 %
$y_{0,999\ 9}$	estimated value of the all-fire quantity with a probability $\beta_{AF}$ equal to 99,99 %
$y_{AF}$	$y_{0,999\ 9}$ with a confidence interval $\alpha$
$y_{NF}$	$y_{0,000\ 1}$ with a confidence interval $\alpha$
$\alpha$	required confidence interval for the all- or no-fire quantity (in this calculation, $\alpha$ is equal to 95 %)
$\beta_{AF}$	required probability of the all-fire quantity (in this calculation, $\beta_{AF}$ is equal to 99,99 %)
$\beta_{NF}$	required probability of the no-fire quantity (in this calculation, $\beta_{NF}$ is equal to 0,01 %)
$\Phi^{-1}$	inverse standard normal distribution function
$\varphi_k$	values of the inverse standard normal distribution $\Phi^{-1}$ for the frequency $p_k$
$\varphi_{AF}$	value of the inverse standard normal distribution for the probability $\beta_{AF}$ ( $\varphi_{AF} = 3,719\ 1$ )
$\varphi_{NF}$	value of the inverse standard normal distribution for the probability $\beta_{NF}$ ( $\varphi_{NF} = -3,719\ 1$ )



### B.3 Calculation of the frequencies

The relative frequency,  $p_k$ , is estimated by the general Formula (B.1):

$$p_k = \frac{i_k}{N} \quad (\text{B.1})$$

Difficulties arise when the value of the frequency is 0 or 1, i.e. when the number of occurrences at test level  $y_k$  is equal to 0 or  $N$ . In these cases, the corresponding values for  $\varphi_k$  are theoretically equal to  $-\infty$  or to  $+\infty$ . Appropriate values of  $\varphi_k$  are in these cases estimate by using the Bayes estimator as follows.

Let the test level values,  $y_k$ , be ordered such that:  $y_1 < y_2 \dots \dots \dots < y_K$

Let  $u$  be the smallest index such that  $i_u > 0$  and  $o$  be the largest index such that all  $i_o < N$ . Calculate the frequency  $p_k$  in the interval  $u \leq k \leq o$  using the set of equations given in Formulae (B.2):

$$p_k = \frac{1}{N} \times i_k \quad \text{if } i_k \neq 0 \text{ and } N$$

$$p_k = \frac{1}{N+2} \quad \text{if } i_k = 0$$
(B.2)

$$p_k = \frac{N+1}{N+2} \quad \text{if } i_k = N$$

When  $u > 1$ , calculate  $p_{u-1}$  from Formula (B.3):

$$p_{u-1} = 1 - \frac{(N+1) \left[ 1 - (1-p_u)^{N+2} \right]}{(N+2) \left[ 1 - (1-p_u)^{N+1} \right]}$$
(B.3)

When  $o < K$ , calculate  $p_{o+1}$  from Formula (B.4):

$$p_{o+1} = \frac{(N+1) \left( 1 - p_o^{N+2} \right)}{(N+2) \left( 1 - p_o^{N+1} \right)}$$
(B.4)

If  $u-1 > 1$  or  $o+1 < K$  still holds, repeat the procedure, that is, according to Formulae (B.5) and (B.6):

$$p_{u-2} = 1 - \frac{(N+1) \left[ 1 - (1-p_{u-1})^{N+2} \right]}{(N+2) \left[ 1 - (1-p_{u-1})^{N+1} \right]}$$
(B.5)

or

$$p_{o+2} = \frac{(N+1) \left( 1 - p_{o+1}^{N+2} \right)}{(N+2) \left( 1 - p_{o+1}^{N+1} \right)}$$
(B.6)

and so forth.

### B.4 Calculation of intermediate statistical parameters

The following equations apply:

$$\bar{\varphi} = \frac{\sum_{k=1}^K \varphi_k}{K}$$
(B.7)

$$\bar{y} = \frac{\sum_{k=1}^K y_k}{K} \quad (\text{B.8})$$

$$S_{yy} = \frac{\sum_{k=1}^K (y_k - \bar{y})^2}{K - 1} \quad (\text{B.9})$$

$$S_{\varphi\varphi} = \frac{\sum_{k=1}^K (\varphi_k - \bar{\varphi})^2}{K - 1} \quad (\text{B.10})$$

$$S_{\varphi y} = \frac{\sum_{k=1}^K (\varphi_k - \bar{\varphi}) \times (y_k - \bar{y})}{K - 1} \quad (\text{B.11})$$

$$D = (K - 1) \times \left( S_{\varphi\varphi} - \frac{S_{\varphi y}^2}{S_{yy}} \right) \quad (\text{B.12})$$

$$h(y) = \frac{1}{K} + \frac{(y - \bar{y})^2}{(K - 1) \times S_{yy}} \quad (\text{B.13})$$

$$\delta = \frac{2 \cdot D}{K - 2} \times F^{-1}(1 - \alpha, 2, K - 2) \quad (\text{B.14})$$

$$A = \frac{S_{\varphi y}^2}{S_{yy}^2} - \frac{\delta}{(K - 1) \times S_{yy}} \quad (\text{B.15})$$

$$B_{\text{AF}} = \frac{S_{\varphi y}}{S_{yy}} \times (\bar{\varphi} - \varphi_{\text{AF}}) \quad (\text{B.16})$$

$$B_{\text{NF}} = \frac{S_{\varphi y}}{S_{yy}} \times (\bar{\varphi} - \varphi_{\text{NF}}) \quad (\text{B.17})$$

$$C_{\text{AF}} = (\bar{\varphi} - \varphi_{\text{AF}})^2 - \frac{\delta}{K} \quad (\text{B.18})$$

$$C_{\text{NF}} = (\bar{\varphi} - \varphi_{\text{NF}})^2 - \frac{\delta}{K} \quad (\text{B.19})$$

## B.5 Calculation of the no-fire and all-fire values

The theoretical model gives Formula (B.20):

$$\varphi = \Phi^{-1}(p) = ay + b \quad (\text{B.20})$$

where the parameters  $a$  and  $b$  are estimated by

$$a = \frac{S_{\varphi y}}{S_{yy}} \quad (\text{B.21})$$

$$b = \bar{\varphi} - a\bar{y} \quad (\text{B.22})$$

From these values, the mean and the standard deviation of the underlying normal distribution may be calculated:

$$m = -\frac{b}{a} = \bar{y} - \frac{S_{yy}}{S_{\varphi y}} \times \bar{\varphi} \quad (\text{B.23})$$

$$s = \frac{S_{yy}}{S_{\varphi y}} \quad (\text{B.24})$$

The following functions are obtained as limiting curves for the corresponding confidence interval:

$$ay + b \pm [h(y) \times \delta]^{1/2}$$

and using Formula (B.22):

$$a(y - \bar{y}) + \bar{\varphi} \pm [h(y) \times \delta]^{1/2} \quad (\text{B.25})$$

Estimate the no-fire and all-fire values by solving the following quadratic equation, respectively:

$$a(y - \bar{y}) + \bar{\varphi} \pm [h(y) \times \delta]^{1/2} = \varphi_{\text{NF}} = -3,719 \ 1 \quad (\text{B.26})$$

$$a(y - \bar{y}) + \bar{\varphi} \pm [h(y) \times \delta]^{1/2} = \varphi_{\text{AF}} = -3,719 \ 1 \quad (\text{B.27})$$

From Formulae (B.21) and (B.22), calculate the values  $y_{0,000 \ 1}$  and  $y_{0,999 \ 9}$  from Formulae (B.28) and (B.29):

$$y_{0,000 \ 1} = \frac{\varphi_{\text{NF}} - b}{a} \quad (\text{B.28})$$

$$y_{0,999 \ 9} = \frac{\varphi_{\text{AF}} - b}{a} \quad (\text{B.29})$$

From the resolution of Formulae (B.26) and (B.27), the estimated no-fire and all-fire values, with a confidence level of 95 %, are given in Formulae (B.30) and (B.31), respectively:

$$y_{\text{AF}} = \bar{y} - \frac{B_{\text{AF}}}{A} + \left( \frac{B_{\text{AF}}^2 - C_{\text{AF}} A}{A^2} \right)^{1/2} \quad (\text{B.30})$$

$$y_{\text{NF}} = \bar{y} - \frac{B_{\text{NF}}}{A} + \left( \frac{B_{\text{NF}}^2 - C_{\text{NF}} A}{A^2} \right)^{1/2} \quad (\text{B.31})$$

## B.6 Example 1: Calculation of relative frequencies

An example of experimentally tested quantity  $y$  (for example, fire current), with its respective number of fires  $i_k$  at a given level  $y_k$  (current level in milliamperes) is given in [Table B.1](#). The  $y_k$  values are ordered by increasing values.

**Table B.1 — Example of experimental results for the calculation of the frequencies**

$N = 20 \quad K = 7$							
$K$	1	2	3	4	5	6	7
$i_k$	0	0	10	14	16	19	29
$y_k$	540	560	580	600	620	640	660

From [Table B.1](#), we have:  $u = 3$  and  $o = 6$ .

Calculate the frequencies for  $3 \leq k \leq 6$  [Formula ((B.1))]:

$$p_3 = 0,5 \quad p_4 = 0,7 \quad p_5 = 0,8 \quad p_6 = 0,95$$

Using the Bayes estimator, calculate the other relative frequencies [Formulae (B.3), (B.4) and (B.5)]:

$$p_2 = 0,045 \quad p_1 = 0,019 \quad p_7 = 0,979 \quad 2$$

## B.7 Example 2: Calculation of a no-fire current and an all-fire current

Typical results for determining the no-fire and all-fire currents are reported in [Table B.2](#). The number of tests is equal to 20 for each level ( $N = 20$ ). The relative frequencies are calculated according to the procedure described above and example 1. For each frequency, the  $\varphi_k$  value is calculated using the inverse of the standard normal distribution,  $\Phi^{-1}$ .

The result of the calculation of the statistical parameters is collected in [Table B.3](#).

**Table B.2 — Example of values for calculation of the no-fire and all-fire currents**

$k$ (level)	$y_k$ (current level) mA	$l_k$ (number of occurrences)	$p_k$ (frequency of fires)	$\varphi_k$
1	230	0	0,040 58	-1,744 0
$2 = u$	235	3	0,150 00	-1,036 4
3	240	5	0,250 00	-0,674 5
4	245	6	0,300 00	-0,524 4
5	250	11	0,550 00	0,125 7
$6 = o$	255	16	0,800 00	0,841 6
7	260	20	0,956 32	1,709 5

**Table B.3 — Calculated statistical parameters**

Quantity	Equation	Result
$\bar{\varphi}$	(B.7)	-0,186 1
$\bar{y}$	(B.8)	245
$S_{yy}$	(B.9)	116,667
$S_{\varphi\varphi}$	(B.10)	1,375
$S_{\varphi y}$	(B.11)	12,430 8
$a$	(B.21)	0,106 55

**Table B.3** (continued)

Quantity	Equation	Result
$b$	(B.22)	-26,290 7
$D$	(B.12)	0,303 03
$F^{-1}(1-\alpha, 2, K-2)$	Inverse of $F$ -distribution function with: Probability: $1-\alpha=0,05$ Degree of freedom 1: 2 Degree of freedom 2: $K-2=5$	5,786 1
$\delta$	(B.14)	0,701 35
$A$	(B.15)	0,010 35
$B_{AF}$	(B.16) with $\varphi_{AF} = 3,719 1$	-0,416 1
$B_{NF}$	(B.17) with $\varphi_{NF} = 3,719 1$	0,376 4
$C_{AF}$	(B.18)	15,150 2
$C_{NF}$	(B.19)	12,382 0

The estimated no-fire and all-fire currents, with probability 0,000 1 and 0,999 9 respectively, are as follows [see Formulae (B.28) and (B.29)]:

$$y_{0,000\ 1} = 211,8 \text{ mA}$$

and

$$y_{0,999\ 9} = 281,7 \text{ mA}$$

Finally, calculate the no-fire and all-fire currents with a confidence level of 95 % using Formulae (B.30) and (B.31):

$$y_{NF} = I_{NF} = 197,4 \text{ mA}$$

$$y_{AF} = I_{AF} = 297,5 \text{ mA}$$

## Annex C (normative)

### Bruceton method

#### C.1 General

The Bruceton method is used to determine the level of stimulus at which there is a 50 % probability of obtaining a positive result.

#### C.2 Procedure

The method involves the application of different levels of stimulus and determining whether or not a positive reaction occurs. The performance of the trials is concentrated around the critical region. It takes place by decreasing the stimulus in one level at the next trial if a positive result is obtained and by increasing the stimulus in one level if a negative result is obtained. Usually about five preliminary trials are performed to find a starting level in approximately the right region and then at least 25 trials are performed to provide the data for the calculations.

#### C.3 Calculation of results

In determining the level at which the probability of obtaining a positive result is 50 % ( $H_{50}$ ), only the positive results (+) or only the negative results (-) are used, depending on which has the smaller amount. If the numbers are equal, either may be used. The data are recorded in a table (e.g. as in [Table C.1](#)) and summarized as shown in [Table C.2](#). Column 1 of [Table C.2](#) contains the drop heights, in ascending order, starting with the lowest level for which a test result is recorded. In column 2, 'i' is a number corresponding to the number of equal increments above the base or zero line. Column 3 contains the number of positive results [ $n(-)$ ] for each drop height. The fourth column tabulates the result of multiplying 'i' times 'n' and the fifth column tabulates the results of multiplying the square of 'i' times 'n'. A mean is calculated from Formula (C.1):

$$H_{50} = c + d \times \left( \frac{A}{N_S} \pm 0,5 \right) \quad (\text{C.1})$$

where

$$N_S = \sum n_i ;$$

$$A = \sum (i \times n_i) ;$$

$c$ , is the lowest drop height;

$d$ , is the height interval.

If negative results are used, the sign inside the brackets is positive; it is negative if positive results are used. The standard deviation,  $s$ , may be estimated using Formula ((C.2):

$$s = 1,62 \times d \times \frac{N_S \times B - A^2}{N_S^2} + 0,029 \quad (\text{C.2})$$

where

$$B = \sum (i^2 \times n_i)$$

EXAMPLE Using the following data from [Tables C.1](#) and [C.2](#): lowest drop height 10 cm; height level interval 5 cm; sum of  $i \cdot n(-)$  16; sum of  $i^2 \cdot n(-)$  30:

The mean height from Formula (C.1) is given as:

$$\begin{aligned} H_{50} &= 10 + 5 \left( \frac{16}{12} + 0,5 \right) \\ &= 19,2 \text{ cm} \end{aligned}$$

The standard deviation from Formula (C.2) is given as:

$$\begin{aligned} s &= \frac{12 \times 30 - 16^2}{12^2} + 0,029 \\ &= 6,1 \end{aligned}$$

**Table C.2 — Summarizing data**

Height cm	$i(-)$	Calculations using negatives $n(-)$	$i(-) \cdot n(-)$	$i^2(-) \cdot n(-)$
25	3	1	3	9
20	2	4	8	16
15	1	5	5	5
10	0	2	0	0
<b>Totals</b>		$N_S = 12$	$A = 16$	$B = 30$

Table C.1 — Recording data

Drop height cm	Trials																									Total + and -		
	1	2	3	4	5	6	7	8	9	10	11	12	13	14	15	16	17	18	19	20	21	22	23	24	25			
30							+																				1	—
25							-	+				+						+									4	1
20				+		-				+		-		+				-			+						5	4
15	+										-											-		+			3	5
10																									-		—	2
	Total + and -																									13	12	



## Bibliography

- [1] EN 13763-1, *Explosives for civil uses — Detonators and relays — Part 1: Requirements*





# British Standards Institution (BSI)

BSI is the national body responsible for preparing British Standards and other standards-related publications, information and services.

BSI is incorporated by Royal Charter. British Standards and other standardization products are published by BSI Standards Limited.

## About us

We bring together business, industry, government, consumers, innovators and others to shape their combined experience and expertise into standards-based solutions.

The knowledge embodied in our standards has been carefully assembled in a dependable format and refined through our open consultation process. Organizations of all sizes and across all sectors choose standards to help them achieve their goals.

## Information on standards

We can provide you with the knowledge that your organization needs to succeed. Find out more about British Standards by visiting our website at [bsigroup.com/standards](http://bsigroup.com/standards) or contacting our Customer Services team or Knowledge Centre.

## Buying standards

You can buy and download PDF versions of BSI publications, including British and adopted European and international standards, through our website at [bsigroup.com/shop](http://bsigroup.com/shop), where hard copies can also be purchased.

If you need international and foreign standards from other Standards Development Organizations, hard copies can be ordered from our Customer Services team.

## Subscriptions

Our range of subscription services are designed to make using standards easier for you. For further information on our subscription products go to [bsigroup.com/subscriptions](http://bsigroup.com/subscriptions).

With **British Standards Online (BSOL)** you'll have instant access to over 55,000 British and adopted European and international standards from your desktop. It's available 24/7 and is refreshed daily so you'll always be up to date.

You can keep in touch with standards developments and receive substantial discounts on the purchase price of standards, both in single copy and subscription format, by becoming a **BSI Subscribing Member**.

**PLUS** is an updating service exclusive to BSI Subscribing Members. You will automatically receive the latest hard copy of your standards when they're revised or replaced.

To find out more about becoming a BSI Subscribing Member and the benefits of membership, please visit [bsigroup.com/shop](http://bsigroup.com/shop).

With a **Multi-User Network Licence (MUNL)** you are able to host standards publications on your intranet. Licences can cover as few or as many users as you wish. With updates supplied as soon as they're available, you can be sure your documentation is current. For further information, email [bsmusales@bsigroup.com](mailto:bsmusales@bsigroup.com).

## BSI Group Headquarters

389 Chiswick High Road London W4 4AL UK

## Revisions

Our British Standards and other publications are updated by amendment or revision.

We continually improve the quality of our products and services to benefit your business. If you find an inaccuracy or ambiguity within a British Standard or other BSI publication please inform the Knowledge Centre.

## Copyright

All the data, software and documentation set out in all British Standards and other BSI publications are the property of and copyrighted by BSI, or some person or entity that owns copyright in the information used (such as the international standardization bodies) and has formally licensed such information to BSI for commercial publication and use. Except as permitted under the Copyright, Designs and Patents Act 1988 no extract may be reproduced, stored in a retrieval system or transmitted in any form or by any means – electronic, photocopying, recording or otherwise – without prior written permission from BSI. Details and advice can be obtained from the Copyright & Licensing Department.

## Useful Contacts:

### Customer Services

**Tel:** +44 845 086 9001

**Email (orders):** [orders@bsigroup.com](mailto:orders@bsigroup.com)

**Email (enquiries):** [cservices@bsigroup.com](mailto:cservices@bsigroup.com)

### Subscriptions

**Tel:** +44 845 086 9001

**Email:** [subscriptions@bsigroup.com](mailto:subscriptions@bsigroup.com)

### Knowledge Centre

**Tel:** +44 20 8996 7004

**Email:** [knowledgecentre@bsigroup.com](mailto:knowledgecentre@bsigroup.com)

### Copyright & Licensing

**Tel:** +44 20 8996 7070

**Email:** [copyright@bsigroup.com](mailto:copyright@bsigroup.com)



...making excellence a habit.™