

BS EN ISO 14122-2:2016



BSI Standards Publication

Safety of machinery — Permanent means of access to machinery

Part 2: Working platforms and walkways
(ISO 14122-2:2016)

National foreword

This British Standard is the UK implementation of EN ISO 14122-2:2016. It supersedes BS EN ISO 14122-2:2001+A1:2010 which is withdrawn.

The UK participation in its preparation was entrusted to Technical Committee B/208/1, Stairs and walkways - Industrial stairs.

A list of organizations represented on this committee can be obtained on request to its secretary.

This publication does not purport to include all the necessary provisions of a contract. Users are responsible for its correct application.

© The British Standards Institution 2016.
Published by BSI Standards Limited 2016

ISBN 978 0 580 84492 8

ICS 13.110

Compliance with a British Standard cannot confer immunity from legal obligations.

This British Standard was published under the authority of the Standards Policy and Strategy Committee on 30 June 2016.

Amendments/corrigenda issued since publication

Date	Text affected
------	---------------

EUROPEAN STANDARD

EN ISO 14122-2

NORME EUROPÉENNE

EUROPÄISCHE NORM

June 2016

ICS 13.110

Supersedes EN ISO 14122-2:2001

English Version

**Safety of machinery - Permanent means of access to
machinery - Part 2: Working platforms and walkways (ISO
14122-2:2016)**

Sécurité des machines - Moyens d'accès permanents
aux machines - Partie 2: Plates-formes de travail et
passerelles (ISO 14122-2:2016)

Sicherheit von Maschinen - Ortsfeste Zugänge zu
maschinellen Anlagen - Teil 2: Arbeitsbühnen und
Laufstege (ISO 14122-2:2016)

This European Standard was approved by CEN on 29 April 2016.

CEN members are bound to comply with the CEN/CENELEC Internal Regulations which stipulate the conditions for giving this European Standard the status of a national standard without any alteration. Up-to-date lists and bibliographical references concerning such national standards may be obtained on application to the CEN-CENELEC Management Centre or to any CEN member.

This European Standard exists in three official versions (English, French, German). A version in any other language made by translation under the responsibility of a CEN member into its own language and notified to the CEN-CENELEC Management Centre has the same status as the official versions.

CEN members are the national standards bodies of Austria, Belgium, Bulgaria, Croatia, Cyprus, Czech Republic, Denmark, Estonia, Finland, Former Yugoslav Republic of Macedonia, France, Germany, Greece, Hungary, Iceland, Ireland, Italy, Latvia, Lithuania, Luxembourg, Malta, Netherlands, Norway, Poland, Portugal, Romania, Slovakia, Slovenia, Spain, Sweden, Switzerland, Turkey and United Kingdom.



EUROPEAN COMMITTEE FOR STANDARDIZATION
COMITÉ EUROPÉEN DE NORMALISATION
EUROPÄISCHES KOMITEE FÜR NORMUNG

CEN-CENELEC Management Centre: Avenue Marnix 17, B-1000 Brussels

European foreword

This document (EN ISO 14122-2:2016) has been prepared by Technical Committee ISO/TC 199 “Safety of machinery” in collaboration with Technical Committee CEN/TC 114 “Safety of machinery” the secretariat of which is held by DIN.

This European Standard shall be given the status of a national standard, either by publication of an identical text or by endorsement, at the latest by December 2016, and conflicting national standards shall be withdrawn at the latest by December 2016.

Attention is drawn to the possibility that some of the elements of this document may be the subject of patent rights. CEN [and/or CENELEC] shall not be held responsible for identifying any or all such patent rights.

This document supersedes EN ISO 14122-2:2001.

This document has been prepared under a mandate given to CEN by the European Commission and the European Free Trade Association, and supports essential requirements of EU Directive(s).

For relationship with EU Directive(s), see informative Annex ZA, which is an integral part of this document.

According to the CEN-CENELEC Internal Regulations, the national standards organizations of the following countries are bound to implement this European Standard: Austria, Belgium, Bulgaria, Croatia, Cyprus, Czech Republic, Denmark, Estonia, Finland, Former Yugoslav Republic of Macedonia, France, Germany, Greece, Hungary, Iceland, Ireland, Italy, Latvia, Lithuania, Luxembourg, Malta, Netherlands, Norway, Poland, Portugal, Romania, Slovakia, Slovenia, Spain, Sweden, Switzerland, Turkey and the United Kingdom.

Endorsement notice

The text of ISO 14122-2:2016 has been approved by CEN as EN ISO 14122-2:2016 without any modification.

Annex ZA
(informative)

Relationship between this European Standard and the essential requirements of Directive 2006/42/EC machinery, and amending Directive 95/16/EC (recast) [2006 L157] aimed to be covered

This European Standard has been prepared under a Commission’s standardization request M/396 to provide one voluntary means of conforming to essential requirements of Directive 2006/42/EC of the European Parliament and of the Council of 17 May 2006 on machinery, and amending Directive 95/16/EC (recast) [2006 L157].

Once this standard is cited in the Official Journal of the European Union under that Directive, compliance with the normative clauses of this standard given in Table ZA.1 confers, within the limits of the scope of this standard, a presumption of conformity with the corresponding essential requirements of that Directive, and associated EFTA regulations.

Table ZA.1 — Correspondence between this European Standard and Directive 2006/42/EC [2006 L157]

Essential Requirements of Directive 2006/42/EC	Clause(s) / subclause(s) of this EN	Remarks / Notes
1.5.15 “Risks of slipping, tripping or falling”	All	
1.6.2 “Access to operating position and service points”	All	

WARNING 1 — Presumption of conformity stays valid only as long as a reference to this European Standard is maintained in the list published in the Official Journal of the European Union. Users of this standard should consult frequently the latest list published in the Official Journal of the European Union.

WARNING 2 — Other Union legislation may be applicable to the product(s) falling within the scope of this standard.

IMPORTANT: Compliance with the requirements of EN ISO 14122-1 and a relevant access-specific part of EN ISO 14122 is necessary to achieve presumption of conformity.

Contents

	Page
Foreword	iv
Introduction	v
1 Scope	1
2 Normative references	1
3 Terms and definitions	2
4 General requirements	3
4.1 General.....	3
4.1.1 Construction and materials.....	3
4.1.2 Safe access of operators.....	3
4.2 Specific requirements.....	3
4.2.1 Location.....	3
4.2.2 Dimensions.....	3
4.2.3 Facilities or equipment.....	6
4.2.4 Floorings.....	6
4.2.5 Design and construction for working platforms and walkways.....	8
4.2.6 Manoeuvrable platforms and walkways.....	9
5 Information for use for working platforms and walkways	9
Annex A (informative) Different methods of determining levels of slip-resistance	10
Annex B (informative) Significant technical changes between this part of ISO 14122 and the previous edition	11
Bibliography	13

Foreword

ISO (the International Organization for Standardization) is a worldwide federation of national standards bodies (ISO member bodies). The work of preparing International Standards is normally carried out through ISO technical committees. Each member body interested in a subject for which a technical committee has been established has the right to be represented on that committee. International organizations, governmental and non-governmental, in liaison with ISO, also take part in the work. ISO collaborates closely with the International Electrotechnical Commission (IEC) on all matters of electrotechnical standardization.

The procedures used to develop this document and those intended for its further maintenance are described in the ISO/IEC Directives, Part 1. In particular the different approval criteria needed for the different types of ISO documents should be noted. This document was drafted in accordance with the editorial rules of the ISO/IEC Directives, Part 2 (see www.iso.org/directives).

Attention is drawn to the possibility that some of the elements of this document may be the subject of patent rights. ISO shall not be held responsible for identifying any or all such patent rights. Details of any patent rights identified during the development of the document will be in the Introduction and/or on the ISO list of patent declarations received (see www.iso.org/patents).

Any trade name used in this document is information given for the convenience of users and does not constitute an endorsement.

For an explanation on the meaning of ISO specific terms and expressions related to conformity assessment, as well as information about ISO's adherence to the WTO principles in the Technical Barriers to Trade (TBT) see the following URL: [Foreword - Supplementary information](#)

The committee responsible for this document is ISO/TC 199, *Safety of machinery*.

This second edition cancels and replaces the first edition (ISO 14122-2:2001), which has been technically revised. It also incorporates the Amendment ISO 14122-2:2001/Amd 1:2010.

ISO 14122 consists of the following parts, under the general title *Safety of machinery — Permanent means of access to machinery*:

- *Part 1: Choice of fixed means and general requirements of access*
- *Part 2: Working platforms and walkways*
- *Part 3: Stairs, stepladders and guard-rails*
- *Part 4: Fixed ladders*

An additional part, dealing with mobile machinery, is under preparation.

Introduction

This International Standard is a type-B standard as stated in ISO 12100.

This International Standard is of relevance, in particular, for the following stakeholder groups representing the market players with regard to machinery safety:

- machine manufacturers (small, medium, and large enterprises);
- health and safety bodies (regulators, accident prevention organizations, market surveillance, etc.).

Others can be affected by the level of machinery safety achieved with the means of this International Standard by the above mentioned stakeholder groups:

- machine users/employers (small, medium, and large enterprises);
- machine users/employees (e.g. trade unions, organizations for peoples with special needs);
- service providers, e.g. for maintenance (small, medium, and large enterprises);
- consumers (in case of machinery intended for use by consumers).

The above mentioned stakeholder groups have been given the possibility to participate at the drafting process of this International Standard.

In addition, this International Standard is intended for standardization bodies elaborating type-C standards.

The requirements of this International Standard can be supplemented or modified by a type-C standard.

For machines which are covered by the scope of a type-C standard and which have been designed and built according to the requirements of that standard, the requirements of that type-C standard take precedence.

The purpose of this International Standard is to define the general requirements for safe access to machines. ISO 14122-1 gives guidance about the correct choice of access means when the necessary access to the machine is not possible directly from the ground level or from a floor or platform.

[Annex A](#) is informative.

The dimensions specified are consistent with established ergonomic data given in ISO 15534-3.

Safety of machinery — Permanent means of access to machinery —

Part 2: Working platforms and walkways

1 Scope

This part of ISO 14122 gives requirements for non-powered working platforms and walkways which are a part of a stationary machine, and to the non-powered adjustable parts (e.g. foldable, sliding) and movable parts of those fixed means of access.

NOTE 1 “Fixed” means of access are those mounted in such a manner (for example, by screws, nuts, welding) that they can only be removed by the use of tools.

This part of ISO 14122 specifies minimum requirements that also apply when the same means of access is required as the part of the building or civil construction (e.g. working platforms, walkways) where the machine is installed, on condition that the main function of that part of the construction is to provide a means of access to the machine.

NOTE 2 Where no local regulation or standards exist, this part of ISO 14122 can be used for means of access which are outside the scope of the standard.

It is intended that this part of ISO 14122 be used with ISO 14122-1 to give the requirements for walking platforms and walkways.

The ISO 14122 series as a whole is applicable to both stationary and mobile machinery where fixed means of access are necessary. It is not applicable to powered means of access such as lifts, escalators, or other devices specially designed to lift persons between two levels.

This part of ISO 14122 is not applicable to machinery manufactured before the date of its publication.

2 Normative references

The following documents, in whole or in part, are normatively referenced in this document and are indispensable for its application. For dated references, only the edition cited applies. For undated references, the latest edition of the referenced document (including any amendments) applies.

ISO 12100, *Safety of machinery — General principles for design — Risk assessment and risk reduction*

ISO 13857, *Safety of machinery — Safety distances to prevent hazard zones being reached by upper and lower limbs*

ISO 14120, *Safety of machinery — Guards — General requirements for the design and construction of fixed and movable guards*

ISO 14122-1:2016, *Safety of machinery — Permanent means of access to machinery — Part 1: Choice of fixed means and general requirements of access*

ISO 14122-3:2016, *Safety of machinery — Permanent means of access to machinery — Part 3: Stairs, stepladders and guard-rails*

ISO 15534-1:2000, *Ergonomic design for the safety of machinery — Part 1: Principles for determining the dimensions required for openings for whole-body access into machinery*

ISO 15534-3:2000, *Ergonomic design for the safety of machinery — Part 3: Anthropometric data*

3 Terms and definitions

For the purposes of this document, the terms and definitions given in ISO 12100, ISO 14122-1, and the following apply.

3.1 flooring
assembly of elements making up the floor of a *walkway* (3.2) or a *working platform* (3.3) and being in direct contact with footwear

3.2 walkway
level or inclined surface used for moving from one point to another

3.2.1 maneuverable walkway
level or inclined surface used for moving, installed at the machine permanently, and intended to be shortened, elongated, or altered in its position

Note 1 to entry: This includes foldable, slidable, adjustable and/or hinged to, or slid from an adjacent platform or walkway.

3.3 working platform
horizontal level surface used for the operation, maintenance, inspection, repair, sampling, and other phases of work in connection with the machinery

3.3.1 maneuverable platform
level surface used for operation, installed at the machine permanently, and intended to be shortened, elongated, or altered in its position

Note 1 to entry: This includes foldable, slidable, adjustable and/or hinged to, or slid from an adjacent platform or *walkway* (3.2).

3.4 slip resistant surface
flooring surface designed for improving the grip of footwear

3.5 baseboard
filler plate between *working platform* (3.3) and adjacent construction element

3.6 toe-plate
rigid vertical plate on a landing platform or *flooring* (3.1) to prevent the fall of objects from a floor level

Note 1 to entry: See [Figure 2](#) and ISO 14122-3:2016, Figure 2.

3.7 access gauge
space to be cleared of any structures, obstacles, and obstruction in order to enable access

3.8 head-height
minimum vertical distance, cleared of all obstacles (such as beams, ducts, etc.) above the pitch line

Note 1 to entry: h in [Figure 1](#).

4 General requirements

4.1 General

4.1.1 Construction and materials

Working platforms and walkways shall be designed and constructed and the materials selected so that they withstand the foreseeable conditions of use. In particular, at least the following details shall be taken into account:

- a) Walkways and working platforms shall be designed and constructed to prevent the hazards due to falling objects. For guard-rails and toe-plates, see ISO 14122-3:2016, Clause 7, and for openings in the flooring, see [4.2.4.5](#).
- b) The removal of any part of the machine shall, as far as practicable, be possible without removing guard-rails, pieces of flooring, or other permanent protective barriers.

4.1.2 Safe access of operators

Walkways and working platforms shall be designed and constructed so that they are safe to use. In particular, the following aspects shall be taken into account:

- a) Walkways and working platforms shall be designed and built in such a way that the walking surfaces have durable slip resistant properties.
- b) The parts of machinery which operators have to walk or stand on shall be designed and fitted to prevent persons falling from them (see ISO 14122-3).
- c) Working platforms and access to working platforms shall be designed in such a way that operators can quickly leave their workplace in the event of a hazard or can be quickly helped and easily evacuated when necessary.
- d) Handrails and other supports shall be designed, built, and laid out in such a way that they are used instinctively.

4.2 Specific requirements

4.2.1 Location

Where possible, walkways and working platforms shall be located or protected to prevent exposure to harmful materials or substances. The walkways and walking platforms shall also be located away from the accumulation of material, such as earth, which is likely to cause slipping.

Where there are, for example, moving objects, non-protected surfaces with extreme temperatures, unprotected live electrical equipment, measures such as guards in accordance with ISO 14120 or safety distances in accordance with ISO 13857 shall be applied either to the machinery or fixed access.

Where possible, working platforms shall be designed and located to enable persons to work in an ergonomic position between 500 mm and 1 700 mm above the surface of the working platform without increasing the risk of falling.

4.2.2 Dimensions

The clear length and width of walkways and working platforms intended for operation and maintenance shall be determined by the following:

- a) the demands of the task, e.g. positions, nature and speed of movement, application of force, etc.;
- b) whether or not tools, spare parts, etc. are being carried;

- c) frequency and duration of task and use;
- d) number of operators and used equipment on walkways or working platforms at the same time;
- e) possibility of operators meeting;
- f) whether or not additional equipment, protective clothing is being worn or personal protective equipment is being carried;
- g) the presence of obstacles;
- h) walkway ending in a dead end;
- i) walls likely to damage or mark operators' clothing;
- j) the need for unrestricted work-movements and the need for space when using foreseeable tools.

In accordance with the values given in ISO 15534-1 and ISO 15534-3, unless exceptional circumstances exist, the minimum head-height, h , over working platforms and walkways shall be 2 100 mm (see [Figure 1](#)). Where space is restricted, [Figure 1](#) provides dimensions to ensure adequate clearance is given in the area around the head.

If an obstacle (e.g. pipe) is crossing the walkway at the head-height, the minimum head-height, h , may be reduced to no less than 1 900 mm. Measures such as padding and warning signs shall be provided.

The clear width, w , of a walkway shall be ≥ 800 mm (see [Figure 1](#)).

When the walkway is usually subject to passage or crossing of several persons simultaneously, the clear width, w , shall be increased to at least 1 000 mm.

Due to the design of the machine, the environment, or the occasional use, e.g. less than 30 days per year and less than two hours per day, the clear width, w , may be reduced from 800 mm to 600 mm (see [Figure 1](#)).

As an exception, for a short distance less than 2 000 mm, the clear width, w , may be reduced from 600 mm to 500 mm (see [Figure 1](#)).

If the available space at the floor level is restricted due to pipework, electric, or constructive reason of machinery, the walkway width at floor level can be reduced to 500 mm at the minimum and to a maximum height of 200 mm (see [Figure 1](#)).

Any obstruction, such as pipes or cable trays fitted along the walkway at either head-height, h , or finished floor level, shall reduce the available width to not less than 500 mm (see [Figure 1](#)).

The width of the walkway, when designated as an escape way, should meet the requirements of appropriate regulations.

If the horizontal walkway is interrupted and the vertical height between the two levels cannot be closed by a stair or ramp, a single step is allowed under the following conditions.

- The single step shall be clearly visible (e.g. by colour, cranked guard-rail).
- The height shall be between 150 mm and 300 mm.

4.2.3 Facilities or equipment

Guard-rails in accordance with ISO 14122-3 shall be provided if there is a risk of falling from walkways or working platforms from a height of 500 mm or more.

Guard-rails are also required at places where there is a risk of sinking or an adjacent structure collapsing, e. g. access near a hopper filled with granular material, access to an extraction machine on a roof made of glass or of some other material not able to withstand the weight of a person. Appropriate facilities shall be provided for handling heavy objects without rolling or placing them on working platforms, where necessary.

4.2.4 Floorings

4.2.4.1 Restrictions due to structures

When pipes or other structures pass through a working platform or walkway, openings may be allowed if there is no alternative route. In such cases, the width shall be designed according to [4.2.2](#) and [4.2.4.5.2](#).

4.2.4.2 Hazards due to stagnation and/or accumulation of liquid

Floorings shall be designed such that any liquids spilled on them are drained away. If this requirement is not possible to fulfil, e.g. for hygienic reasons, slipping and other hazards caused by the liquid shall be prevented.

4.2.4.3 Hazards due to accumulation of substances

Floorings shall be designed in such a way that neither dirt, snow, ice, etc., nor may other substances accumulate. Therefore, permeable floorings, such as gratings or cold formed planks are recommended.

If this is not possible, and permeable floorings are not used, facilities for removing the accumulated substances shall be provided.

4.2.4.4 Trip hazards

To avoid trip hazards, the greatest difference between the tops of neighbouring flooring surfaces shall not exceed 4 mm in height, and the gap between two adjacent floorings shall be less than 20 mm.

4.2.4.5 Hazards generated by falling objects

4.2.4.5.1 Open flooring

Generally, the risk assessment affects the design of open floorings for working platforms or walkways. The following requirements apply.

- Floorings of working platforms or walkway shall only have such maximum openings that a ball with a diameter of 35 mm cannot fall through.
- Floorings above a place where people are working, as opposed to occasional passage, shall have such maximum openings that a ball with a diameter of 20 mm cannot fall through. Unless the same safety is guaranteed by other suitable means, the maximum lengths of the opening shall be 100 mm.
- The increase of openings (see [4.2.4.2](#)) should only be made where the spill of production material does apply or cannot be prevented by other means.

In cases where the risk assessment concludes that hazards caused by objects or other materials falling or passing through the flooring are more significant than the slipping, falling, and other hazards, the flooring shall have no opening.

4.2.4.5.2 Gap between working platform, walkways and adjacent construction element

Where gaps exist in the flooring, e.g. for the passage of piping or other elements, or between the edge of a working platform or walkway and adjacent structures, the following requirements apply.

- If gaps are >20 mm, either a toe-plate (3.6) with a height of at least 100 mm shall be fitted or the gap shall be reduced to ≤20 mm by means of a baseboard (3.5). See Figure 2.
- If gaps are >20 mm and ≤120 mm, a toe-plate with a height of at least 100 mm shall be fitted. If, because of an obstruction (see Figure 2), there is insufficient space for a full height toe-plate, the height of the toe-plate can be locally reduced to a minimum of 50 mm (see Figure 2).
- If the gap is >120 mm, the following requirements apply.
 - a) If gaps are >120 mm and ≤180 mm, a toe-plate and a handrail (see ISO 14122-3) or an equivalent structure with a height of 900 mm to 1 100 mm shall be provided.
 - b) If gaps are >180 mm, whole-body access is possible (see ISO 13857) and the working platform or walkway shall be fitted with a guard-rail according to ISO 14122-3:2016, Clause 7, to prevent access to the gap.

Dimensions in millimetres

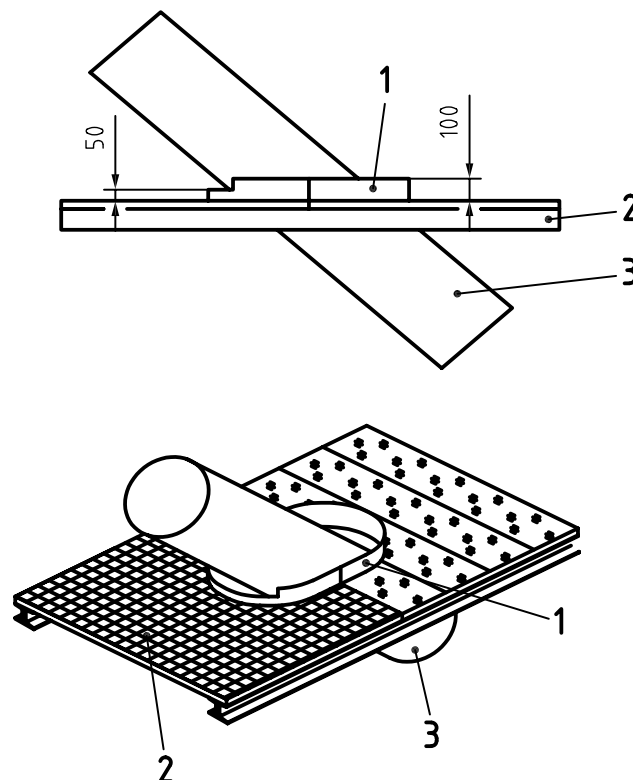

Key

- 1 toe-plate
- 2 detail enlargement of platform/walkway
- 3 pipe

Figure 2 — Example of a toe-plate

4.2.4.6 Falling through flooring hazard

If flooring is made of detachable elements, i.e. removable, for example, where required for maintenance of auxiliary equipment mounted below flooring:

- any hazardous movement of these elements shall be prevented, e.g. by fasteners;
- it shall be possible to inspect fixings in order to detect any corrosion or any hazardous loosening or change of position of clamps.

NOTE For information on trap doors, see ISO 14122-4.

4.2.4.7 Slip hazards

Floorings shall have a surface finish which is designed and manufactured to reduce the risk of slipping.

Where enhanced slip resistance is required and ribbed walkways as a protective measure are used against slip hazards on ramps with an angle of pitch, α , of between 10° and 20° , the distance between the ribs, T , should be between 400 mm and 500 mm. The range of the height, h , of the ribs should be between 10 mm and 20 mm.

The range of the width, b , of the ribs should be between 10 mm and 20 mm.

See [Figure 3](#).

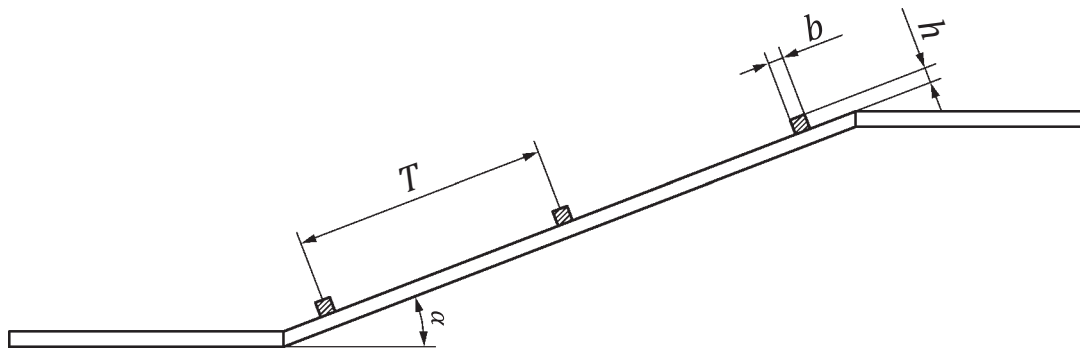

Key

- T distance of two ribs
- b width
- h height
- α angle of pitch

NOTE For information on enhanced slip resistance, see [Annex A](#).

Figure 3 — ramp with ribs

4.2.5 Design and construction for working platforms and walkways

The schedule of specifications for the working platforms and walkways shall state the load for which it is designed.

To determine the design load, at least the following shall be taken into account:

- the number of persons at work on the specific location;
- the mass of the tools, spare parts, and work equipment needed on location;
- the strength of impact on the structure due to a drop of tools and/or machine (replacement) parts;

- the possible concentrated loads due to the weight distribution (geometrics) of the used parts needed at the work;
- the weight due to environmental causes (e.g. fluids, water, snow, ice, spill, etc.) that can be deposited at the location of work on the platform.

The minimum loads to take into account for walkways and working platforms are as follows:

- 2 kN/m² uniformly distributed load to account for the structure;
- 1,5 kN concentrated load applied in the most unfavourable position over an area of 200 mm × 200 mm of the floor.

When loaded with the design load, the deflection of the flooring shall not exceed 1/200th of the span.

When designing a walkway, the deflection under the dynamic loading shall also be taken into account. Possible lateral movements of a platform in normal use shall not lead to loss of balance of the user of the platform or walkway.

The difference between the loaded and a neighbouring unloaded flooring shall not exceed 4 mm in height.

The safe strength and stiffness of design of the walkways and working platforms shall be verified either by calculation or by tests.

4.2.6 Manoeuvrable platforms and walkways

Where fixed access is not practicable, foldable, slidable, height-adjustable, or hinged parts may be fitted.

In addition to the requirements for fixed platforms and walkways, the following requirements apply:

- it is secured to the fixed means of access
- it shall be locked in the intended positions when in use and in the stored position, e.g. by gravity, spring force or self-locking mechanism;
- it shall be designed to minimize risk of crushing, in particular when opening or closing;
- the manual operating force needed to adjust the height shall not exceed recommended force limits for machinery operation (see EN 1005-3:2002+A1:2008 and EN 1005-2:2003+A1:2008);
- in the position to be used, it shall not
 - block any passage way, or
 - create a confined space(s).

NOTE A section of a fixed access system can be adjustable for convenient storage on the machine.

5 Information for use for working platforms and walkways

In addition to the general requirements (see ISO 14122-1:2016, Clause 7) for manoeuvrable platforms and walkways, the manufacturer shall state in the instructions how foldable, sliding, height-adjustable or hinged parts are to be locked in the intended positions when in use and in the stored position.

Annex A (informative)

Different methods of determining levels of slip-resistance

No international standards existed at the time of publication of this part of ISO 14122, but the following national documents are some of those available. See the Bibliography.

France

References [\[13\]](#), [\[14\]](#), [\[15\]](#) and [\[16\]](#).

Germany

Reference [\[12\]](#).

United Kingdom

References [\[9\]](#), [\[10\]](#) and [\[11\]](#).

Annex B (informative)

Significant technical changes between this part of ISO 14122 and the previous edition

See [Table B.1](#).

Table B.1 — Technical changes

ISO 14122-2	ISO 14122-2:2001 ISO 14122-2:2001/Amd1:2010
Modified: This part is limited only to “stationary machinery”, is applicable on “non-powered adjustable parts”	1 Scope
Updated	2 Normative references
New: “ 3.2.1 , maneuverable walkway” “ 3.3.1 , maneuverable platform” “ 3.5 , baseboard” “ 3.6 , toe-plate” “ 3.7 , access gauge” “ 3.8 , head-height” Updated: 3.3	3 Terms and definitions
Hanging paragraph deleted	4.1
Moved to ISO 14122-1, Clause 6	4.1.1, a) to e)
Moved to ISO 14122-1, Clause 6	4.1.2, a)
Reference on guards (ISO 14120)	4.2.1, 2nd paragraph
Deleted: “h)” Replaced: Note 1 and 2 by requirements for the “clear width, w,” and the “head-height, h” Defined: requirement on clear width, w, and on height of any obstruction at the floor level Added: requirement on interrupted walkways, if the vertical gap between the two levels cannot be closed by a ramp or stair Added: Note for “escape ways” Added: Figure 1 , “Access gauge on walkways”	4.2.2
Added: 4.2.4.1 “Restriction due to structures”	—
4.2.4.2	4.2.4.1
4.2.4.3	4.2.4.2
4.2.4.4 and new requirement on gaps	4.2.4.3
NOTE This list includes the significant technical changes but is not an exhaustive list of all modifications from the previous version.	

Table B.1 (continued)

ISO 14122-2	ISO 14122-2:2001 ISO 14122-2:2001/Amd1:2010
4.2.4.5	4.2.4.4
4.2.4.5.1 "Open flooring"	—
Modified and added: requirement on maximum lengths	4.2.4.4, a)
4.2.4.5.2 "Gap between working platform, walkways, and adjacent construction elements", new requirements, and Figure 2 , "Example of a toe-plate"	4.2.4.4, b)
4.2.4.6	4.2.4.5
4.2.4.7 , considering ribbed walkways	4.2.4.6
4.2.5 , added: criteria to be taken into account to determine the design load and considering the deflection under the dynamic use	4.2.5
New: 4.2.6 , "Maneuverable platforms and walkways"	—
Modified: "Information for use for working platforms and walkways"	Clause 5, "Assembly instructions"
NOTE This list includes the significant technical changes but is not an exhaustive list of all modifications from the previous version.	

Bibliography

- [1] ISO 13854, *Safety of machinery — Minimum gaps to avoid crushing of parts of the human body*
- [2] ISO 14122-4, *Safety of machinery — Permanent means of access to machinery — Part 4: Fixed ladders*
- [3] ISO 15534-2:2000, *Ergonomic design for the safety of machinery — Part 2: Principles for determining the dimensions required for access openings*
- [4] EN 353-1, *Personal protective equipment against falls from a height — Part 1: Guided type fall arresters including a rigid anchor line*
- [5] EN 364, *Personal protective equipment against falls from a height; test methods*
- [6] EN 795, *Personal fall protection equipment — Anchor devices*
- [7] EN 1005-2:2003+A1:2008, *Safety of machinery — Human physical performance — Part 2: Manual handling of machinery and component parts of machinery*
- [8] EN 1005-3:2002+A1:2008, *Safety of machinery — Human physical performance — Part 3: Recommended force limits for machinery operation*
- [9] BS 4592-0:2006+A1:2012, *Flooring, stair treads and handrails for industrial use. Common design requirements and recommendations for installation*
- [10] BS 7188:1998+A2:2009, *Impact absorbing playground surfacing. Performance requirements and test methods*
- [11] BS 8204-3:2004+A2:2011, *Screeds, bases and in situ floorings. Polymer modified cementitious levelling screeds and wearing screeds. Code of practice*
- [12] BGR 181 — (Oktober 2003) — BG-Regel — Fußböden in Arbeitsräumen und Arbeitsbereichen mit Rutschgefahr
- [13] Exigences pour une norme de mesure de la glissance des sols — Etude documentaire et discussion — ND 1987 — 159 — 95 — INRS
- [14] Sols anti-dérapants — Critère d'évaluation de la résistance au glissement — Application aux sols des industries de l'alimentation — ND 1853 — 145 — 91
- [15] Normalisation de la glissance des sols et des chaussures — ND 1936 — 152 — 93
- [16] Glissance des sols et coefficients de frottement — Cahier 2484 (avril 1991) — CSTB

British Standards Institution (BSI)

BSI is the national body responsible for preparing British Standards and other standards-related publications, information and services.

BSI is incorporated by Royal Charter. British Standards and other standardization products are published by BSI Standards Limited.

About us

We bring together business, industry, government, consumers, innovators and others to shape their combined experience and expertise into standards-based solutions.

The knowledge embodied in our standards has been carefully assembled in a dependable format and refined through our open consultation process. Organizations of all sizes and across all sectors choose standards to help them achieve their goals.

Information on standards

We can provide you with the knowledge that your organization needs to succeed. Find out more about British Standards by visiting our website at bsigroup.com/standards or contacting our Customer Services team or Knowledge Centre.

Buying standards

You can buy and download PDF versions of BSI publications, including British and adopted European and international standards, through our website at bsigroup.com/shop, where hard copies can also be purchased.

If you need international and foreign standards from other Standards Development Organizations, hard copies can be ordered from our Customer Services team.

Copyright in BSI publications

All the content in BSI publications, including British Standards, is the property of and copyrighted by BSI or some person or entity that owns copyright in the information used (such as the international standardization bodies) and has formally licensed such information to BSI for commercial publication and use.

Save for the provisions below, you may not transfer, share or disseminate any portion of the standard to any other person. You may not adapt, distribute, commercially exploit, or publicly display the standard or any portion thereof in any manner whatsoever without BSI's prior written consent.

Storing and using standards

Standards purchased in soft copy format:

- A British Standard purchased in soft copy format is licensed to a sole named user for personal or internal company use only.
- The standard may be stored on more than 1 device provided that it is accessible by the sole named user only and that only 1 copy is accessed at any one time.
- A single paper copy may be printed for personal or internal company use only.

Standards purchased in hard copy format:

- A British Standard purchased in hard copy format is for personal or internal company use only.
- It may not be further reproduced – in any format – to create an additional copy. This includes scanning of the document.

If you need more than 1 copy of the document, or if you wish to share the document on an internal network, you can save money by choosing a subscription product (see 'Subscriptions').

Reproducing extracts

For permission to reproduce content from BSI publications contact the BSI Copyright & Licensing team.

Subscriptions

Our range of subscription services are designed to make using standards easier for you. For further information on our subscription products go to bsigroup.com/subscriptions.

With **British Standards Online (BSOL)** you'll have instant access to over 55,000 British and adopted European and international standards from your desktop. It's available 24/7 and is refreshed daily so you'll always be up to date.

You can keep in touch with standards developments and receive substantial discounts on the purchase price of standards, both in single copy and subscription format, by becoming a **BSI Subscribing Member**.

PLUS is an updating service exclusive to BSI Subscribing Members. You will automatically receive the latest hard copy of your standards when they're revised or replaced.

To find out more about becoming a BSI Subscribing Member and the benefits of membership, please visit bsigroup.com/shop.

With a **Multi-User Network Licence (MUNL)** you are able to host standards publications on your intranet. Licences can cover as few or as many users as you wish. With updates supplied as soon as they're available, you can be sure your documentation is current. For further information, email subscriptions@bsigroup.com.

Revisions

Our British Standards and other publications are updated by amendment or revision.

We continually improve the quality of our products and services to benefit your business. If you find an inaccuracy or ambiguity within a British Standard or other BSI publication please inform the Knowledge Centre.

Useful Contacts

Customer Services

Tel: +44 345 086 9001

Email (orders): orders@bsigroup.com

Email (enquiries): cservices@bsigroup.com

Subscriptions

Tel: +44 345 086 9001

Email: subscriptions@bsigroup.com

Knowledge Centre

Tel: +44 20 8996 7004

Email: knowledgecentre@bsigroup.com

Copyright & Licensing

Tel: +44 20 8996 7070

Email: copyright@bsigroup.com

BSI Group Headquarters

389 Chiswick High Road London W4 4AL UK