

BS EN ISO 14088:2012



BSI Standards Publication

**Leather — Chemical tests
— Quantitative analysis
of tanning agents by filter
method (ISO 14088:2012)**

bsi.

...making excellence a habit.™

National foreword

This British Standard is the UK implementation of EN ISO 14088:2012.

The UK participation in its preparation was entrusted to Technical Committee TCI/69, Footwear, leather and coated fabrics.

A list of organizations represented on this committee can be obtained on request to its secretary.

This publication does not purport to include all the necessary provisions of a contract. Users are responsible for its correct application.

© The British Standards Institution 2012. Published by BSI Standards Limited 2012

ISBN 978 0 580 68763 1

ICS 59.140.30

Compliance with a British Standard cannot confer immunity from legal obligations.

This British Standard was published under the authority of the Standards Policy and Strategy Committee on 29 February 2012.

Amendments issued since publication

Date	Text affected
------	---------------

ICS 59.140.30

English Version

Leather - Chemical tests - Quantitative analysis of tanning agents by filter method (ISO 14088:2012)

Cuir - Essais chimiques - Analyse quantitative des agents de tannage par la méthode au filtre cloche (ISO 14088:2012)

Leder - Chemische Prüfung - Quantitative Analyse von Gerbstoffen durch Filterverfahren (ISO 14088:2012)

This European Standard was approved by CEN on 31 January 2012.

CEN members are bound to comply with the CEN/CENELEC Internal Regulations which stipulate the conditions for giving this European Standard the status of a national standard without any alteration. Up-to-date lists and bibliographical references concerning such national standards may be obtained on application to the CEN-CENELEC Management Centre or to any CEN member.

This European Standard exists in three official versions (English, French, German). A version in any other language made by translation under the responsibility of a CEN member into its own language and notified to the CEN-CENELEC Management Centre has the same status as the official versions.

CEN members are the national standards bodies of Austria, Belgium, Bulgaria, Croatia, Cyprus, Czech Republic, Denmark, Estonia, Finland, France, Germany, Greece, Hungary, Iceland, Ireland, Italy, Latvia, Lithuania, Luxembourg, Malta, Netherlands, Norway, Poland, Portugal, Romania, Slovakia, Slovenia, Spain, Sweden, Switzerland, Turkey and United Kingdom.



EUROPEAN COMMITTEE FOR STANDARDIZATION
COMITÉ EUROPÉEN DE NORMALISATION
EUROPÄISCHES KOMITEE FÜR NORMUNG

Management Centre: Avenue Marnix 17, B-1000 Brussels

Foreword

This document (EN ISO 14088:2012) has been prepared by Technical Committee CEN/TC 289 "Leather", the secretariat of which is held by UNI, in collaboration with Technical Committee IULTCS "International Union of Leather Technologists and Chemists Societies".

This European Standard shall be given the status of a national standard, either by publication of an identical text or by endorsement, at the latest by August 2012, and conflicting national standards shall be withdrawn at the latest by August 2012.

Attention is drawn to the possibility that some of the elements of this document may be the subject of patent rights. CEN [and/or CENELEC] shall not be held responsible for identifying any or all such patent rights.

According to the CEN/CENELEC Internal Regulations, the national standards organizations of the following countries are bound to implement this European Standard: Austria, Belgium, Bulgaria, Croatia, Cyprus, Czech Republic, Denmark, Estonia, Finland, France, Germany, Greece, Hungary, Iceland, Ireland, Italy, Latvia, Lithuania, Luxembourg, Malta, Netherlands, Norway, Poland, Portugal, Romania, Slovakia, Slovenia, Spain, Sweden, Switzerland, Turkey and the United Kingdom.

Contents

Page

Foreword	iv
1 Scope	1
2 Normative references	1
3 Principle	1
4 Reagents	1
5 Apparatus	1
6 Sampling and sample preparation.....	3
7 Instrumental analysis	4
7.1 Preparation of the analytical solution	4
7.1.1 Vegetable tanning agents in powder/solid form	4
7.1.2 Vegetable tanning agents in liquid form	4
7.1.3 Synthetic tanning agents in powder form.....	4
7.1.4 Synthetic tanning agents in liquid form.....	4
7.1.5 Vegetable tanning agents organic solvent extracted in powder form.....	4
7.2 Preparation of the bell.....	5
7.3 De-tanning the analytical solution (determination of the non-tanning agents)	5
7.4 Determination of soluble substances	5
7.5 Determination of total solids	6
8 Calculation and expression of the results	6
9 Test report.....	7
Annex A (informative) Approximate quantity of vegetable tannic extract agent in powder/solid form to be weighed.....	8
Annex B (normative) Determination of hide powder blank value	9
Annex C (informative) Suppliers of hide powder.....	10

Foreword

ISO (the International Organization for Standardization) is a worldwide federation of national standards bodies (ISO member bodies). The work of preparing International Standards is normally carried out through ISO technical committees. Each member body interested in a subject for which a technical committee has been established has the right to be represented on that committee. International organizations, governmental and non-governmental, in liaison with ISO, also take part in the work. ISO collaborates closely with the International Electrotechnical Commission (IEC) on all matters of electrotechnical standardization.

International Standards are drafted in accordance with the rules given in the ISO/IEC Directives, Part 2.

The main task of technical committees is to prepare International Standards. Draft International Standards adopted by the technical committees are circulated to the member bodies for voting. Publication as an International Standard requires approval by at least 75 % of the member bodies casting a vote.

Attention is drawn to the possibility that some of the elements of this document may be the subject of patent rights. ISO shall not be held responsible for identifying any or all such patent rights.

ISO 14088 was prepared by the Chemical Test Commission of the International Union of Leather Technologists and Chemists Societies (IUC Commission, IULTCS) in collaboration with the European Committee for Standardization (CEN) Technical Committee CEN/TC 289, *Leather*, the secretariat of which is held by UNI, in accordance with the Agreement on technical cooperation between ISO and CEN (Vienna Agreement).

IULTCS, originally formed in 1897, is a world-wide organization of professional leather societies to further the advancement of leather science and technology. IULTCS has three Commissions, which are responsible for establishing international methods for the sampling and testing of leather. ISO recognizes IULTCS as an international standardizing body for the preparation of test methods for leather.

Leather — Chemical tests — Quantitative analysis of tanning agents by filter method

1 Scope

This International Standard specifies a test method for the determination of tanning agents through filtration of all vegetable and synthetic tanning products.

2 Normative references

The following referenced documents are indispensable for the application of this document. For dated references, only the edition cited applies. For undated references, the latest edition of the referenced document (including any amendments) applies.

ISO 3696, *Water for analytical laboratory use — Specification and test methods*

3 Principle

Indirect gravimetric analysis of vegetable and synthetic tanning agents through fixing of the absorbent compounds on low-chromed hide powder.

4 Reagents

4.1 Distilled water, freshly prepared according to ISO 3696 (Water for analytical laboratory use, Grade 3).

The pH value of the water shall be between 5 and 6. When using methyl red, the water should not turn red. The evaporation residue of 100 ml should be less than 1 mg.

4.2 Hide powder¹⁾, containing not more than 0,5 % chromium oxide and with a humidity not more than 13 %.

The blank value of the hide powder shall be calculated according to Annex B.

4.3 Gelatine solution, of 1 g gelatine and 10 g sodium chloride, filled up to 100 ml with distilled water, adjusted to pH = 4,7.

5 Apparatus

The glass equipment shall be resistant to the action of distilled water. The flasks and tubes shall be Class A.

Use normal laboratory equipment and, in particular, the following.

5.1 Desiccator, with an airtight cover and containing silica orange gel.

1) See Annex C.

5.2 Evaporation dishes, suitable for slowly evaporating water.

These shall be short with flat bases and measure 7 cm to 8,5 cm in diameter.

Use silver dishes. If this is not possible, preferably use dishes made of stainless steel or, if necessary, ceramic or glass.

5.3 Water bath.

5.4 Drying oven, whose temperature shall be kept at the operating range of $(102 \pm 2) ^\circ\text{C}$.

5.5 Analytical balance, with a precision of 0,2 mg at a load of 200 g.

5.6 Technical balance, with a precision of 0,1 g at a load of 1 000 g.

5.7 Procter bell (see Figure 1), composed of a cylindrical glass bell (length of the cylindrical part: $90 \text{ mm} \pm 1 \text{ mm}$; internal diameter of the cylindrical part: $28 \text{ mm} \pm 1 \text{ mm}$). A perforated rubber cork is inserted into the narrow part of the bell. A capillary glass tube (internal diameter 1,5 mm) with two right-angled bends is inserted into the hole in the cork as shown in Figure 1. The end of the shortest part can fit right down to the base of the cork.

Dimensions in millimetres

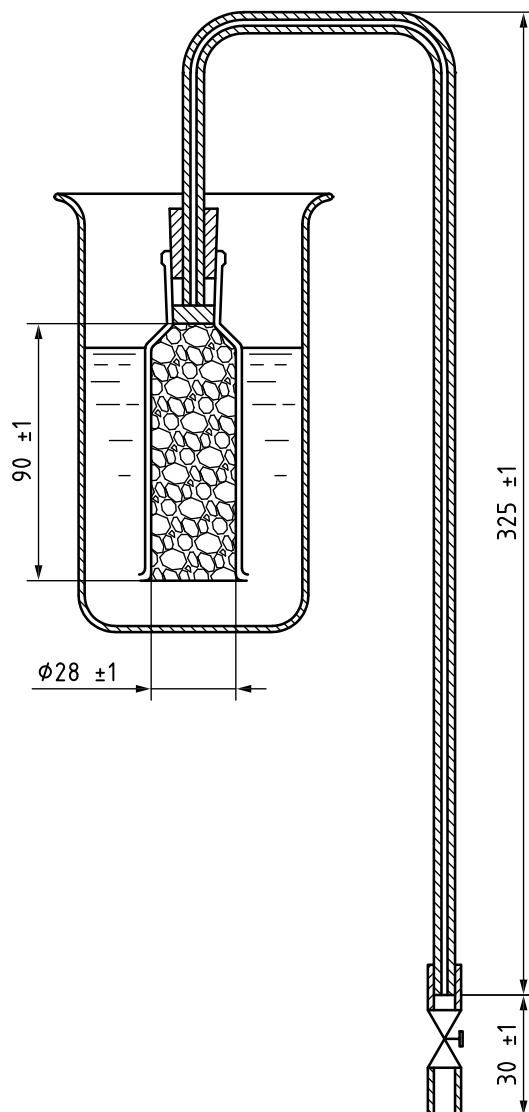

Figure 1 — Procter bell

- 5.8 **Polyethylene tube**, the tube shall be the right size to fit onto the bell's capillary glass tube.
- 5.9 **Hoffman clamp**.
- 5.10 **1 000 ml volumetric flasks**.
- 5.11 **50 ml pipette**.
- 5.12 **Vacuum filter system** (e.g. Figure 2).

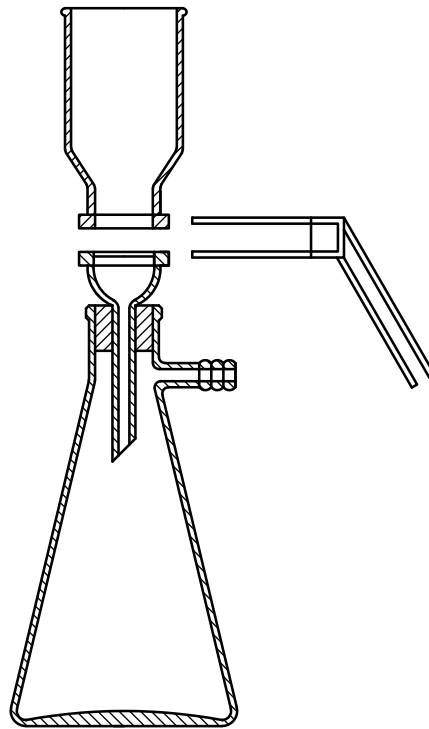

Figure 2 — Vacuum filter system

- 5.13 **Cellulose acetate membrane filters**, with pores of 0,45 μm and 3 μm .
- 5.14 **50 ml and 100 ml measuring cylinders**.

6 Sampling and sample preparation

There should be a generous, representative sample of the tanning agents for analysis; this should be thoroughly mixed.

If the particles are heterogeneous, resort to manual or mechanical milling to homogenize the size of the particles. The particle size should not be smaller than 300 μm to avoid blocking the Procter bell.

7 Instrumental analysis

7.1 Preparation of the analytical solution

7.1.1 Vegetable tanning agents in powder/solid form

Weigh the appropriate quantity (see Table A.1) of vegetable tanning agents on an analytical balance (5.5). Add this to 800 ml of hot (60 °C to 80 °C) distilled water in a 1 000 ml volumetric flask (5.10). Shake the flask to fully dissolve the tanning agents. There may be some residue if there is any insoluble matter in the sample. Leave it to cool down in a water bath at (20 ± 2) °C and add distilled water (4.1) up to the mark.

The aim is to obtain an analytical solution containing between 3,75 g and 4,25 g of substances absorbed by the hide powder. If the tanning content in the solution goes beyond these limits, repeat the analysis with a sample of suitable quantity.

7.1.2 Vegetable tanning agents in liquid form

Weigh the tanning agents on an analytical balance (5.5), taking into account the percentage of content in dry form. Add this to in a 1 000 ml volumetric flask (5.10) containing 800 ml of hot (60 °C to 80 °C) distilled water. Shake the flask to fully dissolve the tanning agents. There may be some residue if there is any insoluble matter in the sample. Leave it to cool down in a water bath at (20 ± 2) °C and add distilled water (4.1) up to the mark.

The aim is to obtain an analytical solution containing between 3,75 g and 4,25 g of substances absorbed in the hide powder. If the tanning content in the solution goes beyond these limits, repeat the analysis with a sample of suitable quantity.

7.1.3 Synthetic tanning agents in powder form

Weigh about (4 ± 0,1) g of tanning agents on an analytical balance (5.5). Add this to a 1 000 ml volumetric flask (5.10) containing 800 ml of hot (40 °C to 50 °C) distilled water. Shake the flask to fully dissolve the tanning agents. There may be some residue if there is any insoluble matter in the sample. Leave it to cool down in a water bath at (20 ± 2) °C and add distilled water (4.1) up to the mark.

In the case of breakthrough of the tanning agent (see 7.3), repeat the analysis using a lower mass. Record this deviation in the test report.

7.1.4 Synthetic tanning agents in liquid form

Weigh about (8 ± 0,1) g of tanning agents on an analytical balance (5.5). Add it to a 1 000 ml volumetric flask (5.10) containing 800 ml of hot (40 °C to 50 °C) distilled water. Shake the flask to fully dissolve the tanning agents. There may be some residue if there is any insoluble matter in the sample. Leave it to cool down in a water bath at (20 ± 2) °C and add distilled water (4.1) up to the mark.

In the case of breakthrough of the tanning agent (see 7.3), repeat the analysis using a lower mass. Record this deviation in the test report.

7.1.5 Vegetable tanning agents organic solvent extracted in powder form

Weigh about (4 ± 0,1) g of tanning agents on an analytical balance (5.5). Add this to a 1 000 ml volumetric flask (5.10) containing 800 ml of hot (40 °C to 50 °C) distilled water. Shake the flask to fully dissolve the tanning agents. There may be some residue if there is any insoluble matter in the sample. Leave it to cool down in a water bath at (20 ± 2) °C and add distilled water (4.1) up to the mark.

Select the amount in function of the quality of the extract desired. The final concentration of the analytical solution should contain about 4 g of tanning compound per litre.

7.2 Preparation of the bell

Place a layer of cotton wool at the top of the bell to prevent the hide powder from entering the capillary tube.

Put the rubber cork containing the glass capillary tube in the bell.

Weigh 7,0 g of hide powder (4.2) on a technical balance (5.6) and introduce it uniformly in the bell, pressing it down, up to the top of the rim.

Check that the hide powder is fully pressed down to ensure that it will be completely tanned.

Put the polyethylene tube in the glass capillary tube and use the Hoffman clamp (5.9).

7.3 De-tanning the analytical solution (determination of the non-tanning agents)

Place the bell containing hide powder in a beaker of suitable capacity. Fill the beaker with the unfiltered analytical solution up to the neck of the bell. When the hide powder is completely soaked, suck on the longer end of the capillary tube to create a slight depression and start siphoning the solution.

Use the Hoffman clamp (5.9) to adjust the flow of the solution so that about 8 to 10 drops of the de-tanned solution drip through per minute. The resulting solution shall be clear.

Collect a total of 90 ml in (120 ± 10) min.

The first 30 ml of the filtrate should be collected in a 50 ml glass measuring cylinder (5.14) and disposed of.

The next 60 ml should be collected in a perfectly dry 100 ml glass measuring cylinder (5.14) to determine the non-tanning agents. To control the breakthrough of tanning agents use 5 ml of the collected solution and add 0,5 ml gelatine solution (4.3). The pH of the total solution should be lower than 5. If necessary, use a few drops of formic acid to reduce the pH. A white precipitate is an indication of a breakthrough. In this case, repeat the analysis with a lower sample mass.

The solution should be at a temperature no less than 18 °C and no more than 20 °C.

Use the pipette (5.11) to transfer 50 ml of the filtered solution into a previously dried and weighed silver dish (5.2).

Place the dish on the water bath (5.3) and wait for complete evaporation.

Put the dish (5.2) in the oven (5.4) at (102 ± 2) °C to attain constant mass (about $18 \text{ h} \pm 2 \text{ h}$).

Put the dish (5.2) in the silica gel dryer (5.1) and weigh it after 15 min on analytical balance (5.5).

7.4 Determination of soluble substances

To filter the analytical solutions, use the filter system (5.12) indicated in Figure 2.

Use the cellulose acetate membranes with 0,45 µm pores (5.13).

If filtration proves awkward, use membranes with 3,0 µm pores and then pass the pre-filtered solution through the 0,45 µm membranes.

If the filtration is not possible, the solution should be centrifuged.

Collect about 100 ml of filtrate.

Use the pipette (5.11) to transfer 50 ml of the filtered solution into a previously dried and weighed silver dish (5.2).

Place the dish on the water bath (5.3) and wait for complete evaporation.

Put the dish (5.2) in the oven (5.4) at $(102 \pm 2) ^\circ\text{C}$ to attain constant mass (about $18 \text{ h} \pm 2 \text{ h}$).

Put the dish (5.2) in the silica gel dryer (5.1) and weigh it after 15 min on analytical balance (5.5).

7.5 Determination of total solids

Calibrate a silver dish (5.2) in the oven (5.4) at $(102 \pm 2) ^\circ\text{C}$ and then cool it off in the dryer (5.1), for about 15 min, down to ambient temperature.

Weigh the dish (5.2) with the analytical balance (5.5).

Add about 3 g to 5 g of the sample to the dish.

Put the dish (5.2) in the oven (5.4) at $(102 \pm 2) ^\circ\text{C}$ to attain constant mass (about $18 \text{ h} \pm 2 \text{ h}$). The heating should be done without air circulation.

Put the dish (5.2) in the silica gel dryer (5.1) and weigh it after 15 min on analytical balance (5.5).

8 Calculation and expression of the results

Calculate the percentage content of dry substances (S_{to}) (% total solid) using Equation (1).

$$S_{\text{to}} = \frac{m_1 \times 100}{m_{\text{P0}}} \quad (1)$$

where

S_{to} is the percentage content of dry substances (% total solid), in percent (%);

m_1 is the dry residue as determined at 7.5, in grams (g);

m_{P0} is the product's mass (7.5), in grams (g).

Calculate the percentage of soluble solids (S_{so}) using Equation (2).

$$S_{\text{so}} = \frac{m_2 \times 20 \times 100}{m_{\text{P1}}} \quad (2)$$

where

S_{so} is the percentage content of soluble solids, in percent (%);

m_2 is the dry residue of 50 ml of the filtered analytical solution, in grams (g);

m_{P1} is the initial mass of the product (analytical solution), in grams (g).

Calculate the percentage of non-tanning solid (S_{nt}) using Equation (3).

$$S_{\text{nt}} = \frac{m_3 \times 20 \times 100}{m_{\text{P1}}} \quad (3)$$

where

S_{nt} is the percentage of non-tanning solid, in percent (%);

m_3 is the dry residue of the non-tanning agent solution, deducted from the blank value²⁾, in grams (g);

m_{P1} is the initial weighing of the product (analytical solution), in grams (g).

Calculate the percentage of tanning agents (T) using Equation (4).

$$T = S_{so} - S_{nt} \quad (4)$$

Calculate the percentage of insoluble matter (I_M) using Equation (5).

$$I_M = S_{to} - S_{so} \quad (5)$$

Calculate the percentage of water (W) using Equation (6).

$$W = 100 - S_{to} \quad (6)$$

Calculate the ratio of tanning agent to non-tanning agent (R) using Equation (7).

$$R = \frac{T}{S_{nt}} \quad (7)$$

If there are reasons to doubt the tanning action of a product, one can avoid using the tanning agent on the test report by replacing “% tanning agent” with “% substances absorbed by hide powder”.

9 Test report

The test report shall include the following:

- a) reference to this International Standard (i.e. ISO 14088);
- b) the origin and batch of the hide powder;
- c) any deviation from the analytical procedure;
- d) percentage content of dry substances (S_{to}) (% total solid) in percent (%) to the nearest 0,1 %;
- e) percentage of soluble solids (S_{so}) in percent (%) to the nearest 0,1 %;
- f) percentage of non-tanning solid (S_{nt}) in percent (%) to the nearest 0,1 %;
- g) percentage of tanning agents (T) in percent (%) to the nearest 0,1 %;
- h) percentage of insoluble matter (I_M) in percent (%) to the nearest 0,1 %;
- i) percentage of water (W) in percent (%) to the nearest 0,1 %;
- j) ratio of tanning agent to non-tanning agent (R).

2) If you use certified hide powder, subtract the blind value on the certificate provided with the purchased batch. If instead the powder comes from another supplier or is not certified, you need to calculate the blank value according to the method in Annex B.

Annex A
(informative)

Approximate quantity of vegetable tannic extract agent in powder/solid form to be weighed

Table A.1

Tanning agents %	Approximate amount to weigh g
50	8,0
55	7,3
60	6,6
65	6,1
70	5,7
75	5,3
80	5,0
90	4,2

Annex B (normative)

Determination of hide powder blank value

Place the bell containing hide powder in a beaker of suitable capacity. Fill the beaker with distilled water up to the neck of the bell.

When the hide powder is completely soaked, suck on the longer end of the capillary tube to create a slight depression and start siphoning the solution.

Use the Hoffman clamp (5.9) to adjust the flow of the solution so that about 8 to 10 drops of the solution drip through per minute.

Collect a total of 90 ml in (120 ± 10) min.

The first 30 ml of the filtrate should be collected in a 50 ml glass measuring cylinder (5.14) and disposed of.

The next 60 ml should be collected in a perfectly dry 100 ml glass measuring cylinder (5.14) to determine the blank value.

Distilled water should be at a temperature no less than 18 °C and no more than 20 °C.

Use the pipette (5.11) to transfer 50 ml of the filtered solution into a previously dried and weighed silver dish.

Place the dish on the water bath and wait for complete evaporation.

Put it in the oven at (102 ± 2) °C to attain constant mass (about $18 \text{ h} \pm 2 \text{ h}$).

To determine the blank value, the procedure needs to be repeated at least 5 times for each batch purchased.

Calculate the average of the values obtained. The result is the "blank value".

Annex C (informative)

Suppliers of hide powder

Hide powder with certificate for analysis of substances released by hide powder in contact with distilled water (blank value) can be purchased from:

- FILK, Meissner Ring 1-5, 09599. Freiberg, Germany. www.filkfreiberg.de
- AIICA, Pla de la Massa, s/n. 08700 Igualada, Spain. www.aiica.com
- BLC Leather Technology Centre Ltd. Kinds Park Road. Moulton Park. Northampton NN3 6JD. UK. www.blcleathertech.com

British Standards Institution (BSI)

BSI is the national body responsible for preparing British Standards and other standards-related publications, information and services.

BSI is incorporated by Royal Charter. British Standards and other standardization products are published by BSI Standards Limited.

About us

We bring together business, industry, government, consumers, innovators and others to shape their combined experience and expertise into standards-based solutions.

The knowledge embodied in our standards has been carefully assembled in a dependable format and refined through our open consultation process. Organizations of all sizes and across all sectors choose standards to help them achieve their goals.

Information on standards

We can provide you with the knowledge that your organization needs to succeed. Find out more about British Standards by visiting our website at bsigroup.com/standards or contacting our Customer Services team or Knowledge Centre.

Buying standards

You can buy and download PDF versions of BSI publications, including British and adopted European and international standards, through our website at bsigroup.com/shop, where hard copies can also be purchased.

If you need international and foreign standards from other Standards Development Organizations, hard copies can be ordered from our Customer Services team.

Subscriptions

Our range of subscription services are designed to make using standards easier for you. For further information on our subscription products go to bsigroup.com/subscriptions.

With **British Standards Online (BSOL)** you'll have instant access to over 55,000 British and adopted European and international standards from your desktop. It's available 24/7 and is refreshed daily so you'll always be up to date.

You can keep in touch with standards developments and receive substantial discounts on the purchase price of standards, both in single copy and subscription format, by becoming a **BSI Subscribing Member**.

PLUS is an updating service exclusive to BSI Subscribing Members. You will automatically receive the latest hard copy of your standards when they're revised or replaced.

To find out more about becoming a BSI Subscribing Member and the benefits of membership, please visit bsigroup.com/shop.

With a **Multi-User Network Licence (MUNL)** you are able to host standards publications on your intranet. Licences can cover as few or as many users as you wish. With updates supplied as soon as they're available, you can be sure your documentation is current. For further information, email bsmusales@bsigroup.com.

BSI Group Headquarters

389 Chiswick High Road London W4 4AL UK

Revisions

Our British Standards and other publications are updated by amendment or revision.

We continually improve the quality of our products and services to benefit your business. If you find an inaccuracy or ambiguity within a British Standard or other BSI publication please inform the Knowledge Centre.

Copyright

All the data, software and documentation set out in all British Standards and other BSI publications are the property of and copyrighted by BSI, or some person or entity that owns copyright in the information used (such as the international standardization bodies) and has formally licensed such information to BSI for commercial publication and use. Except as permitted under the Copyright, Designs and Patents Act 1988 no extract may be reproduced, stored in a retrieval system or transmitted in any form or by any means – electronic, photocopying, recording or otherwise – without prior written permission from BSI. Details and advice can be obtained from the Copyright & Licensing Department.

Useful Contacts:

Customer Services

Tel: +44 845 086 9001

Email (orders): orders@bsigroup.com

Email (enquiries): cservices@bsigroup.com

Subscriptions

Tel: +44 845 086 9001

Email: subscriptions@bsigroup.com

Knowledge Centre

Tel: +44 20 8996 7004

Email: knowledgecentre@bsigroup.com

Copyright & Licensing

Tel: +44 20 8996 7070

Email: copyright@bsigroup.com



...making excellence a habit.™