

BS EN ISO 14087:2011



BSI Standards Publication

**Leather — Physical and
mechanical tests —
Determination of bending
force (ISO 14087:2011)**

bsi.

...making excellence a habit.™

National foreword

This British Standard is the UK implementation of EN ISO 14087:2011.

The UK participation in its preparation was entrusted to Technical Committee TCI/69, Footwear, leather and coated fabrics.

A list of organizations represented on this committee can be obtained on request to its secretary.

This publication does not purport to include all the necessary provisions of a contract. Users are responsible for its correct application.

© The British Standards Institution 2012

ISBN 978 0 580 68693 1

ICS 59.140.30

Compliance with a British Standard cannot confer immunity from legal obligations.

This British Standard was published under the authority of the Standards Policy and Strategy Committee on 31 January 2012.

Amendments issued since publication

Date	Text affected
------	---------------

ICS 59.140.30

English Version

Leather - Physical and mechanical tests - Determination of bending force (ISO 14087:2011)

Cuir - Essais physiques et mécaniques - Détermination de la force de flexion (ISO 14087:2011)

Leder - Physikalische und mechanische Prüfungen - Bestimmung der Biegekraft (ISO 14087:2011)

This European Standard was approved by CEN on 30 November 2011.

CEN members are bound to comply with the CEN/CENELEC Internal Regulations which stipulate the conditions for giving this European Standard the status of a national standard without any alteration. Up-to-date lists and bibliographical references concerning such national standards may be obtained on application to the CEN-CENELEC Management Centre or to any CEN member.

This European Standard exists in three official versions (English, French, German). A version in any other language made by translation under the responsibility of a CEN member into its own language and notified to the CEN-CENELEC Management Centre has the same status as the official versions.

CEN members are the national standards bodies of Austria, Belgium, Bulgaria, Croatia, Cyprus, Czech Republic, Denmark, Estonia, Finland, France, Germany, Greece, Hungary, Iceland, Ireland, Italy, Latvia, Lithuania, Luxembourg, Malta, Netherlands, Norway, Poland, Portugal, Romania, Slovakia, Slovenia, Spain, Sweden, Switzerland and United Kingdom.



EUROPEAN COMMITTEE FOR STANDARDIZATION
COMITÉ EUROPÉEN DE NORMALISATION
EUROPÄISCHES KOMITEE FÜR NORMUNG

Management Centre: Avenue Marnix 17, B-1000 Brussels

Foreword

This document (EN ISO 14087:2011) has been prepared by Technical Committee CEN/TC 289 "Leather", the secretariat of which is held by UNI, in collaboration with IULTCS "International Union of Leather Technologists and Chemists Societies".

This European Standard shall be given the status of a national standard, either by publication of an identical text or by endorsement, at the latest by June 2012, and conflicting national standards shall be withdrawn at the latest by June 2012.

Attention is drawn to the possibility that some of the elements of this document may be the subject of patent rights. CEN [and/or CENELEC] shall not be held responsible for identifying any or all such patent rights.

According to the CEN/CENELEC Internal Regulations, the national standards organizations of the following countries are bound to implement this European Standard: Austria, Belgium, Bulgaria, Croatia, Cyprus, Czech Republic, Denmark, Estonia, Finland, France, Germany, Greece, Hungary, Iceland, Ireland, Italy, Latvia, Lithuania, Luxembourg, Malta, Netherlands, Norway, Poland, Portugal, Romania, Slovakia, Slovenia, Spain, Sweden, Switzerland and the United Kingdom.

Foreword

ISO (the International Organization for Standardization) is a worldwide federation of national standards bodies (ISO member bodies). The work of preparing International Standards is normally carried out through ISO technical committees. Each member body interested in a subject for which a technical committee has been established has the right to be represented on that committee. International organizations, governmental and non-governmental, in liaison with ISO, also take part in the work. ISO collaborates closely with the International Electrotechnical Commission (IEC) on all matters of electrotechnical standardization.

International Standards are drafted in accordance with the rules given in the ISO/IEC Directives, Part 2.

The main task of technical committees is to prepare International Standards. Draft International Standards adopted by the technical committees are circulated to the member bodies for voting. Publication as an International Standard requires approval by at least 75 % of the member bodies casting a vote.

Attention is drawn to the possibility that some of the elements of this document may be the subject of patent rights. ISO shall not be held responsible for identifying any or all such patent rights.

ISO 14087 was prepared by the Physical Tests Commission of the International Union of Leather Technologists and Chemists Societies (IUP Commission, IULTCS) in collaboration with the European Committee for Standardisation (CEN) Technical Committee CEN/TC 289, *Leather*, the secretariat of which is held by UNI, in accordance with the agreement on technical co-operation between ISO and CEN (Vienna Agreement).

IULTCS, originally formed in 1897, is a world-wide organization of professional leather societies to further the advancement of leather science and technology. IULTCS has three Commissions, which are responsible for establishing international methods for the sampling and testing of leather. ISO recognizes IULTCS as an international standardizing body for the preparation of test methods for leather.

Leather — Physical and mechanical tests — Determination of bending force

1 Scope

This International Standard describes a test method for the determination of the bending force of leather.

2 Normative references

The following referenced documents are indispensable for the application of this document. For dated references, only the edition cited applies. For undated references, the latest edition of the referenced document (including any amendments) applies.

ISO 2418, *Leather — Chemical, physical and mechanical and fastness tests — Sampling location*

ISO 2419, *Leather — Physical and mechanical tests — Sample preparation and conditioning*

ISO 2589, *Leather — Physical and mechanical tests — Determination of thickness*

3 Terms and definitions

For the purposes of this document, the following terms and definitions apply.

3.1

bending force

force exerted by the specimen on the measuring bar at a specified bending angle, bending length and bending rate

3.2

bending angle

angle at which the bending force is measured

3.3

bending length

length around which the specimen is bent

NOTE The bending length is the distance between the clamping device of the specimen and the bar onto which the force of the specimen is transferred.

3.4

bending rate

rate of bending of the specimen

NOTE The bending rate is expressed in degrees per sec ($^{\circ}/s$).

3.5

compression bending

compression of the grain side or coating of the leather during bending

3.6

extension bending

extension of the grain side or coating of the leather during bending

4 Principle

The bending force is determined based on the bar method (two-point bending method). In this method, the specimen is clamped in a rotating fixture. During the rotation, the specimen exerts a force onto a bar. The force acting at a specified bending angle is measured.

5 Apparatus

5.1 Device for determining the bending force according to the bar method (two-point bending method) comprising the following.

5.1.1 Clamping mechanism, in which the specimen shall be able to be clamped vertically. The clamping jaws shall have a depth of (35 ± 1) mm and a minimum width of at least 30 mm (see Figure 1). The clamping device shall enable parallel clamping with an even pressure distribution on the specimen. It shall move smoothly and allow tightening with a torque wrench. The clamping device shall allow for affixing the specimen without it touching the bar in its initial position.

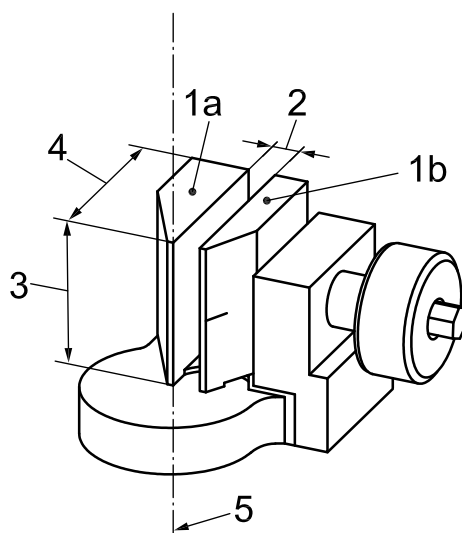

Key

- 1a fixed clamping jaws
- 1b moving clamping jaws
- 2 aperture > 6 mm
- 3 jaw width > 30 mm
- 4 jaw depth (35 ± 1) mm
- 5 pivot axis

Figure 1 — Clamping jaws

5.1.2 Means for rotating the clamping device about the pivot axis. The pivot axis is located exactly at the front edge of the fixed clamp (deviation of $\pm 0,1$ mm) (see Figure 1). Rotation shall be possible within the range of 1° to 91° with a maximum deviation of $0,1^\circ$. The rotational speed shall be able to be adjusted up to $10^\circ/\text{s}$ with an accuracy of $0,1^\circ/\text{s}$. At maximum load, the maximum deviation of the rotational speed allowed is $0,1\%$.

5.1.3 Means of measuring the bending force. The rotation of the specimen causes it to be pressed against a vertical metering bar. (See Figure 2.) The bar is connected to a load cell that allows measurement of forces up to 10 N (optionally, 1 N for very flexible materials) with a minimum resolution of 0,1 % and a maximum deviation of 0,1 %. The bar design shall exhibit a sharp edge ($R = 0,05 \pm 0,01$ mm) and a width of at least 30 mm. The weight of the bar shall not influence the measured value.

The distance between the bar and the pivot point shall be adjustable in a range from 0,1 mm to 50 mm with an accuracy of 0,1 mm. At the start of the measurement, the specimen is moved towards the bar until contact is made and a defined preliminary force is reached. This preliminary force shall be able to be adjusted with an accuracy of 1 mN. When the preliminary force is reached, the measurement shall start (angle = 0° and force = preliminary force setting). The evaluation unit shall ensure measurement of the force at one or more previously defined angles. These angles shall not be identical to the maximum angle of rotation. The measuring apparatus shall ensure that all significant parameters (force, length, speed) can be checked, calibrated and restored. It is recommended that the measured data (raw data and parameter settings) are able to be electronically archived.

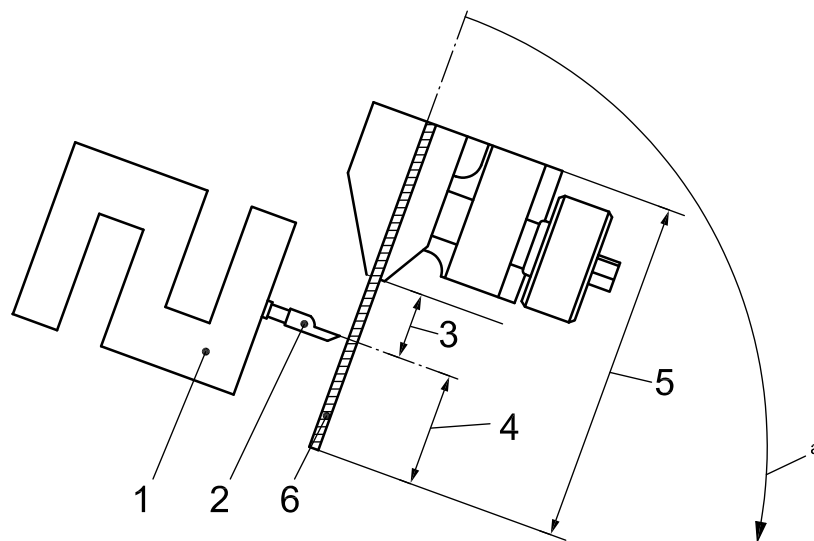

Key

- 1 load cell
- 2 vertical metering bar
- 3 bending length – adjustable
- 4 free sample length
- 5 sample length
- 6 sample
- ^a Rotating direction.

Figure 2 — Clamping jaws with specimen, load cell and bar with sharp edge

NOTE An example of a commercial source for a suitable device is given in Annex A.

5.2 Torque wrench, suitable for a range from 0,05 Nm to 0,2 Nm with an accuracy of 0,01 Nm.

5.3 Press knife, as specified in ISO 2419 for the corresponding specimen size.

6 Sampling and sample preparation

Sampling is conducted according to ISO 2418 if possible and conditioning according to ISO 2419. The dimensions of the specimens shall be taken from the relevant parameter sets (see 7.1). Other dimensions are permissible but shall be indicated in the test report. The sample is taken parallel with and perpendicular to the backbone. Other sampling angles (e.g. diagonal) are also permissible and details shall be given in the test report. If the orientation of the backbone is not known, each specimen shall be taken in two directions running perpendicular to each other. At least three specimens shall be used in each direction.

If both the compression and extension bending tests are to be conducted on the leather sample, an additional three specimens shall be used for each sampling direction.

7 Test procedure

7.1 Each specimen shall be tested only once and shall then be discarded. The specimen shall be carefully clamped into the test device such that the free-standing part of the specimen corresponds to the clamping length specified in Table 1. A torque wrench (5.2) with a setting of 0,08 Nm shall be used to tighten the clamping jaws. Then, the test shall be started with one of the specified parameter sets specified in the table below. The measurement starts at 0° when the specified preliminary force is reached. The measured forces shall be recorded at the required bending angle.

Both extension and compression bending of the grain/coated side is possible. For the extension bending test, the leather specimen shall be inserted so that the bar will press on the grain/coated side. For the compression bending test, the leather specimen shall be inserted so that the bar will press on the flesh/back side.

Three different sets of parameters can be used. If no set is specified, use set A as the standard set.

Table 1 — Parameter sets

	Parameter set		
	A (standard)	B	C
bending length (mm)	5	10	15
free clamping length (mm)	15	20	25
measurement in bending angle of (°)	60	60	60
bending up to an angle of (°)	63	63	63
bending rate (°/s)	1,5	1,5	1,5
bending rate up to preliminary force (°/s)	1,5	1,5	1,5
dimensions of sample (width × length) (mm)	30 × 50	30 × 55	30 × 60
preliminary force (mN)	3	3	3

Unless otherwise specified, calculate the mean value for all sampling directions (using all individual values). For measurements testing both bending parameters of the leather (compression and extension), mean values for each bending parameter shall be calculated. The mean values shall be given in the test report.

7.2 Measure the thickness of the leather in accordance to ISO 2589. The same specimens used for the measurement of flexural properties can be used. In this case, thickness shall be measured after the measurement of flexural properties.

8 Test report

The test report shall include the following:

- a) reference to this International Standard (i.e. ISO 14087);
- b) a description of the test specimen(s);
- c) sampling angle;
- d) mean value of the thickness;
- e) parameter set used for measurement;
- f) indication of which side was measured (compression and/or extension);
- g) average of bending force in mN with three significant digits;
- h) any deviations from this International Standard.

Annex A (informative)

Source of apparatus

An example of a suitable product available commercially is given below. This information is given for the convenience of users of this International Standard and does not constitute an endorsement by ISO of their product.

A suitable apparatus is manufactured for example by

FRANK-PTI GmbH, Auf der Aue 1, 69488 Birkenau, Germany, www.frank-pti.com.

British Standards Institution (BSI)

BSI is the national body responsible for preparing British Standards and other standards-related publications, information and services.

BSI is incorporated by Royal Charter. British Standards and other standardization products are published by BSI Standards Limited.

About us

We bring together business, industry, government, consumers, innovators and others to shape their combined experience and expertise into standards-based solutions.

The knowledge embodied in our standards has been carefully assembled in a dependable format and refined through our open consultation process. Organizations of all sizes and across all sectors choose standards to help them achieve their goals.

Information on standards

We can provide you with the knowledge that your organization needs to succeed. Find out more about British Standards by visiting our website at bsigroup.com/standards or contacting our Customer Services team or Knowledge Centre.

Buying standards

You can buy and download PDF versions of BSI publications, including British and adopted European and international standards, through our website at bsigroup.com/shop, where hard copies can also be purchased.

If you need international and foreign standards from other Standards Development Organizations, hard copies can be ordered from our Customer Services team.

Subscriptions

Our range of subscription services are designed to make using standards easier for you. For further information on our subscription products go to bsigroup.com/subscriptions.

With **British Standards Online (BSOL)** you'll have instant access to over 55,000 British and adopted European and international standards from your desktop. It's available 24/7 and is refreshed daily so you'll always be up to date.

You can keep in touch with standards developments and receive substantial discounts on the purchase price of standards, both in single copy and subscription format, by becoming a **BSI Subscribing Member**.

PLUS is an updating service exclusive to BSI Subscribing Members. You will automatically receive the latest hard copy of your standards when they're revised or replaced.

To find out more about becoming a BSI Subscribing Member and the benefits of membership, please visit bsigroup.com/shop.

With a **Multi-User Network Licence (MUNL)** you are able to host standards publications on your intranet. Licences can cover as few or as many users as you wish. With updates supplied as soon as they're available, you can be sure your documentation is current. For further information, email bsmusales@bsigroup.com.

BSI Group Headquarters

389 Chiswick High Road London W4 4AL UK

Revisions

Our British Standards and other publications are updated by amendment or revision.

We continually improve the quality of our products and services to benefit your business. If you find an inaccuracy or ambiguity within a British Standard or other BSI publication please inform the Knowledge Centre.

Copyright

All the data, software and documentation set out in all British Standards and other BSI publications are the property of and copyrighted by BSI, or some person or entity that owns copyright in the information used (such as the international standardization bodies) and has formally licensed such information to BSI for commercial publication and use. Except as permitted under the Copyright, Designs and Patents Act 1988 no extract may be reproduced, stored in a retrieval system or transmitted in any form or by any means – electronic, photocopying, recording or otherwise – without prior written permission from BSI. Details and advice can be obtained from the Copyright & Licensing Department.

Useful Contacts:

Customer Services

Tel: +44 845 086 9001

Email (orders): orders@bsigroup.com

Email (enquiries): cservices@bsigroup.com

Subscriptions

Tel: +44 845 086 9001

Email: subscriptions@bsigroup.com

Knowledge Centre

Tel: +44 20 8996 7004

Email: knowledgecentre@bsigroup.com

Copyright & Licensing

Tel: +44 20 8996 7070

Email: copyright@bsigroup.com



...making excellence a habit.™