

# **Protective clothing — Mechanical properties — Test method for the determination of the resistance to puncture and dynamic tearing of materials**

The European Standard EN ISO 13995:2000 has the status of a  
British Standard

ICS 13.340.10

## National foreword

This British Standard is the official English language version of EN ISO 13995:2000. It is identical with ISO 13995:2000.

The UK participation in its preparation was entrusted by Technical Committee PH/3, Protective clothing, to Subcommittee PH/3/1, Clothing for protection against general hazards, which has the responsibility to:

- aid enquirers to understand the text;
- present to the responsible international/European subcommittee any enquiries on the interpretation, or proposals for change, and keep the UK interests informed;
- monitor related international and European developments and promulgate them in the UK.

A list of organizations represented on this committee can be obtained on request to its secretary.

### Cross-references

Attention is drawn to the fact that CEN and CENELEC Standards normally include an annex which lists normative references to international publications with their corresponding European publications. The British Standards which implement international or European publications referred to in this document may be found in the BSI Standards Catalogue under the section entitled “International Standards Correspondence Index”, or by using the “Find” facility of the BSI Standards Electronic Catalogue.

A British Standard does not purport to include all the necessary provisions of a contract. Users of British Standards are responsible for their correct application.

**Compliance with a British Standard does not of itself confer immunity from legal obligations.**

### Summary of pages

This document comprises a front cover, an inside front cover, the EN ISO title page, pages 2 to 28, an inside back cover and a back cover.

The BSI copyright notice displayed in this document indicates when the document was last issued.

### Amendments issued since publication

Amd. No.	Date	Comments

This British Standard, having been prepared under the direction of the Health and Environment Sector Committee, was published under the authority of the Standards Committee and comes into effect on 15 February 2001

EUROPEAN STANDARD

**EN ISO 13995**

NORME EUROPÉENNE

EUROPÄISCHE NORM

December 2000

---

ICS 13.340.10

English version

**Protective clothing - Mechanical properties - Test method for the  
determination of the resistance to puncture and dynamic tearing  
of materials (ISO 13995:2000)**

Vêtements de protection - Propriétés mécaniques -  
Méthode d'essai pour la détermination de la résistance à la  
perforation et au dynamique des matériaux (ISO  
13995:2000)

Schutzkleidung - Mechanische Eigenschaften -  
Prüfverfahren zur Bestimmung des Widerstandes gegen  
Durchstoßen und dynamisches Weiterreißen von  
Materialien (ISO 13995:2000)

This European Standard was approved by CEN on 8 April 2000.

CEN members are bound to comply with the CEN/CENELEC Internal Regulations which stipulate the conditions for giving this European Standard the status of a national standard without any alteration. Up-to-date lists and bibliographical references concerning such national standards may be obtained on application to the Management Centre or to any CEN member.

This European Standard exists in three official versions (English, French, German). A version in any other language made by translation under the responsibility of a CEN member into its own language and notified to the Management Centre has the same status as the official versions.

CEN members are the national standards bodies of Austria, Belgium, Czech Republic, Denmark, Finland, France, Germany, Greece, Iceland, Ireland, Italy, Luxembourg, Netherlands, Norway, Portugal, Spain, Sweden, Switzerland and United Kingdom.



EUROPEAN COMMITTEE FOR STANDARDIZATION  
COMITÉ EUROPÉEN DE NORMALISATION  
EUROPÄISCHES KOMITEE FÜR NORMUNG

**Management Centre: rue de Stassart, 36 B-1050 Brussels**

## Contents

Foreword.....	3
Introduction .....	3
1 Scope .....	5
2 Terms and definitions.....	5
2.1 Test specimen mounting block .....	5
2.2 Tearing blade.....	5
3 Requirements .....	5
3.1 Use of this standard .....	5
4 Test apparatus and procedures .....	7
4.1 Principle of the puncture and dynamic tear test .....	7
4.2 Types of tear and their measurement.....	7
4.3 Performance levels .....	7
4.4 Test apparatus.....	8
4.5 Falling mass - blade holding block .....	8
4.6 The tearing blade .....	8
4.7 The test specimen mounting block and clamps.....	9
4.7.1 Dimensions of the test specimen mounting block.....	9
4.7.2 The test specimen clamping system .....	9
4.8 Preparing the apparatus.....	9
4.9 Preparation of test specimens.....	10
4.10 Mounting the test specimens .....	10
4.11 Carrying out a test .....	10
4.12 Classification of results .....	11
4.13 Test report .....	12
Annex A (informative).....	13
Informative annex on the specification of puncture and dynamic tear tests on materials and clothing. ....	13
A.1 Introduction .....	13
A.2 Scope .....	13
A.3 Use of this European Standard .....	13
A.4 Hazard identification - choice of test method .....	13
A.4.1 Puncture and propagating tear.....	13
A.4.2 Puncture.....	13
A.4.3 Impact cut, stab.....	13
A.4.4 Sliding cut.....	14
A.4.5 Impact abrasion.....	14
A.4.6 Shearing, puncturing and tear .....	14
A.4.7 Tearing or bursting .....	14
A.4.8 Summary of test method choice .....	14
A.5 Risk analysis .....	15
A.5.1 Threat identification and quantification .....	15
A.5.2 Estimation of potential harm .....	15
A.5.3 Risk level estimation .....	16
A.6 Performance criteria .....	17
A.7 Specification of performance levels .....	17
A.8 Special conditions and deviation from the method in this European Standard .....	17
A.8.1 Area of hole or tear length .....	17
A.8.2 Pre-conditioning.....	18
A.8.3 Special test conditions.....	18
Annex ZA (informative) .....	28
Clauses of this European Standard addressing essential requirements or other provisions of EU Directives .....	28

## Foreword

The text of EN ISO 13995:2000 has been prepared by Technical Committee CEN/TC 162 "Protective clothing including hand and arm protection and lifejackets", the secretariat of which is held by DIN, in collaboration with Technical Committee ISO/TC 94 "Personal safety - Protective clothing and equipment".

This European Standard shall be given the status of a national standard, either by publication of an identical text or by endorsement, at the latest by June 2001, and conflicting national standards shall be withdrawn at the latest by June 2001.

This European Standard has been prepared under a mandate given to CEN by the European Commission and the European Free Trade Association, and supports essential requirements of EU Directive(s).

For relationship with EU Directive(s), see informative Annex ZA, which is an integral part of this standard.

According to the CEN/CENELEC Internal Regulations, the national standards organizations of the following countries are bound to implement this European Standard: Austria, Belgium, Czech Republic, Denmark, Finland, France, Germany, Greece, Iceland, Ireland, Italy, Luxembourg, Netherlands, Norway, Portugal, Spain, Sweden, Switzerland and the United Kingdom.

## Introduction

This European Standard test method is based on ASTM D 2582-90, "Standard test method for puncture-propagation tear resistance of plastic film and thin sheeting". The test has been modified to make it applicable to strong woven and knitted fabrics, coated fabrics and leather. The test is designed to assess the resistance to snagging and tearing of materials used for protective clothing. It is important to know the puncture and dynamic tear resistance of material used for protective clothing that is intended to be used in hazardous situations where the clothing forms a barrier between the wearer and the hazard, and breaching of the barrier can result in harm and the level of risk of harm is related to the size of hole resulting from the puncture and tear. Such clothing includes chemical and biological barrier clothing, spray suits, foul weather clothing and firefighting clothing.

Dynamic tearing of materials following puncture by a spike is a complex process. The test given in this European Standard has been devised to provide standard conditions under which materials can be compared. Experience with materials of known resistance will enable product standards writers and clothing designers to specify appropriate performance levels for particular end-uses. The standard provides for four performance levels.

It has been assumed in the drafting of this European Standard that the execution of its provisions is entrusted to appropriately qualified and experienced people, for whose guidance it has been prepared. The apparatus described should only be used by competent persons and requires safeguards to prevent, as far as is reasonably practicable, injury to the operator and other persons.

## 1 Scope

This European Standard specifies a test method for the determination of the resistance to puncture and dynamic tearing of protective clothing materials which are used in situations where snagging and tearing could result in unacceptable damage to the clothing or danger to the wearer through loss of integrity of a barrier. It is intended that the performance levels determined will be of use in specifying materials for use in situations where the risk of harm is related to the size of puncture and tear that may occur in accidents.

## 2 Terms and definitions

For the purposes of this European Standard, the following terms and definitions apply:

### 2.1 Test specimen mounting block

A solid block of metal or plastic to which the test specimen is clamped for testing.

### 2.2 Tearing blade

A blunt blade projecting from the falling mass which punctures and tears the test specimen.

**NOTE:** The hard steel tearing blade has a ground wedge shaped end that has a radius of curvature so that it is not sharp, but will puncture test materials. The main body of the blade is 3 mm thick and the lower surface is half round. This lower surface causes the blunt tear in the test specimen that is measured in the test. This blade performs the same function as the spike in ASTM D 2582-90, but it is more rigid so is capable of withstanding greater forces.

## 3 Requirements

### 3.1 Use of this standard

This European Standard describes a method for determining the resistance to puncture and dynamic tearing of materials. When it is cited as a test method in a specific product standard that standard shall contain the necessary information to permit the application of this European Standard to the particular products. The standard citing this European Standard shall include at least the following:

- a) Normative reference to this European Standard;
- b) A description of the samples to be tested, their origin in sheet materials or finished PPE (Personal Protective Equipment) products, their method of preparation and pre-treatment, if any, and the permitted size range of the samples;
- c) Details of any additions to, or deviations from the method described in this European Standard;
  - Details of any specific clamping and stretching methods to be used with the test specimens ;
  - The energy(s) and velocity(s) of impacts to be used in the test;
  - The orientation of the impacts relative to a specified axis of the test specimens ;
  - The number of tests to be performed:
  - Details of any specific techniques to be used in measuring tear lengths in particular materials or in materials for particular applications;
- d) Additional contents of the test report to be provided:

- The performance requirements for the product, and associated "levels". The performance required shall be given as either a performance level as defined in this European Standard, or as "a mean tear length not more than xx mm and a largest single value of not more than yy mm when tested according to zz";
- The area of the product that is to meet the requirements.

Information and guidance on using this European Standard in a product standard are given in the informative Annex A.



## 4 Test apparatus and procedures

### 4.1 Principle of the puncture and dynamic tear test

A test specimen of fabric or leather is clamped securely to a solid block that is shaped so that the main part of the test specimen is vertical. The upper part of the block is machined to be a quadrant so that the test specimen lies back on it and presents a curved face upwards towards the tearing blade attached to a falling mass that is dropped onto the test specimen. The tearing blade is sharpened on its end so that it punctures the curved part of the test specimen. The rounded lower surface of the blade tears downwards into the vertical part of the test specimen until the energy in the falling mass is dissipated. The vertical face of the block has a slot machined into it so that the end of the blade is in the block and the middle part of the blade causes the tearing.

It is found on very strong materials that the puncturing process by the sharpened end of the blade contributes less than 5 mm to the total tear length. With weak materials the effect is less. Choosing an end point or pass/fail value of 40 mm ensures that the main property measured is the dynamic tear resistance of the punctured material. The tear length is the vertical dimension of the hole made by the blade. It may be appropriate to specify a lower tear length for assessing materials to be used where tearing of products would expose the wearers to hazards, see Annex A.

### 4.2 Types of tear and their measurement

The following types of tear are commonly caused:

- a) A vertical slit tear in which the blade breaks horizontal fibres in the test specimen;
- b) A "V" tear which has two legs diverging from the puncture point. In woven fabrics the legs may proceed at 90° to the warp and weft fibres giving an angle between the legs of 90°. In leather, composite materials and unsupported plastics the angle between the legs is often about 30°;
- c) A horizontal tear in which a tear propagates horizontally from the puncture point along a line of weakness. This is found sometimes in one orientation of testing of coated knitted fabrics. When test specimens of such material are cut at 90° to the orientation giving this type of tear, the result is usually a very long vertical slit tear.
- d) Complex tears combining various properties of the above tears. Some warp knits give V tears with one vertical and one 45° leg, or one vertical and one horizontal leg.

For all types of tear the tear length is the vertical dimension of the hole made by the blade. The hole is measured with the blade in situ if the hole is long enough. This ensures the dynamic rolling up of the material in V tears is consistently treated. Similarly the stretching effect of the mass of the block on the test specimen will be consistent for each falling mass. If the tear is shorter than the vertical height of the blade, the blade is lifted out and the hole measured while the test specimen is still clamped. In materials with unusual responses and a particular weakness in one orientation, test samples should be prepared that permit the "worst case" tear to be produced and measured.

The final falling mass position is not a reliable indicator of tear length in all materials as very elastic fabrics stretch during the test, and the upper edge of the hole will be drawn downwards. The hole length would be over estimated by comparing the position of the falling mass when it first contacts the test specimen and its final position. The falling mass resting in the tear will increase its measured length in compliant materials and this should be considered when citing this European Standard.

### 4.3 Performance levels

The performance level reached by a material is determined as described below. It is based on the mean value of the tear lengths in all orientations of test, if these are similar, or on the mean value of the tear lengths at the worst orientation if this value is more than 50% greater than the value from the orientation giving the smallest tear length.

#### 4.4 Test apparatus

The test apparatus shall consist of a rigid heavy base on which a test specimen mounting block and a falling mass guidance system are mounted, see figure 1. The guidance system shall consist of two vertical polished steel rods at least 15 mm in diameter with their centres  $(100 \pm 2)$  mm apart. The steel rods shall be sufficiently long to accommodate a drop height of 750 mm between the base of the tearing blade and the puncture point on the test specimen. A dropping mechanism shall be provided such as an electromagnet to hold the falling mass in its initial position. Its height shall be adjustable so that the energy losses due to friction may be allowed for and the appropriate energy of impact achieved. A means of measuring the impact velocity of the falling mass and blade shall be provided.

#### 4.5 Falling mass - blade holding block

The proportions and dimensions of the falling mass blade holding block are shown in figure 2. Four blocks should be provided that with the tearing blade fitted have the following masses:

No 1	$(250 \pm 10)$ g
No 2	$(500 \pm 10)$ g
No 3	$(1000 \pm 20)$ g
No 4	$(2000 \pm 40)$ g

The blade holding block may be constructed of any convenient rigid material. Higher mass blocks may be provided by adding weights to lighter ones provided the block remains within the dimensions given in figure 2.

The blocks shall be provided with low friction guides. Plastic tubes running through the block, or slides of at least 20 mm length in the top and bottom of the block, may be used. The clearance on the guidance rods shall be  $(1 \pm 0,5)$  mm. Systems using linear bearings or wheels have been found to absorb significant amounts of energy during the tearing action because of the moment between the block and the guidance rods. A system of plastic tubes and a light oil on the guidance rods has been found to give consistent results.

#### 4.6 The tearing blade

The position and overall dimensions of the tearing blade in relation to the holding block are shown in figure 2. The blade shall be made of steel. It shall preferably have a hardness of 58 HRC (Rockwell hardness scale C). It shall be rigidly attached to the holding block. Its lower edge shall be horizontal, and shall have a radius of  $(1,5 \pm 0,1)$  mm, and level with the lower edge of the blade holding block, see figure 2. The blade height shall be  $(10 \pm 0,1)$  mm for the end 10 mm. The top surface shall be flat and parallel to the lower surface. The vertical end of the blade shall be ground to an angle of  $(60 \pm 3)^\circ$  and radiused at  $(0,2 \pm 0,1)$  mm.

## 4.7 The test specimen mounting block and clamps

The test specimen mounting block shall be made of metal or a hard plastic. The clamps shall be made of steel and the bolts and fixings shall be hardened steel. The block and clamps are designed to accept material samples 110 mm wide and 180 mm to 200 mm long. The test specimens are clamped across the top and down the sides.

The test specimen mounting block shall be provided with a means of fixing it firmly to the base of the apparatus. The fixing system shall allow the block to be positioned accurately with respect to the tearing blade. The blade shall enter the slot in the block by  $(10 \pm 0,5)$  mm and shall be central in the slot  $\pm 0,5$  mm.

### 4.7.1 Dimensions of the test specimen mounting block

The test specimen mounting block is shown in figure 3. It shall be  $(250 \pm 10)$  mm high, at least 200 mm wide, and at least 100 mm front to back. The top of the front face shall be machined to be a quadrant of  $(100 \pm 1)$  mm radius. A slot  $(8 \pm 0,5)$  mm wide and  $(15 \pm 1)$  mm deep shall be machined in the centre of the front face.

### 4.7.2 The test specimen clamping system

The clamping system is shown in figure 4. Five steel clamps shall be provided that can be drawn onto the test specimen mounting block by 14 bolts as shown in the figure. The clamps shall have five parallel ridges with angles of  $(60 \pm 3)^\circ$  and a pitch (separation) of  $(3 \pm 0,05)$  mm. These ridges shall be machined to stand out from the inner clamp faces. The ridges shall fit into matching grooves machined into the front face of the test specimen mounting block. The positions of these grooves are shown in figure 3. The surface of the test specimen mounting block beneath the upper transverse clamp may be machined flat to accept a flat clamp more easily. This is shown in figure 4. Set screws shall be provided to permit adjustment of the clamps for materials of different thickness. The remaining normative dimensions of the clamping system are given in the legend to figure 4.

## 4.8 Preparing the apparatus

The test specimen mounting block shall be bolted to the base in the appropriate position (4.7). An appropriate blade holding block shall be put on the guidance system and its free running checked. Test drops shall be made and the velocity of the block measured at the point the end of the tearing blade begins to enter the slot on the test specimen mounting block. The dropping height shall be adjusted so that the mean velocity in five consecutive drops is such that the block and blade have a kinetic energy within the required range, below, taking into account the exact mass of the block.

For the 250 g block the energy range shall be 1,6 J - 1,8 J

For the 500 g block the energy range shall be 3,3 J - 3,5 J

For the 1000 g block the energy range shall be 6,6 J - 7,0 J

For the 2000 g block the energy range shall be 13,4 J - 14,0 J

#### 4.9 Preparation of test specimens

Whenever possible test specimens for the assessment of materials shall be cut from rolls of material, whole skins or half hides. The long axis of the roll (machine direction), or the head to tail axis of a skin shall be established. Equal numbers of test specimens orientated along the long axis, across the long axis and at 45° to the long axis shall be cut (110 ± 5) mm wide and (200 ± 20) mm long. The long axis shall be marked in each specimen. If washing or dry cleaning pre-treatments are specified in the product standard citing this European Standard, intact products, or large material specimens shall be pre-treated before test specimens are cut from them.

If finished PPE products are the source of the test specimens, the construction materials should be examined to determine an identifiable axis. If this is impossible an axis related to the product construction shall be chosen and recorded. Test specimens should be taken from a number of PPE items, as required by the product standard.

The test specimens shall be conditioned at (20 ± 2)°C and a relative humidity of (65 ± 5)%, for at least 24 h before testing. Testing shall be carried out in the conditioning environment or within 5 min of withdrawing the specimens from the conditioning environment.

#### 4.10 Mounting the test specimens

The clamps of the specimen mounting block shall be loosened off and pushed clear of the block. A specimen is fed under the clamps. The horizontal clamp is held up as the specimen is pushed under it. When the specimen is equally under all the clamps the bolts shall be done up in the order shown in figure 5, except that the order is not normally critical after bolt 8. Light pressure with the finger tips flat on the specimen should be used while doing up bolts 1, 2, 5, 7, and 8, in the directions of the arrows in the figure. Firmer pressure should be used while doing up bolt 6 to ensure even flattening of the specimen.

The specimen should not be stretched during the mounting, but after the clamps are all tightened it should be flat and taught. To ensure even clamping the set screws of the vertical straight and curved clamps should be adjusted to just touch the face of the block when the clamps are firm before the final tightening. The set screws in the horizontal clamping bar should be set to ensure the nuts on the studs pull the clamp evenly onto the test specimen and the ridges engage in the grooves equally. In all cases the thicker the test specimen the longer the protrusion of the set screws should be.

#### 4.11 Carrying out a test

The blade holding block shall be released by the electromagnet from the height determined in 4.8, onto a test specimen mounted as described in 4.10. The length of tear shall be measured with callipers accurate to 0,1 mm. For all tears longer than 15 mm, the distance between the top of the tearing blade and the top of the tear is measured while the block and blade are at rest supported by the test specimen. A value of 10 mm is added to the measured value to give the tear length. For tears shorter than 15 mm the blade holding block shall be raised, and the blade disengaged from the test specimen. The whole tear length shall then be measured with the callipers while the test specimen is still clamped in the machine.

The test specimen shall be removed from the clamps and examined. The clamps should have left even marks on the specimen. There should be no evidence of any slippage and no fibres should have pulled partly or completely out of the clamps.

**NOTE 1:** If the specimen shows evidence of slippage the result should normally be rejected. That will be except in the cases of some very strong fabrics such as plain weave monofilament aramid fabrics which show holes or tears of only 10 mm to 20 mm with the 2000 g block. These fabrics have a low compliance so high yarn tensions occur on impact in the test. The slipping fibres are difficult to clamp. Results of 10 mm to 20 mm are well within the highest performance level so the results can be accepted despite some yarn slippage. Slippage should be noted in the test report.

At least two test specimens cut in each orientation shall be tested. The mean tear length in tests in each orientation shall be calculated. If the largest value is more than 1,5 times the smallest value for further test specimens cut in the same orientation as those giving the largest value shall be tested. All the results in this orientation shall be combined to give an overall result. If the largest value is not more than 1,5 times the smallest value, the six results shall be averaged to give the overall result.

**NOTE 2:** Normally tears remain within the area of the specimen and do not reach the edge. Materials that tear to the edge in one test orientation usually give long tears in at least one other orientation, and do not meet the requirements for the performance level being assessed. If necessary additional test specimens should be prepared for testing in particular orientations if it is considered a weakness in the material has not been fully evaluated.

#### 4.12 Classification of results

The overall result obtained in 4.11 shall be used to classify the materials tested to different performance levels. To meet the requirement for a particular performance level, the test material shall have a mean tear length less than the length specified in the standard citing this standard under the particular conditions. Performance levels should be expressed as in Table 1.

**Table 1 - Performance levels**

<b>Mass of blade holding block and blade</b>	<b>Energy of impact</b>	<b>Mean tear length specified in the citing standard</b>	<b>Performance level</b>
<b>g</b>	<b>J</b>	<b>mm</b>	
250	1,7	> XX	FAIL
250	1,7	< XX	1
500	3,4	< XX	2
1000	6,8	< XX	3
2000	13,6	< XX	4

For each of the required sequences of measurements performed in accordance with this standard a corresponding estimate of the uncertainty of the final result shall be determined. This uncertainty ( $U_m$ ) shall be given in the test report in the form  $U_m = \pm X$ . It shall be used in determining whether a "Pass" performance has been achieved. For example if the final result plus  $U_m$  is above the pass level when the requirement is that a certain value shall not be exceeded, the sample shall be considered to have failed

#### 4.13 Test report

The test report shall contain at least the following:

- a) Reference to this European Standard and to the standard or other documents citing this standard;
- b) Identification of the test material;
- c) Any pre-treatment or conditioning;
- d) Any deviations from the laid down procedures;
- e) The blade holding block weight used, and the individual tear lengths obtained at stated orientations;
- f) The mean of the results at all orientations, or the mean of the results in the worst orientation, if this was more than 1,5 times the value in the best direction;
- g) Whether any slippage of test specimens or other deviations occurred;
- h) The value of  $U_m$  (the uncertainty of measurement) for the determination of the overall result;
- i) The performance level reached by the material determined according to the standard or other document citing this standard

## **Annex A (informative)**

# **Informative annex on the specification of puncture and dynamic tear tests on materials and clothing.**

### **A.1 Introduction**

The test method in this European Standard may be used to assess the resistance to puncturing and dynamic tearing of woven, knitted, coated, membrane, laminate or leather materials used in personal protective equipment (PPE).

The test method provides information about the relative resistance of materials to damage in snagging incidents. In such incidents the PPE may catch on a nail or obstruction, is punctured and then is torn. In non-resistant garments a large hole may be caused. In resistant garments a puncture may not be followed by any tearing so damage is limited, and the ingress of water, dirt or chemicals is limited. The test provides information about the likelihood of tearing following puncturing.

### **A.2 Scope**

The information in this annex is provided to assist users of this European Standard apply it to particular problems. Information about the results obtained with the test method are given. An interpretation of the meaning of the performance levels is given.

### **A.3 Use of this European Standard**

When this European Standard is cited a number of parameters have to be specified as listed under requirements clause 4. It should also be considered what additional or alternative test methods would provide the required data. It has been assumed in drawing up this European Standard that it will be used most frequently in PPE product standards.

### **A.4 Hazard identification - choice of test method**

The choice of test methods for PPE will depend on the hazards foreseen. Of the general puncture/ tear type hazard, six types have been identified and the application of particular test methods to them is given below.

#### **A.4.1 Puncture and propagating tear**

Sharp spikes, nails, thorns, needles, sharp metal corners, rough masonry and barbed wire which the PPE contacts at a shallow angle can cause puncturing and tearing. This is often referred to as "snagging". Resistance to this type of damage is measured in this European Standard.

#### **A.4.2 Puncture**

Sharp spikes, nails, thorns or needles which the PPE contacts with a force directly on the point of the object can perforate it. This is a pure puncture hazard and may be measured according to EN 863 : 1995 Protective clothing - mechanical properties – Test method: puncture resistance.

#### **A.4.3 Impact cut, stab**

Sharp points and edges such as on pointed knives, broken glass and razor wire which the PPE contacts with a force directly on the sharp point and cutting edge can produce cuts at low forces. This is an impact cut hazard. The resistance to impact cutting of clothing materials may be measured according to EN 1082-3 : 2000 "Protective

clothing - Gloves and arm guards protecting against cuts and stabs by hand knives - Part 3: Impact cut test for fabric, leather and other materials".

#### **A.4.4 Sliding cut**

Sharp edges such as on sheet metal parts, swarf, knives, glass, castings and bladed tools against which the PPE may be drawn can cause a direct cut without prior perforation. Resistance to sliding cuts may be measured according to EN ISO 13997:1999 " Protective clothing - Mechanical properties - Determination of resistance to cutting by sharp objects (ISO 13997:1999)".

#### **A.4.5 Impact abrasion**

Sharp points of limited height such as the surfaces of concrete, rocks and roads can cause rapid abrasion and loss of material in high force sliding impacts such as during in-line skaters' falls, climbers' falls and motorcyclists' accidents. This loss of material can result in holing and subsequent tearing of clothing. The abrasion resistance of materials can be assessed by the method in Woods, R.I. "Belt abrader impact abrasion testing of leathers and fabrics used in motorcycle riders' clothing". Performance of Protective Clothing: Fifth Volume, ASTM STP 1237, James S. Johnson and S.Z. Mansdorf. Eds. American Society for Testing and Materials, Philadelphia, USA, 1996. The method in this European standard can be used to assess the tearing resistance that such products would have after a hole has been made in them by abrasion.

#### **A.4.6 Shearing, puncturing and tear**

Blunt points or cylinders such as football boot studs make oblique impacts with the shins of other players and can directly cause injuries. This specialised and severe puncture and tear hazard is addressed by the test method in prEN 13061 : 1997 Protective clothing - Shin guards for soccer players - Requirements and test methods.

#### **A.4.7 Tearing or bursting**

Various well established tear tests are used on woven fabrics and leathers. They are not generally applicable to very elastic fabrics or knitted materials. The tests are performed at low velocity. Bursting tests are often used on coated and knitted materials. Bursting tests do not examine the properties of the materials after a hole has been formed, but they do provide a method of comparing the tensile strength of all materials. They can be performed on woven fabrics and leathers as satisfactorily as on knitted materials.

#### **A.4.8 Summary of test method choice**

##### **A.4.8.1 When to choose the puncture and dynamic tearing test**

The puncture and dynamic tearing test in this European Standard will be highly appropriate in the following circumstances:

- a) When the hazard is one of simultaneous puncturing and tearing;
- b) When a risk analysis shows that the consequences of a tear propagating from a puncture are serious;
- c) When the hazard involves relative motion between the spike and the PPE above  $1 \text{ m.s}^{-1}$ ;
- d) When the material is highly compliant and stretches rather than tears in actual incidents;
- e) When the material is a knit, a mesh, or a non-woven that is difficult to test in a conventional tear test;
- f) When a coating on a woven, knitted, or non-woven fabric contributes positively and significantly to its resistance to snagging damage and to its resistance to puncturing and tearing;
- g) When the material is an unsupported membrane;
- h) When materials the method is uniquely able to test are being compared with materials that can be adequately tested by other methods;



i) When a product standard needs to allow for both materials falling into c to g above and for other materials, without being unnecessarily restrictive.

#### **A.4.8.2 When the puncture and dynamic tearing test will not be appropriate**

It may not be appropriate to specify the puncture and dynamic tearing test in the following circumstance:

- a) When the hazard is predominantly one described in A.3.2 to A.3.6;
- b) When any hole or tear in the material would be extremely dangerous and resistance to the initiating puncture or cut are therefore critical;
- c) When the resistance to tearing is much greater than the resistance to puncturing and the integrity of the barrier is important.

### **A.5 Risk analysis**

A risk analysis by the authors of any standard citing this one is regarded as essential. The following steps might be involved.

#### **A.5.1 Threat identification and quantification**

The primary threat to the integrity of the PPE is the object that causes the initial puncture and against which the tearing is done during subsequent relative movement of the PPE and the puncturing or snagging object. The characteristics of the threat are:

- The sharpness of the puncturing object.
- The sharpness of the tearing edge. (If it is sharp enough to cut the PPE, the puncture and dynamic tearing test is inappropriate.)
- The relative velocity of the object and the PPE, and the mass of the body part covered by the PPE. The energy of the impact.
- The energy that will need to be expended to halt the relative movement of the object and the PPE. This might be by arresting the object or by arresting the PPE. The latter might involve arresting the movement of the user or just the PPE if this is able to move on the user.
- The responses of the user to the impact, such as reflex control when a hand slips during forceful use of a spanner.
- The frequency of occurrence of the threat.

If there is not sufficient experience available to indicate what strength of material is needed to resist the particular threat, it will be necessary to measure the forces that might exist in the potential accident and to relate these to the performance criteria. It has been estimated from measurements and calculation that the force between a spike and a boot upper may be over 800 N, but between a glove and an object in a glove box may be below 20 N.

#### **A.5.2 Estimation of potential harm**

The decision to require PPE to have a particular level of a measured mechanical characteristic depends on the estimate of harm that may occur if the PPE has a lower strength than that specified. The following types of harm have been identified that could follow from inadequate puncture and dynamic tear resistance.

- a) Immediate potentially fatal harm such as when an inflated buoyancy aid or life jacket is torn;
- b) Immediate and obvious, or delayed and insidious severe harm to the user when a barrier material is breached while the PPE is in anticipated and intended contact with a harmful material, or subsequently the user is exposed to such a material. This could occur with nuclear, chemical or biological protective suits, spray suits and gloves;

- c) Possible harm when the garment is used as a protection against infrequent and accidental contact with substances as above. Harm occurs when breaching and hazardous material contact are simultaneous or when they are sequential. The harm may be cumulative as for example when pesticides penetrate through small tears and build up inside a spray suit;
- d) Immediate and obvious harm of varying severity when the breaching hazard physically injures the wearer of the PPE through the hole. This might be when a sharp spike sticking out of a refuse sack catches on the worker's leg as it swings past the sack, or an object on the ground tears through a boot upper into the wearer's foot or ankle;
- e) Delayed and possibly insidious harm when damage to the PPE reduces its effectiveness in future incidents;
- f) Moderate to severe potential harm when, for example, the breaching of the outer layer of a fireman's suit leads directly to burns or to water entry and scalds later on during the same incident, or when a dry immersion suit is torn and allows water ingress;
- g) Slight to moderate harm when the breaching of the PPE reduces its immediate effectiveness such as in tearing of thermally protective and/or waterproof foul weather clothing while in use in bad weather;
- h) Potential future harm of, when for example, high visibility garments become ineffective through tearing and loss of visible area.

### **A.5.3 Risk level estimation**

The overall risk level depends on the severity of the threat, the frequency of occurrence of the threat, the level of potential harm and the frequency or probability of the presence of the harmful substance or situation. The following should be considered:

- The frequency of exposure to the mechanical hazard;
- The severity of the mechanical hazard;
- The frequency of exposure to substances or situations that cause harm if the PPE is breached;
- The severity of harm that the substances or situations may cause.

The level of risk is related to the type of work being carried out, the level of training of the workers and the amount of exposure to situations where the puncture hazards exist. Fire fighters and accident recovery personnel frequently encounter situations where they are working in conditions of low visibility and in confined spaces, and where the risk of snagging on objects is high. In a few situations damage to the PPE may be life threatening, but in others may cause only slight injury or discomfort.

Laboratory workers in the chemical, biological and nuclear industries should have a lower risk of being snagged on protruding objects, but the consequences of exposure to the environment may carry a high probability of being seriously harmed or killed. Depending on the circumstances, immediate injury may not be obvious because the effects of exposure to some chemical and biological substances take time to become evident. This may not necessarily even be in the exposed person but may be passed on through genetic or birth defects to their children.

The level of risk may be altered by the obviousness of the occurrence of tearing of the PPE, and by the possibilities for taking immediate remedial action. The risk level therefore may be reduced by frequent inspection and testing of PPE, or by the use of alarmed PPE as worn in the nuclear industry, which signals to the wearer when the barrier is breached. The level of risk will be increased if small tears are ignored by poorly trained workers, and chemicals are allowed to seep in and accumulate in linings and inner clothing. However in this case stronger PPE might actually increase the risk of harm, because being stronger it could be used for longer, and therefore could accumulate more contamination through small tears.

## A.6 Performance criteria

The authors of standards citing this standard should determine from their own risk analysis the performance criteria to be specified in their product standard. Some standards may be based on long tears of 40 mm, whilst others will require short tears of 10 mm or less. Some standards will require impact energies that represent average impacts for the use and type of the PPE, whereas others will require energies in excess of foreseeable impacts, because the potential for harm is so great.

## A.7 Specification of performance levels

For most types of PPE it is recommended that the following four Performance Levels will provide an adequate grading of materials. It will be noted that the levels in Table A.1 are based on a 40 mm maximum tear length, and also that the tear length roughly doubles for a doubling of the falling block mass. Thus this data can be also be used as the basis of performance criteria requiring different maximum tear lengths. The performance of representative materials should always be determined during drafting of a product standard.

**Level 4** (2000 g and 40 mm). Materials that do not tear more than 40 mm in this test are very unlikely to show propagating tears in any accident situation. Three of the materials included in table A1 have been used in a 112 km.h<sup>-1</sup> simulated motorcycle accident. Numerous test specimens were used and no tears occurred.

**Level 3** (1000 g and 40 mm). Materials reaching this level may be regarded as "strong". Under most operational conditions they will not tear even if caught on a protruding nail. Experience shows that when new the materials rarely fail through snagging and tearing. This level contains materials for clothing for arduous and hazardous industrial and leisure use.

**Level 2** (500 g and 40 mm). Materials reaching this level include those regarded as robust outdoor fabrics for the leisure market. Their snagging resistance is not high. They would not be strong enough for use in rough physical situations with dangerous chemicals, but could be adequate under good conditions with the same chemicals.

**Level 1** (250 g and 40 mm). Materials reaching this level only have minimal resistance to snagging and tearing. They are not suitable for use in any hazardous situation, or where the integrity of the garment is significant. Lining materials and wind permeable meshes will normally be in Level 1.

**Materials that fail to reach Level 1.** These materials are very weak in the face of puncturing and tearing hazards. They could be used to form specific weak links.

## A.8 Special conditions and deviation from the method in this European Standard

When this standard is cited in some circumstances it may be necessary to specify special conditions for the test or its application.

### A.8.1 Area of hole or tear length

If it is more important for the product performance specification to be based on the area of holes formed in snagging and tearing accidents rather than the tear length, the following method is proposed.

A cone of a suitable smooth hard material such as a metal or plastic should be marked with a series of circumferential lines at one millimetre intervals from 40 mm to 120 mm circumference. If the cone has a shallow taper these lines will be well spaced out. The test specimen after puncturing and tearing is removed from the apparatus and slid onto the cone. It should be gently slid down the cone until the entire perimeter of the hole is in contact with the cone and is at the same height. The perimeter length of the hole is then read off to the nearest 0,5 mm. It is suggested that the pass/fail level should normally be twice that of the tear length or 80 mm. For some end uses it will be desirable to specify much smaller holes. This should be done in the product standard on the basis of the risk analysis.

### **A.8.2 Pre-conditioning**

Some PPE is exposed to conditions of use that seriously and progressively weakens it. Sunlight, moisture, oils, bacteria, chemicals and air can all cause a loss of tear strength that could endanger users. Product standards should include preconditioning or ageing processes that allow prediction of the likely effects of storage and normal use.

### **A.8.3 Special test conditions**

Some PPE is exposed to conditions of use that seriously immediately weaken it. Water, oils, solvents, and high or low temperatures can all cause a loss of tear strength. Product standards should specify the testing of materials that are wet and after soaking, or at non-standard temperatures, or under other specific conditions, if the loss of tear strength could endanger users.

**Table A1 - Tear lengths of various materials tested by this European Standard in millimetres**

Material and performance level reached.	Direction of tear relative to the long axis of the roll	Mass of falling block, g			
		250	500	1000	2000
<b>Level 4</b>					<b>Pass</b>
290 g.m <sup>-2</sup> Monofilament plain weave para-aramid fabric	Along			11	14
	Across			8	9
	45°			10	13
600 g.m <sup>-2</sup> Long staple terry loop knitted para-aramid fabric	Along			16	22
	Across			7	21
	45°			18	23
1,5 mm thick cowhide (motorcycle racing leathers)	Not known			14	23
				16	29
				13	30
300 g.m <sup>-2</sup> Monofilament plain weave poly-amide fabric	Along			23	41
	Across			23	43
	45°			23	32
<b>Level 3</b>				<b>Pass</b>	<b>Fail</b>
400 g.m <sup>-2</sup> Warp knit mesh polyester fabric	Along			23	43
	Across			32	48
	45°			30	48
1,3 mm thick cowhide (street use motorcycle leathers)	Not known			33	37
				36	39
				19	55
480 g.m <sup>-2</sup> Polyurethane coated plain weave monofilament polyester fabric (coating 230 g.m <sup>-2</sup> )	Along			37	80
	Across			33	67
	45°			22	39
240 g.m <sup>-2</sup> para-aramid / meta-aramid 60/40% ripstop fabric	Along			40	93
	Across			29	64
	45°			33	53

Table A1: continued

Material and performance level reached.	Direction of tear relative to the roll	Mass of falling block, g			
		250	500	1000	2000
<b>Level 2</b>			<b>Pass</b>	<b>Fail</b>	<b>Fail</b>
1,2 mm thick cowhide rejected for motorcyclists leathers	Along hide	20	36		
	Across	18	57		
	45°	22	33		
250 g.m <sup>-2</sup> soft polyurethane coated knitted polyamide, high visibility waterproof fabric	Along		15	50	58*
	Across		27	85	140
	45°		20	43	90
230 g.m <sup>-2</sup> para-aramid/ meta aramid 23/77%, twill weave fabric	Along		22	56	110
	Across		22	57	116
	45°		23	52	86
200 g.m <sup>-2</sup> hard polyurethane coated staple polyamide plain weave fabric (coating 60 g.m <sup>-2</sup> ).	Along		28	60	
	Across		29	65	
	45°		23	38	
550 g.m <sup>-2</sup> cotton canvas	Along		37	90	
	Across		30	70	
	45°		19	37	
0,35 mm thick unsupported nitrile membrane (work glove)	Along	20	30		
	Across	18	38		
	45°	20	42		
<b>Level 1</b>		<b>Pass</b>	<b>Fail</b>	<b>Fail</b>	<b>Fail</b>
260 g.m <sup>-2</sup> Viscose/ meta-aramid 50/50% twill weave fabric	Along	32	44	101	
	Across	22	29	78	
	45°	18	23	44	

Table A,1: continued

150 g.m <sup>-2</sup> Simplex knit polyamide mesh lining fabric	Along	27	40		
	Across	25	36		
	45°	30	44		
130 g.m <sup>-2</sup> Warp knit high visibility polyester mesh	Along	33	62		
	Across	26	41		
	45°	26	34		
0,7 mm Cowhide. Weak boot lining grade leather	Along	31	60		
	Across	39	49		
	45°	20	48		
100 g.m <sup>-2</sup> plain weave polyester high visibility fabric, uncoated - see also below	Along	36			
	Across	39			
	45°	30			
<b>Fail</b>		<b>Fail</b>			
100 g.m <sup>-2</sup> polyurethane coated plain weave polyester high visibility fabric as above	Along	82			
	Across	70			
	45°	42			
* Tear reached edge of test specimen.					

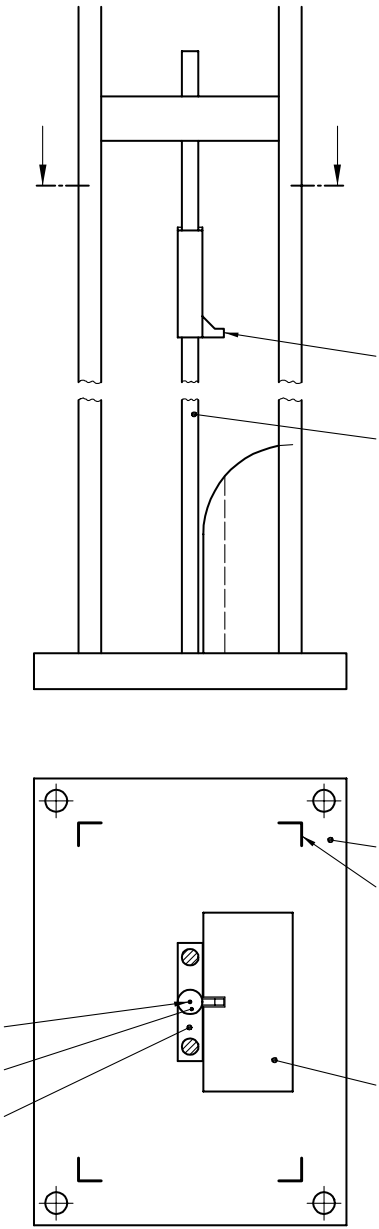

**Key**

- 1 A heavy rigid base
- 2 A supporting framework
- 3 Polished steel guide rod
- 4 Adjustable suspension for the electromagnet
- 5 An electromagnet
- 6 Falling mass - blade holding block
- 7 The tearing blade
- 8 Test specimen mounting block

**Figure 1 - A front view outline of an apparatus meeting the requirements of this European Standard**



**Key**

a = enlarged

- 1 Guidance rod
- 2 Guide tube
- 3 Blade holding block
- 4 Electromagnet contact plate
- 5 Tearing blade
- 6 Ground end of the tearing blade
- 7 Lower half-round edge of the tearing blade

$b_1$  Depth of the blade holding block,  $(27,5 \pm 2,5)$  mm

$b_2$  Distance of the end of the tearing blade from the centre of the block,  $(37,5 \pm 2,5)$  mm

$b_3$  Length of parallel sided part of the tearing blade,  $> 10$  mm

$d_1$  Diameter of the guidance rods,  $> 15$  mm

$h_1$  Height of blade holding block,  $(120 \pm 10)$  mm

$h_2$  Height of parallel sided part of the tearing blade,  $(10 \pm 0,1)$  mm

$l_1$  Guidance rod separation,  $(100 \pm 2)$  mm

$r_1$  Radius of the lower edges of tearing blade,  $(1,5 \pm 0,1)$  mm

$r_2$  Radius of the ground vertical edges of tearing blade,  $(0,2 \pm 0,1)$  mm

$t_1$  Clearance between the sliders or tube and the guidance rods,  $(1 \pm 0,5)$  mm

$t_2$  Blade width,  $(3 \pm 0,05)$  mm

$\alpha$  Ground angles on the tearing blade end,  $(60 \pm 3)^\circ$

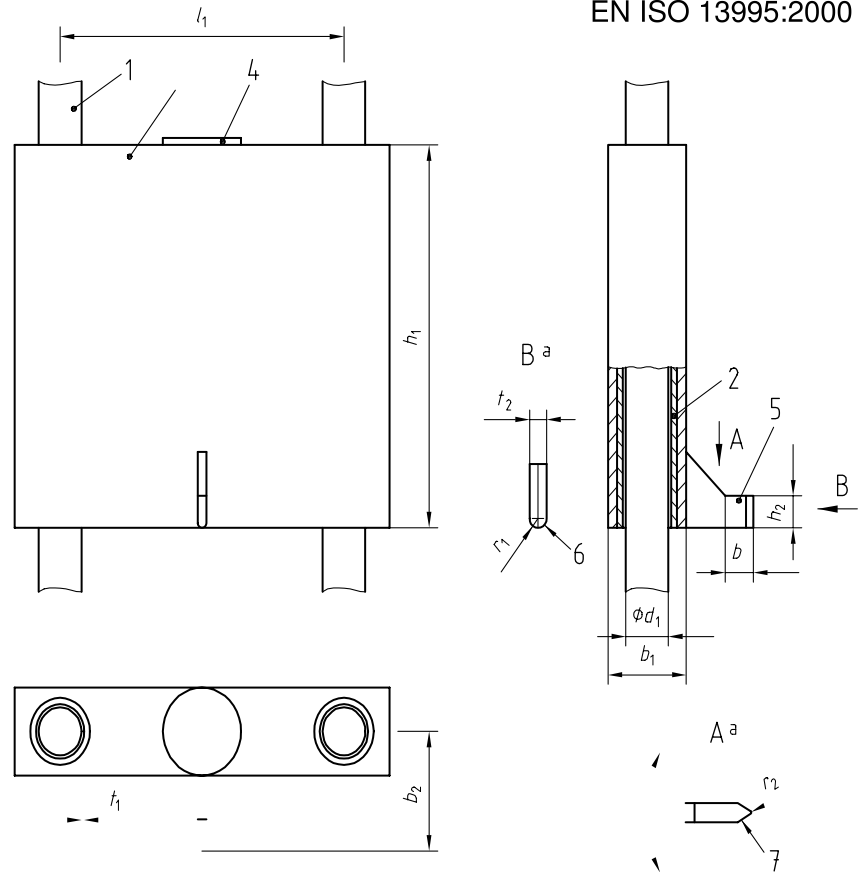

**Figure 2 - Blade holding block**

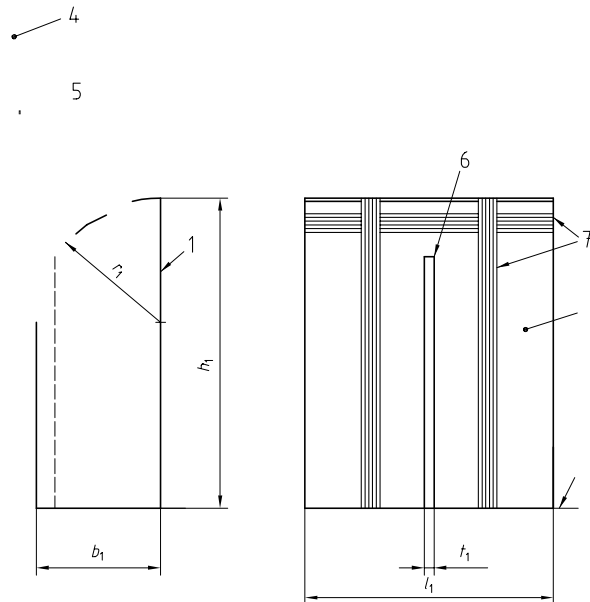

### Key

1 Back face of test specimen mounting block

2 Front face of test specimen mounting block

3 Base of apparatus

4 Guidance rod

5 Blade holding block

6 Machined slot

7 The positions of five parallel grooves machined into the block face to accept the ridges of the clamps as explained in 4.7.2

$b_1$  Depth of the block > 100 mm

$b_2$  Depth of the slot in the block,  $(15 \pm 1)$  mm

$b_3$  Length of the tearing blade entering the slot,  $(10 \pm 0,5)$  mm

$b_4$  Distance from the plane of the centres of the guidance rods to the front of the block,  $(27,5 \pm 2,5)$  mm

$h_1$  Height of the block,  $(250 \pm 10)$  mm

$l_1$  Width of the block, > 200 mm

$r_1$  Radius of the top of the test specimen mounting block,  $(100 \pm 1)$  mm

$t_1$  Width of the slot,  $(8 \pm 0,5)$  mm

**Figure 3 - The test specimen mounting block and its relation to the guidance rods and blade holding block**

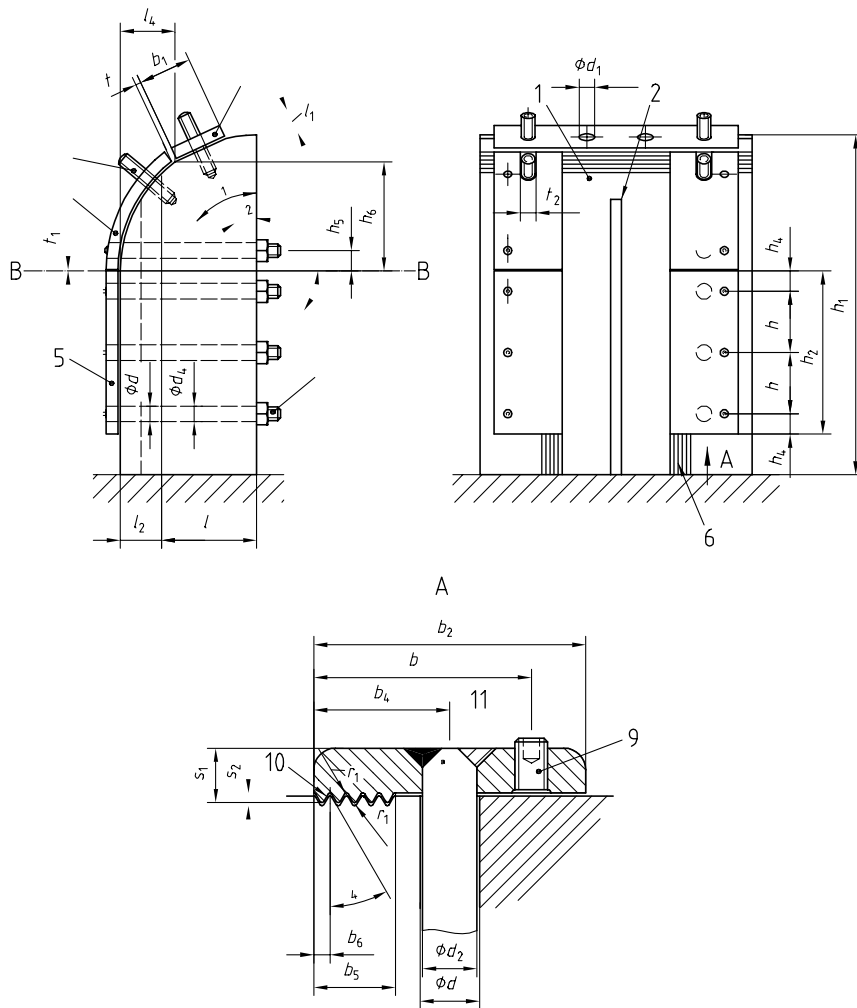

### Key

a = enlarged

- 1 Test specimen mounting block
- 2 Slot in mounting block
- 3 Horizontal top clamp
- 4 Vertical curved clamp
- 5 Vertical straight clamp
- 6 Grooves in mounting block face
- 7 Studs (M10)
- 8 Bolts through (M10)
- 9 Set screws (M6)
- 10 Ridges on clamp face
- 11 Welded in head of bolt through

A View to a vertical clamp (Detail of the ridge and groove tooth form)

B-B Plane of the junction between the straight vertical part of the test specimen mounting block and the quadrant upper section

$b_1$  Width of the horizontal clamp,  $(50 \pm 1)$  mm

$b_2$  Width of the vertical clamp,  $(50 \pm 1)$  mm.

$b_3$	Distance of the set screws from the edge of the clamp, $(40 \pm 2)$ mm
$b_4$	Distance of centre of bolt to the edge of the clamp $(25 \pm 1)$ mm
$b_5$	Width of the ridged and grooved sections of the block and clamp, $(15 \pm 0,25)$ mm
$b_6$	Pitch of the grooves and ridges, $(3 \pm 0,05)$ mm
$d_1$	Diameter of the clearance holes for the studs for the horizontal clamp, $(11,5 \pm 0,5)$ mm
$d_2$	Shank of M10 bolt, 10 mm
$d_3$	Sliding fit of M10 bolt in test specimen mounting block, 10,5 mm
$d_4$	Clearance fit on M10 bolt over the length $l_3$ , $(11,5 \pm 0,5)$ mm
$h_1$	Height of the test specimen mounting block, $(250 \pm 10)$ mm
$h_2$	Height of the straight vertical clamp, $(120 \pm 5)$ mm
$h_3$	Spacing between the through bolts, $(45 \pm 5)$ mm
$h_4$	Distance of the upper bolt to the clamp top edge, $(15 \pm 3)$ mm
$h_5$	Distance of the lower bolt to the clamp bottom edge, $(15 \pm 3)$ mm
$h_6$	Distance from the plane "B-B", $(80 \pm 1)$ mm
$l_1$	Stud insertion into the test specimen mounting block, $>19$ mm
$l_2$	Length of the hole with sliding fit, $(30 \pm 3)$ mm
$l_3$	Length of the hole with clearance, block depth - $l_2$
$l_4$	Distance from the front of the block $(40 \pm 1)$ mm
$l_4$ and $h_{6+}$	Dimensions locating the lower edge of the grooved section of the test specimen mounting block and the lower edge of the horizontal clamp
$r_1$	Radius of the groove bottoms and the ridge tips, $(0,4 \pm 0,05)$ mm
$s_1$	Thickness of the clamp to the ridge tips, $(10 \pm 0,5)$ mm
$s_2$	Clearance of the ridge tips in grooves, $(1,45 \pm 0,1)$ mm
$t_1$	Clearance between the straight and curved vertical clamps $(1 \pm 0,5)$ mm
$t_2$	The width of the slot for the stud on the curved clamp, $(11,5 \pm 0,5)$ mm
$t_3$	Clearance between the horizontal clamp and the vertical curved clamp when no test specimen is present, $(4 \pm 2)$ mm
$\alpha_1$	The angle determining the angle of the studs for the curved vertical clamps $(50 \pm 2)^\circ$
$\alpha_2$	The angle determining the angle of the studs for the horizontal clamp, $(25 \pm 1)^\circ$
$\alpha_3$	The angle determining the position of the lower edge of the horizontal clamp and the orientation of the studs. The line intersects the horizontal plane (B-B) of the junction between the straight vertical part of the test specimen mounting block and the quadrant upper section 100 mm from the front of the block, $(50 \pm 1)^\circ$
$\alpha_4$	The angles of the ridges and grooves to lines normal to the clamp and the block surfaces, $(30 \pm 3)^\circ$

**Figure 4 - The test specimen clamping system**

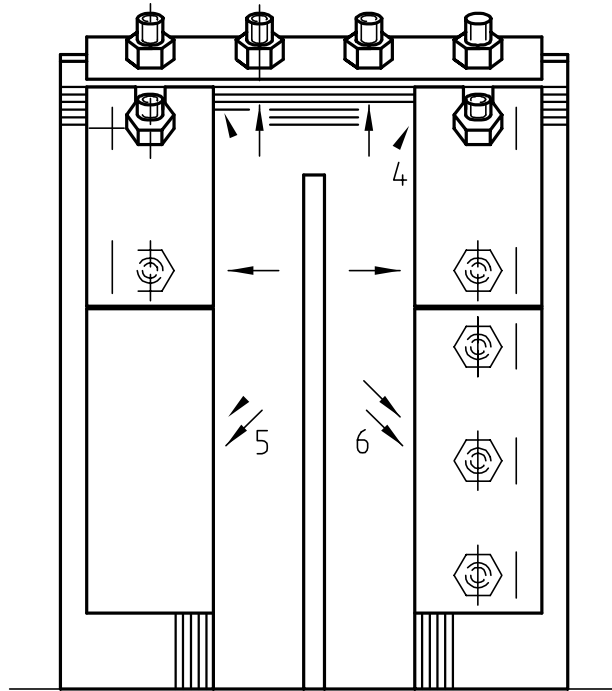

The figure shows the front face of the test specimen mounting block.

**Key**

1 to 14 The order in which the nuts on the studs and bolts should be tightened.

**Figure 5 - Order for tightening the bolts on the clamps**

The arrows indicate the directions in which the test specimen should be pressed by the fingers while tightening the bolt with the number indicated. The double arrows 5 and 6 indicate firmer pressure should be applied at these points to ensure even flattening of the specimen.

## Annex ZA (informative)

### Clauses of this European Standard addressing essential requirements or other provisions of EU Directives

This European Standard has been prepared under a mandate given to CEN by the European Commission and the European Trade Association and Supports essential requirements of EU Directive 89/686/EEC.

**WARNING:** Other requirements and other EU Directives may be applicable to the product(s) falling within the scope of this European Standard.

The following clauses of this European Standard are likely to support requirements of Directive 89/686/EEC, Annex II.

Compliance with the clauses of this European Standard provides one means of conforming with the specific essential requirements of the Directive concerned and associated EFTA regulations.

**Table ZA.1 – Correspondance between this European Standard and the EU Directive**

EU Directive 89/686/EEC, Annex II	Clauses of this European Standard
1 All risks encountered	1, Annex A
1.1.2.1 Highest level of protection possible	Annex A
1.1.2.2 Classes of protection appropriate to different levels of risk	Annex A
2.4 PPE subject to ageing	Annex A
3.3 Protection against physical injury (abrasion, perforation, cuts, bites)	1, Annex A
3.10 Protection against dangerous substances and infective agents	1, Annex A
3.10.2 Protection against cutaneous and ocular contact	1, Annex A



---

## BSI — British Standards Institution

BSI is the independent national body responsible for preparing British Standards. It presents the UK view on standards in Europe and at the international level. It is incorporated by Royal Charter.

### Revisions

British Standards are updated by amendment or revision. Users of British Standards should make sure that they possess the latest amendments or editions.

It is the constant aim of BSI to improve the quality of our products and services. We would be grateful if anyone finding an inaccuracy or ambiguity while using this British Standard would inform the Secretary of the technical committee responsible, the identity of which can be found on the inside front cover. Tel: 020 8996 9000. Fax: 020 8996 7400.

BSI offers members an individual updating service called PLUS which ensures that subscribers automatically receive the latest editions of standards.

### Buying standards

Orders for all BSI, international and foreign standards publications should be addressed to Customer Services. Tel: 020 8996 9001. Fax: 020 8996 7001. Standards are also available from the BSI website at <http://www.bsi-global.com>.

In response to orders for international standards, it is BSI policy to supply the BSI implementation of those that have been published as British Standards, unless otherwise requested.

### Information on standards

BSI provides a wide range of information on national, European and international standards through its Library and its Technical Help to Exporters Service. Various BSI electronic information services are also available which give details on all its products and services. Contact the Information Centre. Tel: 020 8996 7111. Fax: 020 8996 7048.

Subscribing members of BSI are kept up to date with standards developments and receive substantial discounts on the purchase price of standards. For details of these and other benefits contact Membership Administration. Tel: 020 8996 7002. Fax: 020 8996 7001. Further information about BSI is available on the BSI website at <http://www.bsi-global.com>.

### Copyright

Copyright subsists in all BSI publications. BSI also holds the copyright, in the UK, of the publications of the international standardization bodies. Except as permitted under the Copyright, Designs and Patents Act 1988 no extract may be reproduced, stored in a retrieval system or transmitted in any form or by any means – electronic, photocopying, recording or otherwise – without prior written permission from BSI.

This does not preclude the free use, in the course of implementing the standard, of necessary details such as symbols, and size, type or grade designations. If these details are to be used for any other purpose than implementation then the prior written permission of BSI must be obtained.

If permission is granted, the terms may include royalty payments or a licensing agreement. Details and advice can be obtained from the Copyright Manager. Tel: 020 8996 7070.