

**Vitreous and porcelain
enamels —
Determination of crack
formation temperature
in the thermal shock
testing of enamels for
the chemical industry**

ICS 25.220.50

National foreword

This British Standard is the UK implementation of EN ISO 13807:2009. It is identical with ISO 13807:1999, incorporating technical corrigendum October 2000. It supersedes BS ISO 13807:1999 which is withdrawn.

The UK participation in its preparation was entrusted to Technical Committee STI/36, Vitreous enamel coatings.

A list of organizations represented on this committee can be obtained on request to its secretary.

This publication does not purport to include all the necessary provisions of a contract. Users are responsible for its correct application.

Compliance with a British Standard cannot confer immunity from legal obligations.

This British Standard was published under the authority of the Standards Committee and comes into effect on 15 February 2001

Amendments/corrigenda issued since publication

Amd. No.	Date	Comments
13024 Technical Corrigendum	July 2001	Implementation of ISO corrigendum October 2000. In 7.1 the last sentence in the paragraph after Figure 1 has been replaced
	30 June 2009	This corrigendum renumbers BS ISO 13807:1999 as BS EN ISO 13807:2009

English Version

Vitreous and porcelain enamels - Determination of crack formation temperature in the thermal shock testing of enamels for the chemical industry (ISO 13807:1999, including Cor 1:2000)

Émaux vitrifiés - Détermination de la température de fissuration par choc thermique d'émaux pour l'industrie chimique (ISO 13807:1999, Cor 1:2000 inclus)

Aluminium-Emails - Bestimmung der Rissbildungstemperatur von Chemie-Emails beim Abschreckversuch (ISO 13807:1999, einschließlich Cor 1:2000)

This European Standard was approved by CEN on 13 December 2008.

CEN members are bound to comply with the CEN/CENELEC Internal Regulations which stipulate the conditions for giving this European Standard the status of a national standard without any alteration. Up-to-date lists and bibliographical references concerning such national standards may be obtained on application to the CEN Management Centre or to any CEN member.

This European Standard exists in three official versions (English, French, German). A version in any other language made by translation under the responsibility of a CEN member into its own language and notified to the CEN Management Centre has the same status as the official versions.

CEN members are the national standards bodies of Austria, Belgium, Bulgaria, Cyprus, Czech Republic, Denmark, Estonia, Finland, France, Germany, Greece, Hungary, Iceland, Ireland, Italy, Latvia, Lithuania, Luxembourg, Malta, Netherlands, Norway, Poland, Portugal, Romania, Slovakia, Slovenia, Spain, Sweden, Switzerland and United Kingdom.



EUROPEAN COMMITTEE FOR STANDARDIZATION
COMITÉ EUROPÉEN DE NORMALISATION
EUROPÄISCHES KOMITEE FÜR NORMUNG

Management Centre: Avenue Marnix 17, B-1000 Brussels

Foreword

The text of ISO 13807:1999, including Cor 1:2000 has been prepared by Technical Committee ISO/TC 107 “Metallic and other inorganic coatings” of the International Organization for Standardization (ISO) and has been taken over as EN ISO 13807:2009 by Technical Committee CEN/TC 262 “Metallic and other inorganic coatings” the secretariat of which is held by BSI.

This European Standard shall be given the status of a national standard, either by publication of an identical text or by endorsement, at the latest by July 2009, and conflicting national standards shall be withdrawn at the latest by July 2009.

Attention is drawn to the possibility that some of the elements of this document may be the subject of patent rights. CEN [and/or CENELEC] shall not be held responsible for identifying any or all such patent rights.

According to the CEN/CENELEC Internal Regulations, the national standards organizations of the following countries are bound to implement this European Standard: Austria, Belgium, Bulgaria, Cyprus, Czech Republic, Denmark, Estonia, Finland, France, Germany, Greece, Hungary, Iceland, Ireland, Italy, Latvia, Lithuania, Luxembourg, Malta, Netherlands, Norway, Poland, Portugal, Romania, Slovakia, Slovenia, Spain, Sweden, Switzerland and the United Kingdom.

Endorsement notice

The text of ISO 13807:1999, including Cor 1:2000 has been approved by CEN as a EN ISO 13807:2009 without any modification.

Vitreous and porcelain enamels — Determination of crack formation temperature in the thermal shock testing of enamels for the chemical industry

1 Scope

This International Standard specifies a test method for the determination of the crack formation temperature of enamels for the chemical industry by subjecting enamelled steel specimens to thermal shock using cold water.

The value of the crack formation temperature measured according to this test method is not valid for the finished component (see annex A). It is a parameter of vitreous and porcelain enamels for comparing the relative quality of different enamel formulations.

2 Normative references

The following normative documents contain provisions which, through reference in this text, constitute provisions of this International Standard. For dated references, subsequent amendments to, or revisions of, any of these publications do not apply. However, parties to agreements based on this International Standard are encouraged to investigate the possibility of applying the most recent editions of the normative documents indicated below. For undated references, the latest edition of the normative document referred to applies. Members of ISO and IEC maintain registers of currently valid International Standards.

ISO 2746, *Vitreous and porcelain enamels — Enamelled articles for service under highly corrosive conditions — High voltage test.*

ISO 2808, *Paints and varnishes — Determination of film thickness.*

ISO 3819, *Laboratory glassware — Beakers.*

ISO 10141, *Vitreous and porcelain enamels — Vocabulary.*

3 Terms and definitions

For the purposes of this International Standard, the terms and definitions given in ISO 10141 as well as the following apply.

3.1

crack formation temperature

thermal shock temperature at which the first damage to the enamel occurs in the form of cracks and/or chipping

3.2

thermal shock temperature

temperature of the specimen immediately before quenching with cold water

4 Designation

The test method for the determination of the crack formation temperature of enamels for the chemical industry by the thermal shock test described in this International Standard is designated as follows:

Test ISO 13807

5 Principle

The specimen is heated to the thermal shock temperature in a drying oven. After reaching the thermal shock temperature, the enamelled surface is covered by water at a temperature between 10 °C and 30 °C. Then the specimen is dried and visually examined for damage. To make cracks visible, the entire enamel surface is sprayed with electrostatically charged talcum powder. If no damage to the enamel is found after the first thermal shock test, the test shall be repeated at a thermal shock temperature 10 °C higher than in the previous test.

6 Apparatus

- 6.1 **Drying oven**, capable of maintaining temperatures of at least 300 °C.
- 6.2 **Low-form beaker**, having a capacity of 2 000 ml meeting the requirements of ISO 3819.
- 6.3 **Spray gun**, equipped with a hard-rubber nozzle for electrostatically charging the talcum powder.

7 Specimens

7.1 Shape and preparation of specimens

Specimens shall be square sheet metal plates with a thickness of at least 10 mm and an edge length of 150 mm that have been enamelled on one side.

Alternatively, specimens as shown in Figure 1 made of 10MnTi3 low-alloyed enamelling structural steel may be used. The steel shall have the following nominal composition (% mass fraction):

- carbon, $\leq 0,12$ %;
- manganese, 0,40 % to 1,00 %;
- titanium 0,10 % to 0,16 %;
- phosphorus $\leq 0,035$ %;
- sulphur, $\leq 0,030$ %.

During the enamelling process, these specimens shall be held in the horizontal position by means of a rod inserted in the 5 mm hole. The ground coat shall cover the entire surface. The cover coat may be applied only to the top and convex surface (radius 8 mm).

NOTE Besides the determination of crack formation temperature, enamelled specimens shown in Figure 1 may also be used for corrosion tests in closed systems according to ISO 13806.

Dimensions in millimetres
Roughness values in micrometres

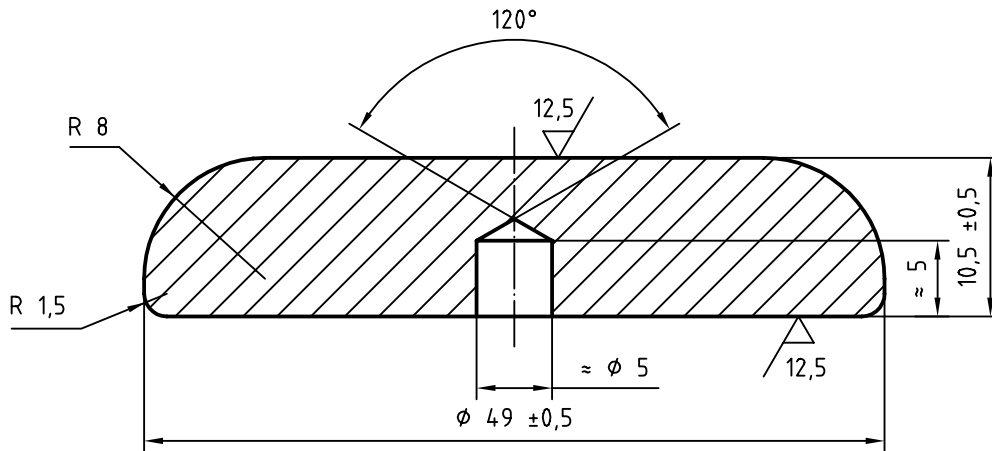

Figure 1 — Steel specimen for determination of the crack formation temperature of enamels by thermal shock

Prepare the specimens by the same enamelling process used for the enamelled product, including the pretreatment, type of ground and cover coat, application technique, firing temperature and thickness of the ground coat. After each firing step, the specimens are removed from the oven and may be cooled in air. However, the specimens shall be submitted to controlled cooling after the last coating or directly after the last firing. Heat the specimens up to 600 °C in an oven, maintain this temperature for at least 20 min, then cool to ≤ 250 °C at a cooling rate of ≤ 1 °C/min (see annex A).

The overall thickness of the enamel measured by the method given in ISO 2808 shall be between 0,8 mm and 1,4 mm.

The finished enamel coating shall be free from defects. This shall be checked visually, as well as with the high voltage test at 12 kV described in ISO 2746.

Specimens of other shapes or manufacture may be used, when specified by the purchaser. The use of specimens having different shapes or manufacture shall be noted in the test report.

7.2 Number of specimens

Two specimens of the same type shall be used for each determination.

8 Procedure

8.1 Place the two enamelled specimens with the enamelled surface upwards in the drying oven (6.1) heated to the thermal shock temperature. The thermal shock temperature shall be about 20 °C below the expected crack formation temperature. If necessary, determine the crack formation temperature by a preliminary test.

8.2 Determine by a preliminary test, the time span necessary for heating the specimens to the thermal shock temperature. After the specimens have reached the thermal shock temperature, open the drying oven (6.1) and remove one specimen by means of a fork or other tool, without touching the enamel surface. Hold the specimen horizontally and cover the centre of it by pouring 2 l of water at a temperature between 10 °C and 30 °C, pouring the water at a rate of approximately 100 ml/s. From the moment the drying oven (6.1) is opened until the cold water is poured on to the specimen, no more than 3 s shall elapse.

8.3 After the first specimen has been removed from the drying oven (6.1), leave the second specimen in the oven until it has again reached the thermal shock temperature, plus an additional 5 min. Then repeat the thermal shock step with the second specimen, by the procedure described in 8.2.

8.4 Check the dried specimens visually for damage to the enamel. To make cracks easier to detect, spray the enamel with electrostatically charged talcum powder using the spray gun (6.3). This technique will make even fine cracks easy to detect.

8.5 If no damage to the enamel is detected on one or both specimens after the thermal shock test, repeat the test on the same specimens at a thermal shock temperature that is 10 °C higher than in the first test.

8.6 If the difference in the crack formation temperature as determined by the above procedure is greater than 10 °C, the test shall be repeated with two new specimens.

9 Expression of results

Average the crack formation temperatures that do not differ by more than 10 °C.

10 Test report

The test report shall include the following information:

- a) the type of enamel tested;
- b) the designation (see clause 4) of this test method, i.e. Test ISO 13807;
- c) the thickness of the enamel coating;
- d) the material code or designation of the basis metal;
- e) if applicable, the shape of the specimen, if specified by the purchaser (see clause 7);
- f) the description of the damage to the enamel coating;
- g) the individual values of the crack formation temperatures, in °C;
- h) the arithmetic mean of the crack formation temperature, in °C.

Annex A (informative)

Explanatory notes

In the case of vitreous enamelling, the two components, enamel and metal, are firmly fused together by means of a mechanical and chemical bond. As a result of the different thermal expansion and softening characteristics of enamel and metal, temperature-dependent stresses develop in the composite. The components of the composite are generally designed such that compressive stresses are present in the melted-on enamel coating.

In the case of vitreous enamelling, four different types of thermal shock are known:

- a) cold-shock on the enamel side;
- b) heat shock on the metal side;
- c) heat shock on the enamel side;
- d) cold shock on the metal side.

Since cold shock on the enamel side with cold water is the most critical type, this test is specified in this International Standard.

The crack formation temperature of enamel as determined by thermal shock testing is a characteristic of the composite material. No conclusions should be drawn from the results of this thermal shock test about the resistance to cold of an enamelled product. In practice, the crack formation temperature is influenced by stresses due to manufacture, that originate from welded joints or from non-uniform cooling from the enamelling temperature. The crack formation temperature is also influenced by mechanical deformation occurring after enamelling as a result of welding on the double jacket of the vessel or by support forces introduced by the container support structure. In addition, stresses during service that occur at a particular production stage, e.g., compressive stress on the inner vessel or jacket, may affect the crack formation temperature. Consequently, the thermal shock resistance guaranteed by the enamel manufacturer for the enamelled product will always be considerably lower than the crack formation temperature determined in accordance with this International Standard.

The controlled cooling of specimens after enamelling (see 7.1) reduces the stresses that are created by uncontrolled cooling in air. If cooling is controlled, the measured crack formation temperatures of different enamels can be compared.

Specimens coated with the identical enamel that are rapidly cooled in air without controlling the rate of cooling display crack formation temperatures that are about 10 °C to 30 °C higher due to the stresses caused by rapid cooling. The stress-free state of a specimen cannot be recognized visually, but can be generated experimentally by slow cooling from 600 °C (see 7.1) before measuring the crack formation temperature.

Repeating a thermal shock test at the same thermal shock temperature has no influence or only a very slight influence (less than 5 °C) on the crack formation temperature. Therefore, a repetition of the thermal shock test at the same temperature is not provided in this International Standard.

Bibliography

- [1] ISO 13806, *Vitreous and porcelain enamels — Corrosion tests in closed systems*.

British Standards Institution (BSI)

BSI is the independent national body responsible for preparing British Standards. It presents the UK view on standards in Europe and at the international level. It is incorporated by Royal Charter.

Revisions

British Standards are updated by amendment or revision. Users of British Standards should make sure that they possess the latest amendments or editions.

It is the constant aim of BSI to improve the quality of our products and services. We would be grateful if anyone finding an inaccuracy or ambiguity while using this British Standard would inform the Secretary of the technical committee responsible, the identity of which can be found on the inside front cover.
Tel: +44 (0)20 8996 9000 Fax: +44 (0)20 8996 7400

BSI offers members an individual updating service called PLUS which ensures that subscribers automatically receive the latest editions of standards.

Buying standards

Orders for all BSI, international and foreign standards publications should be addressed to Customer Services.

Tel: +44 (0)20 8996 9001 Fax: +44 (0)20 8996 7001

Email: orders@bsigroup.com

You may also buy directly using a debit/credit card from the BSI Shop on the Website <http://www.bsigroup.com/shop>.

In response to orders for international standards, it is BSI policy to supply the BSI implementation of those that have been published as British Standards, unless otherwise requested.

Information on standards

BSI provides a wide range of information on national, European and international standards through its Library and its Technical Help to Exporters Service. Various BSI electronic information services are also available which give details on all its products and services. Contact the Information Centre.

Tel: +44 (0)20 8996 7111 Fax: +44 (0)20 8996 7048

Email: info@bsigroup.com

Subscribing members of BSI are kept up to date with standards developments and receive substantial discounts on the purchase price of standards. For details of these and other benefits contact Membership Administration.

Tel: +44 (0)20 8996 7002 Fax: +44 (0)20 8996 7001

Email: membership@bsigroup.com

Information regarding online access to British Standards via British Standards Online can be found at <http://www.bsigroup.com/BSOL>.

Further information about BSI is available on the BSI website at <http://www.bsigroup.com>.

Copyright

Copyright subsists in all BSI publications. BSI also holds the copyright, in the UK, of the publications of the international standardization bodies. Except as permitted under the Copyright, Designs and Patents Act 1988 no extract may be reproduced, stored in a retrieval system or transmitted in any form or by any means – electronic, photocopying, recording or otherwise – without prior written permission from BSI.

This does not preclude the free use, in the course of implementing the standard, of necessary details such as symbols, and size, type or grade designations. If these details are to be used for any other purpose than implementation then the prior written permission of BSI must be obtained.

Details and advice can be obtained from the Copyright & Licensing Manager.

Tel: +44 (0)20 8996 7070 Email: copyright@bsigroup.com