

BS EN ISO 13792:2012



BSI Standards Publication

**Thermal performance of  
buildings — Calculation of  
internal temperatures of a  
room in summer without  
mechanical cooling —  
Simplified methods**

**bsi.**

...making excellence a habit.™

**National foreword**

This British Standard is the UK implementation of EN ISO 13792:2012. It supersedes BS EN ISO 13792:2005, which is withdrawn.

The UK participation in its preparation was entrusted to Technical Committee B/540/8, Mirror committee for ISO/TC 163 - Thermal Performance and Energy use in the built Environment.

A list of organizations represented on this committee can be obtained on request to its secretary.

This publication does not purport to include all the necessary provisions of a contract. Users are responsible for its correct application.

© The British Standards Institution 2012  
Published by BSI Standards Limited 2012

ISBN 978 0 580 67534 8

ICS 91.120.10

**Compliance with a British Standard cannot confer immunity from legal obligations.**

This British Standard was published under the authority of the Standards Policy and Strategy Committee on 30 April 2012.

**Amendments issued since publication**

Date	Text affected
------	---------------

---

English Version

**Thermal performance of buildings - Calculation of internal  
temperatures of a room in summer without mechanical cooling -  
Simplified methods (ISO 13792:2012)**

Performance thermique des bâtiments - Calcul des  
températures intérieures en été d'un local sans dispositif de  
refroidissement mécanique - Méthodes simplifiées (ISO  
13792:2012)

Wärmetechnisches Verhalten von Gebäuden - Berechnung  
von sommerlichen Raumtemperaturen bei Gebäuden ohne  
Anlagentechnik - Vereinfachtes Berechnungsverfahren  
(ISO 13792:2012)

This European Standard was approved by CEN on 14 March 2012.

CEN members are bound to comply with the CEN/CENELEC Internal Regulations which stipulate the conditions for giving this European Standard the status of a national standard without any alteration. Up-to-date lists and bibliographical references concerning such national standards may be obtained on application to the CEN-CENELEC Management Centre or to any CEN member.

This European Standard exists in three official versions (English, French, German). A version in any other language made by translation under the responsibility of a CEN member into its own language and notified to the CEN-CENELEC Management Centre has the same status as the official versions.

CEN members are the national standards bodies of Austria, Belgium, Bulgaria, Croatia, Cyprus, Czech Republic, Denmark, Estonia, Finland, France, Germany, Greece, Hungary, Iceland, Ireland, Italy, Latvia, Lithuania, Luxembourg, Malta, Netherlands, Norway, Poland, Portugal, Romania, Slovakia, Slovenia, Spain, Sweden, Switzerland, Turkey and United Kingdom.



EUROPEAN COMMITTEE FOR STANDARDIZATION  
COMITÉ EUROPÉEN DE NORMALISATION  
EUROPÄISCHES KOMITEE FÜR NORMUNG

**Management Centre: Avenue Marnix 17, B-1000 Brussels**

## Foreword

This document (EN ISO 13792:2012) has been prepared by Technical Committee ISO/TC 163 "Thermal performance and energy use in the built environment" in collaboration with Technical Committee CEN/TC 89 "Thermal performance of buildings and building components" the secretariat of which is held by SIS.

This European Standard shall be given the status of a national standard, either by publication of an identical text or by endorsement, at the latest by September 2012, and conflicting national standards shall be withdrawn at the latest by September 2012.

Attention is drawn to the possibility that some of the elements of this document may be the subject of patent rights. CEN [and/or CENELEC] shall not be held responsible for identifying any or all such patent rights.

This document supersedes EN ISO 13792:2005.

According to the CEN/CENELEC Internal Regulations, the national standards organizations of the following countries are bound to implement this European Standard: Austria, Belgium, Bulgaria, Croatia, Cyprus, Czech Republic, Denmark, Estonia, Finland, France, Germany, Greece, Hungary, Iceland, Ireland, Italy, Latvia, Lithuania, Luxembourg, Malta, Netherlands, Norway, Poland, Portugal, Romania, Slovakia, Slovenia, Spain, Sweden, Switzerland, Turkey and the United Kingdom.

### Endorsement notice

The text of ISO 13792:2012 has been approved by CEN as a EN ISO 13792:2012 without any modification.

# Contents

Page

Foreword .....	iv
Introduction.....	vi
<b>1 Scope .....</b>	<b>1</b>
<b>2 Normative references .....</b>	<b>1</b>
<b>3 Terms, definitions, symbols and units .....</b>	<b>2</b>
3.1 Terms and definitions .....	2
3.2 Symbols and units.....	2
3.3 Subscripts .....	5
<b>4 Input data and results .....</b>	<b>6</b>
4.1 Assumptions.....	6
4.2 Boundary conditions and input data.....	6
4.2.1 Boundary conditions.....	6
4.2.2 Heat transfer coefficients .....	7
4.2.3 Geometrical and thermophysical parameters of the room envelope .....	7
4.2.4 Air change rate .....	10
4.2.5 Internal gain .....	11
4.3 Output data .....	11
<b>5 Calculation procedure.....</b>	<b>11</b>
<b>6 Validation procedures.....</b>	<b>12</b>
6.1 Introduction.....	12
6.2 Validation procedure for the calculation method .....	12
6.2.1 General .....	12
6.2.2 Geometry .....	12
6.2.3 Description of elements.....	13
6.2.4 Combination of elements.....	14
6.2.5 Climatic data .....	15
6.2.6 Internal energy sources .....	16
6.2.7 Ventilation pattern .....	17
6.2.8 Test results .....	17
6.3 Validation procedure for the sunlit factor due to external obstructions .....	18
<b>Annex A (informative) Examples of solution model.....</b>	<b>21</b>
<b>Annex B (informative) Air changes for natural ventilation .....</b>	<b>37</b>
<b>Annex C (informative) Evaluation of shaded area of a plane surface due to external obstructions.....</b>	<b>39</b>
<b>Annex D (informative) Internal gains .....</b>	<b>42</b>
<b>Annex E (informative) Examples of calculation.....</b>	<b>44</b>
<b>Annex F (informative) Normative references to international publications with their corresponding European publications.....</b>	<b>53</b>

## Foreword

ISO (the International Organization for Standardization) is a worldwide federation of national standards bodies (ISO member bodies). The work of preparing International Standards is normally carried out through ISO technical committees. Each member body interested in a subject for which a technical committee has been established has the right to be represented on that committee. International organizations, governmental and non-governmental, in liaison with ISO, also take part in the work. ISO collaborates closely with the International Electrotechnical Commission (IEC) on all matters of electrotechnical standardization.

International Standards are drafted in accordance with the rules given in the ISO/IEC Directives, Part 2.

The main task of technical committees is to prepare International Standards. Draft International Standards adopted by the technical committees are circulated to the member bodies for voting. Publication as an International Standard requires approval by at least 75 % of the member bodies casting a vote.

Attention is drawn to the possibility that some of the elements of this document may be the subject of patent rights. ISO shall not be held responsible for identifying any or all such patent rights.

ISO 13792 was prepared by Technical Committee ISO/TC 163, *Thermal performance and energy use in the built environment*, Subcommittee SC 2, *Calculation methods*.

This second edition cancels and replaces the first edition (ISO 13792:2005), which has been technically revised. The main changes compared to the previous edition are given in the following table.

Clause/subclause	Changes
2	Added ISO 9050, ISO 10292, and ISO 15927-2
3.2 and 3.3	Deleted $g$ and $m$ Added subscript $sl$
4.2.1.2	Added first and second list items, descriptions of the reference
4.2.3	Replaced $U^*$ by $U$ Replaced $g$ by $S_f$ as the solar heat gain factor Deleted Equation (1) and replaced old Equations (2) to (6) by Equations (1) to (5) Amended Equations (2) to (4)
4.2.3.2	Third list item, replaced $g$ by $S_{f1}$
6.2.5	Added the descriptions of the latitudes in Tables 7, 8 and 9
A.2.1	Amended the descriptions of symbols $S_f$ and $n$
A.2.2	Amended Equation (A.1)
A.2.3	Added the equation to define $A_t$ Amended Equation (A.24)
A.3.1	Amended Equations (A.28), (A.31), (A.32), (A.33) and (A.34)
A.3.2.1	Amended Equation (A.35) Amended the unit for $c$
A.3.2.2.1	Amended Equations (A.38), (A.39), (A.40), (A.45) and (A.47) Changed the description of $H_T$
A.3.2.2.2	Amended Equation (A.49)
A.3.2.3	Amended Equation (A.52)
A.3.3	Amended Equation (A.53)
C.2	Added a title to Table C.1
E.1	Amended the description of $S_f$ in Table E.5
E.3	Replaced $U_m^*$ by $U_m$

## Introduction

Knowledge of the internal temperature of a room in warm periods is needed for several purposes, such as:

- a) defining the characteristics of a room at the design stage, in order to prevent or limit overheating in summer;
- b) assessing the need for a cooling installation.

The internal temperature is influenced by many parameters such as climatic data, envelope characteristics, ventilation and internal gains. The internal temperature of a room in warm periods can be determined using detailed calculation methods. ISO 13791 lays down the assumptions and the criteria to be satisfied for assessment of internal conditions in the summer with no mechanical cooling. However, for a number of applications, the calculation methods based on ISO 13791 are too detailed. Simplified methods are derived from more or less the same description of the heat transfer processes in a building. Each calculation method has its own simplification, assumptions, fixed values, special boundary conditions and validity area. A simplified method can be implemented in many ways. In general, the maximum allowed simplification of the calculation method and the input data is determined by the required amount and accuracy of the output data.

This International Standard defines the level, the amount and the accuracy of the output data and the allowed simplification of the input data.

No particular calculation methods are included in the normative part of this International Standard. As examples, two calculation methods are given in Annex A. They are based on the simplification of the heat transfer processes that guarantees the amount and the accuracy of the output data and the simplification of the input data required by this International Standard.

The use of these simplified calculation methods does not imply that other calculation methods are excluded from standardization, nor does it hamper future developments. Clause 6 gives the criteria to be satisfied in order for a method to comply with this International Standard.



# Thermal performance of buildings — Calculation of internal temperatures of a room in summer without mechanical cooling — Simplified methods

## 1 Scope

This International Standard specifies the required input data for simplified calculation methods for determining the maximum, average and minimum daily values of the operative temperature of a room in warm periods:

- a) to define the characteristics of a room at the design stage in order to avoid overheating in summer;
- b) to define whether the installation of a cooling system is necessary or not.

Clause 6 gives the criteria to be met by a calculation method in order to satisfy this International Standard.

## 2 Normative references

The following referenced documents are indispensable for the application of this document. For dated references, only the edition cited applies. For undated references, the latest edition of the referenced document (including any amendments) applies.

ISO 6946, *Building components and building elements — Thermal resistance and thermal transmittance — Calculation method*

ISO 7345, *Thermal insulation — Physical quantities and definitions*

ISO 9050, *Glass in building — Determination of light transmittance, solar direct transmittance, total solar energy transmittance, ultraviolet transmittance and related glazing factors*

ISO 10077-1, *Thermal performance of windows, doors and shutters — Calculation of thermal transmittance — Part 1: General*

ISO 10292, *Glass in building — Calculation of steady-state U values (thermal transmittance) of multiple glazing*

ISO 13370, *Thermal performance of buildings — Heat transfer via the ground — Calculation methods*

ISO 13791, *Thermal performance of buildings — Calculation of internal temperatures of a room in summer without mechanical cooling — General criteria and validation procedures*

ISO 15927-2, *Hygrothermal performance of buildings — Calculation and presentation of climatic data — Part 2: Hourly data for design cooling load*

EN 410, *Glass in building — Determination of luminous and solar characteristics of glazing*

EN 673, *Glass in building — Determination of thermal transmittance (U value) — Calculation method*

EN 13363-1, *Solar protection devices combined with glazing — Calculation of solar and light transmittance — Part 1: Simplified method*

### 3 Terms, definitions, symbols and units

#### 3.1 Terms and definitions

For the purposes of this document, the terms and definitions given in ISO 7345 and the following apply.

##### 3.1.1

###### **internal environment**

closed space delimited from the external environment or adjacent spaces by the building fabric

##### 3.1.2

###### **room element**

wall, ceiling, roof, floor, door or window that separates the internal environment from the external environment or an adjacent space

##### 3.1.3

###### **room air**

air in the room

##### 3.1.4

###### **internal air temperature**

temperature of the room air

##### 3.1.5

###### **internal surface temperature**

temperature of the internal surface of a building element

##### 3.1.6

###### **mean radiant temperature**

uniform surface temperature of an enclosure in which an occupant would exchange the same amount of radiant heat as in the actual non-uniform enclosure

##### 3.1.7

###### **operative temperature**

uniform temperature of an enclosure in which an occupant would exchange the same amount of heat by radiation plus convection as in the actual non-uniform environment

NOTE For simplification, the mean value of the air temperature and the mean radiant temperature of the room can be used.

#### 3.2 Symbols and units

For the purposes of this document, the following symbols and units apply.

Symbol	Definition	Unit
$A$	area	$m^2$
$A_c$	cavity area	$m^2$
$A_m$	thermal mass area	$m^2$
$A_s$	sunlit area	$m^2$
$A_t$	exposed area	$m^2$
$A_w$	wall area	$m^2$
$C$	heat capacity	J/K
$C_i$	internal heat capacity	J/K

$C_m$	heat capacity of the enclosure elements	J/K
$c$	specific heat capacity	J/(kg·K)
$c_a$	specific heat capacity of air at constant pressure	J/(kg·K)
$d$	thickness	m
$F_a$	decrement factor	—
$F_s$	surface factor	—
$F_{sm}$	surface factor of the envelope	—
$f_c$	correction factor for transmission thermal load	—
$f_{ex}$	exposure factor	—
$f_r$	correction factor for solar thermal load	—
$f_s$	sunlit factor	—
$f_{sa}$	solar-to-air factor	—
$f_{sl}$	solar loss factor	—
$f_t$	frame factor	—
$f_v$	ventilation factor	—
$H_{ei}$	heat transfer coefficient due to the air ventilation	W/K
$H_{em}$	conventional heat transfer coefficient between the external environment and the internal surface of the heavy components	W/K
$H_{es}$	global heat transfer coefficient between the internal and external environment	W/K
$H_{is}$	heat transfer coefficient due to internal exchanges by convection and radiation	W/K
$H_{ms}$	conventional internal heat transfer coefficient	W/K
$H_T$	heat transfer coefficient of the envelope	W/K
$h$	surface coefficient of heat transfer	W/(m <sup>2</sup> ·K)
$h_c$	convective heat transfer coefficient	W/(m <sup>2</sup> ·K)
$h_r$	radiative heat transfer coefficient	W/(m <sup>2</sup> ·K)
$I$	intensity of solar radiation	W/m <sup>2</sup>
$I_r$	reflected component of the solar radiation reaching the surface	W/m <sup>2</sup>
$l$	length	m
$N_c$	number of components facing the indoor environment	—
$N_e$	number of external components	—
$N_h$	number of heavy opaque components	—
$N_l$	number of light opaque components	—
$N_p$	number of opaque components	—
$N_s$	number of internal sources	—
$N_w$	number of glazing components	—
$n$	air changes per hour	1/h
$q$	density of heat flow rate	W/m <sup>2</sup>
$R$	thermal resistance	m <sup>2</sup> ·K/W

$R_{ei}$	thermal resistance due to air ventilation	$m^2 \cdot K/W$
$S_f$	solar heat gain factor	—
$S_{fc}$	solar heat gain factor for the closed cavity	—
$S_{f1}$	solar direct transmittance	—
$S_{f2}$	secondary heat transfer factor	—
$S_{f3}$	tertiary heat transfer factor	—
$S_{fv}$	solar heat gain factor for the ventilated cavity	—
$T$	thermodynamic temperature	K
$t$	time	s
$U$	thermal transmittance	$W/(m^2 \cdot K)$
$U_e$	thermal transmittance between the external environment and the air cavity	$W/(m^2 \cdot K)$
$U_i$	thermal transmittance between the internal environment and the air cavity	$W/(m^2 \cdot K)$
$U_w$	thermal transmittance of the glazing component	$W/(m^2 \cdot K)$
$V$	volume	$m^3$
$v$	velocity	m/s
$x_v$	vertical shaded distance	—
$Y$	admittance	$W/(m^2 \cdot K)$
$Y_T$	total admittance	$W/(m^2 \cdot K)$
$\alpha_{sr}$	solar absorptance	—
$\beta$	solar altitude angle	degrees
$\varepsilon$	long-wave emissivity of the surface	—
$\theta$	Celsius temperature	$^{\circ}C$
$\theta_{ae}$	external air temperature	$^{\circ}C$
$\theta_{ei}$	outdoor air temperature	$^{\circ}C$
$\theta_{em}$	outdoor air temperature of the heavy external components	$^{\circ}C$
$\theta_{es}$	outdoor air temperature of the light external components	$^{\circ}C$
$\theta_m$	mass temperature	$^{\circ}C$
$\theta_{op,av}$	daily average value of the operative temperature	$^{\circ}C$
$\theta_{op,min}$	daily minimum value of the operative temperature	$^{\circ}C$
$\theta_{op,max}$	daily maximum value of the operative temperature	$^{\circ}C$
$\theta_s$	star temperature	$^{\circ}C$
$\lambda$	thermal conductivity	$W/(m \cdot K)$
$\rho$	density	$kg/m^3$
$\rho_a$	density of air	$kg/m^3$
$\rho_{sr}$	solar reflectance	—
$\tau_{sr}$	solar direct transmittance	—
$\Phi$	heat flow rate	W

$\Phi_{co}$	transmission thermal load contribution	W
$\Phi_{er}$	heat flow rate due to the solar radiation through the glazing components	W
$\Phi_{erm}$	mean daily value of the heat flux due to the solar radiation through the glazing components	W
$\Phi_i$	heat flow to air node	W
$\Phi_{intc}$	convective heat flow of each internal source	W
$\Phi_{intr}$	radiative heat flow of each internal source	W
$\Phi_{is}$	internal source thermal load	W
$\Phi_m$	heat flow to mass node	W
$\Phi_s$	heat flow to star node	W
$\Phi_{sr}$	solar thermal load	W
$\Phi_{sv}$	thermal load due to the ventilation solar factor	W
$\Phi_T$	thermal load	W
$\Phi_V$	ventilation thermal load	W
$\varphi$	time lag of the density of heat flow rate	h
$\omega$	solar wall azimuth angle	degrees

### 3.3 Subscripts

a	air	va	ventilation through air cavity
b	building	cd	conduction
c	convection	ec	external ceiling
D	direct solar radiation	ef	external floor
d	diffuse solar radiation	eq	equivalent
e	external	ic	internal ceiling
g	ground	if	internal floor
i	internal	il	inlet section
l	leaving the section	lr	long-wave radiation
m	average	mr	mean radiant
n	normal to surface	op	operative
r	radiation	sa	solar to air
s	surface	sk	sky
sl	solar loss	t	time
sr	short wave radiation	v	ventilation

## 4 Input data and results

### 4.1 Assumptions

For the scope of this International Standard the following basic assumptions are made:

- the room is considered a closed space delimited by enclosure elements;
- the air temperature is uniform throughout the room;
- the various surfaces of the enclosure elements are isothermal;
- the thermophysical properties of the material composing the enclosure elements are constant;
- the heat conduction through each enclosure element is one dimensional;
- air spaces within the envelope elements are considered as air layers bounded by two isothermal surfaces;
- the mean radiant temperature is calculated as an area-weighted average of the radiant temperature at each internal surface;
- the operative temperature is calculated as the arithmetic mean value of the internal air temperature and the mean radiant temperature;
- the distribution of the solar radiation on the internal surfaces of the room is time-independent;
- the spatial distribution of the radiative part of the heat flow due to internal sources is uniform;
- the long-wave radiative and the convective heat transfers at each internal surface are treated separately;
- the dimensions of each component are measured at the internal side of the enclosure element;
- the effects of the thermal bridges on heat transfers are neglected.

### 4.2 Boundary conditions and input data

#### 4.2.1 Boundary conditions

##### 4.2.1.1 General

The elements of the envelope are divided into:

- external elements: these include the elements separating the internal environment from the outside and from other zones (i.e. attic, ground, crawl space);
- internal elements: these include the elements (vertical and horizontal) separating the internal environment from other rooms which can be considered to have the same thermal conditions.

##### 4.2.1.2 External elements

External elements are those separating the room from the external environment and from zones at different thermal conditions (e.g. attic, ground, crawl space).

Boundary conditions consist of defined hourly values of:

- external air temperature;
- intensity of the solar radiation on each orientation;
- sky radiant temperature;
- air temperature for the adjacent zones which cannot be considered at the same thermal conditions as the examined room.

For elements in contact with the ground the external temperature is assumed to be the mean monthly value of the external air temperature.

#### 4.2.1.3 Internal elements

Internal elements are those separating the room from other rooms which can be considered to have the same thermal conditions.

Internal elements are assumed to be adiabatic, which means that the values of the following quantities are considered to be the same on either side of the element:

- the air temperature;
- the mean radiant temperature;
- the solar radiation absorbed by the surface.

#### 4.2.2 Heat transfer coefficients

For the purposes of this International Standard the following values shall be used:

- internal convective heat transfer coefficient  $h_{ci} = 2,5 \text{ W}/(\text{m}^2 \cdot \text{K})$ ;
- internal long-wave radiative heat transfer coefficient  $h_{ri} = 5,5 \text{ W}/(\text{m}^2 \cdot \text{K})$ ;
- external convective heat transfer coefficient  $h_{ce} = 8,0 \text{ W}/(\text{m}^2 \cdot \text{K})$ ;
- external long-wave radiative heat transfer coefficient  $h_{re} = 5,5 \text{ W}/(\text{m}^2 \cdot \text{K})$ ;
- internal surface coefficient of heat transfer  $h_i = 8,0 \text{ W}/(\text{m}^2 \cdot \text{K})$ ;
- external surface coefficient of heat transfer  $h_e = 13,5 \text{ W}/(\text{m}^2 \cdot \text{K})$ .

#### 4.2.3 Geometrical and thermophysical parameters of the room envelope

##### 4.2.3.1 Opaque elements

For each element the following data are required:

- area calculated using the internal dimensions;
- thermal inertia characteristics (see ISO 13786);
- building elements in contact with the external air (see ISO 6946);
- building elements in contact with the ground (see ISO 13370).

The thermal inertia characteristics shall be determined according to ISO 13786.

The sunlit factor,  $f_s$ , is given by Equation (1):

$$f_s = \frac{A_s}{A} \quad (1)$$

where

$A_s$  is the area of the sunlit part of the wall (see 6.3);

$A$  is the total area of the wall.

NOTE The sunlit factor differs from the shading correction factor, defined in ISO 13790, which includes diffuse solar radiation.

The solar heat gain factor,  $S_f$ , is the ratio of the heat flow through the element due to the absorbed solar radiation, to the incident solar radiation. It is given by Equation (2):

— element with no air cavity (or closed air cavity):

$$S_f = \frac{\alpha_{sr} U}{h_e} \quad (2)$$

where

$\alpha_{sr}$  is the direct solar absorptance of the external surface;

$h_e$  is the external surface coefficient of heat transfer (defined in 4.2.2).

— element with open air cavity (external air):

$$S_f = f_v S_{fc} + (1 - f_v) S_{fv} \quad (3)$$

where

$f_v$  is the ventilation coefficient derived from Table 1 as a function of ventilation in the cavity;

$S_{fc}$  is the solar heat gain factor for the closed cavity;

$S_{fv}$  is the solar heat gain factor for the ventilated cavity, given by:

$$S_{fv} = \frac{\alpha_{sr}}{h_e} \left( \frac{U_e U_i}{U_e + U_i + h'} \right) \quad (4)$$

where

$U_e$  is the thermal transmittance between the external environment and the air cavity defined as in Equation (1);

$U_i$  is the thermal transmittance between the internal environment and the air cavity defined as in Equation (1);



with

$$h' = h_c \frac{(h_c + 2h_r)}{h_r} \quad (5)$$

where

$h_c$  is the convective heat transfer coefficient between the surface of the ventilated air layer and the air in the cavity;

$h_r$  is the radiative heat transfer coefficient between the two surfaces of the air layer.

Using the following values:

$$h_c = 5 \text{ W/(m}^2\cdot\text{K)}$$

$$h_r = 5 \text{ W/(m}^2\cdot\text{K)}$$

$$h' = 15 \text{ W/(m}^2\cdot\text{K)}$$

Table 1 gives the ventilation coefficient  $f_v$  depending on the ratio between the cavity area ( $A_c$ ) and the wall area ( $A_w$ ).

The cavity area is the air flow area; the wall area is the conduction heat flow area.

**Table 1 — Ventilation coefficient  $f_v$**

	$A_c/A_w \leq 0,005$	$0,005 < A_c/A_w \leq 0,10$	$0,10 < A_c/A_w$
$f_v$	0,8	0,5	0,2

In the absence of an actual measured value, the direct solar absorptance of the external surface may be derived from Table 2 as function of its colour.

**Table 2 — Direct solar absorptance of external surface**

	Light colour	Medium colour	Dark colour
$\alpha_{sr}$	0,3	0,6	0,9

#### 4.2.3.2 Glazed elements

For each glazed element the following data are required:

- area calculated, including the frame;
- thermal transmittance ( $U$  value);
- total solar direct transmittance,  $S_{f1}$  ( $\tau_v$  in ISO 9050 and EN 410);
- secondary heat transfer factor,  $S_{f2}$ , of the glazing by convection and long-wave radiation due to the absorbed solar radiation;
- tertiary heat transfer factor,  $S_{f3}$ , of the glazing by ventilation due to the absorbed solar radiation;
- the sunlit factor due to external obstruction,  $f_s$ .

The thermal transmittance,  $U$ , is determined according to EN 673 and ISO 10077-1.

The solar direct transmittance,  $S_{f1}$ , ( $\tau_v$ ), and the secondary and tertiary heat transfer factors  $S_{f2}$  and  $S_{f3}$  are determined from EN 13363-1.

#### a) Solar-to-air factor

The solar-to-air factor,  $f_{sa}$ , is the fraction of solar heat entering the room through the glazing which is immediately transferred to the internal air. This fraction depends on the presence of internal elements with very low heat capacity, such as carpets and furniture. It is assumed to be time-independent and, unless otherwise specified, the values in ISO 13791 may be used.

#### b) Solar loss factor

The solar loss factor,  $f_{sl}$ , is the fraction of the solar radiation entering the room which is reflected back outside. It depends on the solar position, solar properties, dimensions and exposure of the glazing system, the room geometry and the reflectivity of the internal room surfaces. It is assumed to be time-independent. Unless otherwise specified, the values of  $f_{sl}$  in ISO 13791 may be used.

The procedure for evaluating the sunlit factor due to external obstruction,  $f_s$ , can be defined in national standards. Such a procedure is given in Annex C.

### 4.2.3.3 Special elements

#### a) Ceiling below attic

The element formed by the ceiling, the air space and the roof is considered as a single horizontal element with one-dimensional heat flow. The air space is considered as an air cavity and treated according to ISO 6946.

#### b) Floor on ground

The ground formed by the floor and the soil is considered as a single horizontal layer, which may include an air gap. The heat flow through the element is the sum of a monthly mean value and a variable term. The monthly mean value is calculated using the mean internal and external temperatures, and (taken as constant and equal to the mean monthly value) the thermal transmittance determined according to ISO 13370. The variable term is calculated assuming the mean temperature difference is zero. The depth of soil is taken to be 0,5 m.

#### c) Cellar

A cellar can be considered as an adjacent room with fixed air temperature.

#### d) Crawl space

A crawl space is treated as a floor on ground according to ISO 13370.

### 4.2.4 Air change rate

The air change rate depends on the tightness of the envelope and on the opening of any doors and windows.

At a design stage the air change rate is expressed as a function of the:

- location of the building;
- pattern of air ventilation;
- number of facades with windows.

The location may be categorized as:

- city centre area;
- suburban area;
- open area.

The pattern of air ventilation is related to the time schedule of the opening and closing of windows and whether windows are located on one or on more facades.

The following time schedules are considered:

- windows open day and night;
- windows closed day and night;
- window closed during the day and open during the night.

Data on the time of opening and closing of the windows and on hourly air change rates can be defined at a national level. Annex B gives examples of appropriate values of the air change rates.

#### **4.2.5 Internal gain**

Internal gains derive from lighting, equipment and occupant. The pattern of the heat flow due to internal gains is related to the occupants' behaviour and to the utilisation of the room.

Data on the time schedule of utilization of the room, and the heat flow for each type of utilization, can be defined at a national level. If information is not available, the values included in Annex D can be used.

### **4.3 Output data**

Results of the calculations are the maximum, average and minimum daily values of the operative temperature of the considered room under defined external and internal conditions.

## **5 Calculation procedure**

The calculation procedure is based on the following steps:

- a) definition of the climatic data of the location in accordance with the procedures described in ISO 15927-2;
- b) definition of the room for which the control is required;
- c) definition of the elements of the envelope enclosing the room (area, exposure, boundary conditions);
- d) calculation of the thermophysical parameters (steady state and transient conditions) and the solar energy transmittance of opaque and transparent elements;
- e) definition of the ventilation pattern;
- f) definition of the internal gains;
- g) evaluation of the maximum, average and minimum daily values of the operative temperature.

The level of accuracy of a calculation procedure shall be checked using the validation procedure given in Clause 6, leading to a classification into one of three accuracy classes 1, 2 and 3 (see 6.2).

## 6 Validation procedures

### 6.1 Introduction

This International Standard does not impose any specific calculation method for the evaluation of the operative temperature of a single room nor for the calculation of the sunlit factor. The cases used in Clause 6 are based on ISO 13791.

### 6.2 Validation procedure for the calculation method

#### 6.2.1 General

The model validation includes the calculation of the operative temperature under cyclic conditions for several cases indicated below, and the comparisons of these values with those reported in Table 11.

#### 6.2.2 Geometry

The values of geometrical characteristics of the rooms are given in Table 3.

Table 3 — Room data

Element	Geometry A area m <sup>2</sup>	Geometry B area m <sup>2</sup>
External opaque wall	6,58	3,08
Glazing area	3,50	7,00
Partition wall (left)	15,40	15,40
(right)	15,40	15,40
(back)	10,08	10,08
Floor	19,80	19,80
Ceiling	19,80	19,80
Volume, m <sup>3</sup>	55,44	55,44

The room geometry is shown in Figure 1.

Dimensions in metres

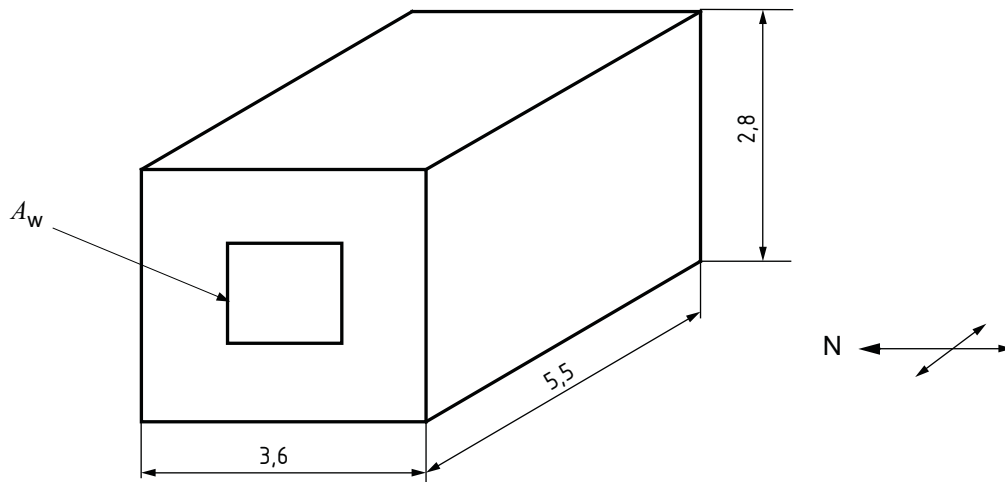

Figure 1 — Room geometries A and B

### 6.2.3 Description of elements

The thermophysical characteristics of the walls, ceiling and floor are reported in Table 4. The thermophysical properties of the glass panes composing the glazing system and the external shade are reported in Figure 2.

As far as these test cases are concerned, the solar properties of glass panes are independent of the angle of incidence. The optical properties of each panel are reported in Table 5.

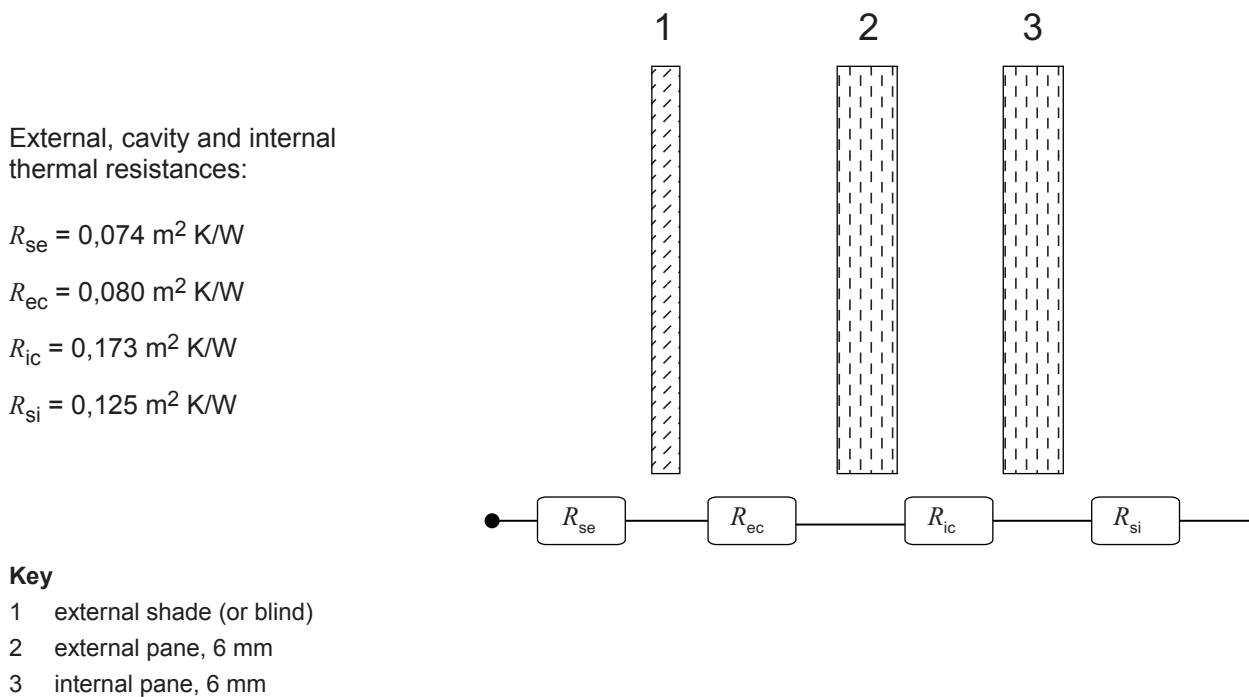

Figure 2 — Double pane (DP) glazing system with external shading device

**Table 4 — Thermophysical properties of the opaque components**

	$d$ m	$\lambda$ W/(m·K)	$\rho$ kg/m <sup>3</sup>	$c$ kJ/(kg·K)
<b>Type no. 1 (external wall)</b>				
Outer layer	0,115	0,99	1 800	0,85
Insulation layer	0,06	0,04	30	0,85
Masonry	0,175	0,79	1 600	0,85
Internal plastering	0,015	0,70	1 400	0,85
<b>Type no. 2 (internal wall)</b>				
Gypsum plaster	0,012	0,21	900	0,85
Mineral wool	0,10	0,04	30	0,85
Gypsum plaster	0,012	0,21	900	0,85
<b>Type no. 3 (ceiling/floor)</b>				
Floor covering	0,004	0,23	1 500	1,5
Concrete floor	0,06	1,40	2 000	0,85
Insulation	0,04	0,04	50	0,85
Concrete	0,18	2,10	2 400	0,85
<b>Type no. 4 (ceiling/floor)</b>				
Plastic floor covering	0,00 4	0,23	1 500	1,5
Concrete floor	0,06	1,40	2 000	0,85
Insulation	0,04	0,04	50	0,85
Concrete	0,18	2,10	2 400	0,85
Mineral wool	0,10	0,04	50	0,85
Acoustic board	0,02	0,06	400	0,84
<b>Type no. 5 (roof)</b>				
External layer	0,00 4	0,23	1 500	1,3
Insulation	0,08	0,04	50	0,85
Concrete	0,20	2,1	2 400	0,85

**Table 5 — Solar characteristics of the glazed element and the shade for all incident angles**

Component	$\tau_{sr}$	$\rho_{sr}$
Pane	0,84	0,08
Shade	0,2	0,50

#### 6.2.4 Combination of elements

Three combinations of elements are considered as given in Table 6. The numbers in Table 6 refer to the wall types in Table 4. For the definition of adiabatic see 4.2.1.3.

Table 6 — Test cases

Test no.	External opaque wall	Internal adiabatic wall	Adiabatic ceiling	Adiabatic floor	Roof
1	1	2	4	4	
2	1	2	3	3	
3	1	2		3	5

### 6.2.5 Climatic data

The climatic data are given in Tables 7, 8 and 9.

Table 7 — Solar radiation 15 July

Hour	Geometry A (latitude 40°N)		Geometry B (latitude 52°N)	
	Horizontal W/m <sup>2</sup>	Vertical west W/m <sup>2</sup>	Horizontal W/m <sup>2</sup>	Vertical west W/m <sup>2</sup>
4	0	0	0	0
5	4	2	69	22
6	168	45	225	55
7	369	78	388	80
8	557	103	539	101
9	719	122	669	117
10	842	137	768	128
11	920	145	831	135
12	946	160	852	150
13	920	381	831	366
14	842	576	768	558
15	719	720	669	703
16	557	787	539	778
17	369	740	388	756
18	168	511	225	604
19	4	20	69	271
20	0	0	0	0

Any combination of solar parameters that leads to the values given in Table 7 is acceptable.

**Table 8 — External air temperature for Geometry A (15 July, latitude 40°N)**

Hour	$\theta_{ao}$ °C	Hour	$\theta_{ao}$ °C	Hour	$\theta_{ao}$ °C	Hour	$\theta_{ao}$ °C
1	23,6	7	22,8	13	32,7	19	29,9
2	23,0	8	23,9	14	33,6	20	28,4
3	22,5	9	25,8	15	34,0	21	27,0
4	22,1	10	27,3	16	33,6	22	25,8
5	22,0	11	29,3	17	32,8	23	24,9
6	22,2	12	31,2	18	31,5	24	24,2

**Table 9 — External air temperature for Geometry B (15 July, latitude 52°N)**

Hour	$\theta_{ao}$ °C	Hour	$\theta_{ao}$ °C	Hour	$\theta_{ao}$ °C	Hour	$\theta_{ao}$ °C
1	14,1	7	13,1	13	26,2	19	22,6
2	13,3	8	14,6	14	27,5	20	20,5
3	12,6	9	16,6	15	28,0	21	18,7
4	12,2	10	19,0	16	27,5	22	17,1
5	12,0	11	21,8	17	26,4	23	15,8
6	12,3	12	24,3	18	24,6	24	14,9

The values of the solar radiation and temperatures reported in Tables 7, 8 and 9 correspond to instantaneous value at the given hour (for example the solar radiation is 225 W/m<sup>2</sup> for a horizontal surface at 6:00). The evolution during an hour is assumed to be linear between the value at the beginning and the end of the hour. The input data have to be adapted to each calculation method following these assumptions.

The sky radiant temperature is equal to external air temperature.

### 6.2.6 Internal energy sources

The total heat flow rate per floor area due to internal sources is given in Table 10. The heat flow is assumed to be transferred to the room by convection and radiation in equal proportions (50 % for each).

**Table 10 — Total heat flow due to internal sources per floor area**

Hour	$\Phi_{ic}$ W/m <sup>2</sup>	Hour	$\Phi_{ic}$ W/m <sup>2</sup>	Hour	$\Phi_{ic}$ W/m <sup>2</sup>	Hour	$\Phi_{ic}$ W/m <sup>2</sup>
0 to 1	0	6 to 7	0	12 to 13	10	18 to 19	15
1 to 2	0	7 to 8	1	13 to 14	10	19 to 20	15
2 to 3	0	8 to 9	1	14 to 15	10	20 to 21	15
3 to 4	0	9 to 10	1	15 to 16	1	21 to 22	15
4 to 5	0	10 to 11	1	16 to 17	1	22 to 23	10
5 to 6	0	11 to 12	10	17 to 18	1	23 to 24	0

The daily total value of the internal gains is 117 Wh/m<sup>2</sup>.



### 6.2.7 Ventilation pattern

Three different ventilation patterns are considered, with air change rates as follows:

- a) 1 h<sup>-1</sup>, constant;
- b) 0,5 h<sup>-1</sup> from 06:00 to 18:00 and 10 h<sup>-1</sup> from 18:00 to 06:00;
- c) 10 h<sup>-1</sup> constant.

The characteristics of air are as follows:

- specific heat capacity: 1 008 J/(kg·K);
- density: 1,139 kg/m<sup>3</sup>.

### 6.2.8 Test results

For each test the following data, determined in cyclic conditions, shall be calculated:

- daily average value of the operative temperature,  $\theta_{op,av}$
- daily minimum value of the operative temperature,  $\theta_{op,min}$
- daily maximum value of the operative temperature,  $\theta_{op,max}$

The maximum and minimum value are extracted from the 24 hourly values obtained as the average for each hour (e.g. from 07:00 to 08:00).

NOTE More information is given in P. Romagnoni and J.-R. Millet in the ASHRAE Transactions 2002, V. 108, Pt 2.

**Table 11 — Reference values of the operative temperature**

Room	Ventilation	$\theta_{op,max}$ °C	$\theta_{op,av}$ °C	$\theta_{op,min}$ °C
A.1	a)	38,8	35,9	33,6
	b)	34,1	29,5	25,6
	c)	33,6	29,1	25,4
A.2	a)	37,7	35,9	34,5
	b)	32,3	29,5	26,6
	c)	32,4	29,1	26,4
A.3	a)	40,6	38,6	37,0
	b)	35,0	31,4	28,0
	c)	33,6	30,2	27,4
B.1	a)	35,9	30,8	27,1
	b)	30,0	22,3	16,5
	c)	28,3	21,6	16,3
B.2	a)	33,9	30,8	28,6
	b)	26,9	22,3	18,1
	c)	26,5	21,6	17,8
B.3	a)	35,8	32,5	30,2
	b)	29,3	24,0	19,2
	c)	27,5	22,6	18,7

Each test case is classified into one of three classes 1, 2, 3 on the basis of the difference  $\Delta$  between the calculated value and the reference value. The considered procedure is classified according to the worst resulting test. For the three classes, the limiting  $\Delta$  values are as follows. The following classes are defined:

Class 1: +1 K to -1 K

Class 2: +2 K to -1 K

Class 3: +3 K to -1 K

### 6.3 Validation procedure for the sunlit factor due to external obstructions

The calculation of the sunlit factor, defined in ISO 13791, is to be validated for a vertical surface with the following dimensions:

Height: 2,8 m

Width: 3,6 m



Dimensions in metres

Figure 3 — Dimensions of the wall for test cases

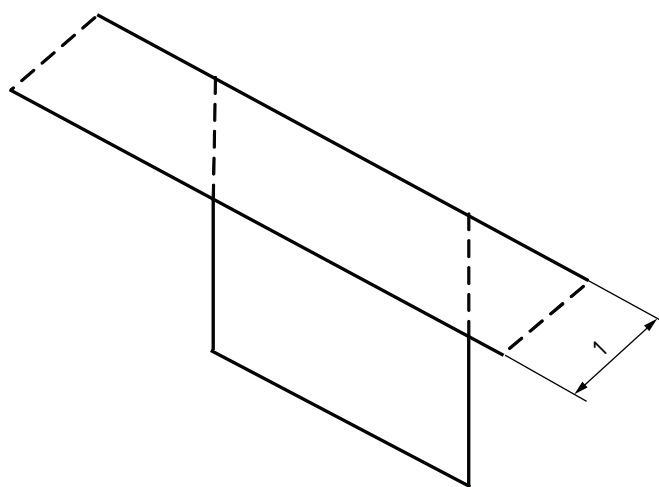

Dimensions in metres

a) Test No. 1: Infinite horizontal overhang — South orientation (north hemisphere)

Figure 4 (continued)

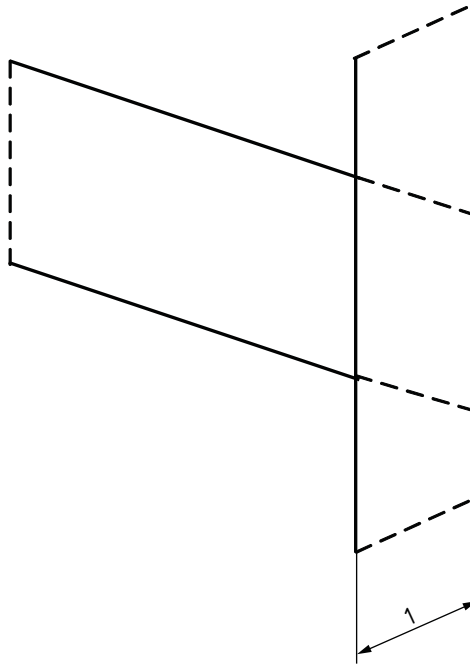

b) Test No. 2: Infinite right side fin — West orientation

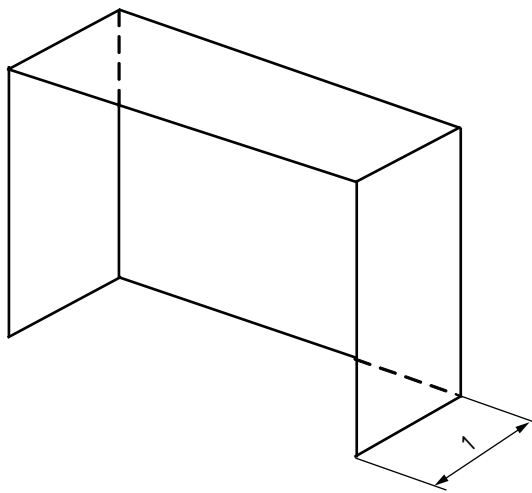

c) Test No. 3: Loggia — South orientation (northern hemisphere)

Figure 4 — Test cases

Table 12 gives results for the reference sunlit factor,  $f_s$ , obtained for the three test cases.

It also gives, for information, the value of projection of the azimuthal solar angle compared to the wall perpendicular vector,  $\theta$ .

Table 12 — Reference values of the sunlit factor

Hour	Test case 1		Test case 2		Test case 3	
	$\theta$	$f_s$	$\theta$	$f_s$	$\theta$	$f_s$
0,5	—	—	—	—	—	—
1,5	—	—	—	—	—	—
2,5	—	—	—	—	—	—
3,5	—	—	—	—	—	—
4,5	—	—	—	—	—	—
5,5	—	—	—	—	—	—
6,5	—	—	—	—	—	—
7,5	86,8	0,0	—	—	86,8	0,00
8,5	77,2	0,00	—	—	77,3	0,00
9,5	69,0	0,26	—	—	69,0	0,15
10,5	63,0	0,36	—	—	63,0	0,28
11,5	59,8	0,39	—	—	59,8	0,37
12,5	59,8	0,39	83,0	0,00	59,8	0,37
13,5	63,0	0,36	69,1	0,65	63,0	0,28
14,5	69,0	0,26	55,5	0,82	69,0	0,15
15,5	77,2	0,00	42,4	0,92	77,2	0,00
16,5	86,8	0,00	30,7	0,98	86,8	0,00
17,5	—	—	22,6	1,00	—	—
18,5	—	—	22,6	1,00	—	—
19,5	—	—	30,7	1,00	—	—
20,5	—	—	42,2	1,00	—	—
21,5	—	—	53,8	1,00	—	—
22,5	—	—	64,5	1,00	—	—
23,5	—	—	72,2	1,00	—	—

For each case, the absolute difference between the calculated  $f_s$  value and the reference must be less than 0,05.

## Annex A (informative)

### Examples of solution model

#### A.1 Introduction

This annex gives two examples of simple calculation methods for the evaluation of the operative temperature of a room according to the type of inputs defined in this International Standard.

The calculation methods are based on the following representation of the heat transfer processes:

- a network of resistances and capacities (RC three-nodes model) of the heat transfers between the internal and external environment;
- separation of the steady state contribution from the variable contribution described by predetermined harmonic heat transfer parameters (admittance procedure).

#### A.2 RC three-nodes model

##### A.2.1 Presentation

The calculation model is based on the simplifications of the heat transfer between the internal and external environment reported in the following figure.

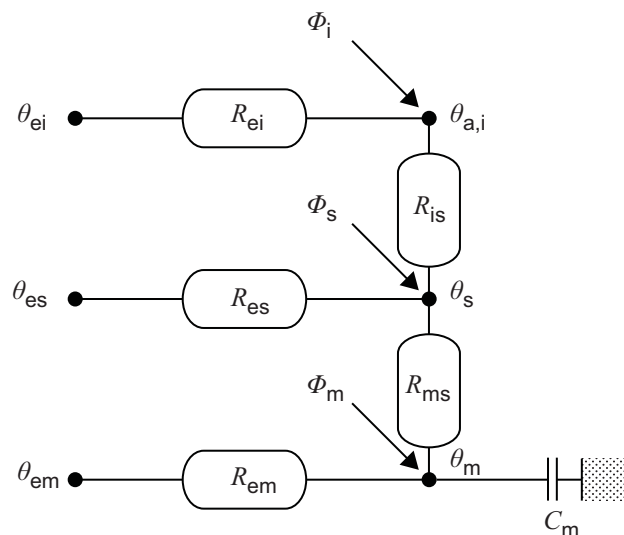

Figure A.1 — Network of resistances and capacities (RC three-nodes model)

According to Figure A.1 the envelope components are divided as:

- light opaque external components;
- heavy opaque external components;
- glazing components;
- internal components.

The relevant nodes are defined related to:

- $\theta_{a,i}$  indoor air temperature;
- $\theta_s$  star temperature;
- $\theta_m$  mass temperature;
- $\theta_{ei}$  outdoor air temperature;
- $\theta_{es}, \theta_{em}$  equivalent outdoor air temperature of external components.

The equivalent resistances, expressed in K/W, and heat capacity, expressed in J/K, between the internal and the external environment considered are:

- $R_{ei}$  thermal resistance due to air ventilation;
- $R_{es}, R_{em}$  thermal resistances of external components between outside and inside;
- $R_{is}, R_{ms}$  thermal resistance corresponding to the heat exchanges, between the internal surfaces and the internal air;
- $C_m$  heat capacity of the enclosure elements.

The heat flows, expressed in W, considered are:

- $\Phi_i$  heat flow to  $\theta_i$  node;
- $\Phi_s$  heat flow to  $\theta_s$  node;
- $\Phi_m$  heat flow to  $\theta_m$  node.

For each component the parameters listed in Table A.1 are required.

Table A.1 — Parameters for the room components

Description	Quantity	Symbol
— light opaque external components (depth ≤ 12 cm)	thermal transmittance	$U$
	solar heat gain factor	$S_f$
	solar radiation	$I_{sr}$
	area	$A$
— heavy opaque external components (depth > 12 cm)	thermal transmittance	$U$
	solar heat gain factor	$S_f$
	solar radiation	$I_{sr}$
	area	$A$
— glazing components	thermal transmittance	$U$
	solar direct transmittance ( $\tau_v$ in ISO 9050 and EN 410)	$S_{f1}$
	secondary heat transfer factor towards inside ( $q_i$ in ISO 9050 and EN 410)	$S_{f2}$
	tertiary heat transfer coefficient	$S_{f3}$
	solar radiation	$I_{sr}$
	area	$A$
— all components	heat capacity per area	$C$
	area	$A$
— room	air changes per hour	$n$
	room volume	$V$

### A.2.2 Determination of the air and operative temperatures

The solution model is based on the scheme of Crank-Nicolson considering a time step of one hour. The temperatures are the average between time  $t$  and  $t - 1$  except for  $\theta_{m,t}$  and  $\theta_{m,t-1}$  that are instantaneous values at time  $t$  and  $t - 1$ .

For a given time step,  $\theta_{m,t}$  is calculated from the previous value  $\theta_{m,t-1}$  by Equation (A.1):

$$\theta_{m,t} = \frac{\theta_{m,t-1} \left( \frac{C_m}{3\,600} - 0,5 \times (H_3 + H_{em}) \right) + \Phi_{mtot}}{\left( \frac{C_m}{3\,600} + 0,5 \times (H_3 + H_{em}) \right)} \quad (\text{A.1})$$

For the time step considered, the average values of node temperatures are given by Equations (A.2), (A.3) and (A.4):

$$\theta_m = \frac{\theta_{m,t} + \theta_{m,t-1}}{2} \quad (\text{A.2})$$

$$\theta_s = \frac{H_{ms}\theta_m + \Phi_s + H_{es}\theta_{es} + H_1 \left( \theta_m + \frac{\Phi_i}{H_{ei}} \right)}{H_{ms} + H_{es} + H_1} \quad (\text{A.3})$$

$$\theta_i = \frac{H_{is}\theta_s + H_{ei}\theta_{ei} + \Phi_i}{H_{is} + H_{ei}} \quad (\text{A.4})$$

and the operative temperature (average between air and mean radiant temperature) by Equation (A.5):

$$\theta_{op} = \frac{\theta_i + \left(1 + \frac{h_{ci}}{h_{rs}}\right)\theta_s - \left(\frac{h_{ci}}{h_{rs}}\right)\theta_i}{2} \quad (\text{A.5})$$

with

$$h_{rs} = 1,2 \times h_{ri}$$

$$H_1 = \frac{1}{\frac{1}{H_{ei}} + \frac{1}{H_{is}}}$$

$$H_2 = H_1 + H_{es}$$

$$H_3 = \frac{1}{\frac{1}{H_2} + \frac{1}{H_{ms}}}$$

$$\Phi_{mtot} = \frac{\Phi_m + H_{em}\theta_{em} + H_3 \left[ \Phi_s + H_{es}\theta_{es} + H_1 \left( \frac{\Phi_i}{H_{ei}} + \theta_{ei} \right) \right]}{H_2}$$

where

$H_{ei}$  is the heat transfer coefficient due to the air ventilation given by Equation (A.6);

$H_{is}$  is the heat transfer coefficient due to internal exchanges by convection and radiation given in Equation (A.7);

$H_{es}$  is the global heat transfer coefficient between the internal and external environment given by Equation (A.8);

$H_{ms}$  is the conventional internal heat transfer coefficient given by Equation (A.9);

$H_{em}$  is the conventional heat transfer coefficient between the external environment and the internal surface of the heavy components given by Equation (A.10);

$C_m$  is the heat capacity of the envelope components given by Equation (A.11);

$\theta_{es}$  is the equivalent outdoor air temperature of the light external components given by Equation (A.13);

$\theta_{em}$  is the equivalent outdoor air temperature of the heavy external components given by Equation (A.14);

$\Phi_i$  is the heat flow to air node due to internal sources or direct solar radiation or convective heat gains due to window ventilated inner air layer given by Equation (A.21);

$\Phi_s$  is the heat flow to star node due to internal sources or direct solar radiation given by Equation (A.22);



$\Phi_m$  is the heat flow to mass node due to internal sources or direct solar radiation given by Equation (A.23).

The calculation is repeated for several cycles until the convergence on the internal temperature values is obtained. The convergence is obtained if the difference between the  $\theta_m$  24 h temperature of two subsequent cycles is less than 0,01 °C.

### A.2.3 Terms in Equations (A.1), (A.2), (A.3), (A.4) and (A.5)

The different terms are the following:

#### Heat transfer coefficients

Heat transfer coefficient due to the air ventilation:

$$H_{ei} = \frac{c_a \rho_a n V}{3600} \quad (\text{A.6})$$

where

$c_a$  is the specific heat of the ventilation air [1 000 J/(kg·K)];

$n$  is the air change per hour;

$V$  is the room volume in m<sup>3</sup>;

$\rho_a$  is the density of the ventilation air.

$$H_{is} = \frac{A_t}{\frac{1}{h_{ci}} - \frac{1}{h_{is}}} \quad (\text{A.7})$$

where

$$h_{is} = h_{ci} + h_{rs};$$

$$A_t = \sum_{i=1}^{N_C} A_i$$

$A_t$  is the total exposed area of components facing the internal environment.

$$H_{es} = H_{Tl} + H_{Tw} \quad (\text{A.8})$$

where

$$H_{Tl} = \sum_{k=1}^{N_l} A_k U_k$$

$$H_{Tw} = \sum_{j=1}^{N_w} A_j U_j$$

$H_{es}$  corresponds to light external opaque components,  $H_{Tl}$ , and windows,  $H_{Tw}$ .

$$H_{ms} = h_{is} A_m \quad (\text{A.9})$$

$A_m$  is given in Equation (A.12).

$$H_{em} = \frac{1}{\frac{1}{H_{Th}} - \frac{1}{H_{ms}}} \quad (\text{A.10})$$

where

$$H_{Th} = \sum_{y=1}^{N_h} A_y U_y$$

$H_{Th}$  corresponds to heavy external opaque components.

The thermal mass of the structure  $C_m$  is calculated in Equation (A.11) in accordance with ISO 13786 for a 24 h period variation:

$$C_m = \sum_{i=1}^{N_c} A_i C_i \quad (\text{A.11})$$

where

$C_i$  is the equivalent internal heat capacity of the component;

$A_i$  is the area of the component;

$N_c$  is the number of components facing the indoor environment (e.g. both internal and external components).

The equivalent thermal mass area  $A_m$  is given by Equation (A.12):

$$A_m = \frac{C_{m2}}{\sum_{i=1}^{N_c} A_i C_{i2}} \quad (\text{A.12})$$

Equivalent outdoor temperatures:

$$\theta_{es} = \theta_{ei} + \frac{\Phi_{sl}}{H_{es}} \quad (\text{A.13})$$

$$\theta_{em} = \theta_{ei} + \frac{\Phi_{sh}}{H_{Th}} \quad (\text{A.14})$$

The solar radiation reaching the surface of the building envelope components is given by:

$$I_{sr} = f_s I_D + I_d + I_r$$

where

$f_s$  is the sunlit factor;

$I_D$  is the direct component of the solar radiation reaching the surface;

$I_d$  is the diffuse component of the solar radiation reaching the surface;

$I_r$  is the reflected component of the solar radiation reaching the surface.

The heat flow due to the solar radiation absorbed and the sky vault losses by the light components (opaque and transparent) are given by Equation (A.15):

$$\Phi_{sl} = \sum_{k=1}^{N_l} \left[ A \left( S_f I_{sr} - q_{er} \frac{U}{h_e} \right) \right]_k + \sum_{j=1}^{N_w} \left[ A \left( S_{f2} I_{sr} - q_{er} \frac{U}{h_e} \right) \right]_j \quad (\text{A.15})$$

The heat flow due to the solar radiation absorbed and the sky vault losses by the opaque heavy components are given by Equation (A.16):

$$\Phi_{sh} = \sum_{y=1}^{N_h} \left[ A \left( S_f I_{sr} - q_{lr} \frac{U}{h_e} \right) \right]_y \quad (\text{A.16})$$

### Heat flows to node temperatures

The heat flow due to solar radiation directly transmitted through the windows is given by Equation (A.17):

$$\Phi_{sd} = \sum_{j=1}^{N_w} \left[ A (1 - f_{sl}) S_{f1} I_{sr} \right]_j \quad (\text{A.17})$$

The total heat flow due to solar radiation transmitted by the temperature increase of air passing through window inner ventilated air layers is given by Equation (A.18):

$$\Phi_{svl} = \sum_{j=1}^{N_w} \left[ (A S_{f3} I_{sr}) \right]_j \quad (\text{A.18})$$

The heat flows due to the internal sources are given by Equations (A.19) and (A.20):

$$\Phi_{intc} = \sum_{i=1}^{N_s} \Phi_{intc,i} \quad (\text{A.19})$$

$$\Phi_{intr} = \sum_{i=1}^{N_s} \Phi_{intr,i} \quad (\text{A.20})$$

where

$N_s$  is the number of internal sources;

$\Phi_{\text{intc}}$  is the convective heat flow of each internal source;

$\Phi_{\text{intr}}$  is the radiative heat flow of each internal source.

The heat flows to temperature nodes are given by Equations (A.21), (A.22) and (A.23):

$$\Phi_i = \Phi_{\text{svl}} + f_{\text{sa}} \Phi_{\text{sd}} + \Phi_{\text{intc}} \quad \text{to air node} \quad (\text{A.21})$$

$$\Phi_s = P_{\text{rs}} (1 - f_{\text{sa}}) \Phi_{\text{intr}} + P_{\text{rsd}} \Phi_{\text{sd}} \quad \text{to star node} \quad (\text{A.22})$$

$$\Phi_m = P_{\text{rm}} (1 - f_{\text{sa}}) \Phi_{\text{intr}} + P_{\text{rmd}} \Phi_{\text{sd}} \quad \text{to mass node} \quad (\text{A.23})$$

where  $P_{\text{rs}}$  and  $P_{\text{rm}}$  are the parts of the internal radiative gains respectively to  $\theta_s$  and  $\theta_m$  nodes.

$$P_{\text{rs}} = \frac{A_t - A_m - \frac{H_{\text{es}}}{h_{\text{is}}}}{A_t} \quad (\text{A.24})$$

$$P_{\text{rm}} = \frac{A_m}{A_t} \quad (\text{A.25})$$

$P_{\text{rsd}}$  and  $P_{\text{rmd}}$  are the parts of the direct solar radiative gains respectively to  $\theta_s$  and  $\theta_m$  nodes, assuming that the solar short wave radiation back to the window is already taken into account in the solar loss coefficient  $f_{\text{sl}}$ .

$$P_{\text{rsd}} = \frac{A_t - A_m - A_w - \frac{H_{\text{es}}}{h_{\text{is}}}}{A_t - A_w} \quad (\text{A.26})$$

$$P_{\text{rmd}} = \frac{A_m}{A_t - A_w} \quad (\text{A.27})$$

$A_w$  is the total window area, given by:

$$A_w = \sum_{j=1}^{N_w} A_j$$

where

$N_l$  is the number of light opaque components;

$N_w$  is the number of glazing components;

$N_h$  is the number of heavy opaque components;

$S_f$  is the solar heat gain factor of each opaque component;

$S_{f1}$  is the window solar direct transmittance;

$S_{f2}$  is the window secondary solar factor;

$S_{f3}$  is the window tertiary heat transfer factor;

$I_{sr}$  is the intensity of the solar radiation reaching the surface;

$f_{sl}$  is the solar loss factor for windows;

$f_s$  is the sunlit factor due to external obstructions, derived from EN 410;

$f_{sa}$  is the solar to air factor defined in EN 410;

$q_{lr}$  is the density of heat flow from the external environment to the sky vault.

## A.3 Admittance procedure

### A.3.1 Thermophysical parameters of the envelope components

#### Heat transmission parameters

External wall:

$U$  is the thermal transmittance;

$F_a$  is the decrement factor;

$\varphi$  is the time lag of the density of heat flow rate at the internal surface resulting from a harmonic variation of the temperature on the external surface;

$F_s$  is the surface factor;

$Y_e$  is the admittance.

Internal wall:

$F_s$  is the surface factor;

$Y_i$  is the admittance.

#### Solar parameters

Opaque components:

$S_f$  is the solar heat gain factor;

$f_s$  is the sunlit factor due to external obstructions.

Transparent components:

$S_{f1}$  is the solar direct transmittance ( $\tau_v$  in ISO 9050 and EN 410);

$S_{f2}$  is the secondary heat transfer factor to inside;

$S_{f3}$  is the tertiary heat transfer factor;

$f_s$  is the sunlit factor (see 4.2.3.2).

The transient parameters of the opaque components are determined from the four elements of the matrix transfer,  $Z$ , evaluated according to ISO 13786 for a time period of 24 h, using the following surface resistances:

External component:

internal surface:  $R_{si} = 0,22 \text{ m}^2 \cdot \text{K/W}$

external surface:  $R_{se} = 0,075 \text{ m}^2 \cdot \text{K/W}$

Internal component:

internal both surfaces:  $R_{si} = 0,22 \text{ m}^2 \cdot \text{K/W}$

NOTE These values refer to a room with two external walls and a roof. This geometry is assumed as reference for the calculation of the transient parameters.

The procedure for determining the transient parameters, required by the calculation method, is the following:

### Decrement factor and time lag

The decrement factor is given by the modulus of the complex number defined in Equations (A.28) and (A.29) as:

$$f_c = \frac{1}{U Z_{12}} \quad (\text{A.28})$$

$$F_a = |f_c| \quad (\text{A.29})$$

$Z_{12}$ ,  $Z_{22}$ , etc., are terms of the matrix  $Z$  (see above). Time lag is given by Equation (A.30):

$$\phi = \frac{12}{\pi} \arg \left( \frac{I_m(f_c)}{R_e(f_c)} \right) \quad (\text{A.30})$$

where

$I_m$  is the imaginary part of the complex number  $f_c$ ;

$R_e$  is the real part of the complex number  $f_c$ .

The argument is evaluated in the field  $\pi$  to 0 radians. In this case  $\phi$  represents the time lag.

For transparent components the decrement factor is assumed to be equal to 1, and the time lag is assumed to be 0.

### Surface factor $F_s$

— external component:

$$F_s = 1 - R_{si} \left| \frac{Z_{11}}{Z_{12}} \right| \quad (\text{A.31})$$

— internal component:

$$F_s = 1 - R_{si} \left| \frac{Z_{11} - 1}{Z_{12}} \right| \quad (\text{A.32})$$

where  $| \cdot |$  denotes the modulus of a complex number.

### Admittance $Y$

— external component

$$Y_e = \left| \frac{Z_{11}}{Z_{12}} \right| \quad (\text{A.33})$$

— internal component:

$$Y_i = \left| \frac{Z_{11} - 1}{Z_{12}} \right| \quad (\text{A.34})$$

## A.3.2 Calculation of the internal air temperature

### A.3.2.1 General

The internal air temperature at a given time  $t$  is given by Equation (A.35):

$$\theta_{ai,t} = \frac{\Phi_{T,t} + (Y_T - H_T) \theta_{ai,m}}{Y_T + H_{ei,t}} \quad (\text{A.35})$$

where

$\Phi_T$  is the thermal load (determined in A.3.2.2.1), in W;

$Y_T$  is the total admittance of the envelope, in W/K;

$H_{ei,t}$  is the heat transfer coefficient of the envelope, in W/K;

$\theta_{ai,m}$  is the average daily value of the indoor air temperature, in °C.

### A.3.2.2 Terms included in Equation (A.35)

#### A.3.2.2.1 Thermal load $\Phi_T$

The thermal load at any given time  $t$  is given by Equation (A.36):

$$\Phi_{T,t} = f_c \Phi_{co,t} + f_r \Phi_{sr,t} + \Phi_{v,t} + \Phi_{is} + \Phi_{sv} \quad (\text{A.36})$$

where

$\Phi_{co}$  is the transmission thermal load contribution;

$\Phi_{sr}$  is the solar thermal load;

$f_c$  is the correction factor for transmission thermal load;

- $f_r$  is the correction factor for solar thermal load;  
 $\Phi_v$  is the ventilation thermal load;  
 $\Phi_{is}$  is the internal source thermal load;  
 $\Phi_{sv}$  is the thermal load due to the ventilation solar factor.

### Transmission thermal load $\Phi_{co}$

The transmission thermal load  $\Phi_{co}$ , at any given time  $t$ , is given by Equation (A.37):

$$\Phi_{co,t} = \sum_{j=1}^{N_p} \Phi_{op,j} + \sum_{j=1}^{N_w} \Phi_{w,j} \quad (\text{A.37})$$

where

- $N_p$  is the number of opaque components;  
 $N_w$  is the number of glazing components;  
 $\Phi_{op,j}$  is the transmission thermal load for opaque component  $j$ ;  
 $\Phi_{w,j}$  is the transmission thermal load for transparent component  $j$ .

The transmission thermal load due to opaque components is given by Equation (A.38):

$$\Phi_{op,t} = UA \left[ (\theta_{e,(t-\varphi)} - \theta_{e,m}) F_a + \theta_{e,m} \right] \quad (\text{A.38})$$

where

- $U$  is the thermal transmittance of each component;  
 $A$  is the area;  
 $\theta_{e,(t-\varphi)}$  is the external temperature at the time  $(t - \varphi)$ ;  
 $\varphi$  is the time lag;  
 $\theta_{e,m}$  is the mean daily value of the external temperature;  
 $F_a$  is the decrement factor.

The transmission thermal load due to glazing component is given by Equation (A.39):

$$\Phi_{w,t} = A \left( U \theta_{ae,t} + S_{f2} I_{sr} - \frac{U q_{lr}}{h_e} \right) \quad (\text{A.39})$$

where

- $S_{f2}$  is the secondary internal heat transfer factor;  
 $U$  is the thermal transmittance;



$I_{sr}$  is the total solar radiation impinging on the external surface;

given by:  $I_{sr} = f_s I_D + I_d + I_r$

$f_s$  is the sunlit factor due to external obstructions;

$q_{lr}$  is the heat flow rate from the external surface to the sky vault;

$h_e$  is the external heat transfer coefficient.

The external temperature is given by Equation (A.40):

— external opaque component

$$\theta_{e,t} = \theta_{ae,t} + \frac{I_{sr} S_f}{U} - \frac{q_{lr}}{h_e} \quad (\text{A.40})$$

where

$\theta_{ae}$  is the external air temperature;

$S_f$  is the solar heat gain factor;

$I_{sr}$  is the total solar radiation;

$U$  is the thermal transmittance;

$q_{lr}$  is the density of heat flow rate by radiation from the external surface to the sky vault;

$h_e$  is the external heat transfer coefficient.

The correction factors  $f_c$  and  $f_r$  are given by Equation (A.41):

$$f_c = 1 - 0,194 \left( \frac{H_T}{A_T} \right) + 0,021 \left( \frac{H_T}{A_T} \right)^2$$

$$f_r = 1 - 0,320 \left( \frac{H_T}{A_T} \right) + 0,03 \left( \frac{H_T}{A_T} \right)^2 \quad (\text{A.41})$$

where

$H_T$  is the heat transfer coefficient of the envelope defined in Equation (A.45);

$A_T$  is the total area of the envelope.

### Solar thermal load contribution

The thermal load due to the solar contribution through the glazing elements is given by Equation (A.42):

$$\Phi_{sr,t} = \left[ F_{sm} (\Phi_{er,t} - \Phi_{erm}) + \Phi_{erm} \right] \quad (\text{A.42})$$

where

$F_{sm}$  is the surface factor of the envelope;

$\Phi_{er}$  is the heat flow rate due to the solar radiation through the glazing components;

$\Phi_{erm}$  is the mean daily value of the heat flux due to the solar radiation through the glazing components.

The heat flow due to the solar radiation through the glazing components is given by Equation (A.43):

$$\Phi_{er,t} = f_t \sum_{j=1}^{N_w} (A_w I_{sr} f_{ex} S_{f1})_j \quad (\text{A.43})$$

where

$f_t$  is the frame factor;

$N_w$  is the number of glazing components;

$A_w$  is the area of each component including the frame;

$I_{sr}$  is the total solar radiation on the external surface;

$f_{ex}$  is the exposure factor;

$S_{f1}$  is the solar direct transmittance.

The frame factor  $f_t$  may be taken as 0,9.

The exposure coefficient is given in Table A.2 as a function of the exposure of the glazing.

**Table A.2 — Exposure coefficients**

	S	SW/SE	NW/NE	E/W	N
$f_{ex}$	0,81	0,92	0,92	0,97	0,87

The daily heat flow rate due to the solar radiation through the glazing components is given by Equation (A.44):

$$\Phi_{srm} = \frac{\left( \sum_{t=1}^{24} \Phi_{sr,t} \right)}{24} \quad (\text{A.44})$$

**Coefficients**  $H_T$ ,  $Y_T$ ,  $F_{sm}$

The heat transfer coefficient  $H_T$  is given by Equation (A.45):

$$H_T = \sum_{j=1}^{N_e} (U_j A_j) \quad (\text{A.45})$$

where  $N_e$  is the number of the external components.

The total admittance of the envelope is given by Equation (A.46):

$$Y_T = \sum_{j=1}^{N_e} Y_j A_j \quad (\text{A.46})$$

where

$N_e$  is the number of the external components;

$Y_j$  is the admittance of each component;

$A_j$  is the area of each component.

The admittance of the glazing components is given by Equation (A.47):

$$Y_w = \frac{1}{\frac{1}{U_w} + 0,1} \quad (\text{A.47})$$

where

$U_w$  is the thermal transmittance of the glazing component;

0,1 is a correction factor due to the internal long-wave radiative heat exchanges.

The envelope surface factor  $F_{sm}$  is given by Equation (A.48):

$$F_{sm} = \frac{\sum_{j=1}^{N_e} F_{s,j} A_j}{\sum_{j=1}^{N_e} A_j} \quad (\text{A.48})$$

#### A.3.2.2.2 Calculation of the ventilation thermal load

The ventilation thermal load at any given time is given by Equation (A.49):

$$\Phi_v = H_{ei} \theta_{ae,t} \quad (\text{A.49})$$

where  $\theta_{ae}$  is the external air temperature, in °C.

#### A.3.2.2.3 Calculation of the thermal load due to internal heat sources

The thermal load due to internal heat sources at any given time is given by Equation (A.50):

$$\Phi_{is} = \sum_{j=1}^{N_s} \Phi_{is,j} \quad (\text{A.50})$$

where

$N_s$  is the number of internal heat sources;

$\Phi_{is}$  is the heat flow rate due to each internal heat source.

#### A.3.2.2.4 Calculation of the thermal load due to the ventilation solar factor

The thermal load to the tertiary heat transfer factor  $S_{f3}$  is given by Equation (A.51):

$$\Phi_{sv} = \sum_{j=1}^{N_w} (A S_{f3} I_{sr})_j \quad (\text{A.51})$$

where

$N_w$  is the number of glazing component;

$A$  is the area of each component;

$S_{f3}$  is the solar ventilation factor;

$I_{sr}$  is the total solar radiation intensity.

#### A.3.2.3 Mean daily value of the indoor air temperature

The mean daily value of the indoor air temperature is given by Equation (A.52):

$$\theta_{am} = \frac{\sum_{t=1}^{24} \left( \frac{\Phi_{T,t}}{Y_T + c m_{a,t}} \right)}{24 - (Y_T - H_T) \sum_{t=1}^{24} \left( \frac{1}{Y_T + c m_{a,t}} \right)} \quad (\text{A.52})$$

#### A.3.3 Mean radiant temperature

The values of the mean radiant temperature, averaged over all surface components, at any given time is given by Equation (A.53):

$$\theta_{mr,t} = \frac{\left( \sum_{i=1}^N A_i \right) h_{ci} \theta_{a,t} + c m_{a,t} (\theta_{a,t} - \theta_{ae,t}) - \Phi_{is,t} - \Phi_{sv,t}}{\left( \sum_{i=1}^N A_i \right) h_{ci}} \quad (\text{A.53})$$

where

$N$  is the number of the components;

$A$  is the area of each component;

$h_{ci}$  is the convective internal heat transfer coefficient.

#### A.3.4 Operative temperature

The operative temperature at any time is given by Equation (A.54):

$$\theta_{dr,t} = \frac{\theta_{a,t} + \theta_{mr,t}}{2} \quad (\text{A.54})$$

## Annex B (informative)

### Air changes for natural ventilation

#### B.1 Introduction

This annex gives the values of the air change rate for natural ventilation. They have been determined by applying the procedure included in ISO 13791.

#### B.2 Evaluation of the air change rate for natural ventilation

##### B.2.1 General

In the following tables the number of air changes per hour are determined as a function of the open area of the window,  $S_a$ , and for the two situations:

- windows in one facade only;
- windows in two facades.

The open area factor of the window,  $S_a$ , is defined as the ratio between the effective open area of the window and the total window area.

##### B.2.2 Windows on one facade only

Table B.1 — Window opened day and night

$S_a$	0,1	0,5	0,9
Air change rate [ $h^{-1}$ ]	0,5	1,5	3

Table B.2 — Window opened during the night and closed during the day

	Day		Night	
$S_a$	0,1	0,5	0,1	0,5
Air change rate [ $h^{-1}$ ]	0,5	1,0	2,5	2,5

##### B.2.3 Windows on two facades

Table B.3 — Window opened day and night

$S_a$	0,1	0,5	0,9
Air change rate [ $h^{-1}$ ]	2,0	4,0	7,0

**Table B.4 — Window opened during the night and closed during the day**

	Day		Night	
$S_a$	0,1	0,5	0,1	0,5
<b>Air change rate [h<sup>-1</sup>]</b>	2,0	4,0	7,5	7,5

When internal curtains are present, the shaded area factor,  $S_a$ , is multiplied by 0,9 (light curtain) or 0,5 (heavy curtain).

## Annex C (informative)

### Evaluation of shaded area of a plane surface due to external obstructions

#### C.1 Introduction

This annex gives a procedure for determining the sunlit factor,  $f_s$ , of a plane surface when obstructions such as overhangs, side fins, window reveals and other buildings are present.

#### C.2 Calculation procedure

When external obstructions are present, the external surface of a wall can be partially shaded. The sunlit factor,  $f_s$ , is defined as the ratio between the sunlit area and the total area of the component. The most important obstructions are horizontal overhangs, vertical side fins, window reveals and other buildings. The simplest forms of shading element (an object causing shading) are rectilinear with the major axis either vertical or horizontal and the minor axis parallel or perpendicular to the facade. Such elements include fins, mullions, sills and reveals. Referring to Figure C.1, the vertical shaded distance,  $x_v$ , caused by a horizontal element of infinite length is given by Equation (C.1):

$$x_v = d \left( \frac{\tan \beta}{\cos \omega} \right) \quad (\text{C.1})$$

where

- $x_v$  is the vertical shaded distance;
- $d$  is the depth of the shading element;
- $\omega$  is the solar wall azimuth angle;
- $\beta$  is the solar altitude angle.

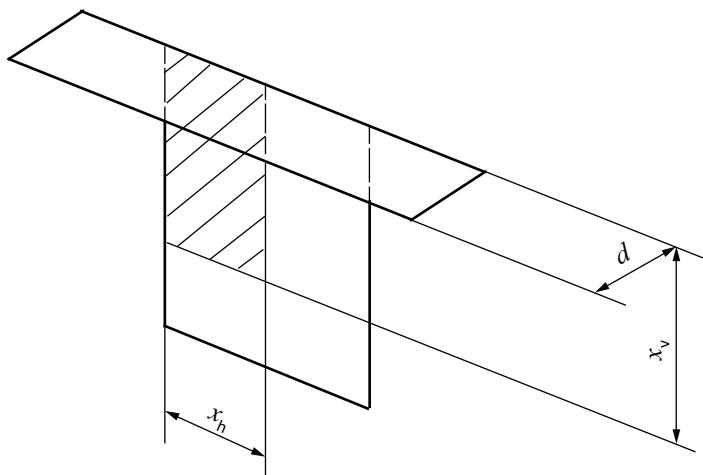

Figure C.1 — Horizontal shading

The horizontally shaded distance,  $x_h$ , is calculated in Equation (C.2) as:

$$x_h = d \tan \omega \quad (C.2)$$

The solar angles  $\beta$  and  $\omega$  depend on the solar position and they are influenced by:

- latitude of the site;
- time (hour and day);
- facade orientation and tilt.

If  $\gamma$  is the solar azimuth angle, the wall azimuth angle  $\omega$  is determined in Equation (C.3) as:

$$\omega = \gamma - \alpha \quad (C.3)$$

where  $\alpha$  is the angle between the perpendicular to the considered wall and the south direction.

Conventionally, the following assumptions are considered:

Table C.1 — The angle between the perpendicular to the considered wall and the south direction

	East	South	West	North
$\alpha$	90°	0°	-90°	180°

After having determined the  $x_h$  and  $x_v$  coordinates, the shaded area of the components are determined adopting the following assumptions:

- if both  $x_h$  and  $x_v$  are greater than the dimensions of the component it is taken as being completely shaded;
- if they are less, the shaded area is determined as in Equation (C.4):



$$A_s = w d \left( \frac{\tan \beta}{\cos \omega} \right) + h d \tan \omega - d_2 \tan \beta \left( \frac{\tan \omega}{\cos \omega} \right) \quad (\text{C.4})$$

where

$w$  is the depth of the facade;

$h$  is the height of the facade;

$d$  is the depth of the shading element.

Generally, Equation (C.4) can be considered valid when the ratio between horizontal overhang and facade length is greater than 3.

For infinite vertical side fins (Figure C.2), the shaded area is determined in Equation (C.5) as:

$$A_s = x_h d \quad (\text{C.5})$$

where  $x_h$  is determined by using Equation (C.2).

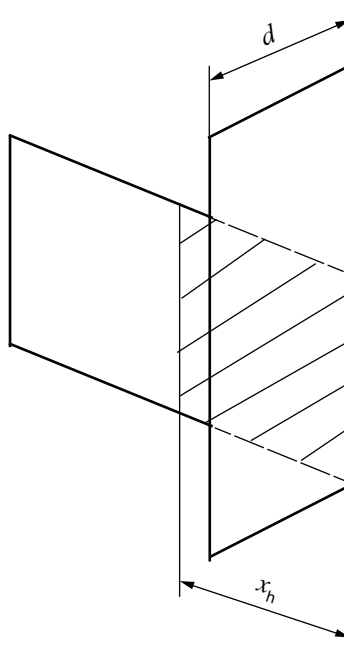

Figure C.2 — Infinite vertical side fin

## Annex D (informative)

### Internal gains

#### D.1 Introduction

This annex gives typical values of heat flow due to internal energy sources for residential and non-residential buildings.

#### D.2 Residential building

Table D.1 gives the values of the total heat flow rate due to internal sources for different rooms of residential buildings expressed in watts per floor area.

**Table D.1 — Heat flow rate per floor area (W/m<sup>2</sup>)**

Hour	Kitchen	Dining room	Bedroom
1	5	0	5
2	5	0	5
3	5	0	5
4	5	0	5
5	5	0	5
6	5	0	5
7	10	1	2
8	10	1	2
9	7	1	2
10	7	1	0
11	7	10	0
12	10	10	0
13	15	10	0
14	15	10	0
15	10	1	0
16	5	1	0
17	5	1	0
18	15	15	0
19	15	15	0
20	15	15	0
21	10	15	0
22	5	10	2
23	5	0	5
24	5	0	5

### D.3 Non-residential building

For a non-residential building the effect of the internal sources can be very important. In Table D.2 suggested values of the heat gain attributable to people, lighting and office equipment are given.

**Table D.2 — Heat gains of people, lighting and equipment in offices and restaurants**

Activity	Total heat		Sensible heat
	Met <sup>a</sup>	W/person <sup>ab</sup>	W/person <sup>a</sup>
Reclining	0,8	80	55
Seated, relaxed	1,0	100	70
Sedentary activity (office, school, laboratory)	1,2	125	75
Standing, light activity (shopping, laboratory, light industry)	1,6	170	85
Standing, medium activity (shop assistant, machine work)	2,0	210	105
Walking on the level:			
2 km/h	1,9	200	100
3 km/h	2,4	250	105
4 km/h	2,8	300	110
5 km/h	3,4	360	120
<sup>a</sup> 1 met = 58 W/m <sup>2</sup> .			
<sup>b</sup> Rounded value for a human body with a surface of 1,8 m <sup>2</sup> per person.			

## Annex E (informative)

### Examples of calculation

#### E.1 Room characteristics

Details of the window system are given in Figure E.1, while the room geometry is illustrated in Figure E.1. Thermophysical properties of the room envelope are reported in Tables E.1, E.2 and E.6. Geometric data are summarized in Figure E.2 and Table E.5. Climatic data are summarized in Table E.3. Internal heat gains are given in Table E.4. This case corresponds to the B1a test case of the validation procedure.

**Table E.1 — Double pane glazing system plus external shading —  
 Characteristics of the glazing pane and the shade**

Component	$d$ mm	$\lambda$ W/(m·K)	$\rho$ kg/m <sup>3</sup>	$c$ J/(kg·K)	$\varepsilon$	$\tau_{sr}$	$\rho_{sr}$
Pane	6	1,16	2 500	1 000	0,837	0,84	0,08
Shade	2	2,5	1 800	1 000	0,95	0,2	0,50

$\tau_{sr}$  and  $\rho_{sr}$  are the solar direct transmittance and the solar direct reflectance of each component respectively.

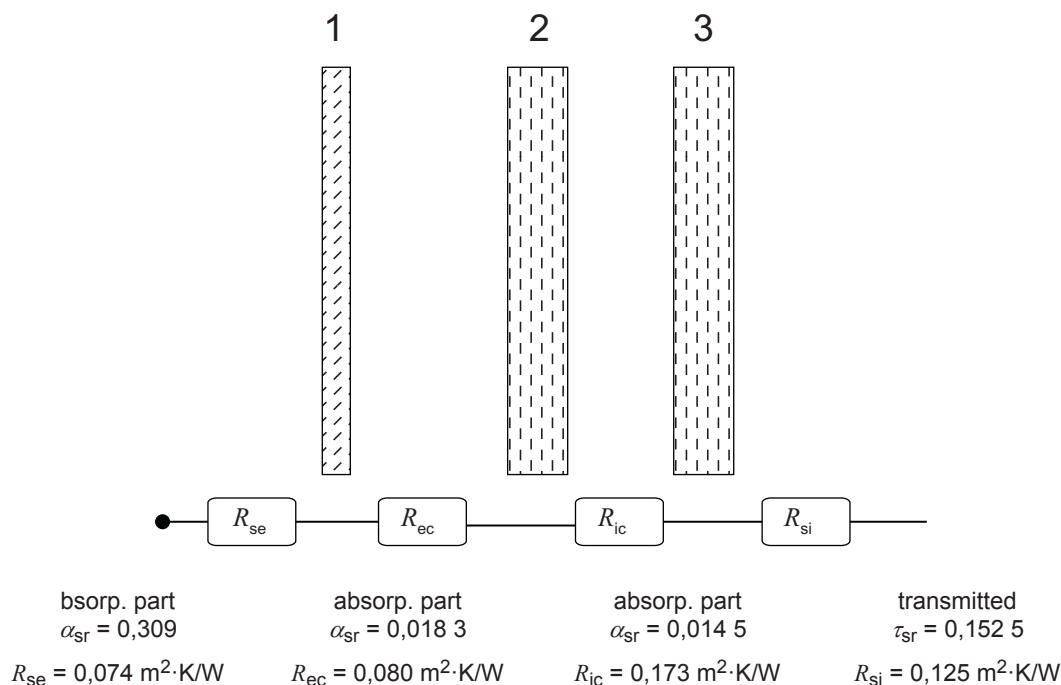

**Key**

- 1 shading device
- 2 pane 6 mm
- 3 pane 6 mm

**Figure E.1 — Double pane glazing system**

Dimensions in metres, unless otherwise specified

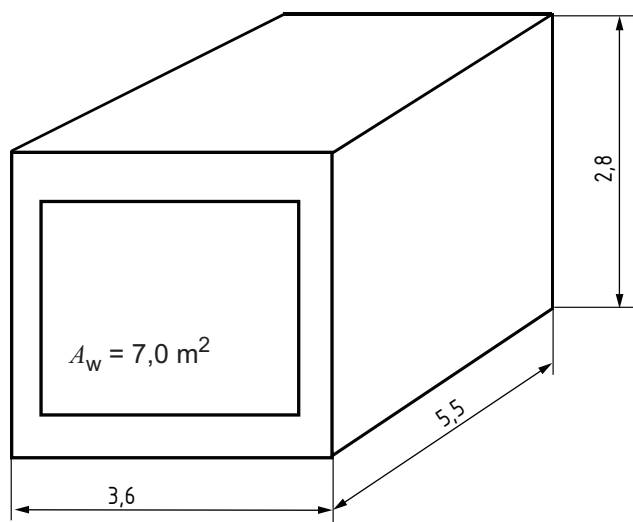

Figure E.2 — Room geometry

Table E.2 — Thermophysical properties of opaque components

	$d$ m	$\lambda$ W/(m·K)	$\rho$ kg/m <sup>3</sup>	$c$ kJ/(kg·K)
<b>Type no. 1 (external wall)</b>				
Outer layer	0,115	0,99	1 800	0,85
Insulating layer	0,06	0,04	30	0,85
Masonry	0,175	0,79	1 600	0,85
Internal plastering	0,015	0,70	1 400	0,85
<b>Type no. 2 (internal wall)</b>				
Gypsum plaster	0,012	0,21	900	0,85
Mineral wool	0,10	0,04	30	0,85
Gypsum plaster	0,012	0,21	900	0,85
<b>Type no. 3 (ceiling/ floor)</b>				
Plastic covering	0,004	0,23	500	1,5
Cement floor	0,04	1,40	2000	0,85
Mineral wool	0,10	0,04	50	0,85
Concrete	0,18	2,10	2 400	0,85
<b>Type no. 4 (ceiling/floor)</b>				
Carpet	0,006	0,08	300	1,3
Concrete	0,20	2,1	2 400	0,85
Mineral wool	0,10	0,04	50	0,85
Acoustic board	0,02	0,06	400	0,84

**Table E.3 — Climate B data (Latitude 52°N)**

Hour	$\theta_0$	$I_{TW}$	Hour	$\theta_0$	$I_{TW}$
1	14,08	0	13	26,24	366
2	13,28	0	14	27,52	558
3	12,64	0	15	28,00	703
4	12,16	0	16	27,52	778
5	12,00	22	17	26,40	756
6	12,32	55	18	24,64	604
7	13,12	80	19	22,56	271
8	14,56	101	20	21,44	0
9	16,64	117	21	18,72	0
10	10,94	128	22	17,12	0
11	21,76	135	23	15,84	0
12	24,32	150	24	14,88	0

**Table E.4 — Heat flow due to internal heat sources per floor area**

Hour	$\Phi_{ic}$ W/m <sup>2</sup>	Hour	$\Phi_{ic}$ W/m <sup>2</sup>	Hour	$\Phi_{ic}$ W/m <sup>2</sup>	Hour	$\Phi_{ic}$ W/m <sup>2</sup>
1	0	7	1	13	10	19	15
2	0	8	1	14	10	20	15
3	0	9	1	15	1	21	15
4	0	10	1	16	1	22	10
5	0	11	10	17	1	23	0
6	0	12	10	18	15	24	0

**Ventilation:**

One air change per hour

**Boundary conditions:**

External convective heat transfer coefficient:  $h_{c,e} = 8,0 \text{ W}/(\text{m}^2 \cdot \text{K})$

Internal convective heat transfer coefficient:  $h_{c,i} = 2,5 \text{ W}/(\text{m}^2 \cdot \text{K})$

Radiative heat transfer coefficient (all surfaces):  $h_{r,e} = 5,5 \text{ W}/(\text{m}^2 \cdot \text{K})$   
(valid for  $\varepsilon = 0,9$  and  $T_{mrt} = 303 \text{ K}$ )

Solar absorptance of all wall surfaces:  $\alpha_{sr} = 0,6$

**Table E.5 — Characteristics of the room elements**

Symbol	Definition	Unit
$A$	area of each component (related to the internal dimensions)	m <sup>2</sup>
$U$	thermal transmittance	W/(m <sup>2</sup> ·K)
$M$	equivalent thermal mass per area	kg/m <sup>2</sup>
$S_f$	solar heat gain factor	—
$\tau_{sr}$	solar direct transmittance	—
$S_{f2}$	secondary heat transfer factor	—
$S_{f3}$	tertiary heat transfer factor	—
$f_a$	decrement factor	—
$\varphi$	time lag	hour
$Y$	admittance	W/(m <sup>2</sup> ·K)

**Table E.6 — Geometric and thermophysical parameters**

	$A$	$U$	$M$	$S_f$	$\tau_{sr}$	$S_{f2}$	$S_{f3}$	$f_a$	$f_s$	$Y$
<b>Opaque wall</b>	3,08	0,486	141	0,021 6	0	0	0	0,11	0,28	3,25
<b>Window</b>	7,00	2,21	15	0,221	0,153	0,068	0	0,00	0,00	1,95
<b>Internal walls</b>	40,88	—	10,8	0	0	0	0	0,00	0,83	0,75
<b>Ceiling</b>	19,8	—	8	0	0	0	0	0,00	0,86	0,63
<b>Floor</b>	19,80	—	107	0	0	0	0	0,00	0,28	3,24

Volume of the room: 55,44 m<sup>3</sup>

Total area of components: 90,58 m<sup>2</sup>

## E.2 Example of calculation for the RC3 nodes model

$$A_t = 90,58 \text{ m}^2$$

$$A_w = 7 \text{ m}^2$$

The heat capacity of the structure per volume is calculated as:

$$C_m = 850 (3,08 \times 141 + 7 \times 15 + 40,88 \times 10,8 + 19,8 \times 8 + 19,8 \times 107) = 2\,769 \text{ kJ/k}$$

$A_m = 36 \text{ m}^2$  calculated according to Equation (A.12)

$$H_{ei} = 0,32 \times 1 \times 55,44 = 17,75$$

$$h_{rs} = 1,2 \times 5,6 = 6,6 \text{ W/(m}^2 \cdot \text{K)}$$

$$h_{ir} = 2,5 + 6,6 = 9,1 \text{ W/(m}^2 \cdot \text{K)}$$

$$H_{\text{ir}} = \frac{90,58}{\frac{1}{2,5} - \frac{1}{9,1}} = 312,22 \text{ W/K}$$

$$H_{\text{er}} = 7 \times 2,21 = 15,47 \text{ W/K}$$

$$H_{\text{th}} = 3,08 \times 0,486 = 1,497 \text{ W/K}$$

$$H_{\text{mr}} = 9,1 \times 36 = 327,6 \text{ W/K}$$

$$H_{\text{em}} = \frac{1}{\frac{1}{1,497} - \frac{1}{327,6}} = 1,504 \text{ W/K}$$

$$P_{\text{rs}} = 0,583 \text{ 8}$$

$$P_{\text{rm}} = 0,397 \text{ 4}$$

$$P_{\text{rsd}} = 0,548 \text{ 9}$$

$$P_{\text{rmd}} = 0,430 \text{ 7}$$

Table E.7 gives the values of the following parameters:

$\theta_{\text{es}}$  sol-air temperature of the light external components, in °C;

$\theta_{\text{em}}$  sol-air temperature of the opaque heavy components, in °C;

$\Phi_{\text{i}}$  heat flow to  $\theta_{\text{i}}$  node;

$\Phi_{\text{s}}$  heat flow to  $\theta_{\text{s}}$  node;

$\Phi_{\text{m}}$  heat flow to  $\theta_{\text{m}}$  node;

$\theta_{\text{op}}$  calculated value of the operative temperature.



Table E.7 — Values of sol-air temperatures, heat flow rate and operative temperature

From	To	$\theta_{es}$	$\theta_{em}$	$\Phi_i$	$\Phi_s$	$\Phi_m$	$\theta_{op}$
0	1	14,5	14,5	0,0	0,0	0,0	31,4
1	2	13,7	13,7	0,0	0,0	0,0	30,7
2	3	13,0	13,0	0,0	0,0	0,0	29,9
3	4	12,4	12,4	0,0	0,0	0,0	29,2
4	5	12,4	12,6	0,0	6,7	5,1	28,5
5	6	13,3	13,9	0,0	23,7	18,0	28,0
6	7	14,8	15,8	0,0	41,4	31,3	27,6
7	8	16,6	18,0	9,9	61,2	45,8	27,5
8	9	18,9	20,5	9,9	72,1	54,1	27,4
9	10	21,6	23,4	9,9	80,6	60,6	27,5
10	11	24,4	26,4	9,9	86,1	64,7	27,7
11	12	27,4	29,5	99,0	144,8	105,2	28,6
12	13	33,1	37,0	99,0	214,8	158,1	29,6
13	14	40,9	47,8	99,0	339,0	252,0	31,1
14	15	47,0	56,3	99,0	441,9	329,8	32,7
15	16	50,3	61,3	9,9	456,8	345,1	33,8
16	17	50,3	61,7	9,9	472,6	357,0	34,9
17	18	46,2	56,3	9,9	419,7	317,0	35,6
18	19	36,9	43,4	148,5	353,3	260,6	36,1
19	20	25,6	27,7	148,5	169,5	121,6	35,4
20	21	19,6	19,6	148,5	86,7	59,0	34,6
21	22	17,9	17,9	148,5	86,7	59,0	34,2
22	23	16,5	16,5	99,0	57,8	39,3	33,4
23	24	15,4	15,4	0,0	0,0	0,0	32,2

## Results

The values of the operative temperatures are:

- maximum hourly value: 36,1 °C
- mean value: 31,2 °C
- minimum hourly value: 27,4 °C

## E.3 Admittance method

Parameters required:

volume  $V = 55,44 \text{ m}^3$

total area  $A_T = 90,56 \text{ m}^2$

external area	$A_d = 10,08 \text{ m}^2$
mean transmittance	$U_m = 0,189 \text{ W}/(\text{m}^2 \cdot \text{K})$
correction factor	$f_c = 0,964$
correction factor	$f_r = 0,941$
global surface factor	$F_{sm} = 0,689$
transmittance coefficient	$H_T = 16,5 \text{ W}/\text{K}$
total admittance	$Y_T = 130,74 \text{ W}/\text{K}$

Table E.8 gives the values of the following parameters:

$\Phi_{op}$  transmission thermal load due to opaque components, in W;

$\Phi_w$  transmission thermal load due to glazing components, in W;

$\Phi_v$  thermal load due to ventilation, in W;

$\Phi_{sr}$  thermal load due to solar contribute through the glazing component, in W;

$\Phi_i$  thermal load due to internal gains, in W.

Table E.8 — Thermal load contribution

Hour	$\Phi_{op}$ W	$\Phi_w$ W	$\Phi_v$ W	$\Phi_{sr}$ W	$\Phi_i$ W
1	41,7	221,9	261,5	56,7	0
2	43,2	199,9	246,6	56,7	0
3	44,3	190,2	234,7	56,7	0
4	44,7	183,0	225,8	56,7	0
5	44,4	180,6	222,8	80,7	0
6	43,0	185,4	228,8	116,5	0
7	40,4	197,4	243,7	143,8	19,8
8	38,4	219,2	270,4	165,6	19,8
9	37,9	250,4	309,0	182,9	19,8
10	37,7	286,5	353,6	195,6	19,8
11	37,5	327,5	404,1	203,4	198
12	37,3	366,0	451,6	218,7	198
13	37,2	394,9	487,3	452,7	198
14	37,1	414,2	511,1	661,2	198
15	37,0	421,4	520,0	818,8	19,8
16	36,9	414,7	511,1	899,5	19,8
17	37,0	397,3	490,3	875,5	19,8
18	37,3	370,8	457,6	710,7	297
19	37,6	339,5	418,9	349,9	297
20	37,9	322,6	398,1	56,7	297
21	38,4	281,7	347,6	56,7	297
22	38,9	257,6	317,9	56,7	198
23	39,4	238,4	294,2	56,7	0
24	39,9	223,9	276,0	56,7	0

$$\sum_{t=1}^{24} \left( \frac{1}{Y_T + c m_t} \right) = 0,1607 \text{ m}^2 \cdot \text{K/W}$$

$$\sum_{t=1}^{24} \left( \frac{\Phi_{T,t}}{Y_T + c m_t} \right) = 172,7 \text{ m}^2 \cdot \text{K/W}$$

$$\left( \sum_{k=1}^n A_k \right) h_{ci} = 90,56 \times 2,5 = 226,4 \text{ W/K}$$

Table E.9 gives the values of the following parameters:

- $\theta_a$  air temperature;
- $\theta_{mr}$  mean radiant temperature;
- $\theta_{op}$  operative temperature.

**Table E.9 — Values of the internal temperature**

Hour	$\theta_a$ °C	$\theta_{mr}$ °C	$\theta_{op}$ °C
1	27,2	28,2	27,7
2	27,0	28,1	27,6
3	26,9	28,0	27,5
4	26,8	27,9	27,4
5	26,9	28,1	27,5
6	27,3	28,4	27,8
7	27,7	28,8	28,3
8	28,2	29,2	28,7
9	28,8	29,7	29,3
10	29,5	30,2	29,8
11	31,3	31,2	31,3
12	32,0	31,8	31,9
13	34,2	33,9	34,1
14	36,0	35,8	35,9
15	36,1	36,6	36,3
16	36,5	37,1	36,8
17	36,1	36,8	36,5
18	36,4	36,0	36,2
19	33,2	32,8	33,0
20	30,8	30,3	30,6
21	30,2	29,9	30,1
22	29,2	29,3	29,3
23	27,6	28,5	28,0
24	27,4	28,3	27,8

**Results**

The maximum, mean daily and minimum operative temperatures are:

- maximum hourly value      36,8 °C
- mean value                    31,0 °C
- minimum hourly value      27,4 °C

## Annex F (informative)

### Normative references to international publications with their corresponding European publications

This International Standard has been prepared under a mandate given to CEN by the European Commission and the European Free Trade Association (Mandate M/343), and supports essential requirements of EU Directive 2002/91/EC on the energy performance of buildings (EPBD). It forms part of a series of standards aimed at European harmonization of the methodology for the calculation of the energy performance of buildings. An overview of the whole set of standards is given in CEN/TR 15615, Explanation of the general relationship between various CEN standards and the Energy Performance of Buildings Directive (EPBD) ("Umbrella document").

The following referenced documents are indispensable for the application of this document. For dated references, only the edition cited applies. For undated references, the latest edition of the referenced document (including any amendments) applies.

Year	Publication	Title	EN	Year	Title
—	ISO 7345	Thermal insulation — Physical quantities and definitions	EN ISO 7345	—	Thermal insulation — Physical quantities and definitions
—	ISO 6946	Building components and building elements — Thermal resistance and thermal transmittance — Calculation method	EN ISO 6946	—	Building components and building elements — Thermal resistance and thermal transmittance — Calculation method
—	ISO 9050	Glass in building — Determination of light transmittance, solar direct transmittance, total solar energy transmittance, ultraviolet transmittance and related glazing factors	EN 410	—	Glass in building — Determination of luminous and solar characteristics of glazing
—	ISO 10077-1	Thermal performance of windows, doors and shutters — Calculation of thermal transmittance — Part 1: General	EN ISO 10077-1	—	Thermal performance of windows, doors and shutters — Calculation of thermal transmittance — Part 1: General
—	ISO 10292	Glass in building — Calculation of steady-state U values (thermal transmittance) of multiple glazing	EN 673	—	Glass in building — Determination of thermal transmittance (U value) — Calculation method
—	ISO 13370	Thermal performance of buildings — Heat transfer via the ground — Calculation methods	EN ISO 13370	—	Thermal performance of buildings — Heat transfer via the ground — Calculation methods

<b>Year</b>	<b>Publication</b>	<b>Title</b>	<b>EN</b>	<b>Year</b>	<b>Title</b>
—	ISO 13786	Thermal performance of building components — Dynamic thermal characteristics — Calculation methods	EN ISO 13786	—	Thermal performance of building components — Dynamic thermal characteristics — Calculation methods
—	ISO 13791	Thermal performance of buildings — Calculation of internal temperatures of a room in summer without mechanical cooling — General criteria and validation procedures	EN ISO 13791	—	Thermal performance of buildings — Calculation of internal temperatures of a room in summer without mechanical cooling — General criteria and validation procedures
—	ISO 15927-2	Hygrothermal performance of buildings — Calculation and presentation of climatic data — Part 2: Hourly data for design cooling load	EN ISO 15927-2	—	Hygrothermal performance of buildings — Calculation and presentation of climatic data — Part 2: Hourly data for design cooling load









# British Standards Institution (BSI)

BSI is the national body responsible for preparing British Standards and other standards-related publications, information and services.

BSI is incorporated by Royal Charter. British Standards and other standardization products are published by BSI Standards Limited.

## About us

We bring together business, industry, government, consumers, innovators and others to shape their combined experience and expertise into standards-based solutions.

The knowledge embodied in our standards has been carefully assembled in a dependable format and refined through our open consultation process. Organizations of all sizes and across all sectors choose standards to help them achieve their goals.

## Information on standards

We can provide you with the knowledge that your organization needs to succeed. Find out more about British Standards by visiting our website at [bsigroup.com/standards](http://bsigroup.com/standards) or contacting our Customer Services team or Knowledge Centre.

## Buying standards

You can buy and download PDF versions of BSI publications, including British and adopted European and international standards, through our website at [bsigroup.com/shop](http://bsigroup.com/shop), where hard copies can also be purchased.

If you need international and foreign standards from other Standards Development Organizations, hard copies can be ordered from our Customer Services team.

## Subscriptions

Our range of subscription services are designed to make using standards easier for you. For further information on our subscription products go to [bsigroup.com/subscriptions](http://bsigroup.com/subscriptions).

With **British Standards Online (BSOL)** you'll have instant access to over 55,000 British and adopted European and international standards from your desktop. It's available 24/7 and is refreshed daily so you'll always be up to date.

You can keep in touch with standards developments and receive substantial discounts on the purchase price of standards, both in single copy and subscription format, by becoming a **BSI Subscribing Member**.

**PLUS** is an updating service exclusive to BSI Subscribing Members. You will automatically receive the latest hard copy of your standards when they're revised or replaced.

To find out more about becoming a BSI Subscribing Member and the benefits of membership, please visit [bsigroup.com/shop](http://bsigroup.com/shop).

With a **Multi-User Network Licence (MUNL)** you are able to host standards publications on your intranet. Licences can cover as few or as many users as you wish. With updates supplied as soon as they're available, you can be sure your documentation is current. For further information, email [bsmusales@bsigroup.com](mailto:bsmusales@bsigroup.com).

## BSI Group Headquarters

389 Chiswick High Road London W4 4AL UK

## Revisions

Our British Standards and other publications are updated by amendment or revision.

We continually improve the quality of our products and services to benefit your business. If you find an inaccuracy or ambiguity within a British Standard or other BSI publication please inform the Knowledge Centre.

## Copyright

All the data, software and documentation set out in all British Standards and other BSI publications are the property of and copyrighted by BSI, or some person or entity that owns copyright in the information used (such as the international standardization bodies) and has formally licensed such information to BSI for commercial publication and use. Except as permitted under the Copyright, Designs and Patents Act 1988 no extract may be reproduced, stored in a retrieval system or transmitted in any form or by any means – electronic, photocopying, recording or otherwise – without prior written permission from BSI. Details and advice can be obtained from the Copyright & Licensing Department.

## Useful Contacts:

### Customer Services

**Tel:** +44 845 086 9001

**Email (orders):** [orders@bsigroup.com](mailto:orders@bsigroup.com)

**Email (enquiries):** [cservices@bsigroup.com](mailto:cservices@bsigroup.com)

### Subscriptions

**Tel:** +44 845 086 9001

**Email:** [subscriptions@bsigroup.com](mailto:subscriptions@bsigroup.com)

### Knowledge Centre

**Tel:** +44 20 8996 7004

**Email:** [knowledgecentre@bsigroup.com](mailto:knowledgecentre@bsigroup.com)

### Copyright & Licensing

**Tel:** +44 20 8996 7070

**Email:** [copyright@bsigroup.com](mailto:copyright@bsigroup.com)



...making excellence a habit.™