

Petroleum and natural gas industries — Design and operation of subsea production systems —

Part 6: Subsea production control systems

The European Standard EN ISO 13628-6:2006 has the status of a
British Standard

ICS 75.180.10

NO COPYING WITHOUT BSI PERMISSION EXCEPT AS PERMITTED BY COPYRIGHT LAW

National foreword

This British Standard is the official English language version of EN ISO 13628-6:2006. It is identical with ISO 13628-6:2006. It supersedes BS ISO 13628-6:2000 which is withdrawn.

The UK participation in its preparation was entrusted by Technical Committee PSE/17, Materials and equipment for petroleum, petrochemical and natural gas industries, to Subcommittee PSE/17/-/4, Drilling and production equipment, which has the responsibility to:

- aid enquirers to understand the text;
- present to the responsible international/European committee any enquiries on the interpretation, or proposals for change, and keep UK interests informed;
- monitor related international and European developments and promulgate them in the UK.

A list of organizations represented on this subcommittee can be obtained on request to its secretary.

Cross-references

The British Standards which implement international or European publications referred to in this document may be found in the *BSI Catalogue* under the section entitled “International Standards Correspondence Index”, or by using the “Search” facility of the *BSI Electronic Catalogue* or of British Standards Online.

This publication does not purport to include all the necessary provisions of a contract. Users are responsible for its correct application.

Compliance with a British Standard does not of itself confer immunity from legal obligations.

Summary of pages

This document comprises a front cover, an inside front cover, the EN ISO title page, the EN ISO foreword page, the ISO title page, pages ii to v, a blank page, pages 1 to 123 and a back cover.

The BSI copyright notice displayed in this document indicates when the document was last issued.

This British Standard was published under the authority of the Standards Policy and Strategy Committee on 31 May 2006

© BSI 2006

ISBN 0 580 48470 X

Amendments issued since publication

Amd. No.	Date	Comments

ICS 75.180.10

English Version

**Petroleum and natural gas industries - Design and operation of
subsea production systems - Part 6: Subsea production control
systems (ISO 13628-6:2006)**

Industries du pétrole et du gaz naturel - Conception et
exploitation des systèmes de production immergés - Partie
6: Commandes pour équipements immergés (ISO 13628-
6:2006)

Erdöl- und Erdgasindustrie - Auslegung und Betrieb von
Unterwasser-Fördersystemen - Teil 6: Steuersysteme für
die Unterwasser-Produktion (ISO 13628-6:2006)

This European Standard was approved by CEN on 20 April 2006.

CEN members are bound to comply with the CEN/CENELEC Internal Regulations which stipulate the conditions for giving this European Standard the status of a national standard without any alteration. Up-to-date lists and bibliographical references concerning such national standards may be obtained on application to the Central Secretariat or to any CEN member.

This European Standard exists in three official versions (English, French, German). A version in any other language made by translation under the responsibility of a CEN member into its own language and notified to the Central Secretariat has the same status as the official versions.

CEN members are the national standards bodies of Austria, Belgium, Cyprus, Czech Republic, Denmark, Estonia, Finland, France, Germany, Greece, Hungary, Iceland, Ireland, Italy, Latvia, Lithuania, Luxembourg, Malta, Netherlands, Norway, Poland, Portugal, Romania, Slovakia, Slovenia, Spain, Sweden, Switzerland and United Kingdom.



EUROPEAN COMMITTEE FOR STANDARDIZATION
COMITÉ EUROPÉEN DE NORMALISATION
EUROPÄISCHES KOMITEE FÜR NORMUNG

Management Centre: rue de Stassart, 36 B-1050 Brussels

EN ISO 13628-6:2006

Foreword

This document (EN ISO 13628-6:2006) has been prepared by Technical Committee ISO/TC 67 "Materials, equipment and offshore structures for petroleum and natural gas industries" in collaboration with Technical Committee CEN/TC 12 "Materials, equipment and offshore structures for petroleum, petrochemical and natural gas industries", the secretariat of which is held by AFNOR.

This European Standard shall be given the status of a national standard, either by publication of an identical text or by endorsement, at the latest by November 2006, and conflicting national standards shall be withdrawn at the latest by November 2006.

According to the CEN/CENELEC Internal Regulations, the national standards organizations of the following countries are bound to implement this European Standard: Austria, Belgium, Cyprus, Czech Republic, Denmark, Estonia, Finland, France, Germany, Greece, Hungary, Iceland, Ireland, Italy, Latvia, Lithuania, Luxembourg, Malta, Netherlands, Norway, Poland, Portugal, Romania, Slovakia, Slovenia, Spain, Sweden, Switzerland and United Kingdom.

Endorsement notice

The text of ISO 13628-6:2006 has been approved by CEN as EN ISO 13628-6:2006 without any modifications.

INTERNATIONAL
STANDARD

ISO
13628-6

Second edition
2006-05-15

**Petroleum and natural gas industries —
Design and operation of subsea
production systems —**

**Part 6:
Subsea production control systems**

*Industries du pétrole et du gaz naturel — Conception et exploitation des
systèmes de production immergés —*

Partie 6: Commandes pour équipements immergés



Reference number
ISO 13628-6:2006(E)

Contents

Page

Foreword.....	v
1 Scope	1
2 Normative references	2
3 Terms and definitions	3
4 Abbreviated terms	6
5 System requirements	8
5.1 General	8
5.2 Concept development	8
5.3 Production control system functionality requirement	8
5.4 General requirements	10
5.5 Functional requirements	17
5.6 Design requirements	21
6 Surface equipment	25
6.1 General	25
6.2 General requirements	26
6.3 Functional requirements	26
6.4 Design requirements	26
7 Subsea equipment	34
7.1 General	34
7.2 General requirements	34
7.3 Functional requirements	34
7.4 Design requirements	34
8 Interfaces	44
8.1 General	44
8.2 Interface to host facility	44
8.3 Interface to subsea equipment	45
8.4 Interface to workover control system	46
8.5 Interface to intelligent wells	46
9 Materials and fabrication	50
9.1 General	50
9.2 Materials	50
9.3 Fabrication	51
10 Quality	52
11 Testing	52
11.1 General	52
11.2 Qualification testing	52
11.3 Factory acceptance tests (FAT)	56
11.4 Integrated system tests	59
11.5 Documentation	60
12 Marking, packaging, storage and shipping	60
12.1 Marking	60
12.2 Packaging	60
12.3 Storage and shipping	61
Annex A (informative) Types and selection of control system	63
Annex B (informative) Typical control and monitoring functions	66

EN ISO 13628-6:2006

Annex C (informative) Properties and testing of control fluids	68
Annex D (informative) Operational considerations with respect to flowline pressure exposure	96
Annex E (normative) Interface to intelligent well	98
Annex F (informative) Definition of subsea electromagnetic environment and guidance on the selection of tests, limits and severity to provide a presumption of compliance of subsea equipment	104
Bibliography	121

Foreword

ISO (the International Organization for Standardization) is a worldwide federation of national standards bodies (ISO member bodies). The work of preparing International Standards is normally carried out through ISO technical committees. Each member body interested in a subject for which a technical committee has been established has the right to be represented on that committee. International organizations, governmental and non-governmental, in liaison with ISO, also take part in the work. ISO collaborates closely with the International Electrotechnical Commission (IEC) on all matters of electrotechnical standardization.

International Standards are drafted in accordance with the rules given in the ISO/IEC Directives, Part 2.

The main task of technical committees is to prepare International Standards. Draft International Standards adopted by the technical committees are circulated to the member bodies for voting. Publication as an International Standard requires approval by at least 75 % of the member bodies casting a vote.

Attention is drawn to the possibility that some of the elements of this document may be the subject of patent rights. ISO shall not be held responsible for identifying any or all such patent rights.

ISO 13628-6 was prepared by Technical Committee ISO/TC 67, *Materials, equipment and offshore structures for petroleum and natural gas industries*, Subcommittee SC 4, *Drilling and production equipment*.

This second edition cancels and replaces the first edition (ISO 13628-6:2000) which has been technically revised.

ISO 13628 consists of the following parts, under the general title *Petroleum and natural gas industries — Design and operation of subsea production systems*:

- *Part 1: General requirements and recommendations*
- *Part 2: Unbonded flexible pipe systems for subsea and marine applications*
- *Part 3: Through flowline (TFL) systems*
- *Part 4: Subsea wellhead and tree equipment*
- *Part 5: Subsea umbilicals*
- *Part 6: Subsea production control systems*
- *Part 7: Completion/workover riser systems*
- *Part 8: Remotely Operated Vehicle (ROV) interfaces on subsea production systems*
- *Part 9: Remotely Operated Tools (ROT) intervention systems*
- *Part 10: Specification for bonded flexible pipe*
- *Part 11: Flexible pipe systems for subsea and marine applications*

Part 12 on dynamic production risers is in preparation.



blank

Petroleum and natural gas industries — Design and operation of subsea production systems —

Part 6: Subsea production control systems

1 Scope

This part of ISO 13628 is applicable to design, fabrication, testing, installation and operation of subsea production control systems.

This part of ISO 13628 covers surface control system equipment, subsea-installed control system equipment and control fluids. This equipment is utilized for control of subsea production of oil and gas and for subsea water and gas injection services. Where applicable, this part of ISO 13628 can be used for equipment on multiple-well applications.

This part of ISO 13628 establishes design standards for systems, subsystems, components and operating fluids in order to provide for the safe and functional control of subsea production equipment.

This part of ISO 13628 contains various types of information related to subsea production control systems. They are

- informative data that provide an overview of the architecture and general functionality of control systems for the purpose of introduction and information;
- basic prescriptive data that shall be adhered to by all types of control system;
- selective prescriptive data that are control-system-type sensitive and shall be adhered to only when they are relevant;
- optional data or requirements that need be adopted only when considered necessary either by the purchaser or the vendor.

In view of the diverse nature of the data provided, control system purchasers and specifiers are advised to select from this part of ISO 13628 only the provisions needed for the application at hand. Failure to adopt a selective approach to the provisions contained herein can lead to overspecification and higher purchase costs.

Rework and repair of used equipment are beyond the scope of this part of ISO 13628.

2 Normative references

The following referenced documents are indispensable for the application of this document. For dated references, only the edition cited applies. For undated references, the latest edition of the referenced document (including any amendments) applies.

ISO 3722, *Hydraulic fluid power — Fluid sample containers — Qualifying and controlling cleaning methods*

ISO 4406:1999 *Hydraulic fluid power — Fluids — Method for coding the level of contamination by solid particles*

ISO 7498 (all parts), *Information processing systems — Open Systems Interconnection — Basic Reference Model*

ISO 9606-1, *Approval testing of welders — Fusion welding — Part 1: Steels*

ISO 9606-2, *Qualification test of welders — Fusion welding — Part 2: Aluminium and aluminium alloys*

ISO 10423, *Petroleum and natural gas industries — Drilling and production equipment — Wellhead and christmas tree equipment*

ISO 10945, *Hydraulic fluid power — Gas-loaded accumulators — Dimensions of gas ports*

ISO/TR 10949, *Hydraulic fluid power — Component cleanliness — Guidelines for achieving and controlling cleanliness of components from manufacture to installation*

ISO 13628-4, *Petroleum and natural gas industries — Design and operation of subsea production systems — Part 4: Subsea wellhead and tree equipment*

ISO 13628-5, *Petroleum and natural gas industries — Design and operation of subsea production systems — Part 5: Subsea umbilicals*

ISO 15607, *Specification and qualification of welding procedures for metallic materials — General rules*

ISO 15609-2, *Specification and qualification of welding procedures for metallic materials — Welding procedure specification — Part 2: Gas welding*

ISO 15610, *Specification and qualification of welding procedures for metallic materials — Qualification based on tested welding consumables*

ISO 15611, *Specification and qualification of welding procedures for metallic materials — Qualification based on previous welding experience*

ISO 15612, *Specification and qualification of welding procedures for metallic materials — Qualification by adoption of a standard welding procedure*

ISO 15613, *Specification and qualification of welding procedures for metallic materials — Qualification based on pre-production welding test*

ISO 15614-1, *Specification and qualification of welding procedures for metallic materials — Welding procedure test — Part 1: Arc and gas welding of steels and arc welding of nickel and nickel alloys*

ISO/TS 16431, *Hydraulic fluid power — Assembled systems — Verification of cleanliness*

ANSI/ASME B31.3, *Process Piping*

ASME Boiler and Pressure Vessel Code, Section VIII, Division 1, *Rules for the Construction of Pressure Vessels*

ASME Boiler and Pressure Vessel Code, Section IX, *Welding and Brazing Qualifications*

ASTM D97, *Standard Method for Pour Point of Petroleum Products*

ASTM D445, *Standard Test Method for Kinematic Viscosity of Transparent and Opaque Liquids (and the Calculation of Dynamic Viscosity)*

ASTM D471, *Standard Test Method for Rubber Property — Effect of Liquids*

ASTM D665:2003, *Standard Test Method for Rust Preventing Characteristics of Inhibited Mineral Oil in the Presence of Water*

ASTM D892, *Standard Test Method for Foaming Characteristics of Lubricating Oils*

ASTM D1141, *Standard Practice for the Preparation of Substitute Ocean Water*

ASTM D1298, *Standard Test Method for Density, Relative Density (Specific Gravity), or API Gravity of Crude Petroleum and Liquid Petroleum Products by Hydrometer Method*

ASTM D2625, *Standard Test Method for Endurance (Wear) Life and Load-Carrying Capacity of Solid Film Lubricants (Falex Pin and Vee Method)*

ASTM D2670, *Standard Test Method for Measuring Wear Properties of Fluid Lubricants (Falex Pin and Vee Block Method)*

ASTM D3233, *Standard Test Methods for Measurement of Extreme Pressure Properties of Fluid Lubricants (Falex Pin and Vee Block Methods)*

ASTM G1:2003, *Standard Practice for Preparing, Cleaning, and Evaluating Corrosion Test Specimens*

BS 7201-1, *Hydraulic fluid power — Gas loaded accumulators — Specification for seamless steel accumulator bodies above 0,5 l water capacity*

DIN 41612-2, *Special contacts for multi two-part connectors; concentric contacts (type C)*

IEC 61892 (all parts), *Electrical installations of ships and of mobile and fixed offshore units*

Internet RFC 791, *Internet Protocol*, <http://www.faqs.org/rfcs/rfc791.html>

Internet RFC 793, *The Transmission Control Protocol (TCP)*, <http://www.faqs.org/rfcs/rfc793.html>

Internet RFC 1332, *The PPP Internet Protocol Control Protocol (IPCP)*, <http://www.ietf.org/rfc/rfc1332.txt>

Internet RFC 1661, *The Point-to-Point Protocol (PPP)*, <http://www.faqs.org/rfcs/rfc1661.html>

IP 34, *Determination of flash point Pensky-Martens closed cup method*

IP 135:2005, *Determination of rust-preventing characteristics of steam-turbine oil in the presence of water*

3 Terms and definitions

For the purposes of this document, the following terms and definitions apply.

3.1

boost

pressure maintained on the spring-return side of a subsea actuator for the purposes of improving closing-time response

3.2

commanded closure

closure of the underwater safety valve and possibly other valves depending on the control system design

NOTE Such commands can originate manually, automatically or as part of an ESD.

3.3

control path

total distance that a control signal (e.g. electrical, optical, hydraulic) travels from the topside control system to the subsea control module or valve actuator

3.4

design pressure

maximum pressure for which the system or component was designed for continuous usage

3.5

design life

specified operational life of system after pre-delivery test

3.6

diagnostic data

data provided to monitor the condition of the downhole equipment

NOTE Can include the ability to make (engineering) adjustments.

3.7

direct hydraulic control

control method wherein hydraulic pressure is applied through an umbilical line to act directly on a subsea valve actuator

NOTE Upon venting of the pressure at the surface, the control fluid is returned through the umbilical to the surface due to the action of the restoring spring in the valve actuator. Subsea functions may be ganged together to reduce the number of umbilical lines.

3.8

downstream

away from a component in the direction of flow

3.9

electrohydraulic control

control method wherein communication signals are conducted to the subsea system and used to open or close electrically-controlled hydraulic control valves

NOTE Hydraulic fluid is locally sourced and acts on the associated subsea valve actuator. "Locally sourced" may mean locally stored pressurized fluid or fluid supplied by a hydraulic umbilical line. With electrohydraulic control systems, data telemetry (readback) is readily available at high speed. Multiplexing of the communication signals reduces the number of conductors in the umbilical.

3.10

expert operation

operating the IWCS with other control commands or other methods than used for normal operation

NOTE Typically used by IWCS supplier or other skilled resource to read IWCS diagnostic data and make (engineering) adjustments to IWCS equipment.

3.11

hydrostatic test pressure

maximum test pressure at a level greater than the design pressure (rated working pressure)

3.12**intelligent well**

well that employs permanently installed downhole sensors and/or permanently installed downhole control devices that are operable from a surface facility

3.13**intelligent well control system**

control system used to operate an intelligent well

3.14**normal operation**

operating the system to perform the intended basic functionality

3.15**offset**

horizontal component of control path length

3.16**proof pressure**

maximum test pressure at a level greater than the design pressure

3.17**response time**

sum of the signal time and the shift time

3.18**running tool**

tool used to install, operate, retrieve, position or connect subsea equipment remotely from the surface

NOTE An example is the subsea control-module running tool.

3.19**shift time**

period of time elapsed between the arrival of a control signal at the subsea location (the completion of the signal time) and the completion of the control function operation

NOTE Of primary interest is the time to fully stroke, on a subsea tree, a master or wing valve that has been designated as the underwater safety valve.

3.20**signal time**

period of time elapsed between the remote initiation of a control command and the initiation of a control function operation subsea (the commencement of the shift time)

3.21**subsea production control system**

control system operating a subsea production system during production operations

3.22**surface safety valve**

safety device that is located in the production bore of the well tubing above the wellhead (platform well), or at the point of subsea well production embarkation onto a platform, and that will automatically close upon loss of hydraulic pressure

3.23**umbilical**

combination of electric cables, hoses or steel tubes, either on their own or in combination (or with fibre optic cables), cabled together for flexibility and over-sheathed and/or armoured for mechanical strength and typically supplying power and hydraulics, communication and chemicals to a subsea system

3.24

underwater safety valve

safety valve assembly that is declared to be the USV and which will automatically close upon loss of power to that actuator

3.25

upstream

away from a component against the direction of flow

3.26

well data

data provided from the downhole equipment for reservoir description, flow calculations and routine production monitoring

NOTE Typically, these include sensor readings and valve positions.

3.27

β

filtration ratio

4 Abbreviated terms

ANSI	American National Standards Institute
AC	alternating current
API	American Petroleum Institute
AS	Aerospace Standard
ASME	American Society of Mechanical Engineers
ASTM	American Society for Testing and Materials
AWS	American Welding Society
BER	bit error rate
capex	capital expenditure
CB	centre of buoyancy
CISPR	Comité International Spécial des Perturbations Radioélectrique (International Special Committee on Radio-Interference)
CIU	chemical injection unit
CIV	chemical injection valve
CPS	combined power and signal
CW	clockwise
DC	direct current
DCS	distributed control system
DCV	directional control valve
DH	direct hydraulic
EPU	electrical power unit
EM	electromagnetic
EMC	electromagnetic compatibility
ESD	emergency shutdown
ESS	environmental stress screening
ETH	ethernet
EUT	equipment under test

EXT	extended
FAT	factory acceptance test
GND	ground
HF	high frequency
HIPPS	high integrity pipeline protection system
HP	high pressure
HPU	hydraulic power unit
HRC	hardness Rockwell C
HV	high voltage
IEC	International Electrotechnical Commission
I/O	input/output
IP	Institute of Petroleum
iSEM	intelligent well subsea electronics module
ISM	industrial, scientific and medical
ITE	information technology equipment
IWCS	intelligent well control system
IWE	intelligent well equipment
LF	low frequency
LP	low pressure
MCS	master control station
MIL-STD	Military Standard
mo	month
MV	manifold valve
OPC	object linking and embedding (OLE) for process control
Opex	operational expenditure
OREDA	offshore reliability data
OSI	open system interconnection
PH	piloted hydraulic
PMV	production master valve
PSD	process shutdown
PTFE	polytetrafluoroethylene
PWV	production wing valve
RET	return
RMS	root mean square
ROV	remotely operated vehicle
RPC	remote procedure call
RX	radio receiver
SCM	subsea control module
SCSSV	surface-controlled subsurface safety valve
SEM	subsea electronic module
TAN	total acid number
TBD	to be decided
TBN	total base number
TCP	transmission control protocol

THD	total harmonic distortion
TX	radio transmitter
UPS	uninterruptible power supply
USV	underwater safety valve
VAC	volts alternating current
VDC	volts direct current
wk	week
yr	year

5 System requirements

5.1 General

In 5.2 to 5.6 are described the activities of specifying organisations. Reference should be made to Annex A for types and selection of control system, and to Annex B for typical control and monitoring functions.

5.2 Concept development

During front-end engineering, possible impact on control system functionality and infrastructure related to the following items shall be considered:

- flexibility with respect to production scenarios;
- optimization with respect to operation;
- optimization with respect to cost-effective installation;
- optimization with respect to phased production development;
- flow assurance;
- project execution time;
- life cycle cost [component cost (capex), installation cost (opex), operation/maintenance/intervention cost (opex)].

Operational philosophy, installation sequences and possible operational challenges shall be evaluated during front-end engineering.

Reference should be made to Annex D for operational considerations with respect to flowline pressure exposure.

5.3 Production control system functionality requirement

5.3.1 General

The subsea production control system shall allow for flexibility and optimization. The basic system design shall to a maximum extent allow for a full range of functionality with use of existing infrastructure.

The following elements shall be considered during system engineering:

- intelligent well application;
- flexibility with respect to electrical load situations (power and communication);
- robustness of hydraulic system;
- prevention of seawater ingress in hydraulic system;

- seawater ingress material compatibility;
- subsea intervention;
- increased scope with respect to number of wells;
- increased scope with respect to number of umbilicals;
- increased scope with respect to control/instrumentation functionality;
- interface toward subsea separation/subsea boosting systems;
- subsea chemical injection;
- downhole instrumentation system interfaces;
- downhole chemical injection.

5.3.2 Intelligent well application

If an intelligent well completion is clearly defined as a current or future requirement by front-end engineering efforts, the control system will provide valve functionality, data retrieval, computational support and communication pathways without the need for changing the subsea umbilical system and the associated distribution system. Subsea control modules may be expected to be retrieved and retrofitted to accommodate the introduction of smart well systems at a future date.

Automatic shutdown functionality is not required for the downhole intelligent well functions.

5.3.3 Flexibility with respect to electrical load situations (power and communication)

The system should be built to function properly within a large range of electrical load variations to allow for flexibility regarding new wells. Load flexibility can help overcome electrical distribution system failures by connecting more wells to the same cable.

5.3.4 Robustness of hydraulic system

The hydraulic system shall be robust and maintain acceptable pressure values in the SCM during all modes of operation.

Actuation of valve actuators shall not cause alarms or unintended valve movement due to low supply pressure in the SCM. The pressure should not drop below 150 % of the highest latching pressure of any DCV.

5.3.5 Seawater ingress in hydraulic system

The hydraulic system shall be designed to minimize seawater ingress in all operational scenarios, including installation and retrieval of individual units. If seawater ingress prevention cannot be guaranteed or if there is a credible risk of seawater ingress, SCM fluid-wetted components should be considered along with procedures to flush out contaminated fluid.

5.3.6 Subsea intervention

The subsea control system shall be designed for cost-effective subsea intervention tasks, with respect to both ROV and diver applications.

5.3.7 Increased scope with respect to number of wells

The system shall allow for flexibility with respect to number of wells tied into the system. Operational and criticality analysis should represent the practical limitations with respect to number of wells rather than mechanical limitations.

5.3.8 Increased scope with respect to number of umbilicals

System design, when defined as a future requirement by front-end engineering, shall allow for additional umbilical systems to be connected. A philosophy covering both serial and parallel connections should be outlined.

5.3.9 Interface toward subsea separation/subsea boosting system

The system design when defined as a future requirement by front-end engineering shall allow for possible connection of a subsea separation or boosting system without extensive marine operations or modifications related to an existing system. Possible impact on production control system shall be described at an outline level during system design.

5.3.10 Subsea chemical injection

Flow-assurance issues shall be considered during front-end engineering. The system shall allow for flexibility with respect to possible chemical injection scenarios during the operational phase. This flexibility can be achieved by including spare lines in the subsea distribution system, plan for possible subsea chemical injection system add on, reconfiguration of lines, etc. Possible impact on production control system shall be described at an outline level during system design.

5.3.11 Downhole instrumentation system interfaces

The production control system shall allow for flexibility regarding interface toward downhole instrumentation systems. Possible impact on production control system shall be described at an outline level during system design.

5.3.12 Downhole chemical injection

The subsea production system shall, if applicable, allow for downhole chemical injection. Possible impact on production control system shall be described at an outline level during system design.

5.4 General requirements

5.4.1 General

The functional building blocks of a subsea production control system typically include the following. These building blocks may be integrated in the same physical units:

a) hydraulic power unit (HPU):

The HPU provides a stable and clean supply of hydraulic fluid to the remotely operated subsea valves. The fluid is supplied via the controls' umbilical, the subsea hydraulic distribution system, and the SCMs (if included in system design) to operate subsea valve actuators.

b) chemical injection unit (CIU):

The CIU provides single and/or mixed "cocktail" chemicals at constant regulated pressure or metered volume. The fluid is supplied via the hydraulic umbilical and the subsea hydraulic distribution system to the injection points of the subsea production system.

c) master control station (MCS):

The MCS may be the central control "node" containing application software required to control and monitor the subsea production system and associated topside equipment such as the HPU and EPU.

d) distributed control system (DCS):

The DCS can perform the same functions as an MCS, but with a decentralized configuration.

e) electrical power unit (EPU):

The EPU supplies electrical power at the desired voltage and frequency to the subsea users. Power transmission is performed via the electrical umbilical and the subsea electrical distribution system.

f) modem unit:

This unit modulates and demodulates communication signals for transmission to and from the applicable subsea users.

g) uninterruptible power supply (UPS):

The UPS is typically provided to ensure safe and reliable electrical power to the subsea production control system.

h) umbilical:

The umbilical(s) transfer(s), as required, electrical power and communication signals, hydraulic power, and/or chemicals to the subsea components of the subsea production system. Communication signals may be transmitted via power cable (signal on power), signal cable or fibre optic.

i) subsea control module (SCM):

In a piloted-hydraulic, electrohydraulic or electric control system, the SCM is the unit that, upon command from the MCS, directs hydraulic fluid to operate subsea valves. In an electrohydraulic or electric system, the SCM also gathers information from the subsea control system equipment and transmits the information to the topside facility.

j) subsea distribution systems:

Distribution systems distribute electrical, hydraulic and chemical supplies and electrical/optical communications signals from the umbilical termination(s) to the subsea trees, manifold valves, injection points, and the control modules of the subsea production control system.

k) subsea and downhole sensors:

Sensors located in the SCMs, on subsea trees or manifolds, on the seabed or downhole provide data to help monitor operation of the subsea production system.

l) control fluids:

Oil- or water-glycol based liquids are used to transmit, control and distribute hydraulic signals and energy from the surface HPU to the subsea control system.

m) control buoy:

Moored-buoy-housing generation, communication and chemical injection (optional) equipment is connected to the subsea components of the subsea production system via an electrical/fibre optic/hydraulic control umbilical. The buoy can communicate with the surface production facility via umbilical, acoustic, radio or satellite links or a combination thereof.

n) flying lead:

Flying lead(s) transfer(s) electrical power and communications signals, hydraulic power, and/or chemicals to the subsea components of the subsea production system. Signals may be transmitted via combined signal and power cable, separate signal and power cable, or separate fibre optic signal and power cable.

This part of ISO 13628 covers all systems, both hydraulic and electrohydraulic. Only the relevant subclauses should be used.

5.4.2 Service condition

5.4.2.1 Suitability for working environment

The subsea control system shall be designed and operated with consideration for the external environment. For surface facilities, this includes climatic conditions, corrosion, marine growth, tidal forces, illumination and hazardous-area classifications. For the subsea environment, this includes corrosion, ambient pressure and temperature, marine growth and fouling, fishing activity or marine operations, currents, seafloor composition and maintenance considerations. Suitability to the likely storage environment should be considered. This can include ultra-violet radiation, ozone, ice, sand, wind, humidity or temperature extremes.

Product designs shall be capable of withstanding design pressure at rated temperature without degradation, exceeding allowable stress levels, or impairment of other performance requirements for the design life of the system.

5.4.2.2 Pressure ratings

5.4.2.2.1 General

Specialized conditions shall also be considered, such as pressure rating changes in system and component interfaces (such as subsea control module to receiver plate, umbilical to tree-mounted terminations) and pressurizing with temporary plugs and caps installed. The effects of external loads (i.e. bending moments, tension), ambient hydrostatic loads and fatigue shall be considered.

In order to preserve the existing installed base of designed, qualified and field-proven systems and equipment with a safe field-operations history, such systems and equipment should be exempted from the working- and design-pressure rating subclauses in this part of ISO 13628, and accepted for use within projects/systems specifying compliance with this edition of this part of ISO 13628. Where applicable to the preceding, exceptions to this part of ISO 13628 shall be identified early in the development process and addressed on a case-by-case basis.

The maximum working pressure of the system shall not exceed the design pressure of the components that are used to build the system.

Provisions shall be made to include a system pressure-relieving device, normally a system pressure relief valve, to ensure that surge pressures in the system do not exceed the design pressure of the system components by more than 10 %.

When setting the system pressure-controlling device, normally a pressure regulator, a minimum of 5 % of the design pressure shall be left as a margin between the maximum working pressure of the system (as set by the system pressure-controlling device) and the reseal pressure of the system pressure-relieving device. This is to prevent overlapping of the two pressures with excessive pump operation as a result.

Proof pressure shall be a minimum of 1,5 times design pressure.

5.4.2.2.2 Hydraulic control components

It is recommended that hydraulic components have design pressures according to Table 1. Hydraulic components for the SCSSV circuit shall have a design pressure in accordance with the design pressures of the SCSSV.

Table 1 — Pressure relations

Recommended design-pressure classes	Minimum proof pressure
MPa (psi)	MPa (psi)
11,3 (1 639)	17,0 (2 465)
22,8 (3 307)	34,2 (4 960)
37,9 (5 497)	56,9 (8 252)
56,9 (8 252)	85,3 (12 372)
75,9 (11 000)	113,8 (16 520)
113,9 (16 520)	170,8 (24 772)

5.4.2.2.3 Other equipment

The design pressure of other equipment such as running, retrieval and test tools shall comply with manufacturer's written specifications.

5.4.2.3 Temperature ratings (host facility equipment)

5.4.2.3.1 Without controlled environment

Surface-installed equipment covered by this part of ISO 13628 and not installed in a controlled environment shall be designed, tested, operated and stored in accordance with the temperature ratings listed in Table 2.

Table 2 — Temperature rating — Surface-installed equipment without controlled environment

	Electronics		System	
	°C	(°F)	°C	(°F)
Design				
a) Standard	0 to 40	(32 to 104)	0 to 40	(32 to 104)
b) Extended	– 18 to 70	(0 to 158)	– 18 to 40	(0 to 104)
Operate				
a) Standard	0 to 40	(32 to 104)	0 to 40	(32 to 104)
b) Extended	– 5 to 40	(23 to 104)	– 5 to 40	(23 to 104)
Store	– 18 to 50	(0 to 122)	– 18 to 50	(0 to 122)
Temperatures relate to environment, not individual components.				

Equipment shall be marked in accordance with 12.1.2.

5.4.2.3.2 Controlled environment

Surface-installed equipment covered by this part of ISO 13628, and installed in a controlled environment, shall be designed, tested, operated and stored in accordance with temperature ratings compatible with the specified controlled environment.

Packaged assemblies or components that are restricted for use in a controlled environment shall be appropriately marked in accordance with the provision of 12.1.3.

5.4.2.4 Temperature ratings (subsea-installed equipment)

Subsea-installed equipment covered by this part of ISO 13628 shall be designed, tested, operated and stored in accordance with the temperature ratings listed in Table 3.

Table 3 — Temperature rating — Subsea-installed equipment

	Electronics		System	
	°C	(°F)	°C	(°F)
Design				
a) Standard	– 10 to 70	(14 to 158)	0 to 40	(32 to 104)
b) Extended	– 18 to 70	(0 to 158)	– 18 to 40	(0 to 104)
Test				
a) Standard	– 10 to 40	(14 to 104)	0 to 40	(32 to 104)
b) Extended	– 18 to 40	(0 to 104)	– 18 to 40	(0 to 104)
Operate				
a) Standard	0 to 40	(32 to 104)	0 to 40	(32 to 104)
b) Extended	– 5 to 40	(23 to 104)	– 5 to 40	(23 to 104)
Store	– 18 to 50	(0 to 122)	– 18 to 50	(0 to 122)

Temperatures in Table 3 relate to environment, not individual components. Subsea sensors that monitor produced or injected fluid may operate outside the ranges given. They shall be rated accordingly.

Equipment shall be marked in accordance with 12.1.2.

5.4.2.5 Electromagnetic compatibility

The design shall conform to the applicable local regulations regarding EMC for the environment in which the equipment is used. For EMC, surface equipment comes within the scope of IEC 61892 (all relevant parts) which cites IEC 60533^[22]. For subsea equipment, each application needs to be considered with regard to its installed environment but guidance should be taken from the appropriate sections of IEC 61000-2^[27]. Annex F of this part of ISO 13628 gives definitions for a subsea environment and guidance on the selection of tests, limits and severity levels that can be used in order to provide a presumption of compliance. Consideration should also be given to IEC 61000-1-2^[28], particularly for HIPPS.

5.4.2.6 Storage/test temperature recommendations

If subsea-installed or surface-installed equipment is to be stored or tested on the surface at a temperature outside its temperature rating, then the manufacturer should be contacted to determine if special storage or surface testing procedures are recommended. Manufacturers shall document any such special storage or surface testing considerations, such as exposure to fluctuations in ultra violet, ozone, ice sand, wind, humidity, or temperature extremes.

5.4.2.7 External hydrostatic pressure

In subsea applications, external hydrostatic pressure can be higher than internal system pressure. This external loading situation shall be considered, especially relative to seal design, self-sealing couplings and one-atmosphere enclosures. Umbilical and distribution flying-lead collapse during installation and in service shall also be considered.

5.4.2.8 Fluid compatibility

Components shall be selected considering compatibility with both control fluid and chemical injection fluid. In addition, compatibility with process fluid, cleaners, preservers, seawater, brines, diesel and corrosion inhibitors shall be considered.

5.4.3 Hydraulic system

5.4.3.1 Hydraulic control fluid

Selection of hydraulic control fluid shall consider the maximum temperature and pressure to which the hydraulic fluid can be exposed in the well. The driver for the maximum fluid temperature is likely to be the flowing temperature at the SCSSV. All parts and components in the system shall be compatible with the selected fluid. Reference should be made to Annex C.

The handling and topside safety and environmental implications should be considered carefully in the selection of the control fluid and control fluid distribution system.

5.4.3.2 Cleanliness

The hydraulic fluid-wetted portion of the control system shall be prepared to a cleanliness level as defined in AS 4059^[51]. The selected cleanliness level shall be clearly identified in the manufacturer's written system specification and shall be demonstrated during the testing of the system. Achieving and maintaining fluid cleanliness from component manufacture through life of field should be part of the overall systems approach to design, manufacture, test and operation.

Typical cleanliness levels are ISO 4406, Class 15/12.

Note For the purposes of this provision, AS 4059^[51], Class 6B-F is the equivalent of ISO 4406, Class 15/12.

All control fluids introduced into the system shall meet the selected cleanliness requirements. Provisions shall be made to maintain cleanliness (e.g. filters) and to take samples.

Methods for circulation and flushing out seawater and solid particle contamination should be considered for the lifetime of the system.

The subsea hydraulic system should be designed to tolerate some contamination by seawater and solid particles. In addition, the components within the hydraulic system shall be tolerant to seawater ingress and the potential corrosion that it can cause. Vulnerable parts with very low fluid consumption (e.g. DCV pilot stages) shall be protected by filters or suitable screens.

System cleanliness should be verified in accordance with ISO/TS 16431.

All parties who can influence fluid cleanliness, including drilling and topside construction personnel, normally unfamiliar with subsea practices, should be made aware of the importance of fluid cleanliness and that working procedures to achieve, test and maintain cleanliness are to the required standard.

5.4.3.3 Seawater ingress and compensation

The potential to ingress of seawater during deployment and use shall be minimized. Recommended measures include removal of residual air, flushing immediately after deployment, and pressure compensation of hydraulic system.

The seachest/compensator shall be sized for the maximum required fluid volume, with a 25 % margin if the seachest/compensator is being topped up during operation of the system (looped circuit). If the seachests/compensators are isolated from the system, a minimum margin of 100 % is required (non-looped circuit).

As a minimum, the following situations shall be reviewed:

- compensation of the SCM itself, for retrieval or deployment, when not connected to the christmas tree;
- prevention of hydraulic lock during emergency shutdown;
- the effect of ROV manual over-ride, with- and without external connections;
- fluid shrinkage during cool-down (SCSSV line).

5.4.3.4 Overpressure protection

System pressure-relief (safety) valve settings shall not exceed design pressure.

The setting of the primary relieving device shall not be greater than the design pressure.

5.4.3.5 Vibration and pressure pulses

Design of the hydraulic system should consider water hammer, high-pressure pulses and vibration on lines, valves and couplers. This shall include external sources, e.g. chokes. If high cyclic loads are identified, the design and manufacturing should be reviewed to mitigate associated risks, e.g. the use of butt-weld hydraulic connections.

5.4.4 Electrical system

The electrical power for the surface control equipment of an electrohydraulic control system, its associated interfaces, and the subsea equipment should be supplied from an UPS to ensure continued operation in the absence of primary power for a minimum period of 30 min.

Typically, the UPS system should include isolation and regulation to ensure a clean constant supply of electrical power. In the case of communication on power, the UPS shall have a THD figure of better than 3 % with no more than 60 % of the THD concentrated in the third harmonic.

In order to minimize the number of conductors in the control umbilical, signal multiplexing and combining power and signal on the same pair of wires should be considered. Possible increased voltage stress on umbilical or distribution wires caused by single insulation failures should be considered. For subsea assemblies, electrical components of high reliability shall be used. Components shall be procured to industrial grade or better wherever possible. The electronic control system supplier shall be able to provide a quality assurance system or test documentation to demonstrate component and system reliability levels appropriate to the system application. Typically, this should demonstrate failure probabilities acceptable for the design life of the control system.

The design of the subsea electrical distribution system shall consider the possibility of retrieving failed portions of the distribution network whilst the redundant and operational parts are in operation.

With respect to "live disconnect" of subsea wet-mate connectors, consideration should be given to arcing damage that can occur in the event of slow separation speed. Electrical distribution systems should be designed such that "live disconnect" is not required during normal operation, maintenance or, if possible, during failure mode operation or recovery periods.

Topside equipment should be designed to facilitate modular replacement.

5.4.5 Redundancy

The level of redundancy depends on the actual field development, control system uptime availability target and reliability of equipment used. Generally the following guidelines are applicable.

- a) As a design intent, the level of redundancy should prevent or minimize the loss of subsea production due to a single-component failure or common-mode failure.
- b) Redundancy is most important if component replacement is difficult, or if significant production availability or operating capability is lost through single-component failure.
- c) If redundant components are used, the reliability of the method for switching from the primary to the backup component should be evaluated. Active redundancy, which enables a seamless transfer to a secondary system in the event of a primary system failure, should be implemented if practical.
- d) The subsea electrical distribution system design should be redundant or include spares that can be configured to replace failed circuits. Facilities should be provided to enable routine monitoring of spare-line integrity.
- e) Consideration should be given to providing completely segregated redundant electrical systems. The subsea hydraulic distribution system should be redundant or should include spares that can be configured to replace failed lines in either LP or HP service.
- f) The subsea chemical-distribution system and supply line should have redundancy consistent with the importance of the treatment chemical.
- g) The number of spares in the umbilical should be specified based on the redundancy needed and relative impact on umbilical design, e.g. spares which fill space in a given cross-section add less cost than those which lead to a diameter increase.
- h) Redundancy of instruments should be based on criticality and retrievability of the sensors.
- i) The level of redundancy throughout the system is influenced by the complexity and reliability. An analysis of the expected benefit from redundancy should be performed for all critical parts of the system.

5.4.6 Reliability

Required reliability of the subsea control system should be optimized to result in maximum benefit. The use of high-reliability components should be compared against redundant components of more standard quality. Special consideration should be given to the reliability of components that are difficult to repair or replace.

Minimum required reliability, mean time to repair and availability targets for subsea equipment should be stated for each project.

The demonstration of these targets should be part of equipment acceptance criteria.

Critical sensor systems located on subsea trees or manifolds should have component reliability, or reliability obtained by redundancy, that is optimum relative to the need for the sensor data and the risk of subsea intervention. This is most important for sensors that trigger safety or shutdown responses.

Reliability figures for critical components and assemblies should preferably be documented by field data or alternatively justified by calculations, tests or an accepted industry data base (such as OREDA)^[53].

5.5 Functional requirements

5.5.1 General performance requirements

Control system equipment built to this part of ISO 13628 should perform in a manner which is efficient, safe and protects the environment. Performance requirements for the control system as a whole should

- provide for individual or multiple operation of all remotely controlled subsea valves;

- provide sufficient data-readback information to operate the system safely and to react promptly to conditions requiring PSDs;
- provide ESD capability that ensures the subsea system will shutdown production safely within the time specified by this part of ISO 13628 or by applicable regulatory authorities for all production scenarios, including simultaneous drilling, completion and workover operations.

5.5.2 Operating pressure

The control system shall be capable of supplying control fluid at a pressure which is sufficient to open subsea valves under the worst case set by valve manufacturer specifications. The minimum working pressure shall be at least 10 % greater than the minimum opening pressure specified by the manufacturer for the worst-case condition of the actual installation. The decrease in operating pressure while a subsea valve is being actuated should not reach a value at which any of the other previously actuated subsea valves change commanded state.

Pressure required to operate SCSSV is higher than for wellhead control. As the pressure required to open an SCSSV is a function of the tubing pressure, which is itself variable over time as the well depletes, the value of the SCSSV hydraulic pressure shall be selected to ensure that the SCSSV is not over-pressured at the end of well life. Having an operator-variable SCSSV hydraulic pressure at the HPU mitigates against SCSSV over-pressurizations over well life.

5.5.3 Fail-safe philosophy

Subsea control systems shall be designed to render the production system to a fail-safe status upon loss of hydraulic power. Typically, this is achieved by closure of a USV. Such closure can be achieved by either de-energization of electrical circuits or depressurizing of the hydraulic power supply. If an all-electric-type control system is used, the system shall be fail-safe upon loss of electric power.

There should be no subsea control system component failure that prevents the fail-safe closure of the SCSSV and the designated USV.

5.5.4 Response time

5.5.4.1 Valve closing

5.5.4.1.1 General

The primary constraint on control system response time is set by the requirement to execute promptly a shutdown of the subsea production upon command from the surface facilities. Such shutdowns are associated with discharging a supply of combustible materials to the surface facilities, and/or reducing pollution of the environment in the event of a loss in containment integrity of the subsea system. If closure of a valve is the means by which a downstream segment of piping is protected against overpressure, the response time shall be less than that which would allow the segment to be over-pressured due to continued flow.

5.5.4.1.2 Requirement for contingency closure control mode

All control systems for which malfunction or failure of the primary control system do not necessarily cause the USVs to return to a fail-safe position, and, as such, can potentially allow flow to continue indefinitely, shall be equipped with a contingency closure control mode that can execute the necessary valve closures. If such contingency closure control mode involves bleeding off supply hydraulic pressure, the system shall reset in such a manner as to prevent the automatic reopening of the closed valves when supply pressure is restored. The SCSSVs should be the last valves to close.

5.5.4.1.3 USV closing-time requirement using primary control mode

Upon receipt of a commanded closure, the subsea control system shall complete a closure of the designated USV using the primary control mode with the maximum response time not to exceed 10 min. For multiple-well installations, the USVs on all flowing wells shall close within the designated 10 min time allowance.

5.5.4.1.4 USV closing-time requirement using contingency closure control mode

In the event that a subsea control system failure has necessitated a valve closing operation in a contingency closure control mode that is not in compliance with the 10 min closure-time limitation, the contingency closure control mode shall still execute the closure in a manner that meets the general requirements stated in 5.5.4.1.1.

5.5.4.1.5 Shift time limitation

The shift time portion of the overall response time for a single USV shall be 3 min or less. This shift time limitation may be waived if flow in the subsea well associated with the respective USV has already been stopped by other valves or flow control devices that have previously been closed or that are simultaneously responding to the commanded closure.

5.5.4.1.6 Failure of boost system

Failure of the boost system shall not prevent the fail-safe closure of the USV under the loss of hydraulic pressure.

5.5.4.1.7 Relationship of surface and riser safety system response requirements to subsea control-system response requirements

The response time of an SSV or riser valve following a commanded closure is established by regional regulations for the protection of the surface facility. The response time of these surface and riser safety devices is independent of the requirements for subsea control system response. As such, this is not a part of this performance specification, but should be considered in a total system safety evaluation.

5.5.4.2 Valve opening

If equalization of pressure across the USV is not possible prior to opening, the USV shall be constrained to a shift time not to exceed 3 min. This requirement may be waived if there is another valve or flow-control device in the flowstream that can be closed such that the USV can be opened without encountering a prolonged differential pressure.

5.5.4.3 Demonstration of response time

One of the following four methods shall be used to demonstrate that the response time projected for the control system meets the objectives (prior to installation).

- a) Run a control system simulation using perfectly elastic umbilical volumetric data and valve operator data, typically available from the respective manufacturers. This approach typically results in the most conservative calculated response times.
- b) Run a control system simulation using viscoelastic umbilical volumetric data, based on measurements made on at least 30 m (100 ft) of sample material of pressure and volume versus time. Combine with manufacturer's valve operator data.
- c) Run a control system simulation using a previously calibrated model for an identical umbilical material, allowing for new variables such as control path length, operating pressure, and end device characteristics.
- d) Measure response time directly using actual equipment.

5.5.5 Functional considerations

5.5.5.1 Leak tests and diagnostics

The subsea control system shall be capable of performing required diagnostics and regulatory-mandated leak tests on the subsea equipment. Such leak tests include leak-testing of barrier valves in the HIPPS system, the SCSSV and leak-testing of the designated USV. In the event of leak-test failure, the control system should provide capability to facilitate diagnostics of the failure conditions.

5.5.5.2 Interlocks

The following interlock functions should be evaluated:

- prevent SCSSV from opening unless PMV or PWV is closed;
- prevent SCSSV from closing unless PMV or PWV is closed;
- prevent the cross-over valve from opening unless PMV is closed;
- prevent the PWV from opening unless choke is at preset position.

5.5.5.3 SCSSV or intelligent well completion seal failure

Backflow of well fluids into the subsea control system due to seal failure in the SCSSV or IWCS shall not impair the ability of the subsea control system to execute the fail-safe closure of the USV.

5.5.5.4 Actuation indication

The production control system shall provide a surface indication of the actuation of a selected hydraulic function. As appropriate to the hardware, such indication may be through the use of visual flow indicators, pressure transducers, pressure gauges, position-indication sensors, flow sensors or pressure sensors.

5.5.5.5 Protection of SCSSV

Under commanded-closure conditions, the design of the production control system should protect the SCSSV from slam or creep closure on a flowing stream, through operational procedure or introduction of a delay following the closure of the valves downstream of the SCSSV. Any such provision should not impact the ability of the subsea production control system to close the SCSSV in shutdown conditions.

5.5.5.6 Flushing of SCSSV hydraulic circuit

Provisions for flushing the hydraulic circuit from control module to SCSSV during installation and in the operational phase shall be considered as part of front-end engineering. This function can be implemented by using a dedicated flushing valve in the SCM. Flushing operations shall not result in HP system pressure drop which can affect other wells.

5.5.5.7 Safety isolation during workover

The production control system shall be capable of being positively disabled from the operation of tree control functions while a workover control system is in use on that tree.

5.5.5.8 Control fluid venting and leakage

External venting and leakage of control fluids shall not exceed local regulatory requirements. Internal leakage shall not exceed the control component manufacturer's written specifications. Margins for leakage increase shall be allowed.

Internal leakage shall not threaten the safe operation of the isolation valves particularly the ability to shut-in.

For closed-loop systems, the return system shall be designed for the maximum leakage.

5.5.5.9 Load capability

Product designs shall be capable of sustaining rated loads without degradation, exceedance of allowable stresses or impairment of other performance requirements.

5.6 Design requirements

5.6.1 General design requirements

The design shall provide for reliable and safe operation of the subsea equipment. The design shall also provide means for a safe shutdown on failures of the equipment or on loss of control from the remote control point.

Vulnerable areas for connection such as electrical connectors, hydraulic couplers and stabplates shall be furnished with necessary protection equipment in order to protect the equipment when being unmated and in service and to prevent calcareous build-up and marine growth.

Early in the project, the manufacturer and purchaser should clearly establish utility interface requirements.

5.6.2 Design methods

5.6.2.1 Pressure-containing vessels

All pressure-containing vessels used for applications in excess of 0,1 MPa (15 psi) shall meet the requirements of the ASME Boiler and Pressure Vessel Code, Section VIII, Division 1, or BS 7201-1 or ISO 10945, or any other agreed-upon pressure vessel or accumulator code or standard.

Note For the purposes of this provision, BS 7201-2^[17] is the equivalent of ISO 10945.

5.6.2.2 Electrical devices

All electrically driven motors, motor starters and all other electrical devices shall conform to the requirements of the appropriate approved electrical code for the equipment location.

5.6.2.3 Interconnecting tubing

Vibration-induced fatigue failure of the subsea tubing system shall be considered. All tubing runs shall be installed with sufficient and appropriate clamps. Interconnecting tubing shall meet the requirements of ANSI/ASME B31.3 or any other agreed upon piping code or standard.

5.6.3 Design analysis

5.6.3.1 General

The following analyses shall be performed during detailed design of the production control system for the purpose of establishing system requirements (e.g. performance characteristics, requirements, etc.), and only if they are relevant to the type of control system:

- hydraulic system operation and response time analysis;
- electrical power distribution analysis;

- electrical communication analysis;
- optical communication analysis;
- communication data rate analysis;
- failure mode effects and criticality analysis;
- reliability, availability, maintainability analysis;
- safety assessment analysis (if applicable).

Further the following analyses should also be considered during detailed design:

- a) reliability, availability and maintainability analysis;
- b) failure mode effect and criticality analysis;
- c) structural (static) analysis.

A simulation of the control system shall be created, and analysis made, such that the required opening and closing time requirements for the system can be verified. The response time of the control system shall be simulated in the absence of any bore-pressure assistance to the closure of the valve. The simulation shall properly account for response-time degradation due to use of high density gradient and high viscosity control fluids. Effects of a boost-pressure supply acting to assist the prompt closure of the valve operator may be included in the analysis. However, this does not relieve the supplier from providing a system that meets the requirements of this part of ISO 13628 without the use of a boost system.

5.6.3.2 Hydraulic systems

Hydraulic system analyses should ensure that the hydraulic system performance in the various modes of operation is safe and operationally acceptable. The areas of hydraulic performance that should be addressed are the following:

- time to prime the hydraulic system from a depressurized state;
- opening and closing response times of the process valves under conditions of minimum and maximum process pressure;
- time for the pressure to recover following a process valve opening;
- time to carry out a sequence of valve openings, such as the opening of a tree (neglecting choke valve operation);
- stability of opened control and process valves to pressure transients caused by operation of other control and process valves (sympathetic control valve delatching, process valve partial closing, etc.);
- stability of opened downhole control and safety valves to pressure transients caused by operation of other safety or IWCS valves (sympathetic control valve delatching, process valve partial closing, etc.);
- response time to close process valves in the event of a common close command, such as an ESD vent-down at the surface, venting off hydraulic control valves via supply lines;
- response time and pressure for multiple simultaneous choke operations;
- response time and pressure for subsea quick dump;
- response and pressure for closed-loop systems;

- peak return-line pressure transients that can cause partial opening of closed process valves and damage to hydraulic components with limited return-pressure capability;
- impact that failure of subsea accumulation and return-line boost pressure systems (assist closing systems) has upon the safe operation and closure of the process valves;
- impact of loss of subsea accumulator pre-charge;
- extent of control fluid total loss rate;
- hydrostatic conditions that can give rise to line collapse, seawater ingress, etc., caused by differential hydrostatic pressures resulting from differential heads and differential fluid densities;
- chemical system flow analysis that should establish that a specified supply of well-treatment, start-up and shut-down chemicals is achieved under the range of wellhead flowing and shut-in process pressures.

5.6.3.3 Electrical power systems

The electrical power distribution analysis should establish the following:

- voltage at SEM for maximum and minimum SEM power loads;
- voltages at SEM at maximum and minimum numbers of SCM on the subsea electrical distribution line;
- voltages at SEM at minimum and maximum umbilical lengths;
- voltages at SEM at redundant and non-redundant power distribution, if applicable;
- voltages at SEM at cable parameters for dry and wet umbilical insulations, if applicable;
- voltages at SEM at the limits of cable parameters such as inductance, capacitance, resistance and conductance (noting that some parameters may change when subsea);
- SEM component stress levels that should be maintained within acceptable limits for normal and degraded modes of operation;
- minimum and maximum subsea power requirements;
- maximum current load;
- power factors for full range of control system operating conditions.

5.6.3.4 Electrical communication systems

The electrical communication analysis should establish the following:

- signal voltage in SEM and topside at minimum and maximum umbilical lengths;
- signal voltage in SEM and topside at maximum and minimum numbers of SCM on the subsea electrical distribution;
- signal voltages in SEM and topside at worst-case cable transmission line parameters, such as inductance, capacitance, resistance and conductance (noting that some parameters can change when subsea and are also subject to discrepancies between calculated and manufactured values);
- interference from the subsea and topside power supplies or other sources of electromagnetic energy in the signal frequency band;

- power frequency components in subsea and topside receivers;
- signal voltage in SEM and topside at cable parameters for dry and wet umbilical insulations;
- BER and signal-to-noise in SEM and topside at minimum and maximum umbilical lengths;
- acceptable amplitude variation within the frequency band required by the modem system at minimum and maximum numbers of SCM on the subsea electrical distribution;
- subsea communication data transfer response time for downlink commands and uplink data transfer. The response time shall be calculated for the maximum number of data points and maximum number of SEM connected to one line and include communication load from possible other users like IWCS.

In the case where IWCS share the same communication link as the production control system, special consideration shall be made to communication system operation during critical functions like PSD to ensure the safety integrity level specified is maintained.

5.6.4 Design review

Control-system design documentation shall be reviewed and verified by a qualified individual other than the individual who created the original design.

The design verification of the subsea components shall be sufficiently rigorous to reflect the importance and cost of repair if it should fail. Such verification of design shall include all life phases such as installation, operation and recovery.

5.6.5 Control system design documentation

5.6.5.1 Manufacturer's engineering data records

Engineering data records shall include required analyses listed in 5.6.3, other design analyses performed by the manufacturer and FAT procedures and records.

5.6.5.2 Installation, operating and maintenance manual

The installation, operating and maintenance manual should incorporate information on the following:

a) installation procedures:

The manufacturer shall write procedures that prepare the equipment for installation and commissioning in a manner which is effective and minimizes the risk of damage. The procedures shall cover the testing of control modules, control umbilicals and connections just prior to, during, and immediately following installation.

b) operating procedures:

Operating procedures shall be prepared for use by field personnel and service technicians, and should include adequate schematics and block diagrams. They shall define the following:

1) general description and features:

This portion shall describe the function of each major component of the system and define its capabilities and interfaces with other components.

2) general function and shutdown philosophy:

This information shall include block diagrams, panel logic and schematics that represent the control system. Sensor-initiated inputs and outputs should be included. The interface between the operating circuits on host facilities, instrument and emergency utilities, such as air, water and electricity, shall

be included. The nature and purpose of all signals to and from the surface-facility fire and safety systems, motor control centre, and supervisory controls shall be identified. The approximate time required for shutdown actions to occur should be noted.

3) system checkout:

The system checkout shall be based on FAT and integrated tests described in Clause 11. The purpose of the procedure is to verify the correct function of all shutdown inputs and safety devices, and to verify the correct setting of all control system adjustments. The procedure should be written to allow testing to the fullest possible extent without interrupting well production. Where mechanical or electrical overrides are required, their active status shall be clearly indicated. A document should be prepared that collects all the set points and allowable ranges for the process variables. This document can be updated as needed and attached to the procedures.

The system checkout shall include a test and documentation of the safety shutdown system.

c) maintenance procedures:

The manufacturer shall furnish suitable instructions concerning field assembly and maintenance of the equipment. Instructions for periodic checks and/or replacement of control system surface equipment should be included.

5.6.5.3 Manufacturer's data record book

The manufacturer shall collect data record information for the supplied equipment, including subcontractor supplied equipment as required by the customer. The following should be included:

- general assembly drawings with list of materials;
- electrical schematics;
- hydraulic schematics;
- interface drawings;
- material certificates with appropriate test reports;
- component data sheets, including performance specifications;
- load test reports;
- welding procedures;
- certificates of conformance.

6 Surface equipment

6.1 General

The purpose of Clause 6 is to set forth additional requirements that are specific to the surface-installed equipment that is part of a subsea production control system. All such surface-installed equipment shall be designed to perform in accordance with these additional requirements.

6.2 General requirements

All host facility-based production control system equipment shall be built and documented according to specifications applicable for the host facility where the equipment will be located. Relevant standards and installation specifications shall be a part of the contractual documentation for the specific project.

6.3 Functional requirements

The functional requirements for the surface equipment typically include all or some of the following:

- supply and conditioning of electric and/or hydraulic power for the subsea equipment;
- communication with the subsea equipment;
- control and monitoring of subsea equipment;
- communication with the host process equipment;
- ESD/PSD;
- chemical injection;
- recording and storing data;
- communication with drilling rig for rig-initiated shutdown.

6.4 Design requirements

6.4.1 Master control station (MCS)

6.4.1.1 The MCS is the unit that controls and monitors the subsea production system. It can range in complexity from a manual hydraulic panel to an automated computer system. As an automated computer system, it can be configured in three possible ways:

- fully integrated with the host DCS;
- as a stand-alone terminal being the primary interface for control of the subsea system;
- as a stand-alone terminal with interface to both the DCS and subsea equipment. The host DCS is the primary operator's interface for control of the subsea system. The MCS is secondary, but able to perform subsea control should the DCS or the link to the DCS fail.

6.4.1.2 The MCS shall be designed to include the following capabilities to

- operate safely in the sited environment;
- respond to the host safety systems;
- provide effective operational interface;
- display and warn of out-of-limit (fault) conditions;
- display operating status;
- provide a shutdown capability.

6.4.1.3 The MCS may optionally provide the following additional capabilities:

- sequenced operation of valves;
- software interlocks;
- process-control interconnections with host facility;
- data collection, storage, analysis and presentation;
- remote communication to offsite control centre;
- interface with remote shutdown system on drilling or workover vessel;
- rate of change of pressure analogue(s) for rudimentary leak detection;
- hydrate detection by pressure/temperature curve comparison;
- flowrate control by detection of choke position and pressure sensors up- and downstream of choke.

6.4.1.4 The application software should be simple. Start-up operations after shutdown situations should be under the complete control of the operator, having the appropriate level of access, with a minimum number of inherent interlocks.

The MCS or DCS shall provide the operator interface and automated functions for the production control system, as appropriate to the selected configuration.

The MCS should be installed in a safe area.

If a dual redundant configuration is used, transfer to the secondary or hot standby controller shall be bumpless with no loss of data or control.

The MCS should allow for post-installation expansion, both of hardware and software. The level of expandability of the MCS shall be defined during the equipment specification phase. The MCS shall be capable of post-installation modification and upgrading of software.

6.4.2 Electrical power unit (EPU)

For electrohydraulic systems, an EPU may be installed as a separate system, or may be combined with the modem unit or the MCS.

The EPU, which is normally powered from the UPS, supplies electrical power to the subsea wells via the control umbilical. The EPU should include safety devices which ensure that, under electrical fault conditions, the equipment and personnel are protected from electrical hazard.

If redundant power conductors are provided in the umbilical, the output voltage of the EPU should be individually adjustable for each channel of each umbilical power pair. Each pair should be galvanically segregated from the rest of the system. The design shall allow for individual pair connection/disconnection.

The design should allow easy access to individual power systems for maintenance and repair.

The following EPU parameters should be monitored by the MCS or DCS:

- input voltage;
- input current;
- umbilical voltages/currents (optional for communication lines);

- overvoltage and overcurrent alarms;
- line insulation (optional).

The EPU shall be designed to operate safely in the sited environment.

6.4.3 Modem unit

Modems, filters and isolation transformers are typically included in the unit.

The modem unit may either be connected to an MCS, dedicated to the production control system or, alternatively, may interface directly with the host facility DCS via a communication interface unit (part of the DCS).

In either configuration, the communications protocol shall provide a mean of ensuring the security of the data being transferred.

If redundant communication paths are provided, the redundant elements shall not share common hardware, such as modems or power supplies. It shall be possible to switch communications easily between the redundant paths. This feature should, preferably, be automatic with the status of the communication links being announced to the control system operator.

The surface-to-surface communications link should employ an industry standard communication protocol.

The following modem unit parameters should be monitored by the MCS or DCS:

- input voltage;
- input current;
- umbilical voltages/currents;
- line insulation (optional).

The modem unit shall be designed to operate safely in the sited environment.

6.4.4 Uninterruptible power supply (UPS) (optional)

The UPS shall supply electrical power to the EPU, modem unit and the MCS.

Only critical components that are necessary for operation of the production control system should be powered from the UPS. HPU electrical pumps should not be regarded as critical. Each UPS shall have a capacity of 100 % of the total load, and should be designed to include future planned expansion of the production control system.

The UPS battery back-up shall be capable of running the system for at least 30 min after loss of host-facility power.

The following parameters should be monitored by the MCS:

- input voltage;
- input current;
- UPS output frequency;
- UPS bypass mode;

- UPS on-line mode;
- UPS failure.

6.4.5 Hydraulic power unit (HPU)

6.4.5.1 General

The HPU shall supply filtered and regulated hydraulic fluid to the subsea installations.

The HPU shall include provisions for obtaining and maintaining the specified cleanliness requirement, such as drainage or circulation and filtration capability, should the fluid become contaminated. Output fluid from the HPU shall satisfy a cleanliness requirement according to manufacturer's written specification, as defined in ISO 4406.

Note For the purposes of this provision, AS 4059^[51] is the equivalent of ISO 4406.

Proper fluid sampling points shall be included to enable safe fluid sampling from the active part of the HPU hydraulic system.

HPUs shall be capable of being maintained without depressurizing the system.

HPUs should not have automatic filter bypasses that enable unfiltered fluid to pass around a filter blockage.

Redundancy should be provided on key components such as pumps and filters.

The same type (style) of tubing fitting should be used for each pressure class throughout the system.

The HPU shall be designed to operate safely in the sited environment.

The design should allow maintainable components within the unit to be isolated for servicing or replacement without interrupting the normal operation.

Electrical equipment in the HPU shall be designed to an ingress protection rating appropriate for the sited environment

The layout of the HPU should allow easy and safe access to all components for maintenance and repair.

6.4.5.2 Accumulators

The accumulators shall comply with ASME Boiler and Pressure Vessel Code, Section VIII, or BS 7201-1 and ISO 10945 or any other agreed pressure vessel or accumulator code or standard.

Note For the purposes of this provision, BS 7201-2^[17] is the equivalent of ISO 10945.

All surface-located accumulator systems shall have a pressure-relieving device to prevent over-pressurization. This applies both to the gas side in the form of fusible plugs or burst discs, and the hydraulic side in the form of safety relief valves.

Nitrogen pre-charge pressure should be significantly lower than normal hydraulic operating pressure to maximize stored energy in case of a supply pump failure.

Accumulator capacity shall be in accordance with the following criteria (the one criteria giving the greatest volume shall be used):

- allow all valves on one subsea tree to be opened and closed without requiring recharge of the accumulators; to maintain sufficient subsea pressure to keep process valves open, if a failure of the HPU pumps occurs, for a period of 12 h neglecting all other methods of fluid energy storage, such as umbilical line expansion and subsea accumulation;
- prevent short pump-run cycles, which would be detrimental to the life and reliability of the pumps;

- a minimum HPU accumulation of two 37 l (1,3 ft³) accumulators for the common LP header, and two 10 l (0,35 ft³) accumulators for the common HP header.

Failure of one accumulator (if more than one is used) shall not impair more than 50 % of the surface system capacity. Under such failure conditions, available pressure shall not drop below the minimum level required to maintain system operations.

Visual indication of low nitrogen pressure should be considered.

6.4.5.3 Pumps

Control devices shall be incorporated to shut off pumps upon occurrence of low fluid level in the supply reservoir.

Control devices shall be incorporated to cycle pump(s) on and off to maintain pressure within operating limits.

Pumps shall be fitted with isolation valves, a pressure-relief valve and a non-return valve at each pump discharge line.

The pressure-relieving device shall be installed at the output of all high-pressure pumps upstream of any blocking or isolation valves.

Anti-condensation heaters should be considered for electrical motors.

6.4.5.4 Reservoirs

The main reservoir should have a minimum capacity of 1,5 times the volume required to pressure charge the system including surface and subsea accumulators, umbilical and all valve operators and one full open and close cycle of chokes. However, if the main reservoir has a capacity equal to or greater than 2 000 l (70,6 ft³), a spare capacity of 750 l (26,5 ft³) is acceptable. The reservoir(s) should be sized, or alternative disposal means provided, to accommodate drainage of all subsea valve operator, accumulator and umbilical fluid in case of a total system depressurization. Provision shall be made for the reservoir to overflow to a designated line in the event of overfilling.

The hydraulic fluid reservoirs should be equipped with visual level indicators. Calibration of level transmitters should be possible without draining of tanks.

The reservoir(s) should be fitted with an inspection/access hatch and tank-fill breather or pressure-relief mechanism.

The hydraulic fluid tanks should be designed to minimize build-up of contamination and facilitate flushing.

Fluid reservoirs shall be made from non-corrosive material and should be equipped with circulating pumps and filters. Sample points shall be located no higher than pump suction ports, taking samples from the active part of the reservoir.

Consideration should be given to the use of two fluid reservoirs, one used for the transport of new fluid, return fluid from subsea (if implemented) and return fluid from depressurization of the system; the other, used for supplying clean fluid to the subsea system.

6.4.5.5 Control and monitoring

The HPU is typically controlled locally, but may be controlled and monitored from the MCS. Consideration should be given to the response time of the control loop.

If primary control is from the MCS, provision shall be made for local control. A local control panel shall be fitted with all the necessary gauges, switches, valving and indicators to enable operator control and monitoring. Provision for setting pumps in manual mode shall be provided.

If the facilities provide for ESD capability, then the HPU and control panel, if applicable, shall incorporate devices to bleed-off system-control pressure upon execution of ESD.

Should an ESD that requires hydraulic-pressure bleed-off occur, inadvertent reset of any HPU/ESD circuit shall be prevented while ESD conditions are still present.

The HPU parameters monitored may include the following:

- non-regulated supply pressure(s);
- regulated supply pressure(s);
- fluid levels;
- pump status;
- delivery flowrates;
- return flow;
- filter status;
- ESD indicators.

Monitoring of filter clogging should be provided preferably using remote indication measures that provide operator alarms.

Hydraulic fluid leak detection with the HPU should be considered. This information is valuable in identifying and diagnosing subsea problems.

6.4.6 Chemical injection unit (CIU)

6.4.6.1 General

In 6.4.6 are addressed surface facilities for the supply of well-treatment chemicals to the subsea production system via the production control system. Excluded from these requirements are storage and handling of the chemicals.

6.4.6.2 General requirements

The CIU shall supply filtered and regulated or metered chemical injection fluid(s) to the subsea installation. The CIU supply pressure is typically sufficient to deliver fluid into the wellbore, subsea tree, or other delivery points at a pressure in excess of the shut-in pressure.

For treatment chemicals that are delivered in specific rates, the CIU system should provide a means to vary and set the rate to meet the specified delivery rate. The topside unit is always the source of pressure, but might not incorporate flow control elements.

The CIU should contain provisions for obtaining and maintaining the specified cleanliness requirement. Output fluid from the CIU shall satisfy a cleanliness requirement according to manufacturer's written specification, as defined in ISO 4406.

Note For the purposes of this provision, AS 4059^[51] is the equivalent of ISO 4406.

The use of redundancy should be considered for critical components such as pumps, filters and flow-rate control devices.

Any accumulators used in the CIU shall comply with ASME Boiler and Pressure Vessel Code, Section VIII, Division 1, and BS 7201-1 and ISO 10945, or any other agreed pressure vessel or accumulator code or standard.

Note For the purposes of this provision, BS 7201-2^[17] is the equivalent of ISO 10945.

All accumulator systems shall have a pressure-relieving device to prevent over-pressurization. This applies to both the gas side in the form of fusible plugs or burst discs, and the hydraulic side in the form of safety relief valves.

The CIU shall be designed to operate safely in the sited environment. Special consideration shall be given to toxicity and flammability typical of the injection chemicals.

The design should allow maintainable components within the unit to be isolated for servicing or replacement without interrupting the normal operation.

The layout of the CIU should allow easy and safe access to all components for maintenance and repair.

6.4.6.3 Chemical injection pumps

Control devices shall be incorporated to shut off chemical injection pumps upon occurrence of low fluid level in the supply reservoir.

Chemical injection pumps shall be fitted with isolation valves, a pressure-relief valve and a non-return valve at each pump discharge line.

The pressure-relief device shall be installed at the output of all high-pressure pumps upstream of any blocking or isolation valves.

Pump selection should give consideration to chemical injection fluid.

6.4.6.4 Reservoirs

The chemical injection fluid reservoirs, if integral with the CIU, shall be equipped with visual level indicators. Calibration of level transmitters, if supplied, should be possible without draining the reservoir.

The chemical injection fluid reservoirs, if integral with the CIU, should be designed to minimize build-up of contamination and facilitate flushing.

To prevent undesirable contact between air and chemicals, a bladder tank or a blanket protection system should be considered.

Fluid reservoirs shall be made from non-corrosive material. Sample points shall be located no higher than pump suction ports for taking samples from the active part of the reservoir.

6.4.6.5 Control and monitoring

The CIU is typically controlled locally, but may be controlled and monitored from the MCS.

If primary control is from the MCS, provision shall be made for local control. A local control panel shall be fitted with all the necessary gauges, switches, valving and indicators to enable operator control and monitoring. Provision for setting pumps in manual mode shall be provided.

The CIU and control panel shall incorporate devices to terminate injection upon execution of an ESD/PSD.

The CIU parameters monitored may include

- non-regulated supply pressure(s);

- regulated supply pressure(s);
- fluid levels;
- pump status;
- return flow (if applicable);
- filter status;
- delivery flowrate.

Monitoring of filter clogging should be provided, preferably using remote indication measures that provide operator alarms.

6.4.6.6 Fluid compatibility of components and materials

All surfaces and seal materials in contact with the chemical injection fluids shall be verified to be compatible.

Some treatment chemicals require anaerobic conditions to prevent oxidation. Bladder tanks or variable volume tanks should be used if such chemicals are selected.

6.4.7 Hydraulic control fluid

6.4.7.1 General

The fluid in a subsea control system is intended to transmit both signals and power from one point in the system to another. The fluid may be either oil-based or water-based.

All control fluids shall provide inhibitors to prevent corrosion, biological growth and to tolerate a degree of seawater ingress without having a significant effect upon performance and characteristics.

The fluid is expected to remain in some parts of the system for the life of the project. Since most projects have a life of 10 years to 20 years, the long-term stability of the fluid is extremely important.

Reference should be made to Annex C for detailed information on control fluid specifications and testing.

6.4.7.2 Design

Any water-based hydraulic fluid shall be an aqueous solution (not emulsion) of its components. The fluid shall retain its properties and remain a homogeneous solution, within the temperature range, from manufacture through field-life operation.

Any oil-based hydraulic fluid shall be a homogeneous miscible solution of its components. It shall retain its properties and remain stable as a solution, within the temperature range, from manufacture through field-life operation.

6.4.7.3 Fluid compatibility

Hydraulic fluid compatibility with drilling brines such as zinc bromide, calcium bromide, zinc chlorine and calcium chloride shall be considered.

7 Subsea equipment

7.1 General

The purpose of Clause 7 is to set forth additional requirements that are specific to the subsea-installed equipment that is part of a subsea production control system. All such subsea-installed equipment shall be designed to perform in accordance with these additional requirements.

7.2 General requirements

Subsea equipment can range in complexity from a simple umbilical interface (direct hydraulic control system) to full electrohydraulic control with multiple-well capability. The subsea-installed equipment shall be designed such that it is safe to install and operate. Running, landing and retrieving shall minimize the hazard to personnel, equipment or environment. Devices requiring diver makeup shall be designed to minimize the possibility of diver injury resulting from sharp corners or edges, and should consider electric shock or stored-energy release. Ease of installation and maintenance should be considered.

All subsea-retrievable items of the same type should be fully interchangeable unless system considerations dictate otherwise. The design should consider shocks, vibrations and pressure/temperature variations experienced during transportation, including land, air and sea freight, and offshore operations during all seasons.

7.3 Functional requirements

The functional requirements for subsea equipment typically include all or some of the following:

- communication with the surface MCS;
- processing and execution of commands from MCS;
- monitoring and transmitting of sensor data;
- monitoring and transmitting of diagnostic data;
- execution of surface or subsea commands under shutdown conditions;
- optional monitoring and distribution of well-treatment chemicals in response to surface commands.

7.4 Design requirements

7.4.1 Subsea hydraulic systems

7.4.1.1 Subsea hydraulic distribution system

The subsea hydraulic distribution system distributes hydraulic power from the umbilical termination head to each well.

Consideration should be given to preventing pressure being trapped in critical tree-valve operators or other fail-closed safety systems in the event of inadvertent separation of hydraulic interfaces.

Design of the hydraulic system shall employ self-sealing hydraulic couplings that minimise seawater ingress during subsea connection/disconnection.

Design of template/manifold hydraulic distribution systems should consider having ROV-reconfigurable connector plates or diver-operated isolation devices, so that leakage can be isolated from the system. A subsea hydraulic distribution module is an approach that allows retrieval, re-plumbing and replacement to

isolate failed lines and activate spares, if available. Consideration should be given to the provision of two-series isolation against hydraulic pressure when designing live disconnect diver-operated distribution systems.

Design of hydraulic systems should consider single-point (and common mode) failures, which may be addressed through the separation of physical routes and hydraulic isolation of redundant supplies.

7.4.1.2 Multifunction connections

Multifunction connections should be polarized or keyed such that only one possible orientation is possible. Labelling for proper identification should be considered.

Loads created during hydraulic coupler connection and disconnection which creates hydraulic lock, pressure intensification and vacuum shall be addressed when selecting the hydraulic couplers and the method of securing.

7.4.1.3 Pipe, tubing and hoses

All pipe/tubing shall have a minimum 6 mm (1/4 in) nominal outside diameter.

All pipe/tubing shall be supported and protected to minimize damage during testing, installation/removal and normal operation/ maintenance of the system.

The use of continuous piping or tubing with welded connections is preferred over the use of compression fittings and screwed fittings. National pipe thread (NPT) fittings should be avoided where possible due to potential to generate contamination and the undefined extent of engagement.

Allowable stresses in pipe/tubing shall be in accordance with ANSI/ASME B31.3 or any other agreed piping code or standard.

Design should take into account the following:

- allowable stresses at working pressure;
- allowable stresses at test pressure;
- effects of water hammer;
- external loading;
- collapse;
- manufacturing tolerances;
- fluid compatibility;
- flow rate;
- possible damage arising from incorrect connection;
- corrosion/erosion;
- temperature range;
- connection requirement;
- vibration from external sources;
- impact damage from ROV operations.

All hose assemblies shall meet the criteria described in ISO 13628-5.

Note For the purposes of this provision, API Spec 17E^[10] is the equivalent of ISO 13628-5.

7.4.1.4 Seachest compensation chamber

The capacity of each seachest/compensation chamber tied to the spring/boost side of the subsea-valve operators should be at least 125 % of the total swept volume for simultaneous actuation of all operators tied to the chamber. The use of bypass check valves should be considered to prevent sea chest damage.

7.4.1.5 Valve actuators override

Design of the hydraulic system shall consider hydraulic lock and seawater ingress possibility in the event of manual valve override, e.g. SCM removed.

7.4.1.6 Subsea accumulators

Subsea accumulators with bladders and dynamic seals are susceptible to deterioration and failure. They should be installed in a manner that permits their removal and maintenance over the life of the system.

Consideration should be given to designing subsea accumulators to comply with ASME Boiler and Pressure Vessel Code, Section VIII, Division 1, and BS 7201-1 and ISO 10945, or the applicable code or regulation which applies.

Note For the purposes of this provision, BS 7201-2^[17] is the equivalent of ISO 10945.

However, if not designed to comply with these standards, personnel safety during land testing and other above-water operations shall not be compromised.

Accumulator selection should consider minimizing gas pre-charge loss due to diffusion or leakage.

The accumulator system design shall consider loss of accumulator efficiency with increasing water depth.

Subsea accumulators may be mounted internally or externally (local or remote) to the SCM. If mounted external to the SCM, accumulator shells should be painted to inhibit the absorption of hydrogen evolved from the cathodic protection reaction.

7.4.2 Chemical injection systems

7.4.2.1 Subsea chemical-injection distribution system

The subsea chemical-injection distribution system distributes chemicals from the umbilical termination head to each well or manifold header. In addition, it may provide the means for supplying and bleeding fluid used in pressure testing and in equalization of pressure differential across flow-control devices. It may also support the removal of fluid from the well annulus for leak detection and during the normal warm-up of a well.

Depending on the well-treatment fluid, the flow capacity of the chemical-injection distribution system may be substantially greater than that of the hydraulic distribution system. Additionally, the pressure rating of the components is typically higher (compatible with wellhead system rating) and corrosivity of the fluids conveyed is typically more severe.

Design of template/manifold chemical-injection distribution systems should consider having ROV- or diver-operated isolation devices, so that leakage can be isolated from the system. A subsea hydraulic distribution module may include chemical-injection lines, allowing for retrieval, re-plumbing and replacement to isolate failed lines and activate spares, if available. Consideration should be given to provision of two-series isolation valves against supply pressure when designing live disconnect diver-operated distribution systems.

Design of chemical injection systems should consider single-point (and common mode) failures, which may be addressed through separation of physical routes and flow isolation of redundant supplies.

7.4.2.2 Pipe, tubing and hoses

All pipe/tubing shall have a minimum 6 mm (1/4 in) nominal outside diameter.

All pipe/tubing shall be supported and protected to minimize damage during testing, installation/removal and normal operation/maintenance of the system.

Allowable stresses in pipe/tubing shall be in conformance with ANSI/ASME B31.3 or any other agreed piping code or standard.

Design shall take into account the following:

- allowable stresses at working pressure;
- allowable stresses at test pressure;
- external loading;
- collapse;
- manufacturing tolerances;
- fluid compatibility (injection, annulus and wellbore fluids);
- flow rate;
- corrosion/erosion;
- temperature range.

All hose assemblies shall meet the applicable criteria described in ISO 13628-5.

Note For the purposes of this provision, API Spec 17E^[10] is the equivalent of ISO 13628-5.

7.4.2.3 Special considerations

The design shall consider the following:

- friction and wear increase in methanol service;
- seal material compatibility with injected and produced fluids;
- corrosivity of injected and produced fluids;
- permeation of fluids through hose liner materials (typically low-mass constituents);
- selection of control valves and other flow control devices;
- metal-to-metal seals and methanol. An additional resilient elastomer seal should be included as back-up. This is due to problems resulting from cavitation and flow-induced material degradation (erosion wear).

If diffusion of chemicals through hose materials is anticipated, the system design should ensure that the diffused chemicals do not contaminate the hydraulic control fluid through either leakage or secondary diffusion.

The chemical injection system shall be compatible with a range of chemicals that may be used during the life of the field. The chemical injection system shall be appropriate for contact with wellbore fluids.

Check valves should not be relied upon as pressure-isolation devices.

National pipeline regulations can demand specific testing requirements for chemical systems.

7.4.3 Subsea electrical systems

7.4.3.1 Subsea electrical distribution system

The subsea electrical distribution system distributes electrical power and communication signals from the umbilical termination head to each well.

All electrical connectors that can remain powered after disconnection shall have contacts protected to prevent exposure.

The number of electrical connectors in series shall be kept to a minimum. Redundant routing should, if possible, follow different paths. Consideration should be given to keeping voltage levels as low as practical in order to minimize electrical stresses on conductive connectors.

Manifold electrical distribution cabling and jumper cables from umbilical termination to the SCM should be repairable or reconfigurable by the use of an ROV or a diver.

If one electrical line supplies more than two SEMs, consideration should be given to the ability to isolate a faulty SEM.

If possible, electrical connectors should have orientation keys to prevent misconnection and consequential damage. Alternatively, pin allocation should ensure that misconnection does not give rise to consequential damage. All connectors intended to be left unmated during deployment, use and maintenance shall be fitted with protective caps suitable for direct exposure to seawater.

Each cable-connector pair shall be qualified for use at the specified depth.

Outboard connectors of the ROV stab type that cannot be guaranteed to be bonded to the protection system shall be manufactured from corrosion-resistant materials.

Connection of electrical distribution cabling and electrical jumpers should be made by ROV or diver using simple tools, with minimum demand on rig/vessel time.

A minimum of two barriers should be provided between seawater and any conductor. Barriers should be designed for operation in seawater.

If an oil-filled system is selected, the cable assemblies should be designed and installed such that any seawater entering the dielectric fluid moves away from the end terminations by gravity. The cables should be installed into pressure-compensated fluid-filled lines. The fluid shall be of a dielectric type.

All the materials utilized in the subsea electrical systems shall be compatible with both seawater and, if applicable, the dielectric fluid selected. Qualification testing of new materials to prove their compatibility shall be performed.

Disconnection of powered connectors is not recommended. For safety and long-term connector integrity, the mating and disconnection of electrically live connectors, particularly power connectors, is to be avoided, where practical.

7.4.3.2 Prevention of electrical shock

All subsea systems to be serviced by divers shall be designed to protect divers from electrical shock hazards.

7.4.3.3 Electromagnetic compatibility

The subsea system is required to be compatible with the subsea electromagnetic environment. None of the electrical and electronic elements shall interfere with the functional or safety-related operation of any other element, whether part of the same system or an unrelated system. All elements shall be immune to all predicted EM phenomena to a level determined by the functional or safety-related requirements of the system.

7.4.4 Subsea control module (SCM)

The subsea control equipment for piloted or sequential hydraulic or electrohydraulic systems should be packaged in retrievable units/housings. Depending on the system type, the SCM may include some or all of the following:

- electrohydraulic or hydraulically piloted DCV and other valves (e.g. check valves and shuttle valves);
- feed-through (electrical or optical) connectors and (hydraulic) couplers;
- hydraulic manifolds and tubing;
- internal sensors and transmitters;
- filters/strainers;
- accumulators;
- pressure compensator;
- pressure intensifiers;
- pressure reducers;
- chemical-injection regulation valves;
- SEMs;
- iSEMs;
- valve electronic modules.

To maximize production uptime in multi-well systems, it is desirable that installation and retrieval of one SCM should not adversely affect the operation of any other SCM.

For any development, all SCMs should, where possible, be interchangeable.

All active electronic circuits should be in enclosures filled with nitrogen gas at nominal 0,101 MPa (1 atm) pressure designed for full external pressure conditions. Requirements for internal overpressure relief to environment by procedural or physical means in case of seal failure should be considered.

Electrical elements of subsea electrohydraulic components shall be mounted in a dielectric-fluid-filled and pressure-compensated compartment of the SCM. The SCM design shall be optimized to limit the possibility of draining the dielectric fluid when installed subsea by making any necessary penetrations to the module at as low a level as possible (water usually displaces dielectric fluid until the level of the leak is reached). Although protected from the environment, all interconnecting cables and connectors shall be suitable for direct exposure to the subsea environment, thus providing a double barrier against seawater-induced malfunctions.

Leakage in the hydraulic part of the system shall not affect the integrity of the electric system.

In order to minimize the electrical power consumption, solenoid-operated valves should be pulse-operated and hydraulically latched, with the exception of an electrically held fail-safe valve, if used.

All hydraulic coupler interfaces shall be made up with couplers that seal upon disconnection, unless this compromises safety considerations stated in this part of ISO 13628. The design shall minimize ingress of seawater during running and make-up operation. The coupler half containing the active seal shall be located in the retrievable equipment.

7.4.5 Subsea electronic module (SEM)

7.4.5.1 SEM hardware

The SEM hardware should be based on the use of one or more microprocessors and power supply units in order to obtain an acceptable level of reliability and flexibility in the design.

The SEM shall be protected against water intrusion. The design should include two separate and testable barriers.

The equipment purchaser should consider specifying spare memory capacity for general use. Also specifying additional memory should be considered which can be used in the future for additional SEM capabilities.

The SEM should be designed with spare capacity for increase of capabilities like data processing, external and internal sensors and communication. Current limitation shall be provided for all SEM outputs and sensor excitation supplies.

The SEM interface to sensors and DCVs should be limited to the minimum practical number of signal types and formats. International Standards should be adopted wherever possible.

Description of signals shall be specified for each application by reference to International Standards, or by detailed description of signal type.

Due consideration should be given to standardizing SEMs to enable interchangeability as an alternative to optimizing for specific applications.

Consideration should be given to the inclusion of signal processing of critical measurements in the SEM, if required.

7.4.5.2 SEM software

The SEM software should be structured in functional tasks or modules, which should be designed, coded and tested as independent units. These modules typically conform to the defined tasks, including interrupt tasks in the real-time operating system, or the main program calls in a real-time monitor if a simple sequential scan is used. The module and overall software structure may be designed to make later software updating and maintenance easy to perform.

Coding of software modules should be done in a high-level programming language. Only for small, very time-critical tasks may assembly language be used.

The SEM software should have built-in diagnostic functions to simplify testing and debugging of the modem, subsea computer and sensors.

The SEM should be programmable to allow for reprogramming from the surface while in place.

The SEM can have capacity to temporarily store all relevant data gathered from the subsea production system.

The SEM can be capable of performing sequenced monitoring operations and/or sequenced controlling based on one command from the MCS.

The SEM software can be designed to accommodate the downhole pressure and temperature information.

Requirements for time stamping of data should be considered.

7.4.6 Communication protocol

A reliable and suitable communication system, preferably based on a proven design or an industry standard, is required for supervision, remote control, shut-down and data transfer.

The communication shall transport the defined data signals with high reliability and have sufficient capacity to handle the required traffic in all foreseeable situations. There can be control system operations where the SEM is acquiring a large amount of data (e.g. fast scan of an intelligent well system during well start-up). In these instances, it might not be possible or appropriate, due to data rate limitations, to relay these data to the MCS in real time. Temporary storage of the acquired data in the SEM is acceptable, provided the stored data are subsequently relayed to the MCS in a timely manner. The storage and delayed transmission of data are acceptable only if none of the acquired data is lost or overwritten.

The communications and power systems should be designed to withstand the normal noise and disturbances typically occurring in the operating environment without malfunction. The communications and power systems should accommodate the specified range of voltage and frequency variations and the changes in the number of connected SEMs that the distribution can support.

The MCS should be the governing end of the communication link between the MCS and the SEM.

The communication shall be based on formatted messages. The format should have a reliable identification of message start and a defined length.

Message "time out" shall be included.

Reception of corrupted message and "time out" shall result in retransmission of the message.

Each message shall have cyclic redundancy check or a similar type, leaving no possibility for faulty messages to be received and interpreted as correct.

The protocol should be convenient for loading of the SEM software, external sensor and auxiliary computer software.

Systems electrical and optical communication performance shall meet a BER requirement as specified by the purchaser, with a BER performance design goal of $< 1 \times 10^{-6}$ and $< 1 \times 10^{-8}$, respectively.

Communication between MCS and all SEMs should use the same communication protocol. Communication protocol should be based on a recognised industry standard.

7.4.7 Subsea instrumentation

All subsea instrumentation shall meet the system requirements given in Clause 5. In general, subsea instrumentation should be as simple as possible, so that the number of electrical and hydraulic connections to the SCM is a minimum.

Failure of subsea instrumentation shall not adversely affect the operation of other parts of the system.

For sensors directly exposed to produced fluid, potential blocking of the interface by sand, hydrates or wax should be considered.

Methods of calibration or adjustment of the sensor signals and remote diagnostic should be taken into consideration when designing the system.

The connections and bodies of any sensors used to monitor well-bore conditions shall have a pressure rating appropriate for the maximum operating conditions and shall comply with the requirements of ISO 10423 and ISO 13628-4.

NOTE For the purposes of this provision, API Spec 6A^[8] and API Spec 17D^[9] are the equivalents of ISO 10423 and ISO 13628-4, respectively.

A minimum of two independent barriers shall be provided within the sensor body to be compatible with well-bore fluid, and isolate well-bore fluid from the environment.

A method for inferring the position of hydraulically operated tree valves shall be incorporated.

All devices exposed to well-bore fluids shall be installed with isolation valving between the sensor and the wellbore if it is installed upstream of the tree master valve or the USV, and the location of the sensing element is remote from the wellbore.

7.4.8 Parking and protection provisions

Any physical interface such as hydraulic couplings, electrical connectors shall be protected against the potential of marine growth, calcification by protection system, etc. when left exposed during deployment, use or maintenance. These provisions shall take the form of parking plates, protective covers, etc. which are either permanent features of the subsea equipment or temporary features which can be deployed by ROV or diver.

7.4.9 Isolation of subsea well

7.4.9.1 Isolation of subsea well by ESD

The isolation function concerns only the ESD functions related to the isolation, not the overpressure protection realized through the PSD system.

The sub-system "isolation of subsea well" is defined as the system needed to isolate one well. For a standard subsea well, the sub-system normally consists of the following:

- topside/onshore located ESD node;
- topside/onshore located ESD hydraulic bleed down solenoid valve in HPU;
- topside/onshore located EPU/ESD electrical power isolation relay in EPU;
- PWV and CIV including actuators and solenoid(s);
- PMV including actuators and solenoid(s);
- downhole safety valve including actuators and solenoid(s).

The function starts at the unit where the demand is initiated (unit not included), and ends with the valves shutting in the well.

7.4.9.2 Isolation of subsea well by PSD (optional)

The subsystem "PSD isolation of subsea well" is defined as the system needed to isolate one well by a controlled sequence of valve operation. For a standard subsea well, the sub-system normally consists of the following:

- topside/onshore-located PSD node;
- topside/onshore-located MCS and EPU;
- PWV and CIV including actuators and solenoid(s);
- PMV including actuators and solenoid(s);
- subsea control module including SEM and DCVs.

The function starts at the unit where the demand is initiated (unit not included) and ends with the valves shutting in the well.

7.4.9.3 High integrity pipeline protection system (HIPPS) (optional)

The HIPPS is designed to protect a pipeline and other associated equipment from exposure to high pressure from the subsea wells, thus allowing the pipeline and equipment to be designed for a pressure lower than maximum well shut-in pressure.

The HIPPS should be an autonomous safety system with a local logic system controlling HIPPS activation. The system should include the following elements:

- control of barrier isolation valve(s);
- minimum dual independent pilots or pressure transmitters responding to the pipeline pressure;
- positive control of system reset, to prevent hunting or throttling through the isolation valves;
- reset system.

The safety integrity of HIPPS shall be assessed using a recognized safety system specification such as IEC 61508 (all parts)^[40]. The safety integrity level of the safety functions of HIPPS shall be commensurate with the probability of the safety function to operate on demand and the impact that this failure of the safety function has.

7.4.10 Test equipment

7.4.10.1 General

In order to test each type of equipment during FAT, integration testing and during commissioning offshore, a set of test equipment can be required.

All test equipment shall be compatible with the hazardous area classification of the location in which it is used.

The test equipment should be capable of simulating all primary operations necessary to control and monitor the subsea production equipment in a manner similar to the actual system.

The test equipment should be designed with units identical to the production equipment, where practical.

7.4.10.2 Control module test stand

The control module test stand should support the following test functions:

- verify the mechanical and functional interface between the module and the module receiver plate;
- verify the interface to external process sensors;
- verify the functional operation of the control module.

7.4.10.3 Test hydraulic power unit

The test hydraulic power unit, if utilized, should supply hydraulic fluid at system operating pressures to the control module test stand. The test hydraulic power unit can be capable of performing flushing operations as a general source of clean fluid.

7.4.10.4 Dummy control module

The dummy control module should have a mechanical and hydraulic interface to the receiver plate similar to that of the control module. The dummy module should be equipped with manual valves simulating the real DCVs. The functionality below should be implemented by one or more units:

- verification of control module installation tool operation;
- pressure and functional testing of system hydraulic components;
- flushing of hydraulic systems;
- long-term protection of SCM receiver plate;
- through-connection to downhole gauges for remote interrogation via cable and/or acoustic link.

7.4.10.5 Umbilical simulator

A simulator may be provided to represent the characteristics of the electrical cables within the umbilical.

The simulator should model the impedance of the communications and power conductors in the umbilical.

The simulator, or simulators, should model the range of umbilical lengths in a control system. If a control system features two or more umbilicals connecting between the MCS and an SEM, it should be possible to simulate the entire umbilical string.

If system considerations demand, a hydraulic simulator can also be required.

7.4.10.6 Electronic test unit

The electronic test unit should be capable of performing the control and monitoring functions related directly to the operation of the SCM (one well). All commands described in the communication protocol should be supported. In addition, the electronic test unit should be able to simulate one or more complete control modules. The electronic test unit may be a modular unit including a portable personal computer and necessary power/signal interfaces (signal only).

7.4.10.7 Sensor test unit

The sensor test unit should simulate each type of subsea instruments exclusive of SCM internal instruments, including downhole sensors, if applicable. The sensor test unit may be part of the control module test stand or a stand-alone unit(s).

8 Interfaces

8.1 General

Interfaces between the production control system and other parts of the subsea and host facility systems are critical to successful operation and should be fully defined during initial design.

8.2 Interface to host facility

The subsea production system may be regarded as an extension of the host facility or as an independent system interfacing with the host facility control system.

The interfaces with the host facility are typically

- host facility control system;
- ESD/PSD system;
- chemical injection system;

- utilities;
- UPS (optional).

The platform-installed subsea control system shall functionally interface with, or optionally be integrated with, the host facility control system.

Subsea wells are typically monitored and controlled from the primary operator station. Temporary operator stations may be used for testing, commissioning, programming and maintenance.

The operator station visual display unit displays should provide as much commonality as is reasonably possible with the host facility process control system.

All host facility-based production control system equipment should be built and documented according to specifications applicable for the host facility where the equipment will be situated.

If an integrated control-system philosophy is adopted, the interface between the subsea production control system and the host facility shall, as a base case, be between the MCS and host facility nodes. Optionally, the subsea/topside interface can be defined between the MCS and EPU. Hence the topside modem shall always be regarded as functionally part of the subsea system when this option is selected.

If a fully integrated control-system philosophy is selected for the host facility, the subsea wells shall be monitored and controlled from standard operator stations as first option. In this case, the subsea-production control system application software should be integrated with the host facility software to ease offshore maintenance and operation. The control and monitoring of subsea functions should be as similar as possible to that for the topside-located equipment.

8.3 Interface to subsea equipment

The interfaces with the subsea equipment are typically

a) tree:

- 1) mounting footprint,
- 2) form and fit,
- 3) maintenance access,
- 4) hydraulic function lines,
- 5) tree mounted sensors;

b) choke:

- 1) maintenance access,
- 2) mateable hydraulic and electrical connectors (retrievable chokes);

c) manifold:

see tree items;

d) umbilical:

electric, hydraulic and optical fibre connectors;

e) external instrumentation:

- 1) downhole instrumentation,
 - 2) pressure/temperature transducers,
 - 3) position sensors,
 - 4) erosion probes,
 - 5) corrosion probes,
 - 6) pig detectors,
 - 7) subsea flow meters;
- f) ROV tooling;
- g) SCSSV;
- h) intervention equipment.

8.4 Interface to workover control system

The interface between the production control system and the workover control system should ensure that the workover system has control of all functions that can affect safety of the workover operation. The production control system can be utilized for workover control, provided primary control is from the workover rig.

Emphasis shall be put on cleanliness requirements of the workover control system, so that the production control system is not contaminated during workover operations or during subsequent production operations due to residual fluid in subsea valve operators. System design shall minimize possible seawater contamination of control lines during workover operations, and should consider a means for flushing these lines.

8.5 Interface to intelligent wells

8.5.1 General

If interfaces exist between an IWCS and a subsea production control system, requirements and recommendations for such interfaces are provided by 8.5.

The subsea production control system shall be used to provide a physical location, communications capability, electrical power and hydraulic power for the IWCS. Where there are limitations of existing infrastructure equipment (e.g. retrofit to existing fields), exceptions to this part of ISO 13628 shall be highlighted early in the development process and addressed on a case-by-case basis.

Details are contained in 8.5.2 to 8.5.8 and in Annex E.

8.5.2 Physical

The interface options are as follows:

- option 1: SEM interface an IWCS interface comprising one or two electronic cards fitted in consecutive slots inside the SEM of a SCM;
- option 2: SCM interface an intelligent well SEM, permanently fitted as part of the SCM;
- option 3: external interface an independent enclosure mounted external to the SCM.

The selected options (see E.1 for details) depend upon a number of application-specific factors.

8.5.3 Communications

Communications shall be based on recognized International Standards, oriented to the OSI reference model in accordance with ISO 7498.

TCP/IP shall be used as the protocol between the intelligent well interface card and subsea electronic module (Option 1), or between the intelligent well SEM and the SCM (Option 2).

The following requirements apply.

- The physical layer (layer 1 of the OSI model) shall interface RS 422 full duplex channel RX and TX, with no hardware handshake. Communication signals shall be galvanically isolated on the intelligent well interface and provide separate ground wire from the isolated drivers.
- The data link layer (layer 2 of the OSI model) shall use the point-to-point protocol, as specified in Internet RFC 1661.
- The network layer (layer 3 of the OSI model) shall use IP, as specified in Internet RFC 1332 and Internet RFC 791 for IP v4.
- The transport layer (layer 4 of the OSI model) shall use TCP, as specified in Internet RFC 793.

Communications between the IWCS subsea and the surface facility may make use of the communications used by the subsea production control system. In this case, the subsea control supplier is responsible for passing TCP/IP messages upward and downward.

On the surface facility, the subsea production control system shall provide the TCP/IP link to any machine that needs to communicate with the intelligent well equipment. This also applies to workover control systems unless a direct connection to intelligent well equipment is provided.

The default communication speed between IWCS and the subsea production control system shall be 9 600 bits/s.

Details of this interface are shown in E.2.

The requirements in 8.5.3 cover the production as well as commissioning phases.

In normal operation, the system response time, as measured by a typical "PING" command shall be less than 1 s. This response time may, however, be increased to whatever is necessary for passing emergency messages related to safety operations.

Figure 1 shows one possible implementation of communications interface.

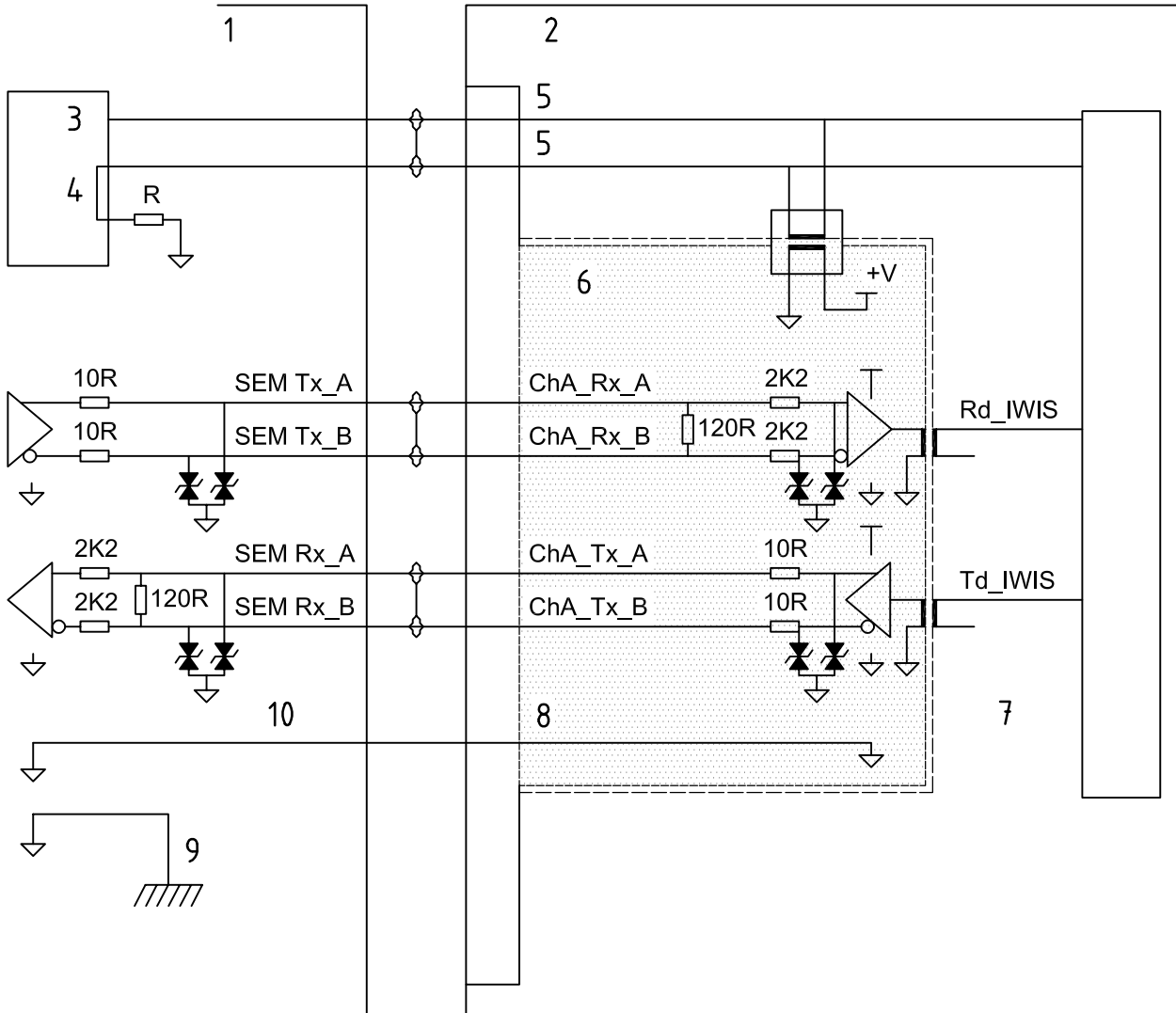

Key

1 SEM	6 galvanic isolation
2 interface board	7 optical or magnetic isolation, voltage depends on design
3 power	8 isolated ground
4 ground	9 SCM chassis
5 power IN	10 signal ground

Figure 1 — Communication port interface

8.5.4 IWCS interfaces with other systems

Three possible system configurations of the IWCS are as follows (see E.3 for more detailed implementation guidelines):

- fully integrated with the host DCS;
- “stand-alone”, where intelligent well control actions are initiated from and data are displayed by a dedicated IWCS, being the primary interface for control of the IWE;

- “interfaced”, which is similar to “stand-alone”, but the IWCS has communication interfaces to the DCS/MCS. Intelligent well normal operations are initiated from and data are displayed in the DCS/MCS. Expert intelligent well operations may be performed by the IWCS.

Time stamping of the intelligent well data shall be performed as close as possible to the source of the data. The resolution of the time format shall be 1 s or better.

8.5.5 Electrical power

The electrical power interface is classified into low, medium and high power.

A low-power interface is defined as a system where the interface resides entirely within the SEM and is provided by power from the SCM.

A medium-power interface is defined as a system where the interface resides outside of the SEM and is provided by power from the SCM.

A high-power system requires power in excess of that available from an SCM and is supplied directly from the umbilical. These systems are considered project-specific.

Floating power supplies shall be provided from the SCM.

Power supply health and status monitoring shall be provided.

E.4 contains details of electrical power requirements.

8.5.6 Hydraulic power

8.5.6.1 Systems

Fluid cleanliness shall be as specified in ISO 4406, Class 15/12.

Note For the purposes of this provision, AS 4059^[51], Class 6B-F is the equivalent of ISO 4406, Class 15/12.

Particular attention shall be paid to the higher temperatures and pressures and contamination levels (in particular well fluids) found downhole.

8.5.6.2 Hydraulic feed-through

For each hydraulic feed-through, the following parameters shall be defined in each case:

- maximum supply pressure from subsea system;
- degree of control of the pressure levels from the subsea system provided to the downhole intelligent completion;
- instrumentation (pressure, flow);
- control valve functionality (bleed, supply and lock positions);
- volumes of fluid.

8.5.7 Tubing hanger penetrations

There shall be space to install a number of electric and hydraulic penetrators in the tubing hanger to accommodate control of intelligent well equipment. The number is project-specific and needs to be verified. A number of four electric signals and four hydraulic lines is recommended unless otherwise specified. These are in addition to any downhole safety valve control or treatment injection lines.

8.5.8 Testing

Qualification and ESS tests shall be performed to reduce failure rates of intelligent well interface equipment installed subsea. Qualification is considered particularly important for equipment that is subjected to a harsh environment, where the consequence of failure is severe and where the mode of possible failure can be difficult to establish with any degree of certainty.

Subsea equipment, once installed, most likely operates in a very benign environment. However, in some installations involving rotating machinery and/or large choke valves, the equipment can be exposed to long-term vibration and switching transients from high-voltage equipment. During transportation and installation handling, it is exposed to both shock and vibration. Typically, the equipment can be transported or stored onboard the installation rig or on a supply vessel for days and weeks. In this situation, it is exposed to vibration from diesel generators, etc. During less than ideal conditions, the equipment can be exposed to severe shocks.

This part of ISO 13628 shall apply for the following equipment:

- modules or sub-assemblies containing electrical and/or electronic equipment that are intended for permanent subsea installation;
- modules or sub-assemblies containing electrical and/or electronic equipment that are part of tools for maintenance of subsea installations.

This part of ISO 13628 outlines the minimum requirements for testing. Consideration shall be given to relevant testing not defined in this part of ISO 13628, e.g. thermal cycling during qualification testing and relative humidity testing.

Testing falls into the following two categories:

- a) qualification testing, which shall be performed on all models of equipment used for IWSs. The tests shall be carried out in accordance with E.5.1. It shall be verified that the various systems do not interfere with each other through EMC testing;
- b) ESS. All equipment supplied shall be subjected to ESS in accordance with E.5.2.

9 Materials and fabrication

9.1 General

All components used subsea shall be qualified, either by being field-proven or by qualification testing in simulated environments similar to the specific application.

9.2 Materials

9.2.1 Material selection

Materials selected for use in control system applications wetted by hydraulic fluid or chemicals shall be capable of being cleaned to a specified cleanliness level and maintained in an environment that provides that specified cleanliness level throughout the life of the system.

9.2.2 Corrosion considerations

Corrosion protection through material selection based upon a marine and process environment should consider, as a minimum, the following:

- external fluids;
- internal fluids;
- weldability;
- crevice corrosion;
- dissimilar metals effects;
- cathodic protection effects (including calcification in carbonate-rich environment and the impact of hydrogen-induced cracking failures such as stress corrosion cracking);
- the impact of breakdown of coatings due to damage and disbandment;
- bacterial effects;
- marine growth.

9.2.3 Fluid compatibility

All wetted surfaces shall be verified compatible with the wetting-control fluid, chemical-injection fluid, and/or well-bore fluids. Resilient seal materials shall be selected to ensure compatibility with wetting fluids, temperature and pressure.

9.3 Fabrication

9.3.1 Fittings and connections

PTFE tape shall not be used within any parts of the hydraulic system.

The same type (style) of fitting should be used for each pressure class throughout the system.

9.3.2 Welding

Structural-load-bearing welds shall be treated as non-pressure-containing welds and shall comply with a documented structural welding code such as AWS D1.1^[16].

All pressure-containing welds shall be in accordance with the ASME Boiler and Pressure Vessel Code, Section IX, ISO 15607, ISO 15609-2, ISO 15610, ISO 15611, ISO 15612, ISO 15613, ISO 15614-1 and ISO 15607.

NOTE 1 For the purposes of this provision, EN 288 (all parts)^[18] is the equivalent of ISO 15607.

Welders shall be qualified in accordance with ISO 9606-1, ISO 9606-2, or ASME Boiler and Pressure Vessel Code, Section IX.

NOTE 2 For the purposes of this provision, EN 287-1^[52] the equivalents of ISO 9606-1 and ISO 9606-2.

Brazing and soldering shall not be used for load-bearing systems.

9.3.3 Cleanliness

Hydraulic components shall be handled in accordance with the requirements of ISO/TR 10949. Equipment should be cleaned to the specified cleanliness standard prior to assembly. Flushing is not accepted as the primary means to achieve system and component cleanliness.

Consideration should be given to cleaning, pickling and passivating stainless steel hydraulic tubing to prevent corrosion.

9.3.4 Electrical and electronic assembly

For the subsea electronics, reliability of components should be established and should meet the specified life, free of failure.

10 Quality

Equipment manufactured according to this part of ISO 13628 shall conform to a certified quality assurance programme. The manufacturer shall develop written specifications that describe how the certified quality assurance programme is implemented.

11 Testing

11.1 General

All testing shall be performed with due consideration for the safety of personnel and potential damage to the surrounding area.

A comprehensive test programme should be undertaken to ensure that control system performance requirements are met.

Reference is made to Annex F for guidance on the selection of tests.

11.2 Qualification testing

11.2.1 Qualification test

Qualification tests shall be performed to confirm the performance of the equipment at its specified operating conditions and its compatibility with the electromagnetic environment. As an alternative to testing, the manufacturer may provide other objective evidence, consistent with documented industry practice, that the equipment will perform as specified.

In 11.2 is defined the qualification test procedures to be used to qualify product designs. Equipment or fixtures used to qualify designs should be representative of production models in terms of design, dimensions and materials and manufacturing process.

If a product design undergoes any changes in fit, form, function or material, the manufacturer shall document the impact of such changes on the performance of the product. A design that undergoes a substantive change becomes a new design requiring requalification.

NOTE A substantive change is a change identified by the manufacturer that affects the performance of the product in the intended service condition.

A change in material might not require requalification if the suitability can be substantiated by other means.

A qualification test for subsea electronic assemblies should be performed to qualify the design with respect to temperature cycling and vibration.

11.2.2 Hydrostatic pressure testing (internal and external)

As part of the qualification test, hydrostatic pressure tests shall be performed on all pressured components and/or assemblies. An internal hydrostatic pressure (proof pressure) test shall be performed at 1,5 times the design pressure for components rated at 103,4 MPa (15 000 psi) and below. Internal tests for components rated above 103,4 MPa (15 000 psi) shall be performed at 1,25 times the design pressure. External hydrostatic tests shall be performed at 1,1 times the design ambient pressure.

The test pressure shall be maintained for a minimum of 10 min without external fluid leakage from any component, line or joint.

All hydraulic accumulators shall be isolated from the circuit during the test.

The low-pressure portion of the control equipment, including, if applicable, the fluid reservoir, low-pressure filter, pump-feed lines and system-return lines, shall not be subjected to the hydrostatic test pressure (proof pressure).

11.2.3 Minimum and maximum temperature testing

Qualification tests shall be performed to confirm the performance of the equipment at a test temperature equal to or less than the minimum rated operating temperature classification, and at a test temperature equal to or greater than the maximum rated operating temperature classification.

11.2.4 Cycle testing

Equipment for which cyclic performance is an operational requirement shall be subjected to qualification testing which simulates long-term field service. The number of test cycles shall equal or exceed the number specified for the application.

11.2.5 Qualification testing of electrical and optical equipment

11.2.5.1 General

The qualification tests shall ensure that

- a) the equipment is robust and suitable for the environment to which it is exposed during transportation, handling, installation and operation;
- b) the exposure to the ESS test procedure does not cause any damage to or degradation of the equipment.

With regards to shock and vibration, the qualification tests shall be applied as follows:

- printed circuit boards and sub-assemblies shall be qualified to Q1 (see 11.2.5.2);
- electronic modules comprising one or more circuit boards assembled in a rack type frame shall be qualified to Q2 (see 11.2.5.2). Individual circuit boards in the electronic module do not require to undergo Q1 if the complete electronic module is qualified according to Q2.

The random vibration and thermal tests shall be made with the EUT powered and with full and continuous monitoring of all functions. To obtain such monitoring, special test equipment shall be made for connection to I/O circuits, etc. If the EUT is programmable (e.g. subsea electronic module) special test software within the EUT shall be made to ensure efficient and continuous monitoring of all parts of the EUT, ensuring a maximized probability of detection of intermittent faults even if the faults occur relatively infrequently and are of very short duration. Monitoring during sweeping for resonant frequencies is preferred, but may be omitted.

Operating temperature shall be demonstrated by calculations and tests at thermal conditions similar to the conditions the equipment is exposed to when installed subsea. The worst-case load conditions and thermal conditions shall be the basis for these calculations and tests.

Design and operating temperatures refer to the mean temperature of the ambient atmosphere within the enclosure in which the electronic or electrical system is operating.

This part of ISO 13628 outlines the minimum requirements for testing. Consideration shall be given to relevant testing not defined in this part of ISO 13628, e.g. thermal cycling during qualification testing and relative humidity testing.

11.2.5.2 Definition of qualification test Q1 and Q2

11.2.5.2.1 Shock tests

The EUT shall be mounted on the test fixture as it is mounted in normal service. If, in normal service, shock absorbers or vibration dampers are part of the mounting, these shall be part of the mounting also in these shock tests.

Four shocks shall be applied in each of six directions along three mutually perpendicular axes. The axes shall be selected to maximize the probability of detecting faults in the design. For printed circuit boards or equipment containing printed circuit boards, one of the axes shall be perpendicular to the plane of the board or majority of the boards, respectively. The shock level shall be as follows:

- Q1: 30 *g* acceleration, 11 ms half sine;
- Q2: 10 *g* acceleration, 11 ms half sine.

After the shock tests, no significant damage or distortion shall have occurred, and the object shall pass a 100 % functional test.

11.2.5.2.2 Vibration tests

The EUT shall be mounted on the test fixture as it is mounted in normal service. If, in normal service, shock absorbers or vibration dampers are part of the mounting, these shall be substituted by stiff structural members in this vibration test. Separate tests shall be performed to verify the functionality and quality of the shock absorbers/vibration dampers. This is also applicable for board guides with shock absorbers or vibration dampers.

The following excitation shall be applied to three mutually perpendicular axes. The axes shall be selected to maximize the probability of detecting faults in the design. For printed circuit boards or equipment containing printed circuit boards, one of the axes shall be perpendicular to the plane of the board or majority of the boards, respectively. The excitation level shall be as follows (as illustrated in Figure 2 below):

- Q1 and Q2: 5 Hz to 25 Hz with ± 2 mm displacement;
- Q1: 25 Hz to 1000 Hz with 5 *g* acceleration;
- Q2: 25 Hz to 150 Hz with 5 *g* acceleration.

The sweep rate is maximum one octave per minute. The sweep rate shall be low enough to allow any resonance to build-up amplitude.

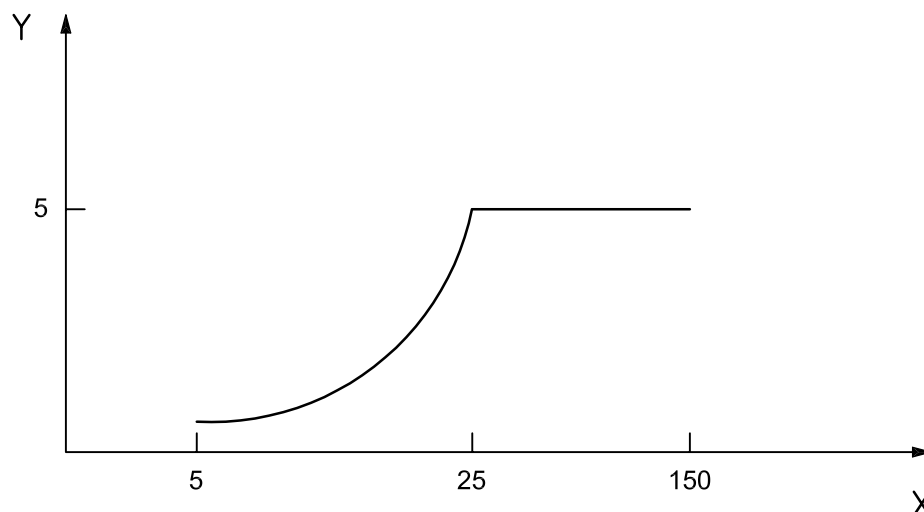
**Key**

- X log of the frequency, expressed in hertz
 Y acceleration, expressed in gravities

Figure 2 — Acceleration, g , over mechanical amplification frequency

NOTE Some vibration test equipment rigs have problems with large displacement amplitudes. Therefore the excitation is specified with constant amplitude (± 2 mm) in the region below 25 Hz as otherwise the displacement amplitude is prohibitively large for 5 g acceleration at these low frequencies. The maximum sweep rate is specified as 1 min per octave, i.e. 1 min minimum between each doubling of the frequency.

A double sweep from 5 Hz to 150 (Q2)/1 000(Q1) Hz and back to 5 Hz shall be performed. No resonance with mechanical amplification factor greater than 10 shall be observed in the range 5 Hz to 150 Hz for the EUT to pass the test.

If the EUT in its final use is exposed to significant vibration in the frequency range above 150 Hz (Q2) or 1 000 Hz (Q1), the frequency range in which the above resonance search is performed shall be extended to cover the applicable frequency range. The frequency range for the requirement of no resonance with mechanical amplification factor greater than 10 for the EUT to pass the test, shall be correspondingly expanded. The EUT shall then be exposed to a prolonged endurance test with random vibration as specified in 11.3.5.2. The testing shall be applied for 2 h.

After the vibration testing, no significant damage or distortion shall have occurred, and the EUT shall pass a 100 % functional test.

11.2.5.3 Temperature tests

With electrical power applied, and under full load, the EUT shall be temperature soaked for 48 h at the high design temperature. During this soak, periodic functional tests shall be made and no defects detected.

The same procedure shall be repeated for the low design temperature.

During the above temperature tests, reduced accuracy of measurement functions may be tolerated. However, such functions should perform as specified at the normal operating temperature as defined in above.

The tests shall be performed with forced circulation of air.

11.3 Factory acceptance tests (FAT)

11.3.1 General

Factory acceptance testing of the subsea control system elements shall be performed prior to delivery.

Step-by-step procedures with objectives and acceptance criteria shall be available prior to start of the FAT.

As a minimum, during the complete FAT, attention shall be paid to the following:

- electrohydraulic DCV performance and leak rates;
- accuracy of monitoring system;
- communication system sensitivity and noise immunity;
- electrical power requirements and sensitivities;
- pressure test of all tubing, pipework and hydraulic components;
- accumulator pre-charge pressure;
- relief-valve pressure setting;
- fluid and system cleanliness;
- pressure testing of control module;
- verification of equipment mating;
- electrical cable insulation resistance and conductance;
- leak-testing of applicable canisters;
- conductance to sacrificial anodes.

Environmental-stress screening for all subsea instruments and electronics shall be in accordance with manufacturer's written specification. For example, all SEMs can be required to pass a programme of temperature cycling, vibration and burn-in. The purpose of the temperature test is to verify that all components will function over the design temperature range, and to force possible premature ("infant mortality") component failures. The purpose of the vibration test is to reveal possible poor workmanship during assembly. All SEMs shall be leak-tested after final closure.

11.3.2 Integrity

Hydrostatic pressure testing shall be as specified in 11.2.2.

Components that may be excluded from this testing are those which have been tested and certified for use by an appropriate certifying body, e.g. American Bureau for Shipping, Det Norske Veritas. The hydrostatic test pressure (proof pressure) test shall be performed prior to installation of safety overpressure equipment.

11.3.3 Function and continuity

Functional tests shall be performed to demonstrate proper operation of the equipment. During the test, each hydraulic and electrical circuit shall be tested for proper operation.

Hydraulic circuits shall be tested at the design pressure of the circuit.

Electrical circuits shall be tested to ensure that there is no electrical short or open circuit.

Any circuit malfunction shall be reworked and retested to the above criteria prior to final acceptance.

11.3.4 Safety and operational checkouts

These tests are intended to verify that the system settings are in accordance with the design specifications and manufacturer's data sheets, using a checklist of all set points relating to pressure levels (regulators, relief valves, alarm and shutdown switches, accumulator pre-charge, pump start/stop switches), fluid levels, voltages, time delays, and similar parameters.

All safety features or devices shall be verified to operate correctly.

11.3.5 Environmental stress screening (ESS) of electrical and optical equipment

11.3.5.1 General

The purpose of this test is to disclose potential failures due to flaws in workmanship or components. The test shall be applied to all delivered items as part of, or in conjunction with, the FAT.

Individual boards may go through this test twice, i.e. at its FAT and as a part of an electronic module.

The entire test (vibration, thermal cycling and burn-in) shall be made with the EUT powered and with full and continuous monitoring of all functions. To obtain such monitoring, special test equipment shall be made for connection to I/O circuits, etc. If the EUT is programmable (e.g. subsea electronic module), special test software within the EUT shall be made to ensure efficient and continuous monitoring of all parts of the EUT, ensuring a maximized probability of detection of intermittent faults even if the faults occur relatively infrequent and are of very short duration.

The test apparatus shall ensure that the EUT under no circumstances is exposed to excessive humidity due to rapid changes of temperature.

The temperature cycling is performed by varying the temperature of the atmosphere in the test chamber. Circulation shall be provided to ensure a uniform temperature in the atmosphere. Heat radiation onto the EUT shall be avoided.

The ESS vibration shall be limited to a total of 10 min at the level specified so as not to over-stress the EUT. For diagnostic purposes during testing and fault-finding, the vibration level may be reduced if longer exposure times are required.

During the ESS vibration exposure, the EUT shall be mounted on the test fixture as it is mounted in normal service. If, in normal service, shock absorbers or vibration dampers are part of the mounting, these shall be substituted for the stiff structural members during the ESS vibration testing.

11.3.5.2 ESS test sequence

The following test sequence shall be applied:

Random vibration shall be applied along the axis during qualification testing identified as the highest stress axis for the EUT, normally the axis perpendicular to the planes of the majority of the printed circuit boards. If errors are detected, the excitation should be halted immediately and the fault located. If the application of vibration is required to locate the fault, this should be done at reduced amplitude.

The random vibration shall be applied for a total of 10 min, preferably divided into two 5-min segments before and after the thermal cycling.

The random vibration spectrum shall have the following characteristics (as illustrated in Figure 3 below):

EN ISO 13628-6:2006

- 20 Hz to 80 Hz at 3 dB per octave rise;
- 80 Hz to 350 Hz at $0,04 g^2/Hz$;
- 350 Hz to 2000 Hz at -3 dB per octave roll-off;
- composite excitation level shall be $6 g$ rms.

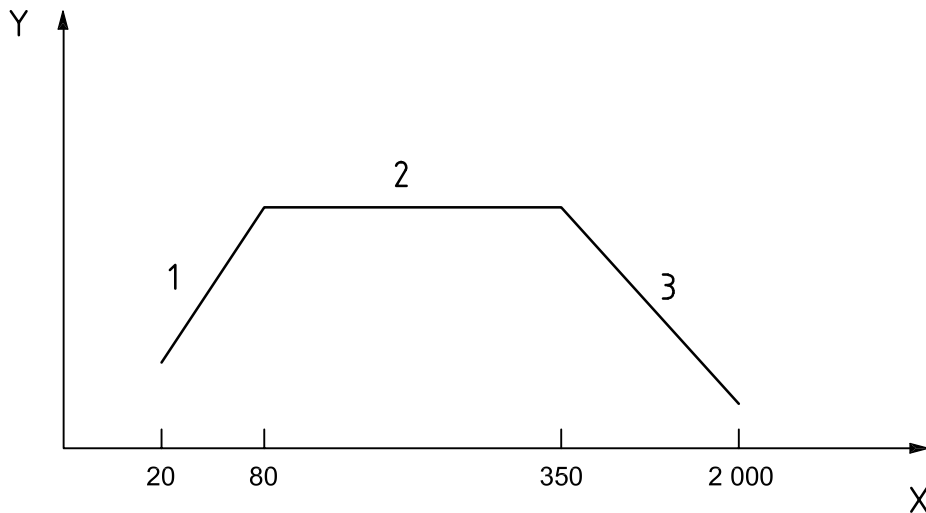

Key

- X log of the frequency, expressed in hertz
Y density, expressed in square gravities divided by the frequency
1 + 3 dB/octave
2 $0,04 g^2/Hz$
3 -3 dB/octave

Figure 3 — Energy density over frequency range

NOTE The random vibration is specified as spectral energy density over a frequency range. The integral of the density profile is a measure of the total energy (or load on the equipment). The integral of the above curve is approximately $6 g$ rms.

The above spectrum may be modified by the introduction of notches if resonances of the EUT result in intolerable vibration loads on individual components. The composite excitation level shall still be $6 g$ rms. Modification of the above spectrum shall not be performed without documenting and evaluating frequency spectrum of the specific application.

Ten thermal cycles shall be applied. The temperature limits for the temperature cycling shall be the maximum and minimum design temperatures. If faults are detected during thermal cycling, these shall be repaired according to approved methods, and the sequence started over. After ten cycles of no failures, the test has been passed. One thermal cycle shall be performed as follows.

- Increase to high design temperature at minimum $5 ^\circ C/min$ ($9 ^\circ F/min$).
- Keep at this temperature for a minimum of 30 min.
- Decrease to low design temperature at minimum $5 ^\circ C/min$ ($9 ^\circ F/min$).
- Keep at this temperature for a minimum of 30 min.

The test shall be ended with a 48 h burn-in at the high design temperature under full load conditions.

The temperature tests shall be performed with forced circulation of air.

The tested item shall undergo a 100 % functional test after the burn-in.

11.3.6 Other testing which may be required by the purchaser

11.3.6.1 Internal leakage testing

The purpose of leak-testing is to verify that internal system leakage is within acceptable limits in accordance with manufacturer's written specifications. The test shall be performed at the design pressure of the hydraulic control system, with all circuits being tested. The minimum duration for testing shall be 10 min. Leakage rate shall be monitored by either

- pressurizing the system to design pressure, isolating the source of supply and monitoring pressure decay. Pressure decay shall be monitored and recorded;
- applying a constant pressure source to the system and monitoring the leakage rate of the various system components.

11.3.6.2 Fluid flushing

The purpose of the fluid flushing is to remove any contamination that might have been introduced into the hydraulic system during fabrication. The fluid flushing should be carried out using the specified system operating fluid.

11.3.6.3 Sensitivity testing

Sensitivity testing may be performed on subsystems or the complete production control system.

The purpose of this testing is to vary key parameters in a controlled manner while monitoring system performance and limits of operation.

11.4 Integrated system tests

An integrated system test may be performed. If practical, process equipment, subsea hardware and controls should be tested together before installation. These tests are typically performed at a shore base to facilitate modifications and rework that may be necessary.

Integrated system tests should be carried out for all modes of operation and, if applicable, in fully redundant and non-redundant configurations. Separate tests should be conducted for minimum, normal and maximum loadings.

Integrated system tests typically include end devices and interconnecting jumpers, umbilicals, stabplates, as well as the non-control system components to which they interface, and any running tools that are used during installation. Function tests verify the final result of all input signals, overrides and resets. Key set points should be rechecked. A primary benefit during integrated testing is the familiarization of operating personnel with the location of the adjustable devices and the methods used to verify or change the set points.

In addition, performance tests should record actuation times for actuators, accumulator bank discharge volumes, recovery times for pumping systems, power consumption for electrical circuits, delivery rates for chemical injection circuits, expansion volumes for long hoses, and the accuracy of readback monitors.

Reference should be made to ISO 13628-1^[6] for additional discussion on system testing.

11.5 Documentation

The manufacturer shall document the procedures used and the results of all performance verification tests and FATs. The documentation should identify the person(s) conducting and witnessing the tests, and the time and place of the testing.

12 Marking, packaging, storage and shipping

12.1 Marking

12.1.1 Component identification

All major components (e.g. HPU, SCMs, MCS, EPU, etc.) shall be marked by an identifying tag, name plate, or imprinted identification. The identifying means shall be suitable for the environment and shall include appropriate information such as an identifying manufacturer's number, input utilities ratings, equipment design pressure (rated working pressure), and date of manufacture.

12.1.2 Surface and subsea equipment temperature ratings

Surface and subsea equipment shall be permanently marked as follows:

a) standard operating temperature:

EXAMPLE Low-temperature rating of 0 °C (32 °F) and high-temperature rating of 40 °C (104 °F)

Stamp: 0 °C to 40 °C (32 °F to 104 °F) standard.

b) extended operating temperature:

EXAMPLE Low-temperature rating of – 5 °C (23 °F) and high-temperature rating of 40 °C (104 °F)

Stamp: – 5 °C to 40 °C (23 °F to 104 °F) extended.

12.1.3 Special marking — Usage restricted to controlled environment

Surface-installed equipment that is designed to operate in a controlled environment shall be labelled with a blue and white label warning the user to be aware of the environmental usage restrictions to be found in the operator's manual. The label shall have the following format:

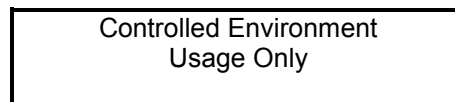

12.2 Packaging

12.2.1 Rust prevention

Prior to shipment, parts and equipment shall have exposed metallic surfaces (except corrosion-resistant materials and special items such as anodes or nameplates) either protected with a rust-preventive coating that does not become fluid at temperatures of less than 50 °C (125 °F), or that is filled with a compatible fluid containing suitable corrosion inhibitors in accordance with the manufacturer's written specification. Equipment already coated, but showing damage after testing, should undergo coating repair in accordance with the manufacturer's written specification.

12.2.2 Surface protection for seals

Exposed seals and seal surfaces, threads and operating parts shall be protected from mechanical damage during shipping. Flange faces, clamp hubs and other vulnerable parts shall be protected by suitable covers or other protective devices. Shipping skids or containers should be designed such that equipment does not rest on any seal or seal surface during shipment or storage.

12.2.3 Loose components

Loose components shall be separately packaged and identified as specified in 12.1.

12.3 Storage and shipping

12.3.1 Elastomer age control

The manufacturer shall document instructions concerning the proper storage environment, age control procedures, and protection of elastomeric materials.

12.3.2 Hydraulic and pneumatic systems

12.3.2.1 General

Prior to shipment, hydraulic lines shall be flushed, filled and/or drained in accordance with the manufacturer's written specification. Exposed hydraulic end fittings shall be capped or covered. Follow the instructions in 12.3.2.2 to 12.3.2.5.

12.3.2.2 Pressurized circuits

Bleed all gas and pressurized hydraulic circuits to zero gauge pressure.

12.3.2.3 Accumulators

Bleed the gas pre-charge of all accumulators to zero gauge pressure.

12.3.2.4 Fluid reservoir

Drain the hydraulic control fluid from the reservoir.

12.3.2.5 HPU fluid and electrical connections

Disconnect all inlet and outlet connections. Cap all connections with protection covers.

12.3.3 Electrical/electronic systems

The manufacturer shall document instructions concerning proper storage and shipping of all electrical cables, connectors, and electronic packages, e.g. SCM, MCS, etc.

12.3.4 Crating and handling

For shipment, units and assemblies should be securely crated or mounted on skids to prevent damage and to facilitate sling handling.

Protective packing material should be fixed in place over all outside mounted panel gauges to protect them from damage.

12.3.5 Shipping and storage temperature limitations

For shipping and storage, control system equipment should be designed and prepared to allow for the maximum expected temperature range. The fluid compensation systems may need to be replenished after exposure to high temperatures and/or transportation.

Annex A (informative)

Types and selection of control system

A.1 System selection

Factors that affect control system selection are cost (including whole life-cycle estimates that include cost of maintenance and lost production caused by control system failures), offset distance from the host, response-time requirements, and data telemetry requirements.

All-hydraulic systems are generally the least complicated and the most reliable subsea control systems. They are relatively slow to respond, compared to electrohydraulic systems, and have limited capability for providing data telemetry from the subsea system. The specific needs of each application should be carefully considered, particularly with respect to data needs and speed of response, before selecting an all-hydraulic system approach. Project economics dictate whether to choose an all-hydraulic or electrohydraulic system: all-hydraulic systems are generally preferred for single satellite wells located relatively close to the host facility, and where project economics require minimum cost.

Electrohydraulic systems have the added complexity of subsea electronics and electrical devices, but offer much faster response time and have the capability to monitor a wide range of data-telemetry devices. Electrohydraulic systems are typically preferred for multi-well developments where operating flexibility, speed of operation and data telemetry is needed for well control and/or reservoir monitoring.

A.2 All-hydraulic system descriptions

A.2.1 General

The three types of all-hydraulic systems are defined below. A choice among these three system approaches should consider the system response-time needs and umbilical requirements.

A.2.2 Direct hydraulic systems

For direct hydraulic systems, a separate hydraulic line is provided for each function, connected directly to the valve actuator, pressure-sensing point or other subsea function to be controlled. No subsea control equipment is required, other than an umbilical connector and routing of control lines to each function.

A.2.3 Piloted hydraulic systems

Piloted hydraulic systems include a subsea control module containing pilot valves, along with a local subsea source of hydraulic power, generally accumulators which are charged through a separate line from the surface. The signal lines are required to provide only enough fluid to shift one of the small pilot valves, and the fluid to actuate tree or manifold valves is provided locally from the subsea accumulators. This type of system extends the allowable distance between the subsea system and the host, compared to a direct hydraulic system, by minimizing the valve actuation time.

A.2.4 Sequential hydraulic systems

Sequential hydraulic systems also use control modules with special pilot valves which do not require a separate line for each function. An increasing sequence of hydraulic pressure steps on a single pilot line common to all pilot valves in a module causes activation of different pilot valves at each pressure level to control subsea valves, using power fluid from subsea accumulators. The number of hydraulic lines is minimized, since only one pilot line per tree is needed. The disadvantage of this approach is that the opening

sequence of subsea valves is predetermined, with no flexibility for operating valves in a different sequence. This type of system has most commonly been used as a backup to an electrohydraulic system, but has also been used as an independent system to reduce the umbilical requirements and cost.

A.3 Electrohydraulic systems

A.3.1 General

Electrohydraulic control systems replace hydraulic signals with electric signals, which essentially eliminate the signal-time portion of response time. They also add the capability of monitoring a much wider variety of subsea data.

An electrohydraulic control system requires an additional electrical control umbilical, or the inclusion of electrical cables within the hydraulic control/chemical-injection umbilical. However, the hydraulic components requirements in the umbilical are decreased, compared to direct and piloted hydraulic systems, since only system hydraulic supply and chemical injection conduits are needed.

A.3.2 Direct electrohydraulic systems

Direct electrohydraulic systems transmit signals through multiple individual conductors in the control umbilical directly to solenoids on DCVs located in the subsea modules. This system option increases cost of the umbilical and is sensitive to power losses in the multiple conductors as offset distance from the host facility increases. The umbilical requirements increase in direct proportion to the number of wells controlled.

A.3.3 Multiplexed electrohydraulic systems

Multiplexed electrohydraulic systems transmit electrical signals to one or more subsea SEMs by means of coded, digital messages via a single pair of conductors (or optical fibre). The SEM decodes the message and takes the appropriate action, such as valve actuation or query of a subsea sensor. A single umbilical can communicate with all the wells in a subsea development, thus minimizing umbilical control component requirements. Power requirements for signals are low, since power for solenoid actuation is provided through a separate, power function. Communication and power can be via separate conductor (or optical fibre) pairs, or communications signals can be superimposed on the power conductors, minimizing the total number of conductors in the umbilical.

A.3.4 Autonomous systems

Autonomous systems provide locally generated power and control to the subsea production facility. Hydraulic fluid is locally stored. Communication with the surface facility may be via an acoustic link or via a combination of acoustic/satellite/radio links. The basic system functions are the same as for a multiplexed electrohydraulic system.

A.4 Electrical systems

A.4.1 General

Electric control systems use only electric signals, which essentially eliminate the signal-time portion of response time, improves ESD response and eliminates water depth induced efficiency reductions and limitations of subsea accumulators. They also improve the capability of monitoring of subsea data and equipment data (e.g., such as actuator operating characteristics over time). An electric control system requires an electrical control umbilical, or the inclusion of electrical cables within the chemical-injection umbilical. However, the hydraulic components requirements in the umbilical are greatly decreased compared to hydraulic and multiplexed electrohydraulic systems, since only system chemical injection conduits are needed. The chemical injection conduits can be installed alongside production/injection flow lines, which enables an electric-only controls umbilical.

A.4.2 Direct electric system

Direct electric systems transmit signals through multiple individual conductors in the control umbilical directly to control components and valve operator actuators located in the subsea modules and on the subsea tree/manifold/other structure. This system option increases cost of the umbilical and is sensitive to power losses in the multiple conductors as offset distance from the host facility increases. The umbilical requirements increase in direct proportion to the number of wells controlled.

A.4.3 Multiplexed electric system

Multiplexed electric systems transmit electrical signals to one or more subsea SEMs by means of coded, digital messages via a single pair of electrical conductors (or optical fibres). The SEM decodes the message and takes the appropriate action, such as valve actuation or query of a subsea sensor. A single umbilical can communicate with all the wells in a subsea development, thus minimizing umbilical control component requirements. Power requirements for signals are low, since power for control components and valve operator actuation is provided through a separate, power function. Communication and power can be via separate conductor pairs (or optical fibres), or communications signals can be superimposed on the power conductors, minimizing the total number of conductors in the umbilical.

A.4.4 Autonomous electric system

Autonomous systems provide locally generated power and control to the subsea production facility. Chemical injection fluid is locally stored, or provided from a dedicated chemicals umbilical/flow line. Communication with the surface facility may be via an acoustic link or via a combination of acoustic/satellite/radio links. The basic system functions are the same as for a multiplexed electric system.

A.5 Hydraulic system layout

Hydraulic systems should be looped to exhaust control fluid to sea (for open systems) or to the umbilical return line (for closed systems) during the opening stroke. This system has inherent safety features:

- process valves can close in the event of return line or exhaust valve blockage;
- reflected pressures in the return line will not cause closed process valves to open;
- the seachest/compensator is always topped up when the gate valve actuators are stroked to open the process valve.

Annex B (informative)

Typical control and monitoring functions

B.1 Control functions

A typical list of valves controlled by the subsea control system is as follows:

- SCSSVs;
- production master valve;
- production wing valve;
- annulus master valve;
- annulus wing valve;
- crossover (injection) valve;
- methanol/chemical injection valve;
- scale-inhibitor injection valve;
- corrosion-inhibitor injection valve;
- production choke valve (can require two control functions per choke);
- injection choke valve (can require two control functions per choke);
- manifold valve(s);
- chemical-injection control valve.

B.2 Monitoring functions

A typical list of parameters typically monitored by subsea-located sensors of a subsea control system is as follows:

- production pressure;
- choke downstream pressure;
- annulus pressure;
- manifold pressure;
- production temperature;
- manifold temperature;
- hydrocarbon leak detection;

- tree valve position (direct or inferred);
- production choke position;
- production choke differential pressure;
- sand detection;
- downhole monitoring;
- multiphase flow;
- corrosion monitoring;
- pig detection.

B.3 Subsea control module (SCM) parameter monitoring

The following subsea parameters may be monitored inside the SCM:

- hydraulic supply pressures;
- communication status;
- internal voltages in SEM;
- internal temperature in SEM;
- internal pressure in SEM;
- self-diagnostic parameters;
- hydraulic fluid flow;
- hydraulic return pressure;
- insulation resistance.

Consideration should be given to self-diagnostics to detect malfunctions for external sensor systems connected to the control module, e.g. downhole monitoring, multiphase-flow meters, and sand detectors. The control system should be capable of performing specific diagnostics in case of a malfunction in a sensor system.

Annex C (informative)

Properties and testing of control fluids

C.1 Property requirements of control fluids

Fluid property requirements for both water/glycol-based and oil-based fluids are described below.

Qualification tests shall be performed by the fluid manufacturer in order to qualify a fluid formulation under this part of ISO 13628. The fluid being tested shall meet or exceed all acceptance criteria in order to qualify.

C.2 Properties and testing of water/glycol-based control fluids

C.2.1 Test specifications

It is a general requirement that all test fluid shall be pre-filtered before the testing starts. Either in a dynamic test rig where the minimum accumulated filtered volume is seven times the reservoir volume of the rig, or single pass through a Millipore membrane¹⁾ (or similar). The filtration ratio, β , of the dynamic test rig filter shall be equal to or greater than 200 at 5 μm . The single-pass Millipore type filter shall have a filtration rating of 1,2 μm .

C.2.2 Stability, compatibility, filterability, lubricity and wear

C.2.2.1 Thermal stability — High temperature

C.2.2.1.1 General

This test shall be performed whenever the control system operating fluid is intended for service above 80 °C (176 °F).

C.2.2.1.2 Methods and measurements

The neat fluid is exposed at the maximum temperature specified by the fluid supplier plus a safety margin of + 10 °C (+ 18 °F), or at the maximum operational temperature for a specific subsea project plus the same safety margin.

Fluid is exposed for up to 12 months. The approval can be issued after 6 months, but the test shall continue through to 12 months to verify the 6 months result.

Visual inspection of fluid and solids formed, pH, viscosity, lubricity, and final fluid volume are all measurements used to validate the thermal stability.

C.2.2.1.3 Procedure

All fluids used for flushing and cleaning in this procedures shall be filtered and dispensed through an in-line nominal 0,8 μm pore size filter.

1) A Millipore membrane is an example of a suitable product available commercially. This information is given for the convenience of users of this part of ISO 13628 and does not constitute an endorsement by ISO of this product.

The following procedure shall be followed.

- a) Select aging vessels that
 - are of 316 or better quality stainless steel wetted components,
 - have a full-opening top to permit “straight through” cleaning and inspection.
- b) Clean the three test vessels in accordance with ISO 3722 and for the final rinse use either filtered de-ionized water for water-based fluids or filtered petroleum spirit for oil-based fluids.
- c) Let the vessels dry in a clean lint-free environment. Do not use an air line to dry the vessels, as this introduces contamination. Test for vessel cleanliness by filling with 150 ml (9,15 in³) de-ionized water (petroleum spirit for oil-based fluid test), agitate, and then count particles. The acceptance criterion is less than 200 particles greater than 5 µm per 100 ml (6,1 in³) of fluid volume.
- d) Fill vessels with 400 ml ± 5 ml (24,4 in³ ± 0,3 in³) of the control fluid.
- e) Purge the air space above the control fluid with dry filtered nitrogen and regulate the pressure to a value sufficient to prevent boiling of the control fluid. Maintain this pressure throughout the test.
- f) Heat the vessels to the desired temperature and maintain ± 1% throughout the test.

A minimum of three 400 ml (24,4 in³) fluid samples are exposed for 2 months, 6 months and 12 months, in a separate vessel for each period. After testing the whole content of the vessels is retrieved. This includes the liquid as well as any solids which may have collected at the bottom or walls and cover of the vessel. After retrieval of the sample from the autoclave, any solids are collected, dried and weighed to the nearest mg. A volume of 200 ml (12,2 in³) from each sample is reserved for the low-temperature stability testing, see C.2.2.2.

The appropriate measurements are carried out and changes relative to the unused fluid are calculated. To avoid changes in the fluid properties after the vessel has been opened, the pH-measurements and visual observations are done within 8 h after opening of the vessel.

Test for fluid lubricity and wear (see C.2.2.12) before and after exposure to the maximum temperature.

C.2.2.1.4 Results

The following results shall be noted:

- a) change in appearance relative to unused fluid;
- b) qualitative description of separation in the fluid in the form of a secondary liquid phase or solid matter (particles, sludge);
- c) amount (mass) of total solid matter formed;
- d) pH-value and lubricity as a function of time;
- e) viscosity at the end of test;
- f) volume change during test (loss of water).

C.2.2.1.5 Acceptance criteria

The acceptance criteria are as follows.

- a) visual appearance: The fluid shall not change significantly in appearance. Fading of the initial colour is acceptable.
- b) fluid separation: No secondary liquid phase and no substantial amount of particles/sludge shall form in the fluid. Maximum content of collected solids (deposits) shall not exceed 10 mg/l of fluid.
- c) pH-value: The time development of the pH-value measured at the three test periods shall be considered, and it shall show a clear tendency to stabilization over the total of 12 mo. Maximum reduction or increase in pH shall be 0,8 units.
- d) lubricity: Lubricity shall not change by more than 10 % relative to the original value and it should stabilize during the test.
- e) viscosity: The viscosity shall not change by more than 10 %.
- f) fluid volume: The retrieved volume of the fluid shall be at least 99 % of the original volume.

C.2.2.2 Thermal stability — Low temperature

C.2.2.2.1 Methods and measurements

The neat fluid and fluid samples retrieved from the high-temperature testing are exposed for 4 wk. The appearance of the fluid is observed.

C.2.2.2.2 Procedure

The fluid is left undisturbed for 4 wk at + 5 °C (+ 41 °F) and at the minimum recommended temperature, but not lower than – 10 °C (+ 14 °F). At the end of exposure the fluid is inspected (by naked eye) with respect to changes in appearance including formation of liquid or solid separation.

C.2.2.2.3 Results

The following results shall be noted:

- a) change in appearance relative to unused fluid;
- b) qualitative description of separation in the fluid in the form of a secondary liquid phase or solid matter (particles, sludge).

C.2.2.2.4 Acceptance criteria

The acceptance criteria are as follows.

- a) The fluid shall not change in appearance.
- b) No secondary phase liquid or solid particles/sludge shall be visible at the end of the test.

C.2.2.3 Thermal stability — High temperature in the presence of seawater

The fluid is mixed with 10 % artificial seawater according to ASTM D1141 and tested as described for the thermal stability of the neat fluid at high temperature, see C.2.2.1. Methods, procedures and acceptance criteria are in all respects identical to C.2.2.1.

C.2.2.4 Seawater compatibility

C.2.2.4.1 Methods and measurements

For high temperatures, this property is covered by the thermal stability in the presence of seawater test; see C.2.2.3.

Fluid-seawater mixtures are exposed for 4 wk at low 5 °C (41 °F), ambient 20 °C (68 °F), and moderate 70 °C (158 °F) temperatures.

The following methods are used:

- visual inspection;
- filtering off and collection of solids formed in the fluid;
- pH-measurement.

C.2.2.4.2 Procedure

The fluid is mixed with 5 %, 10 % and in steps of 10 % up to 50 % artificial seawater, see ASTM D1141. The pH-value of each mixture is measured. The mixtures are then exposed at 5 °C (41 °F), 20 °C (68 °F) and 70 °C (158 °F) for 4 wk. The appearance of the fluid is observed and compared with the neat fluid, any solid matter is filtered off and the final pH-values are measured.

C.2.2.4.3 Results

The following results shall be noted:

- a) change in appearance relative to unused fluid;
- b) qualitative description of separation in the fluid in the form of secondary liquid phase or solid matter (particles, sludge);
- c) pH-value of fluid mixtures before and after exposure.

The results (appearance and pH) at > 10 % seawater and up to 50 % are recorded as supplementary information, giving an approximate threshold value for the compatibility. A threshold value above 10 % is not related to an acceptance criterion.

C.2.2.4.4 Acceptance criteria

The acceptance criteria are as follows.

- a) No changes in appearance and no separation at 5 % and 10 % seawater over the test period.
- b) The pH-value shall not drop by more than 0,2 units due to mixing with 5 % and 10 % seawater and it shall not change by more than further 0,2 units during the test.

C.2.2.5 Control fluid compatibility

C.2.2.5.1 Methods and measurements

The primary fluid is mixed with the reference control fluids in specified mixing ratios at ambient and moderate temperatures for 4 wk. Reference fluids²⁾: Transaqua HT, Oceanic HW 443, Oceanic HW 540 and Aqualink 300.

The following methods are used:

- a) visual inspection;
- b) filtering off and collection of solids formed in the fluid;
- c) pH-measurement.

C.2.2.5.2 Procedure

The primary fluid is mixed with the reference control fluid in the mixing ratios by volume: 90:10, 75:25, 50:50, 25:75 and 10:90. The samples are exposed undisturbed at 5 °C (41 °F), 20 °C (68 °F) and 70 °C (158 °F) for 4 wk and the appearance is observed. The pH-value of each mixture is measured before and after exposure.

C.2.2.5.3 Results

The following results shall be noted:

- a) change in appearance relative to the single fluids and unexposed mixtures;
- b) qualitative description of separation in the fluid in the form of a secondary liquid phase or solid matter (particles, sludge);
- c) pH-value of fluid mixtures before and after exposure.

C.2.2.5.4 Acceptance criteria

The acceptance criteria are as follows.

- a) No change in appearance except natural colour changes if the fluids are of different colours, at any mixing ratio.
- b) No separation at any mixing ratios.
- c) The pH-value shall not change by more than $\pm 0,2$ units relative to the initial pH of a given mixture during the test.

C.2.2.5.5 Optional test

The test does not cover high temperature or other performance testing of the fluid mixtures. Optional tests carried out on request may be comprised of the thermal stability (see C.2.2.1), and thermal stability for 50:50 volume mixing ratios in addition to the metal and the elastomer compatibility tests at maximum temperature. The maximum temperature of a mixture is governed by the lower maximum temperature of the neat fluids.

2) Transaqua HT, Oceanic HW 443, Oceanic HW 540 and Aqualink 300 are examples of suitable products available commercially. This information is given for the convenience of users of this part of ISO 13628 and does not constitute an endorsement by ISO of these products.

C.2.2.6 Completion fluid compatibility

C.2.2.6.1 Methods and measurements

The control fluid is mixed with specific completion fluids in defined mixing ratios at 5 °C (41 °F) and 20 °C (68 °F) and exposed undisturbed for 4 wk.

The following methods are used:

visual inspection;
pH-measurement.

C.2.2.6.2 Procedure

The control fluid is mixed with the following completion fluids in the volume mixing ratios: 99,5:0,5, 99:1, 98:2, 95:5, and 90:10 for the compounds calcium chloride (CaCl_2), calcium bromide (CaBr_2), zinc bromide (ZnBr_2), potassium formate (K-formate) and caesium formate (Cs-formate). The actual brines shall be selected from commercially available products, and the type, brand and other relevant data shall be included in the report.

The samples are exposed undisturbed at 5 °C (41 °F) and 20 °C (68 °F) for 4 wk. The appearance of the mixtures and formation of separation are observed instantly after mixing, after 1 h, 1 day, 1 wk and 4 wk. The pH-value of each mixture is measured before and after exposure and compared with the pH of the pure control fluid.

C.2.2.6.3 Results

The following results shall be noted:

- a) change in appearance relative to pure control fluid and unexposed mixtures;
- b) qualitative description of separation in the fluid mixtures in the form of a secondary liquid phase or solid matter (particles, sludge, plug);
- c) pH-value of fluid mixtures before and after exposure.

C.2.2.6.4 Acceptance criteria

There are no general acceptance criteria related to this property. The results have to be evaluated for the individual projects for which they are relevant. It is up to each specific project to define project-related criteria if this is considered necessary.

C.2.2.7 Compatibility with miscellaneous operational fluids

C.2.2.7.1 Methods and measurements

The control fluid is mixed with other relevant operational fluids: wellbore acids, methanol or compensation fluid [Elf Nemis SN³], silicon or insulating oil in the specified volume mixing ratios at 5 °C (41 °F), and 20 °C (68 °F) and exposed undisturbed for 4 wk.

The following methods are used:

- a) visual inspection;
- b) pH-measurement.

3) Elf Nemis SN is an example of a suitable product available commercially. This information is given for the convenience of users of this part of ISO 13628 and does not constitute an endorsement by ISO of this product.

C.2.2.7.2 Procedure

The control fluid is mixed with the operational fluid in a mixing ratio which depends on the secondary fluid, 35 % hydrochloric acid, in the following volume mixing ratios: 99,5:0,5; 99:1; 98:2; 95:5 and 90:10.

- a) for methanol: 95:5; 90:10; 75:25 and 50:50;
- b) for compensation fluids: 95:5; 90:10; 75:25 and 50:50.

The samples are exposed undisturbed at 5 °C (41 °F), and 20 °C (68 °F) for 4 wk. The appearance of the mixtures and formation of separations are observed instantly after mixing, after 1 h, 1 d, 1 wk and 4 wk. The pH-value of each mixture is measured before and after exposure and compared with the pH of the neat control fluid.

C.2.2.7.3 Results

The following results shall be noted:

- a) change in appearance relative to neat fluid and unexposed mixtures;
- b) qualitative description of separations in the fluid in the form of secondary liquid phase or solid matter (particles, sludge);
- c) pH-value of fluid mixtures before and after exposure.

C.2.2.7.4 Acceptance criteria

There are no general acceptance criteria related to this property. The results have to be evaluated for the individual projects for which they are relevant. It is up to each specific project to define project-related criteria if this is considered necessary.

C.2.2.8 Metal compatibility

C.2.2.8.1 General

This test is not a material qualification but a fluid qualification test.

C.2.2.8.2 Methods and measurements

Tests are carried out in the neat fluid and in the fluid with 10 % artificial seawater. There are two different test set-ups and procedures, one for ambient 20 °C (68 °F) and moderate 60 °C (140 °F) temperatures and a second for high temperatures.

A set of standard test materials shall be used; see C.2.4.2. The samples are designed in such a manner that edge effects are minimized. Ready-made samples with reproducible crevices (where required) are provided by a commissioned supplier.

The following standard test materials and samples are used:

- Tests at 20 °C (68 °F), and 60 °C (140 °F): Carbon steel EN 10025^[42] Grade S235, Al-bronze grade SAE701D, AISI 440 with and without crevice, tungsten carbide with 10 % Ni binder, beryllium copper UNS C17200, AISI 440 bolt and nut on AISI 316 plate (area ratio 1:10), carbon steel EN 10025^[42] Grade S235 bolt and nut on AISI 316 plate (area ratio 1:10), AISI 316 with and without crevice and 17-4 PH with and without crevice.
- Test at high temperature: AISI 316 with and without crevice and 17-4 PH with and without crevice.

The following methods are used:

- a) visual inspection (appearance, separations, deposits);
- b) filtering off, collection and weighing of solids formed in the fluid;
- c) pH-measurement;
- d) mass loss of metal samples;
- e) inspection and characterization of corrosion products and corrosion attacks; see ASTM G1.

C.2.2.8.3 Procedure

Samples of the neat fluid and fluid which has been mixed with 10 % artificial seawater (see ASTM D1141) are used. The ready-made metal samples, which have a standard surface area and a standard surface condition, are degreased, dried and weighed to the nearest 0,1 mg. Further procedure is as given in a) and b) below.

- a) Tests at 20 °C (68 °F) and 60 °C (140 °F) are carried out in glass vessels that are not sealed but covered to avoid significant evaporation of water from the fluid. Each of the individual metals and galvanic couplings (see list above) is exposed in a separate container in a number of nine replicate specimens. Three replicates are retrieved from the fluid after 3 wk, 6 wk and 12 wk. After visual inspection of the samples and after appropriate cleaning, weight loss is measured and the samples inspected for visible corrosion attacks, which are characterized. The weight losses are transcribed into uniform corrosion, in micrometres per year, and maximum depth of local attacks, in micrometres, is determined under a microscope with a calibrated depth of focus. The fluid is inspected for any separations, including solid particles or sludge, which are filtered off and weighed together with deposits collected from the metal samples.
- b) Test at maximum temperature plus 10 °C (18 °F) is carried out in a suitable autoclave made of AISI 316 or better quality material, pressurised to an appropriate level to prevent boiling (depends on the test temperature). The various samples (for AISI 316 and AISI 17-4 PH, both with and without crevice) are exposed together in triplicate for each testing period. The test is run for 2 months, 6 months and 12 months in a separate vessel for each testing period. At the termination of the test the same procedure as in C.2.2.8.3 a) is followed. The results are reported for approval after six months.

C.2.2.8.4 Results

The following results shall be noted:

- a) change in appearance of fluid relative to unused fluid;
- b) pH-value of fluid as a function of time;
- c) appearance and amount of solid deposits (particles, sludge) in the fluid and on the metal samples;
- d) qualitative description of corrosion products and corrosion attacks (attacks which are clearly related to edges or fixture holes are disregarded);
- e) mass loss as a function of time, transformed into micrometres per year uniform corrosion;
- f) extent and depth of local attacks as a function of time including maximum depth of local attacks (pitting, crevice corrosion).

C.2.2.8.5 Acceptance criteria

The same criteria apply to the neat fluid and the fluid with 10 % artificial seawater:

a) general criteria:

- no substantial visible corrosion products or attacks on any of the metals,
- no significant amounts of deposits (particles or sludge) in the fluid at the end of the test period,
- corrosion rates shall show a clear declining tendency with time.

b) specific criteria for the high-temperature test:

- Corrosion rate of AISI 316 shall not exceed 10 µm/year (6 months result) and maximum depth of local attacks shall not exceed 25 µm.
- Corrosion rate of 17-4 PH shall not exceed 20 µm/year and maximum depth of local attacks shall not exceed 50 µm.

c) specific criteria for the ambient and moderate temperature tests:

- Corrosion rate of the carbon steel including galvanic coupling shall not exceed 20 µm/year (1 year result).
- Corrosion rate of all other materials shall not exceed 10 µm/year (6 months result) and maximum depth of local attacks shall not exceed 20 µm.

C.2.2.8.6 Optional test

If the fluid is sold as containing a vapour phase inhibitor, it should be tested as follows.

Carbon steel EN 10025^[42] Grade S235 samples are exposed in the air space above the fluid exposed at 60 °C (140 °F) in the above test set up. Samples are removed after 16 h and inspected visually for rust stains. Acceptance criterion is no rust stains during the test.

C.2.2.9 Elastomer compatibility

C.2.2.9.1 Methods and measurements

Tests are carried out in the neat fluid at a moderate [70 °C (158 °F)] and high temperature [maximum plus 10 °C (18 °F)], respectively. Standard test materials are used, the type depending on the temperature:

- At 70 °C (158 °F): HNBR 70⁴⁾, Viton 70⁵⁾, NBR (natural buna rubber) 70⁶⁾.
- At high temperature: PTFE, polyether-ether-ketone, Chemraz⁷⁾ and HNBR 70 [up to 120 °C (248 °F)].

4) HNBR 70 is an example of a suitable product available commercially. This information is given for the convenience of users of this International Standard and does not constitute an endorsement by ISO of this product.

5) Viton 70 is an example of a suitable product available commercially. This information is given for the convenience of users of this part of ISO 13628 and does not constitute an endorsement by ISO of this product.

6) NBR 70 is an example of a suitable product available commercially. This information is given for the convenience of users of this International Standard and does not constitute an endorsement by ISO of this product.

7) Chemraz is an example of a suitable product available commercially. This information is given for the convenience of users of this part of ISO 13628 and does not constitute an endorsement by ISO of this product.

The following methods are used:

- a) visual inspection of fluid;
- b) macro- and microscopic inspection of the test materials;
- c) volume change for materials;
- d) hardness change (Shore A or D) for materials;
- e) pH-measurement.

C.2.2.9.2 Procedure

The procedure is based upon ASTM D471 without tensile testing.

- a) The test specimens are weighed in air and in water and the Shore A or D hardness is measured.
- b) At 60 °C (158 °F), three replicate samples are exposed in the fluid. A separate vessel is used for each material. The same samples are by re-exposure used for the exposure periods of 1 wk, 1 mo and 3 mo, respectively. Volume change and change in hardness are measured for each sample after each testing period. At the termination of the test, the test specimens are also investigated with respect to change in appearance and formation of cracks. The fluid samples are investigated with respect to changes in appearance and the pH-value is measured.
- c) At the maximum temperature plus 10 °C (18 °F), the procedure and exposure times are the same as in b) above.

C.2.2.9.3 Results

The following results shall be noted:

- a) change in appearance of the fluid relative to unused fluid;
- b) appearance and amount of solid deposits (particles, sludge) in the fluid;
- c) pH-value of the fluid at the end of exposure;
- d) change in appearance (macro- and micro level) of polymer materials as a function of time;
- e) volume change (volume swell) of polymer materials as a function of time;
- f) change in hardness of polymer materials as a function of time.

C.2.2.9.4 Acceptance criteria

The acceptance criteria are as follows.

- a) No visible effect of the tested polymers on the appearance of the fluid.
- b) The appearance of the polymer materials shall not change during the test (some staining by the fluid is permitted for materials which tend to discolour).
- c) Volume change shall not exceed the range – 5 % to + 10 % at either temperature.
- d) Hardness change shall not exceed ± 10 % at either temperature.
- e) The development in volume and hardness change with time shall show a clear tendency to stabilization.

C.2.2.10 Thermoplastic compatibility

The pressure cycling test for thermoplastics in accordance with ISO 13628-5 is used.

NOTE For the purposes of this provision, API Spec 17E^[10] is the equivalent of ISO 13628-5.

The test material is Nylon 11 TLO⁸⁾. Samples are exposed in the fluid for 3 months and 1 year according to the ISO 13628-5 test procedure.

C.2.2.11 Filterability

C.2.2.11.1 Methods and measurements

300 ml (18,3 in³) of control fluid is filtered under specified conditions through a 0,8 µm filter membrane at a controlled pressure drop of 0,05 MPa (7,25 psi). Filterability is calculated from the ratio of filtration near the start of filtration to the filtration rate at specified higher filtered volumes.

C.2.2.11.2 Procedure

Reference is made to ISO 13357-2^[43]. The test results should be reported based on "Stage II" only. The test membranes specified in the standard might not be compatible with water/glycol-based control fluids, in which case suitable membranes have to be located. The specified filtration rating (0,8 µm) shall apply.

C.2.2.11.3 Results

The result is the ratio between the flow rate at the start of filtration and the flow rate between 200 ml and 300 ml of filtered volume, and expressed as a percentage.

C.2.2.11.4 Acceptance criteria

The required stage II filterability is 80 % or above.

C.2.2.12 Fluid lubricity and wear

C.2.2.12.1 Methods and measurements

One or both of the following tests are applied:

- a) Shell 4 ball test (see ASTM D4172)^[13];
- b) Falex testing (see modified ASTM D3233).

C.2.2.12.2 Procedure

- a) Shell 4 ball test. The details of the test procedure are given in the ASTM D4172. The test is twofold:
 - 1) The Weld point test gives an indication of load carrying capability. The steel ball is loaded and rotated against three fixed steel balls for 10 s. A rotation speed of 1 460 r/min is used. At the end of each 10 s run, a further weight is loaded onto the balls, and the test re-run using fresh fluid. The test stops when the balls weld together. The weld point is the load at which this occurs.
 - 2) The 1 h wear test gives an indication of the prevention of metal wear. The load and speed of rotation is fixed to 294 N and 1 460 r/min at the start of the test. Fresh fluid is added and the test run for 1 h. After the test, the scars on the three fixed balls are measured and an average taken. This is the mean wear scar diameter.

8) Nylon 11 TLO is an example of a suitable product available commercially. This information is given for the convenience of users of this part of ISO 13628 and does not constitute an endorsement by ISO of this product.

- b) Falex lubricant testing. The details are given in ASTM D3233, modified according to MacDermid Canning Ltd⁹⁾.

There are many different methods of evaluating the anti-wear properties of a lubricant. Most of these methods evaluate performance within a specific regime of lubrication. The lubrication regime in which a fluid operates is dependent upon a number of factors including load, speed, viscosity and the geometry of the bearing surfaces.

The natures of the chemical additives added to improve lubricity also have a significant effect on how a lubricant performs in a particular regime.

The method used to determine the performance of a lubricant should operate in the same regime as that to which the lubricant is to be used. MacDermid Plc have found that the most appropriate test method for evaluating the performance of low-viscosity hydraulic fluids is to use the Falex lubricant test.

C.2.3 Falex lubricant test

The Falex lubricant tester (see Figure C.1) is a well established method for evaluating the lubricating performance of fluids. It is generally used specifically for metal-to-metal lubricating situations.

The test load is gradually increased in 445 N (100 lbf) increments, each increment being held for a 1 min period. The torque registered at each load is noted.

The Falex test consists of a pin that is rotated at 290 r/min. On both sides of this pin is a "V"-block that exerts a load on the pin, which can be varied using lever arms on a pivot point which give an 11:1 mechanical advantage. Thus the force at the pin is 11 times greater than that given by the gripping arms.

The "V" blocks and pins are immersed in the fluid and the lubrication can be measured by the ratio of the load by the blocks on the pin and the torque required to keep the pin rotating. The wear is measured by the amount the arms need to be adjusted during the test to maintain force.

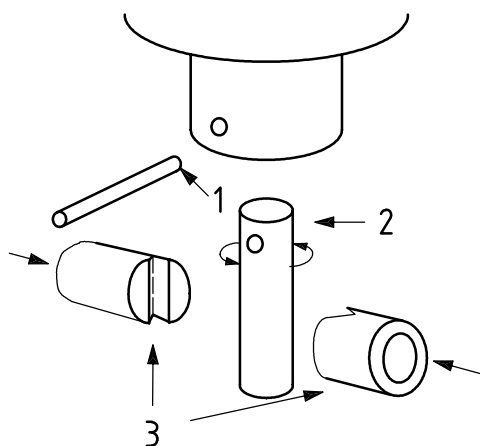

Key

- 1 brass locking pin
- 2 journal that revolves at 290 r/min
- 3 "V"-blocks

Figure C.1 — Schematic of Falex tester

9) MacDermid Canning Ltd.
Cale Lane, New Springs
WN2 1JR Wigan
UK

This reference is given for the convenience of users of this part of ISO 13628 and does not constitute an endorsement by ISO of this product.

EN ISO 13628-6:2006

The test procedure is as follows.

- a) Remove a pin and "V"-block set from the packaging.
- b) Clean the test pieces with a lint free cloth or paper and acetone.
- c) Place the pin and the "V"-blocks in the machine, securing the pin with the brass locking pin.
- d) Fit the 0 to 800 load wheel and gauge to the arms.
- e) Fill the oil cup with the fluid to be tested to the level mark in the cup.
- f) Place the oil cup under the test pieces ensuring the "V"-blocks are completely submerged.
- g) Start the pin revolving and set the load to 445 N (100 lbf) (direct load). Allow the torque to settle and record the torque produced.
- h) If the load drops by more than 22 N (5 lbf) before 1 min is complete the ratchet should be re-applied and record the number of cog teeth (known as wear teeth) to maintain the correct load. At the end of the minute the number of wear teeth required to raise the load back to 445 N (100 lbf) should be recorded.
- i) Leave at 445 N (100 lbf) for 1 min in total before increasing the load to 890 N (200 lbf) using the ratchet arm.
- j) Then leave the load at 890 N (200 lbf) for 1 min. Again record the steady torque and repeat steps g) to i) until a load of 1 334 N (300 lbf) is reached.
- k) Leave the load at 1 334 N (300 lbf) for 30 min. If the load drops before the 30 min is complete the ratchet should be re-applied and record the number of cog teeth (wear teeth) to maintain the correct load.
- l) If there is a large difference between the start and end load during the 1 min test both the start and end load should be recorded, average torque should be used to prepare the graph.

The results should be tabulated as shown in Table C.1 and a line graph of load versus torque should be produced. This graph should include the torque at 1 334 N (300 lbf) for 1 min and 30 min.

Table C.1 — Tabulation chart for Falex lubricant test

Direct load N (lbf)	Torque start N·m (lbf·in)	Torque end N·m (lbf·in)	Wear teeth
445 (100)			
890 (200)			
1 334 (300) for 1 min			
1 334 (300) for 30 min			

Standard Falex specimens with the following characteristics are used:

- journal (Falex part number 000-503-017) 1 per test run;
- outside diameter 6 mm (0,25 in);
- length 32 mm (1,25 in);
- material steel ANSI 3135;

- hardness 89 HRC \pm 2 HRC;
- surface finish 0,2 μ m RMS \pm 0,06 μ RMS (7,5 micro-inches RMS \pm 2,5 micro-inches RMS);
- “V”-block (Falex part number 000-502-100) 2 per test run;
- “V” angle 96 degrees;
- material steel ANSI C1137;
- hardness 22 HRC \pm 2 HRC;
- surface finish 0,2 μ m RMS \pm 0,06 μ RMS (7,5 micro-inches RMS \pm 2,5 micro-inches RMS).

A new journal and “V” block set is used for each test and two tests are run on each sample to ensure accuracy. Test pieces are prepared and cleaned, and the apparatus is operated and maintained, in general in accordance with the requirements of ASTM D3233, ASTM D2625 and ASTM D2670.

Some specifics with regard to solvents used for cleaning, etc. shall be varied to take account of the fact that water-base fluids are frequently evaluated. The test methods are based on the aforementioned standards, but have been modified to suit the application.

The acceptance criteria are as follows.

a) Shell 4 ball test:

- 1) Weld point test: > 1 176 N (264 lbf) minimum,
- 2) 1 h wear test: A limit of < 1,2 mm (0,047 in) for the mean wear scar diameter;

b) Falex test: 40 wear teeth for the whole test and no more than 2,8 Nm (25 lb·in) torque at 1 334 N (300 lbf) load.

If the Falex test is used to assess changes in lubricity due to ageing of a fluid by high temperature testing, no more than a 10 % change is permitted.

C.2.4 Procedure for testing of metal compatibility

C.2.4.1 General

The metal compatibility test is designed for qualification of a control fluid with respect to its compatibility towards specific metallic materials. The compatibility comprises the corrosivity of the fluid as well as the tendency of the fluid to degrade and/or form deposits in contact with the metals. It is emphasised that the test is not a materials qualification test.

Test conditions, methods and measurements, test procedure, achieved results and assessment of these as well as acceptance criteria, are described in general terms in C.2.2.8. The present document is a detailed description of a recommended procedure for the metal compatibility test.

Relevant standards are ASTM G1 and ASTM D1141.

C.2.4.2 Test materials and sample design

Table C.2 gives an overview of the materials to be tested at the three different test temperatures. The materials are tested either as plain samples or in the presence of an artificial crevice (not both). Additionally, one particular galvanic couple is included.

Table C.2 also gives the recommended size (dimensions) of the various samples. The length/width relationship may be adjusted to the shape of the test vessel. The recommended design of the samples is as follows.

a) For AISI 316 and carbon steel

Sheet samples, 40 mm × 50 mm (1,575 in × 1,968 in) with a thickness of ~ 1 mm (0,039 in). The total exposed area (edges disregarded) is 40 cm² (6,2 in²). Holes with a diameter of ~ 3 mm (0,118 in) are drilled close to the four corners of the sample ~ 5 mm (0,197 in) from the top and side edges. Two of the holes are used for fixing (suspending) the sample in the test vessel.

b) For Al-bronze, tungsten carbide with 10 % Ni binder and 17-4 PH

Cylindrical samples, 10 mm (0,394 in) in diameter and 10 mm (0,394 in) long. A ~ 2 mm (0,079 in) hole is drilled through (from end to end) for fixing the samples in the test vessel.

c) For BeCu

Disk-shaped samples with a diameter of 30 mm (1,181 in) and thickness of 5 mm (0,197 in). A ~ 2 mm (0,079 in) hole is provided to fix the samples in the test vessel.

d) Galvanic couplings are achieved by combining a bolt and nut of the less noble material (carbon steel) with a sheet sample as under (a) of the more noble material (AISI 316). A bolt and the corresponding nut with an effective diameter of 10 mm (0,394 in) (not necessarily circular) are fixed through a hole at the centre of the sheet sample. The diameter of the hole is adjusted to the diameter of the threaded part of the bolt. To ensure proper electrical contact between the two materials, the bolt/nut are fastened firmly by a suitable tool.

e) For AISI 316

Crevices are achieved in a manner similar to the galvanic coupling above. The crevices are provided by Teflon washers [~ 10 mm (0,394 in) in diameter and 1 mm (0,039 in) thick] in direct contact with the AISI 316 sheet samples (both sides) and kept in place by a through going bolt and nut made of 316 steel. For the 17-4 PH, the crevice is achieved by threading a Viton O-ring¹⁰⁾ with a suitable diameter onto the cylindrical sample.

10) Viton O-ring is an example of a suitable product available commercially. This information is given for the convenience of users of this part of ISO 13628 and does not constitute an endorsement by ISO of this product.

Table C.2 — Overview of test materials and sample size

Material specifications	Test temperature			Sample size ^a mm (in)	Crevice	Comments
	20 (68)	60 (140)	Max.			
Carbon steel EN 10025 ^[42] Grade S235	x	x	—	1 × 50 × 40 sheet (0,039 × 1,969 × 1,575)	—	—
Al-bronze SAE 701D	x	x	—	10 × 10 cylinder (0,394 × 0,394)	—	—
Tungsten carbide with 10% Ni binder	x	x	—	10 × 10 cylinder (0,394 × 0,394)	—	—
Beryllium Copper UNSC17200	x	x	—	5 × 30 disk (0,197 × 1,181)	—	—
AISI 316 ^b	x	x	x	1 × 50 × 40 sheet (0,039 × 1,969 × 1,575)	x	all samples with crevice
17-4 PH ^b	x	x	x	10 × 10 cylinder (0,394 × 0,394)	x	all samples with crevice
Carbon steel EN 10025 ^[42] Grade S235 bolt on AISI 316	x	x	—	Carbon steel bolt + nut Ø10 mm (0,394 in); AISI 316 as above	—	galvanic couple
^a Sample size is thickness × width × length.						
^b AISI 316 and 17-4 PH are only tested with crevices, not as plain samples.						

C.2.4.3 Preparation of samples

It is assumed that corresponding samples employed by the various fluid suppliers are provided by the same supplier to ensure identical surface condition and edge preparation of the samples. It is assumed that the samples come ready for use without any need for further surface preparations (grinding, polishing), preparations related to the conditions of edges or drilling of fixing holes. The samples have to be marked individually, however, for instance by engraving an identification figure.

For general aspects of sample preparations, reference is made to ASTM G1.

Prior to weighing and subsequent mounting or assembly, the samples are degreased by a 10 min immersion in acetone followed by a quick dipping in 96 % ethanol and drying (either overnight or forced by heating [maximum 70 °C (158 °F)]). All handling of the samples shall be done wearing gloves.

After drying, the samples are weighed to the nearest 0,1 mg. An accuracy of ± 0,5 mg is sufficient. The members of the galvanic couples are weighed individually before assembly. The crevice forming bolts are not weighed. Finally, the threads for suspending the samples in the testing vessels are fixed to the samples, which are now ready for exposure.

C.2.4.4 Test conditions and test set-up

The tests are carried out in the neat fluid as well as in the fluid mixed with 10 % by volume artificial seawater according to ASTM D1141; see Clause 5 of this part of ISO 13628-6.

The tests are carried out at 20 °C (68 °F) and 60 °C (140 °F) and at the maximum operational temperature plus 10 °C (18 °F). Heating is achieved by the use of heating cabinets or a water or oil bath. The specified temperatures should be maintained within ± 2 °C (± 3,6 °F).

The tests are run with three replicate samples for each test period (3 wk, 6 wk and 12 wk for the low and medium temperatures; 2 mo, 6 mo and 12 mo for high temperature). Accordingly, there are nine replicate samples for each test temperature and each metal (or metal sample variant).

Test vessels made of a material which resists the test conditions (temperature and the fluid itself) should be used. Glass is not recommended; AISI 316 or similar materials are considered to be suitable, including at the maximum test temperature. For the test at elevated temperatures, it is recommended to use test vessels lined with Teflon to avoid possible interactions between the vessel material and the fluid. This is, however, not mandatory.

The specimens are mounted in the test vessel by suspending these from the lid of the vessel or from a secondary lid or frame inside the vessel. A nylon thread which resists the conditions within the vessel (temperature as well as the fluid itself) is applied for suspending the samples. The detailed construction has to be worked out by the users of the procedure.

a) Tests at 20 °C (68 °F) and 60 °C (140 °F)

These tests are run in vessels that are large enough to house all the nine single samples (for the three testing periods). A suitable size is (width × height) 12 cm × 10 cm (4,724 in × 3,937 in), with a volume of 1 l, approximately. Smaller vessels may be used for the small (cylindrical) samples. The vessel is filled 2/3 with the fluid. The vessel is equipped with a lid (cover) which is tight enough to hinder significant evaporation of constituents (mainly water) from the fluid but which is not airtight.

The samples are suspended from the fixing holes at the top corners of the sample. There should be minimum 1,5 cm (0,591 in) space from the bottom of the vessel to the lower edge of the samples and the top level of the fluid should be minimum 1,5 cm (0,591 in) above the top edge of the samples.

The fluid is used without any de-aeration or gas purging.

After 3 wk and 6 wk respectively, three replicate samples are removed from the vessel while the remaining samples are exposed further for the required testing period.

b) Test at maximum temperature

This test is run in vessels which are airtight and designed to withstand the pressure corresponding to the vapour pressure at the appropriate temperature. Accordingly, these are pressure vessels that should not be opened before the end of the test period. Hence, there shall be one vessel for each testing period of 2 mo, 6 mo and 12 mo for each of the two test materials. For the two materials and three testing periods, six vessels are then required.

A suitable volume of the vessel is 1 l (61 in³) with dimensions as above. Again, by filling the vessel 2/3 of the total, the fluid volume is approximately 0,7 l (42,7 in³). However, a smaller vessel may be used if required.

The placement of the vessels (all temperatures) shall ensure that the specimens are fully immersed. The vessels as described here shall, therefore, stand upright and should not be tilted.

C.2.4.5 Monitoring and termination of the tests

During exposure of the samples, no monitoring of the tests is required with the exception of regular checks regarding signs of leakage from the vessels. In the case of an evident leakage from a vessel, the test in that particular vessel should be stopped and started over again.

For the tests at 20 °C (68 °F) and 60 °C (140 °F), samples are removed from the vessels after 3 wk and 6 wk, respectively. This operation should be as quick as possible and the vessel should be covered with a spare lid while the samples are being dismantled from the lid of the vessel.

At the termination of the tests, the vessels heated at 60 °C (140 °F) and at the maximum temperature are cooled to an appropriate temperature with respect to ease of handling before they are opened. After opening

the vessels, the samples are dismantled from the lid. Care should be taken not to lose any fluid during this operation.

The specimens as well as the fluid are now ready for further inspections and assessment.

C.2.4.6 Inspection and evaluation of metal samples and solution after test

C.2.4.6.1 Inspection of metal specimens

Immediately after the specimens have been recovered from a test vessel, regardless of testing period, they are visually inspected (by naked eye) and for each specimen a qualitative description of the appearance including type of corrosion and amount, distribution and appearance of corrosion products, is written down. The specimens with crevices and the galvanic couples are then dismantled. If there are any further observations related to the crevices or the area of galvanic contact, these are recorded. All handling should be carried out wearing gloves.

As soon as the above characterization has been carried out all the samples are washed under running water while loose corrosion products are removed by using a soft brush. Immediately after washing a single sample, it is dipped into 96 % ethanol and dried by tissue paper.

The next step is to chemically clean the specimen in the appropriate chemical cleaners. This is done in accordance with ASTM G1. Table C.3 relates the specific test materials in the present procedure to the corresponding material in ASTM G1:2003, Table A.1. The cleaning is completed by washing under running water, dipping in ethanol, drying by tissue paper and air drying overnight or in an oven.

After the preparation of a new stock solution of each of the chemical cleaners, the mass loss of a new (unexposed) sample of the corresponding metal should be checked to make sure the solution (by a mixing fault) has not become too corrosive towards the metal to be cleaned. The mass loss should be negligible.

Table C.3 — Recommended procedures for chemical cleaning of the specimens

Material specifications	Cleaning procedure ^a
Carbon steel EN 10025 ^[42] Grade S235	As for iron and steel
Al-bronze SAE 701D	As for copper and copper alloys
Tungsten carbide with 10 % Ni binder	No procedure specified. Use washing/brushing in water only.
Beryllium copper UNSC17200	As for copper and copper alloys
AISI 316	As for stainless steels
17-4 PH	As for stainless steels
^a Related to ASTM G1:2003, Table A.1.1	

The specimens, including all the parts of the galvanic couples, are then weighed and the mass loss is calculated. The mass loss is translated into a corrosion rate, expressed as micrometres per year, by the conversion formulas given in Table C.4.

The specimens are then investigated visually both by naked eye and under a microscope. In addition to a qualitative description of the condition of the specimens with respect to corrosion attacks, any significant local attacks (such as pitting or crevice corrosion) should be characterized quantitatively as far as possible. In particular, the maximum depth of the local attacks should be measured. This is done by selecting a certain number of attacks (say 5) that appear to be the largest or deepest and measure the depth of these. Suitable techniques are using a stylus on a calibrated wheel or (better) a microscope with a calibrated depth of focus. The deepest attack found is recorded as the maximum depth of local attacks to be compared with the acceptance criterion.

Any attacks that are clearly related to the edges of the specimens, fixture holes or engravings are disregarded.

Table C.4 — Transformation of corrosion mass loss into corrosion rate in micrometres per year

Material specifications	Density ^a g/cm ³	Material dependent constant K_M
Carbon steel EN 10025 [42] Grade S235	8	$1,5 \times 10^4$
Al-bronze SAE 701D	8,5	$1,4 \times 10^4$
Tungsten carbide with 10 % Ni binder	15	$0,8 \times 10^4$
Beryllium Copper UNSC17200	9	$1,3 \times 10^4$
AISI 316	8	$1,5 \times 10^4$
17-4 PH	8	$1,5 \times 10^4$

^a Approximate values.

The formula for the corrosion rate, R , expressed in micrometres per year, is given by Equation (C.1):

$$R = \frac{\Delta w}{A \times T \times \rho} \tag{C.1}$$

$$R = 12 \times 10^4 \left(\frac{w}{A \times T \times \rho} \right) = \left[\frac{12 \times 10^4}{\rho} \right] \left[\frac{w}{A \times T} \right] = K_M \left(\frac{w}{A \times T} \right)$$

where

- w is the measured mass loss, in grams;
- A is the total area of specimen, in square centimetres;
- T is the exposure time, in months;
- ρ is the density (approximate) of metal or alloy, in grams per cubic centimetre;
- K_M is a constant, which depends on the material, and is equal to 12×10^4 divided by the density of the material.

C.2.4.6.2 Inspection of the fluids

As soon as possible after the test has been terminated and at least the same day, the fluid is transferred from the test vessel to a clean glass beaker with a cover. Any solid matter at the walls or bottom of the test vessel is transferred together with the fluid. If necessary, it is scraped off the walls by a suitable tool.

The volume of the fluid is measured and any loss of fluid is calculated. There are no strict limits in the main procedure as to permissible fluid loss. It should not exceed 5 % of the total, however.

The pH-value of the fluid is measured and a qualitative description of the appearance of the fluid is written down. This applies to colour and colour changes compared with unused fluid, any signs of a secondary liquid phase at the top or bottom of the fluid, solid precipitates, sludge or other segregations.

The fluid is then left for 24 h in the glass beaker after which any further changes in appearance including settlement of deposits are recorded. Thereafter, the fluid is filtered as specified. The fluid is again left on the bench for 24 h after which a final inspection is carried out and any further changes recorded.

C.2.4.7 Assessment of results and reporting

The procedure as described above provides results related to the corrosion performance of the various metallic materials in the fluid at the test conditions as a function of time. These results should, however, be interpreted as a documentation of the corrosivity of the fluid but not as materials performance.

The results, furthermore, provide information on the stability of the fluid in contact with the various metallic materials at the test conditions. This is interpreted from changes in fluid appearance, changes in pH-value and formation of deposits or other separations other than obvious corrosion products. To fully interpret the results, a comparison with the results from the stability tests in the absence of metals should be carried out.

A summary of the assessment of the results is given as follows:

- a) corrosivity of the fluid:
 - general qualitative description of the corrosion performance of each metal and the galvanic couples, including appearance, extent, nature (corrosion form) and distribution of corrosion attacks and corrosion products,
 - for the metals tested with crevices, the tendency towards crevice corrosion,
 - for the galvanic couples, the tendency towards galvanic corrosion of the less noble metal in the couple,
 - mass loss of each metal tested as a function of time,
 - stipulated average corrosion rate, expressed in micrometres per year, at the end of the total test period [3 mo for 20 °C (68 °F) and 60 °C (140 °F); 6 mo and 1 year for maximum temperature],
 - maximum depth of local attacks as a function of time,
 - qualitative assessment of the corrosivity of the fluid (mass loss and local attacks) as a function of time;
- b) fluid stability:
 - pH-value of the fluid and any changes relative to the initial value. From this and the corresponding measurements in fluids in the absence of metals, it may be concluded how the various metals affect the pH-value. There is no acceptance criterion related to the results.
 - changes in colour of the fluid in the presence of the various metals. There is no acceptance criterion related to the results.
 - qualitative description of deposits or other segregations formed in the fluid. The acceptance criteria related to this aspect are that there should be no substantial amount of either corrosion products or other deposits (particles, sludge) at the end of the test period.

C.2.4.8 Step-by-step procedure

C.2.4.8.1 Preparation of samples

Wear gloves while handling samples.

There are three replicate samples for each test condition and each test period. For each material, samples for the three testing periods are exposed in the same vessel for the tests at 20 °C (68 °F) and 60 °C (140 °F).

- a) Mark the specimens by engraving or other means.
- b) Degrease 10 min in acetone.
- c) Flush by running water.

- d) Dip quickly into 96 % ethanol.
- e) Pat dry by tissue paper.
- f) Leave under dust-free conditions overnight or dry in an oven [maximum 70 °C (158 °F)].
- g) Weigh individual samples and the individual members of the galvanic couples to the nearest 0,1 mg.
- h) Assemble galvanic couples and samples with crevices.
- i) Fix suspension threads to samples and fix to the (inner) cover of the vessels. It shall be ensured that the samples are not closer than 1,5 cm (0,59 in) to the bottom of the test vessel and not less than 1,5 cm (0,59 in) from the top level of the fluid. Samples should be arranged in such a manner that they do not touch each other or the walls of the vessel after being immersed in the fluid.

Sample bundles are now ready for exposure.

C.2.4.8.2 Preparation of solutions

- a) Filter the required volume of fluid as specified in the main procedure.
- b) Prepare the solution with 10 % by volume artificial seawater according to ASTM D1141 without heavy metals.
- c) Measure the pH-value of the neat fluid and of the seawater mixture.
- d) Measure out the required volume of the fluid (neat and mixture with seawater) for each vessel and pour it into the appropriate test vessel. Accuracy in volume reading should be ± 5 ml ($\pm 0,3$ in³).

C.2.4.8.3 Start and continuation of test

- a) Arrange the bundle of samples in the vessel. Placement shall be according to C.2.4.8.1 i). The vessels should stand upright.
- b) Close or seal vessel in accordance with the requirements for the actual test temperature.
- c) Heat the vessel to the appropriate temperature.
- d) Carry out regular inspections as to any signs of leakage from the vessels. In case of evident leakage (or a visible volume drop) stop the test in that vessel and start over again.

C.2.4.8.4 Intermittent removal of samples at for 20 °C (68 °F) and 60 °C (140 °F) after 3 wk and 6 wk

- a) Remove the vessels from the controlled temperature environment.
- b) Let the vessels at 60 °C (140 °F) cool to a suitable handling temperature limited to 1 h cooling time.
- c) Open the vessel and remove the cover with the bundle of samples. Unnecessary loss of liquid should be avoided during this operation.
- d) Replace the cover with a spare cover.
- e) Take the appropriate three replicate samples from the bundle, remove spare cover and arrange remaining samples and cover on the vessel again.
- f) Transfer the vessel back to the controlled temperature environment.
- g) Proceed with the next vessel.

The specimens from the intermittent exposures (3 wk and 6 wk) at for 20 °C (68 °F) and 60 °C (140 °F) are now ready for cleaning and assessment.

C.2.4.8.5 Termination of tests

This is valid for the vessels that are not exposed further [12 wk at for 20 °C (68 °F) and 60 °C (140 °F)] and all exposure times for the maximum temperature test).

- a) Remove the vessels from the controlled temperature environment.
- b) Let the heated vessels cool to a suitable handling temperature limited to 4 h cooling time.
- c) Open the vessel and remove the cover with the bundle of samples. Unnecessary loss of liquid should be avoided during this operation.
- d) Place the bundle of samples on the bench. Proceed to C.2.4.8.7.
- e) If the test is not carried out in a glass vessel, transfer the solution and as much as possible of any solids that have precipitated in the fluid to a glass beaker. Proceed to C.2.4.8.6.

C.2.4.8.6 Inspection and assessment of fluid after test

- a) Measure the volume of the fluid with an accuracy of ± 5 ml (0,3 in³).
- b) Measure the pH-value of the fluid.
- c) Make a qualitative description of the appearance of the fluid and relate the appearance to the new fluid. Colour, segregations, particles, sludge etc. should be described.
- d) Cover the beaker and leave the fluid for 24 h. Repeat C.2.4.8.6 b).
- e) Run the fluid through a filter as specified and leave it for further 24 h. Repeat b) as a final inspection and characterization.
- f) After drying in air, the content of the filter is investigated and described. No weighing is required.
- g) Relate the results to the relevant acceptance criteria.
- h) Photographs should be used as far as possible for documentation.

C.2.4.8.7 Inspection and assessment of metal samples after test

All handling of the samples should be done wearing gloves. This procedure applies to all samples including the ones recollected after 3 wk and 6 wk at for 20 °C (68 °F) and 60 °C (140 °F).

- a) Inspect the specimens by naked eye as soon as they have been taken from the test vessel. For galvanic couples and samples with crevice, this is done before dismounting. Characterize the appearance of the samples, including appearance and distribution (where on the sample) of corrosion products and attacks, amount of corrosion products (qualitatively as, for instance, minor, slight, moderate, substantial, major, etc.). For the samples with crevice and the galvanic couples, one should note whether the attacks are more extensive close to the bolts employed.
- b) Dismantle each sample from the bundle, flush it under running water and use a soft brush to help remove loose corrosion products. For the samples with crevice and the galvanic couples, this is done for each metallic part after dismantling.
- c) Pat dry each sample with tissue paper and immediately transfer it into the appropriate chemical cleaner in accordance with ASTM G1; see also Table C.3 in this part of ISO 13628.

- d) After chemical cleaning, flush the samples with running water, dip quickly in 96 % ethanol, pat dry by tissue paper and air dry overnight or dry by heating.
- e) Weigh the samples including the individual members of the galvanic couples, calculate mass loss and convert figures into micrometres per year according to Table C.4.
- f) Investigate the samples by naked eye and under a microscope at a suitable magnification. Characterize the corrosion attacks by describing form(s) of corrosion, qualitative extent and distribution of corrosion and indicate qualitatively number, size and location of local attacks.
- g) Disregard attacks which are clearly related to the edges of the samples or to fixing holes or engravings.
- h) If there are any local attacks (pitting or crevice corrosion) select the five attacks which appear to be largest or deepest. Measure the maximum depth of these by a suitable instrument. Accuracy should be at least $\pm 5 \mu\text{m}$.
- i) Select the attack with maximum measured depth to be related to the relevant acceptance criterion.
- j) For the galvanic couples, evaluate how the galvanic contact has affected the corrosion performance and to what extent the less noble metal (carbon steel) was susceptible to galvanic corrosion.
- k) For samples with a crevice, evaluate how the crevice has affected the corrosion performance and to what extent the metal tested (AISI 316 or 17-4 PH) was susceptible to crevice corrosion.
- l) Consider the development of the various corrosion attacks with time and establish (for instance by a mass loss — time diagram) whether the corrosion rates show a decreasing, stable or increasing trend with time.
- m) Relate the results to the relevant acceptance criteria.
- n) Photographs should be used as far as possible for documentation.

C.3 Property requirements of synthetic control fluids

C.3.1 Test specifications

It is a general requirement that all test fluid shall be pre-filtered before the testing starts, either in a dynamic test rig where the minimum accumulated filtered volume is 7 times the reservoir volume of the rig, or by a single pass through a Millipore membrane (or similar). Filtration ratio of the dynamic test rig filter shall be equal to or greater than 200 at $3 \mu\text{m}$. The single-pass Millipore type filter shall have a filtration rating of $1,2 \mu\text{m}$.

C.3.2 General

Fluid property requirements for -synthetic based fluids are described in C.3.3 to C.3.11.

Qualification tests shall be performed by the fluid manufacturer in order to qualify a fluid formulation under this part of ISO 13628. The fluid being tested shall meet or exceed all acceptance criteria in order to qualify.

C.3.3 Appearance

The fluid shall be a clear, transparent, mobile liquid free from suspended material.

C.3.4 Water content

The water content shall be determined by the Karl-Fischer method.

C.3.5 Pour point

The pour point shall be determined in accordance with ASTM D97, in which the acceptance criterion is a minimum pour point of $-10\text{ }^{\circ}\text{C}$ ($14\text{ }^{\circ}\text{F}$).

C.3.6 Flash point

The flash point shall be determined in accordance with IP 34. The acceptance criterion is a minimum flash point of $140\text{ }^{\circ}\text{C}$ ($284\text{ }^{\circ}\text{F}$).

C.3.7 Corrosion test

The anti-corrosion performance shall be determined in accordance with ASTM D665:2003, Clauses 9 and 10. Both tests shall be carried out in duplicate for a period of 24 h at $60\text{ }^{\circ}\text{C}$ ($140\text{ }^{\circ}\text{F}$) using a standard carbon steel test pin. The acceptance criterion is no rust.

C.3.8 Anti-wear test

C.3.8.1 General

The two standard procedures for the assessment of anti-wear performance of water- and oil-based fluid products are the ASTM D2596^[12] (Shell 4 ball test) and a modified version of the Falex lubricant test.

C.3.8.2 ASTM D2596

The ASTM D2596^[12] method evaluates the anti-welding characteristics of a lubricant. Performance is evaluated by assessing the load before welding of the test pieces occurs, the load at which initial seizure occurs and the wear occurring under a constant low load. The minimum characteristics are outlined in Table C.5.

Table C.5 — Minimum anti-welding characteristics

Characteristic	Oil-based fluid
Weld point:	Minimum 1,26 kN (283 lbf)
Initial seizure load:	Minimum 0,49 kN (110 lbf)
Mean scar diameter	Maximum 0,60 mm (0,024 in)

C.3.8.3 Falex test

The modified Falex test as defined in C.2.2.12 b) evaluates the lubricity of the fluid. The acceptance criteria under Method A are 1,33 kN (300 lbf) load and torque less than 2,26 Nm (20 in-lbf). The acceptance criteria under Method B are less than 15 % change in torque characteristics (from Method A) and a weight loss on the pin of less than 0,2 mN (1,8 in-lbf).

C.3.9 Elastomer compatibility

Elastomer compatibility shall be determined in accordance with ASTM D471, in which the acceptance criteria and elastomer type are determined by the purchaser.

Representative compatibility should be assessed in accordance with ASTM D471 using the standard elastomer grades listed below. This is intended to give an indication of a fluid's effect on typical commonly used types of elastomer. A minimum immersion period and temperature is considered to be 168 h at $70\text{ }^{\circ}\text{C}$

(158 °F). However, extended test periods (typically 2 000 h) are recommended to identify the stabilization point.

Typical elastomers include nitrile-butyl rubber (high nitrile), nitrile-butyl rubber (medium nitrile) and fluorocarbon.

C.3.10 Thermoplastics compatibility

Compatibility with thermoplastics materials to be used in umbilicals or as flexible connections in the form of jumper hoses between the umbilical termination and the end user shall be determined by the procedure outlined in ISO 13628-5.

Note For the purposes of this provision, API Spec 17E^[10] is the equivalent of ISO 13628-5.

The test method and acceptance criteria for compatibility testing with thermoplastics materials for uses other than in control umbilicals should be determined by the purchaser.

C.3.11 Fluid stability

Given that the lifetime of most projects is between 10 years and 20 years, the long-term stability of the fluid is extremely important. Data on the fluid shall be generated, but the scope, method and acceptance criteria shall be agreed by the purchaser.

As a minimum, an ageing period of 2 000 h at temperatures of – 10 °C (14 °F), 0 °C (32 °F), and 70 °C (158 °F) along with a period at a temperature 10 °C (50 °F) above the maximum operating temperature of the fluid is required. Pressure-test vessels made of corrosion-resistant material should be used for the elevated temperature testing.

Changes in viscosity at 40 °C (104 °F) and deposits per litre of fluid should be reported.

The mechanical stability of the fluid shall be evaluated at the operational temperature(s) and at the lower and upper ends of the specified temperature range. The evaluation shall demonstrate that under static conditions, over time and under pressure, the fluid remains 100 % homogeneous and does not form a multiphase system. The effect of seawater ingress on the fluid stability shall also be addressed as part of the evaluation.

C.3.12 Environmental effects

C.3.12.1 General

The use of organometallic compounds should be avoided. Testing should be performed according to current Oslo and Paris Commission (OSPAR) Guidelines^[47].

Acceptance criteria should be in accordance with local legislation.

C.3.12.2 User information requirements

Table C.6 gives a list of fluid properties to be supplied to users by the manufacturer. Properties shall be ascertained by the manufacturers using the following test methods.

Table C.6 — Fluid properties to be listed by manufacturer

Property	Method
Density	ASTM D1298
Kinematic viscosity at 0 °C (32 °F), 40 °C (104 °F) and 100 °C (212 °F)	ASTM D445
Bulk modulus	ISO 6073 (all parts)
Foaming characteristics	ASTM D892
Cleanliness count	ISO 4406 ^a
^a For the purposes of this provision, AS 4059 ^[51] is the equivalent of ISO 4406.	

C.4 Test methods

C.4.1 Modified Falex lubricant test

Two methods of evaluation are used, both involving a standard Falex lubricant tester. The test pieces used are steel pins and V-blocks, totally immersed in the fluid.

Method A is carried out by increasing the contact load between the V-blocks and rotating pins in increments of 0,45 kN (100 lbf) to a maximum load of 1,33 kN (300 lbf). Each load increment is maintained for a period of 60 s. A reading is taken of the resultant torque (proportional to the frictional force) and the number of ratchet teeth required to maintain the load (proportional to the linear wear taking place) at each 0,45 kN (100 lbf) increment. The resultant data are presented as graphs of torque vs. applied load and number of wear teeth vs. applied load.

Method B is carried out immediately after method A, using the same test pieces, and is run at a continuous load of 1,33 kN (300 lbf) for a period of 30 min. Once again, torque and wear are recorded during the test period, and the resultant data are in this case presented as graphs of torque vs. time and number of wear teeth vs. time.

C.4.2 Test method — Falex lubricant tester

C.4.2.1 Method A: 0 kN to 1,33 kN (0 lbf to 300 lbf) load

- a) Insert new pin and V-block. Fill bath with new test fluid. Start machine with no load applied and allow to run for 60 s.
- b) Apply load via the ratchet mechanism until 0,45 kN (100 lbf) level is reached. Allow to run for 60 s.
- c) Increase load via the ratchet mechanism. If the load has dropped below the 0,45 kN (100 lbf) level during the 60 s run, record the number of ratchet teeth required to re-establish the 0,45 kN (100 lbf) level of load. Record the torque reading at 0,45 kN (100 lbf) load.
- d) Continue loading via the ratchet mechanism until the 0,90 kN (200 lbf) load level is reached. Allow to run for 60 s.
- e) Repeat steps c) and d) for loads up to 1,33 kN (300 lbf) in 0,45 kN (100 lbf) increments. At each increment, record the number of ratchet teeth required to re-establish test load at the end of the 60 s run (if load has dropped) and the torque, prior to proceeding to the next test load, until data for loads up to and including 1,33 kN (300 lbf) load have been obtained.

C.4.2.2 Method B: 30 min at 1,33 kN (300 lbf) load

- a) After completing the 1,33 kN (300 lbf) test period (60 s) and recording the number of ratchet teeth to re-establish the 1,33 kN (300 lbf) load (and the torque), increase the load to 1,38 kN (310 lbf).
- b) Allow the test to continue for 30 min from this point. Should the test load drop to 1,29 kN (290 lbf), use the ratchet mechanism to re-establish the 1,38 kN (310 lbf) load level, record the number of ratchet teeth required, and note the torque on re-establishing the 1,38 kN (310 lbf) test load. Record the time at which the load dropped to 1,29 kN (290 lbf).
- c) At the end of the test period, remove the load completely prior to switching off the Falex machine.
- d) Retain the pin and V-block for examination.

C.4.3 High-temperature fluid testing requirements

C.4.3.1 General

This evaluation shall be performed as a minimum whenever the control system operating fluid is intended for service above 90 °C (194 °F). The test temperature shall be 10 °C (50 °F) above the maximum predicted operating temperature.

The tests are designed to record changes in the fluid in the following areas:

- sludge/deposits;

NOTE These can lead to blockages and increased wear.

- acidity, reported as TAN and TBN;
- viscosity.

Viscosity is a sign of product degradation and shall therefore be recorded. The percent mass change of the fluid before/after test shall be quoted next to any viscosity data.

C.4.3.2 Test vessel

The test vessel should have

- 316 stainless steel wetted components;
- a full-opening top to permit "straight through" cleaning and inspection;
- a capacity of 500 ml (16,9 in³).

C.4.3.3 Test procedure (three vessels required)

All fluids used for flushing and cleaning in this procedure shall be filtered through a nominal 0,8 µm pore size filter.

- a) Clean the three test vessels with filtered petroleum spirit. Let the vessels dry in a clean lint-free environment. (Do not use an air line to dry the vessels, as this will introduce contamination.) Test for vessel cleanliness by filling with 150 ml (5,1 in³) petroleum spirit for oil-based fluid tests, agitate, then count particles. The acceptance criterion is less than 500 particles of diameter greater than 5 µm per 100 ml (3,5 in³) of fluid.
- b) Fill vessels with 400 ml ± 5 ml (13,4 in³ ± 0,3 in³) of the control fluid.

- c) Purge the air space above the control fluid with dry filtered nitrogen and regulate the pressure to a value sufficient to prevent boiling of the control fluid. Maintain this pressure throughout the test. Heat the vessels to the desired temperature and maintain $\pm 1\%$ throughout the test.
- d) Remove one vessel after each of
- 1) 330 h;
 - 2) 670 h;
 - 3) 2 000 h.

The vessels and fluid shall be weighed before and after test, and any mass loss recorded.

C.4.3.4 Qualification tests

Values for the virgin fluid shall be obtained from the manufacturer or determined in addition to the three aged samples. The virgin sample should have the same batch number as the fluid tested.

a) Appearance evaluation

Pour the contents of the vessel into a clean, clear cylinder of 500 ml (30,5 in³) capacity. Do not remove or disturb sediments and deposits. Fluid colour and condition (clear/hazy/opaque) shall be recorded.

b) Acidity evaluation

Use 15 ml (0,92 in³) to 30 ml (1,83 in³) for the TAN and TBN tests.

c) Deposit and sludge evaluation

Flush sediments from the vessel with filtered fluid. Deposits on the walls shall be scraped and flushed. The mass of the solids shall be determined to within $\pm 1\%$. If any particles were found in the previous tests they should be included here. Report the particle size distribution and characteristics, and the amount of deposits based on Table C.7.

Table C.7 — Deposits

Fluid classification	Deposits	
	mg/l	lb/in ³
A	0 to 10	0 to $0,361 \times 10^{-6}$
B	10 to 100	$0,361 \times 10^{-6}$ to $3,61 \times 10^{-6}$
C	100 to 1 000	$3,61 \times 10^{-6}$ to $36,1 \times 10^{-6}$
D	greater than 1 000	greater than $36,1 \times 10^{-6}$

d) Corrosion evaluation

Test the fluid in accordance with IP 135:2005, section A, (10 % distilled water dilution).

C.4.3.5 Acceptance criteria

No absolute acceptance criteria have been determined. The original properties of the fluid along with the changes undergone shall be used to evaluate the suitability of the fluid. These tests allow a comparison of fluids and a means for the operator and fluid manufacturer to evaluate the long-term effects of high temperature on the fluid.

Annex D (informative)

Operational considerations with respect to flowline pressure exposure

D.1 General

A subsea production system can be classified as follows:

- subsea production system rated to maximum shut-in pressure;
- subsea production system with pressure restrictions;
- subsea production system with pressure protection.

Functional requirements for the subsea production control system should be based on the classification of the subsea production system.

D.2 Subsea production system rated to maximum shut-in pressure

Subsea production systems, including flowlines and risers that are rated to maximum shut-in pressure, should be the preferred base case. Hence, in this case, the topside systems are designed to handle maximum shut-in pressure. Operational challenges in this case are shutdown situations and pressure relief situations.

In this case topside safety is maintained by the riser system and riser system valves.

The following elements are applicable for such a system.

- Shutdown of subsea production systems can be minimized since topside safety is maintained by riser system valves.
- Exposure of differential pressure across subsea valves and chokes can be controlled and minimized.
- Down-time of production control system can be accepted without immediate subsea shutdown since personnel safety is controlled by the topside system.

An operational philosophy which allows the subsea valves to be in an open status regardless of the topside status shall be considered. Cooling of subsea wells can be significantly reduced in a shutdown situation if wells are allowed to “produce” into flowlines and/or other wells. Wear of subsea valves can be reduced if pressure build-up in flowlines is allowed thus reducing differential pressures across subsea trees.

D.3 Subsea production system with flowlines that have limitations with respect to exposure to maximum shut-in pressure

Several occasions can result in pressure restrictions being set on flowlines even though the flowline itself is rated to maximum shut-in pressure. These occasions can be related to pressure ratings of topside manifold, pressure rating of swivel, limitations in topside pressure relief system, etc.

A field which is based on pressure restrictions being put on flowlines, requires optimization between subsea and topside design. This operational philosophy puts operational limitations on the subsea production system. In addition, enhanced functional requirements with respect to control and shutdown of the subsea system are required, compared to the preferred system described in D.2.

An immediate shutdown of the subsea system is required whenever the topside system is shutdown. The number of subsea shutdown situations increases compared to the preferred case. Subsea valves/chokes are exposed to differential pressure. The criticality of chokes is increased compared to the preferred case system since differential pressure has to be maintained.

Shutdown of subsea wells results in rapid well cooling, thus enhancing the requirements for actions to prevent hydrate formation. Operability of a methanol injection system has to be emphasized. Control system impact shall be considered.

The subsea system is shutdown when high pressure in flowlines is detected.

Consequences of communication errors between topside and subsea are decided.

This operational scenario requires a certain response time of shutdown system. Response time criteria shall be developed as part of front-end engineering.

Control system availability is important in these cases. Location of topside control equipment can have a significant impact on total system availability. Location in a permanent safe area is preferred.

Control co-ordination between topside and subsea chokes is required to prevent unacceptable pressures occurring in flowlines. Functional design specifications shall be developed during front-end engineering.

D.4 Subsea production system including high integrity pipeline protection system (HIPPS)

In this scenario, the flowlines are not rated to well shut-in pressure. Hence, a HIPPS functionality is implemented.

The HIPPS shall be autonomous.

The HIPPS shall activate upon detection of high pressure in flowlines. HIPPS maximum response time requirement shall be established.

The control and shutdown philosophy shall be as follows.

- The production control system shall act as first barrier to prevent pressure build-ups in flowlines. This shall be done through a robust control strategy, including topside and subsea control. Both feedback and forward control algorithms shall be evaluated (control level).
- The second barrier to prevent pressure build-ups in flowlines shall be the subsea PSD system using topside and subsea pressure transmitters (process shutdown level).
- The third barrier to prevent pressure build-up in flowlines shall be the HIPPS system. In this context the HIPPS system represents the ESD functionality (ESD level).

Subsea control system availability is of utmost importance for the system operability in these types of applications.

Critical safety unavailability and test interval criteria shall be established and documented for ESD and PSD systems for this type of application.

The design of the HIPPS system should be based on the methods and guidelines provided in IEC 61511^[39] and IEC 61508 (all parts)^[40].

Annex E (normative)

Interface to intelligent well

E.1 Physical interfaces

E.1.1 Option 1 — Subsea electronic module (SEM) interface

E.1.1.1 General

A single IWCS interface installed inside the SEM of the subsea control module shall be one of the following (see ANSI 1014:1987, Section 7^[2]):

- a single Eurocard;
- two single Eurocards;
- a single Eurocard occupying two consecutive slots.

Each connector shall be a Euro Connector in accordance with DIN 41612-2 (see Table E.1, for detailed specifications and pin connector allocation).

Temperature ratings shall be in compliance with 5.4.2.3 and 5.4.2.4.

Fault tolerance shall be provided to ensure that the integrity of the SEM electronics is maintained in the event of any failure on the interface card(s).

Diagnostics shall be provided. As a minimum, this shall include the ability to “ping” the interface card in order to prove the communications interface.

E.1.1.2 Eurocard ANSI 1014:1987, Section 7 — Deviations

None.

E.1.1.3 Intelligent well interface card — Euro connector DIN 41612-2

Table E.1 — Euro connector DIN 41612-2

DH-INTERFACE Pin-outs, DIN 41612-2 Full 96-pin male connector on DH-interface			
Pin no.	DESCRIPTION		
	Row A	Row B	Row C
1	ETH TX+	ETH RX+	Reserved DH
2	ETH TX-	ETH RX-	Reserved DH
3	Reserved DH	Reserved DH	Reserved DH
4	Chassis GND	Chassis GND	Chassis GND
5	Chassis GND	Chassis GND	Chassis GND
6	Chassis GND	Chassis GND	Chassis GND
7	+ Power in	+ Power in	+ Power in
8	+ Power in	+ Power in	+ Power in
9	+ Power in	+ Power in	+ Power in
10	– Power in	– Power in	– Power in
11	– Power in	– Power in	– Power in
12	– Power in	– Power in	– Power in
13	Ch A TxD +	Ch A isolated GND	Ch A RxD +
14	Ch A TxD –	Ch A isolated GND	Ch A RxD –
15	Ch B TxD +	Ch B isolated GND	Ch B RxD +
16	Ch B TxD –	Ch B isolated GND	Ch B RxD –
17	Reserved DH	Reserved DH	Reserved DH
18	Reserved DH	Reserved DH	Reserved DH
19	Reserved SS	Reserved SS	Reserved SS
20	Reserved SS	Reserved SS	Reserved SS
21	–Reserved SS	Reserved SS	–Reserved SS
22	Not connected	Not connected	Not connected
23	–DH armor	DH armor	–DH armor
24	–DH armor	DH armor	–DH armor
25	Not connected	Not connected	Not connected
26	DH Pwr – OUT-	DH Pwr OUT-	DH Pwr – OUT-
27	–Not connected	Not connected	–Not connected
28	DH Pwr OUT+	DH Pwr OUT+	DH Pwr OUT+
29	–Not connected	Not connected	–Not connected
30	–EXT power RET	EXT power RET	–EXT power RET
31	Not connected	Not connected	Not connected
32	–EXT power+	EXT power+	–EXT power+

E.1.2 Option 2 — Subsea control module (SCM) interface

The IWCS electronics including the power supply are installed within a separate pressure enclosure, which may be mounted either internally or externally to the SCM. This enclosure shall comply with 7.4.5. This enclosure is termed iSEM.

The space allocated for the iSEM shall host a cylinder of 260 mm (10,236 in) diameter by 510 mm (20,078 in) length (maximum outside dimensions). Clearance for the electrical/optical interconnection shall not exceed 150 mm (5,906 in) on the end of the cylinder.

The following features shall be incorporated in the enclosure design:

- designed to accommodate any mounting orientation;
- corrosion-resistant against seawater and common dielectric fluids;
- protected against water intrusion. The design should include two separate and testable barriers (see 7.4.5);
- the enclosure shall be designed for full external pressure conditions, see 7.4.5.

The electrical (see E.2) and/or optical interface shall be designed using a penetration or connector suitable for the design pressure and being resistant against seawater and common dielectric fluids.

All interconnecting cables and connectors shall be suitable for direct exposure to the subsea environment. If the iSEM is mounted outside the dielectric fluid filled SCM, all interconnecting cables and connectors shall provide a double barrier against seawater-induced malfunctions.

The material necessary to electrically/optically connect to the iSEM either shall be commercially available or shall be provided by the iSEM vendor. This material shall interface to individual leads.

E.1.3 Option 3 — External interface

The IWCS components shall be contained within an enclosure to provide environmental protection and allow retrieval with a ROT or ROV.

Electronics shall be contained within a pressure enclosure, which shall comply with 7.4.5.

The actual point of interface may be at the SCM or at some other subsea interface. If the interface is at the SCM, the subsea production control system supplier shall provide low or medium electrical power as specified in 8.5.5.

If a direct connection is made to an umbilical power supply, then detailed system power analysis and failure mode analysis shall be carried out to ensure that system integrity is maintained.

E.2 Electrical interface

This subclause describes the electric signals that shall be passed to the iSEM. The interface shall provide protection against short circuit between signals, short circuit between signal and ground and electrostatic discharge.

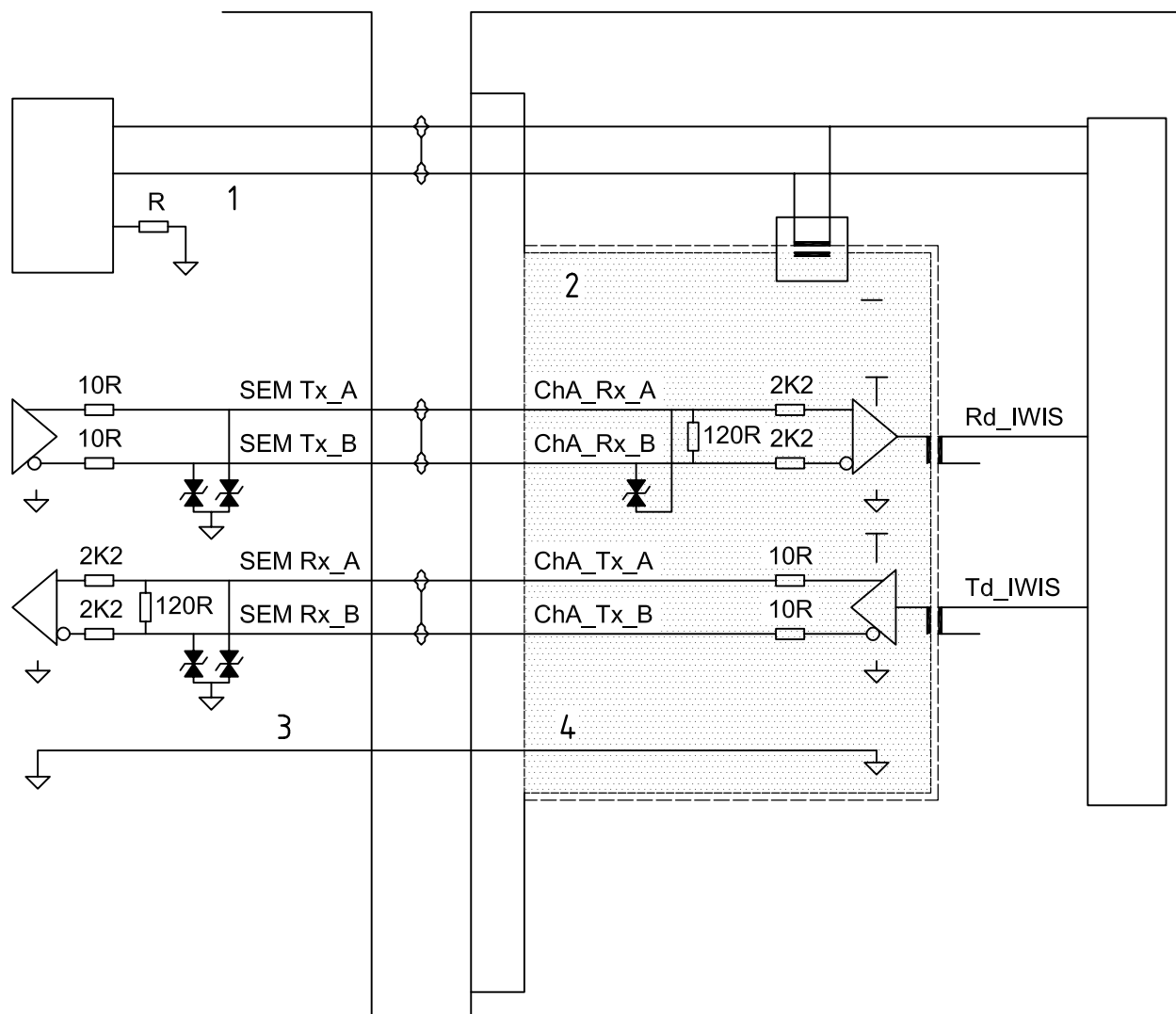

Key

- 1 power
- 2 isolation
- 3 signal ground
- 4 isolated G

Figure E.1 — Typical communication port interface

If redundancy is required, dual power and dual communication signals shall be provided.

For each wire, the following parameters shall be defined:

- a) wire size;
- b) twisting;
- c) shielding/grounding.

For downhole connections, the following parameters shall be defined:

- operating voltages and currents;

- grounding and shielding;
- number and type of connections;
- communication carrier frequency and modulation type.

E.3 Surface integration

E.3.1 Guideline to the interface with regard to the operation of the system

The function of the host facility is to enable normal operation as well as expert operation of the intelligent well equipment.

Expert operation of the IWE, such as using diagnostic data (see Figure E.2 and Table E.2), may be performed by IWCS (only).

Data transfer to the DCS/MCS shall use OPC. Data should be transferred in the relevant engineering unit form.

E.3.2 Example system data flow diagrams

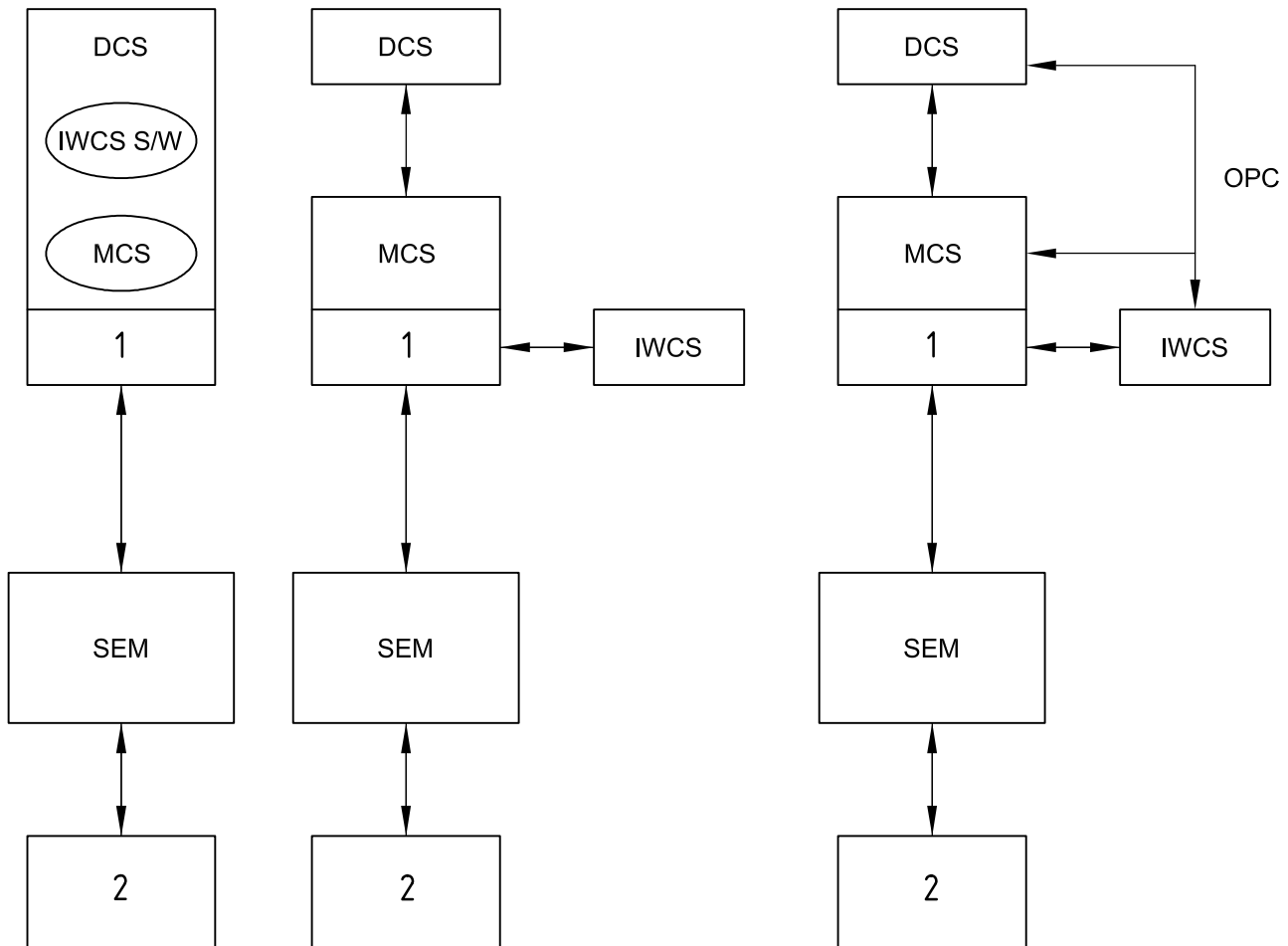

Key
 1 subsea gateway
 2 iSEM or interface card

Figure E.2 — Example systems flow diagram

E.4 Electrical power interface

Table E.2 — Electrical power interface

Power requirements	Low power	Medium power
Power supply	24 W	500 W
Voltage operational window	20 VDC to 28 VDC	140 VAC to 265 VAC
Input frequency	N/A	47 Hz to 63 Hz
Power factor	N/A	> 0,95 (on/off selectable)
Voltage ripple	1 % up to 1 MHz	N/A
EMC	TBD	TBD
Input power transient	120 % of max. input for 10 ms	120 % of max. input for 10 ms
Cold start inrush power	120 % of max. input for 500 ms	120 % of max. input for 500 ms
Heat dissipation	Max. 6 W (from interface card)	Max. 100 W (within dedicated SEM)

E.5 Testing

E.5.1 Qualification testing

Qualification testing shall be conducted, at a minimum as described in 11.2.5.

E.5.2 Environmental stress screening (ESS)

ESS shall be conducted, at a minimum, as described in 11.3.5.

Annex F (informative)

Definition of subsea electromagnetic environment and guidance on the selection of tests, limits and severity to provide a presumption of compliance of subsea equipment

F.1 General

As no other standard or guide considers equipment deployed on the seabed, some examples of subsea environments are defined here and classified by location class using the principles of IEC/TS 61000-2-5^[29].

Test techniques, severity levels and limits are derived from IEC 60945^[26], IEC 60533^[22], IEC 61000-3-4^[31] and IEC 61000-4-6^[34].

In determining the selection of tests and their limits or severity levels, the test plan should take cognizance of the fact that while the deployed environment is subsea, the test and commissioning locations are likely to be the generic industrial environment, the above-decks ship environment, or both.

F.2 Description of environment

The environment described in this part of ISO 13628 is that of the seabed. When electrical and electronic equipment is deployed on the seabed, a local EM environment is established. As higher-power equipment and more complex production control systems are deployed, the EM environment becomes harsher. No matter what equipment is deployed, one common factor in these environments is the connection to the host facility, the umbilical cable. At the host end of the umbilical in both onshore and offshore installations, the environment is at least generic industrial with possibly a high density of co-located electrical and electronic equipment. Each field installation has umbilicals of differing make-up, length and configuration. The umbilical characteristics influence the contribution made to the subsea environment by the surface environment. Field stepout and daisy-chained umbilicals influence the environment of each node of the configuration.

This environment is not well-documented but has been the subject of several research papers in recent years. This part of ISO 13628 does not attempt to describe the natural physical properties but selects the most obvious characteristics that affect the EM phenomena associated with equipment deployed in this environment. The seabed medium is composed of the interface between seawater, sediment and/or bedrock. The different layers of this medium have different characteristics but in particular the conductivity varies between 1 S/m and 5 S/m for the seawater, between 0,1 S/m and 0,5 S/m for the sediment and below 0,05 S/m for bedrock. In general, this environment does not propagate radiated high-frequency electromagnetic fields nor can there be any electrostatic charge. However, the diffusive and attenuation effects of these conductive mediums mean that propagation of electromagnetic waves at frequencies in the low end of the EM spectrum cannot be ruled out.

F.3 Conducted low-frequency phenomena

F.3.1 Supply frequency harmonics

This phenomenon is caused by the power converters, generators and monitoring equipment used on the surface to supply electrical power to the subsea system. There is also a contribution from any subsea high-power drives that are powered from the same sources. This contribution can be significant in complex field configurations deploying multiple examples of the same equipment types.

F.3.2 Supply voltage and frequency variations

Subsea production systems are designed to operate with large input-voltage ranges to accommodate supply characteristics that vary according to the equipment location relative to the field configuration. Long umbilical distances between equipment give rise to significant differences in supply characteristics. For this reason, power analysis is undertaken for each field installation, taking into account such effects as load variations, umbilical characteristics and fault conditions. As this phenomenon is fully considered in the operating environment, it is not included in the EM environment.

F.3.3 Induced voltages

This is generally, but not entirely, a common mode phenomenon caused by the coupling of power harmonics and inter-harmonics to signal and control cables. The type of coupling is a function of the configuration of the cables, interconnections and their relationship to other parts of the production facility. Circuit and stray impedances determine the mode of coupling. The EM compatibility is influenced by the type, quantity and relative location of equipment.

F.3.4 Radiated low-frequency phenomena

F.3.4.1 Radiated magnetic fields

Power cables, transformers and high power process plant equipment generate this phenomenon. It is manifest by coupling of power fundamental and harmonic frequencies onto signal and control lines.

F.3.4.2 Radiated electric fields

All cables, particularly high voltage power cables, generate this phenomenon. The subsea environment is very poor at propagating high-frequency electric fields and so the higher frequency range can be ignored for the deployed environment.

F.3.5 Conducted high-frequency phenomena

F.3.5.1 Signalling voltages — Combined power and signal

Some production-control systems use combined power and signal on supply cables (mains signalling). As the supply to the production facility is a dedicated power network, this differential signalling can be at higher power levels and at different frequencies from those used in public distribution networks. The power and frequency of the communications signal are dependent on the modem, which in turn can be field-specific.

F.3.5.2 Induced continuous wave voltages and currents

The close proximity of cables and equipment mounted on common metallic structures can induce interference signals by electromagnetic coupling within equipment or via common ground coupling. This phenomenon can propagate through the interface to remote equipment of the same system.

If several equipment types generate common-mode ground signals, the conducted continuous wave phenomena can be complex and harsh. The degree of coupling is a function of circuit and stray impedances, cable lengths and their proximity to common ground structures.

The subsea facility can form part of the circuit of induced currents caused by electromagnetic fields present in the surface environment.

By the nature of the deployment of subsea production equipment, there is potentially an array of jumper cables that can be in the medium that is formed at the interface between the seawater and seabed. These cables can be carrying power and/or signal, be of considerable length and any number of them can be the conducting path for common mode currents. It is possible that because of the length of cables, resonance can occur at low frequencies. Taking into account the conductivity of the medium in which these cables are

located, there can be low-frequency EM waves propagated within the medium from these cables, particularly when the cables are resonant. The same cables can be receptors of these EM waves, with coupling dependent on the length of each cable, the interface design, their separation and the frequency of the wave.

F.3.5.3 Transients

Oscillatory and very fast surges can occur due to load switching around the local production facility or at other production facilities being part of the same field installation. They can also be generated in surface equipment, particularly in the power supply system for the installation and be transmitted down the umbilical.

High energy or slow surges are generally caused by distant lightning strikes on host facilities or release of stored energy in fault conditions.

The characteristics of resultant surge phenomena, from the surface environment, appearing at subsea facilities are defined by the characteristics of the umbilical and equipment termination.

F.3.6 Radiated high-frequency phenomena

The subsea environment does not propagate high frequency electromagnetic fields and so these phenomena can be ignored for the deployed environment.

F.3.7 Electrostatic discharge phenomena

As the normal operating location is subsea these phenomena can be ignored for the deployed environment.

F.4 Disturbance degrees

F.4.1 General

It is not possible to definitively determine the compatibility levels for each of the phenomena considered to be part of the subsea environment because *in situ* tests cannot be performed and there is little published data on which to base suggestions. Therefore, the guidance given here has been developed from the nearest equivalent surface environments. The disturbance degrees suggested for the phenomena listed in F.4.2 to F.4.4 are based on those specified in the IEC 61000 series guides and include a statistical approach to the likelihood of the presence of the phenomena. For safety-related systems and systems with functional safety criteria, consideration should be given in the test plan to developing worst-case predictions to satisfy the safety integrity requirements of the project.

The effect of the umbilical is complex in that field configuration, length, cable gauge, skin effect, screens, armouring, insulation materials and termination all contribute to the characteristics.

F.4.2 Conducted low-frequency phenomena

F.4.2.1 Harmonics

With reference to IEC/TS 61000-2-5:1995^[29], Table 2, locations with high power equipment, such as frequency-controlled motors, or feeds to such equipment, could experience a THD factor of 10 %. Other locations with only electronic modules are unlikely to exceed 8 %. The disturbance degrees suggested in the location tables (see Table F.5 to Table F.8) are those of IEC/TS 61000-2-5:1995^[29], Table 2.

F.4.2.2 Supply voltage and frequency variations

No disturbance degrees offered, installation-specific.

F.4.2.3 Induced voltages

The disturbance level is influenced by the local distribution of equipment and hence field topography dictates the actual disturbance degree. The influence of the umbilical from the host facility on the disturbance level is case-specific and is ignored.

The disturbance degrees suggested in the location tables are those of IEC/TS 61000-2-5:1995^[29], Table 5.

F.4.3 Radiated low-frequency phenomena

F.4.3.1 Radiated magnetic fields

The disturbance degrees suggested in the location tables are those of IEC/TS 61000-2-5:1995^[29], Table 6.

F.4.3.2 Radiated electric fields

The disturbance degrees suggested in the location tables are those of IEC/TS 61000-2-5:1995^[29], Table 7.

F.4.4 Conducted high-frequency phenomena

F.4.4.1 Signalling voltages

Combined power and signal systems produce a signalling voltage on the power supply lines dependent on the modem power, frequency and system configuration. This voltage represents a threat to equipment that does not form part of the communications system but is part of the power system. Harmonics of the signal frequency, disturbance from adjacent systems and differential power supply harmonics all contribute to a threat to the communications system from out-of-band disturbances and a reduction of signal-to-noise ratio due to in-band disturbances.

With existing technology, the modem power outputs are typically on the order of 20 dBm to 35 dBm, with nominal circuit impedances of 100 ohm. The voltage appearing on the umbilical terminals can be from 5 volts rms to 15 volts rms with normal operating frequencies from 100 Hz to 150 kHz. Actual values depend on the modem configuration, system termination and umbilical characteristics.

Any equipment operating from a combined power and signal supply but not required to be part of the signalling network, is or can be expected to be supplied with a de-coupling filter to maintain correct umbilical termination for the communications signal. This filter is or can be expected to provide a minimum of 20 dB attenuation to the signalling frequencies; see Table F.1.

Table F.1 — Disturbance degrees for signalling voltages in combined power and communications systems

Disturbance degrees	In-band frequency range ^a volt rms
A – network without signalling	Case-by-case according to equipment requirements
1 Emission level, near to the transmitter \leq 24 dBm power	5
2 Emission level, near to the transmitter \leq 30 dBm power	10
3 Emission level, near to the transmitter \leq 33 dBm power	15
Others	Case-by-case dependent on modem power and system configuration
^a Definition of “in-band frequency range” is case-specific and defined by the manufacturer.	

F.4.4.2 Induced CW voltages and currents

Using IEC/TS 61000-2-5:1995^[29], Table 8, as a reference, the following Table F.2 has been derived. The values of degree have been adjusted from IEC/TS 61000-2-5:1995^[29], Table 8, by applying an attenuation factor due to the effect of the conductivity of the seabed medium normalized at 0,01 MHz (the lowest frequency of IEC/TC2 61000-2-5:1995^[29], Table 8, and at 1 m (3,28 ft) distance. Due to the geometry of potential cable emitters, the coupling degree is difficult to predict and, as such, any consideration of propagation velocity and of far-field and near-field effects are ignored.

Table F.2 — Disturbance degrees of induced CW voltages with respect to reference ground

Disturbance degree	0,01 to 0,05 MHz		0,5 to 4 MHz		4 to 13,5 MHz		13,5 to 27 MHz		27 to 80 MHz	
	V	mA	V	mA	V	mA	V	mA	V	mA
A (controlled)	Case-by-case according to equipment requirements									
1	1	7	0,3	2	0,1	0,7	-	-	-	-
2	1	7	1	7	0,3	2	0,1	0,7	-	-
3	3	21	3	21	1	7	0,3	2		
X	Case-by-case according to the situation									

There are no published data available on which to base a range of disturbance degrees for the subsea location, however the relationship between the field strength and the induced voltage is nominally linear for cable lengths greater than a sixth of the wavelength. Resonance effects occur when the dimensions of the loop approach a quarter wavelength and multiples thereof. Table F.2 gives values of induced voltages and corresponding values of common mode currents calculated by assuming a characteristic impedance with respect to ground reference of 150 ohms. It should be noted that actual characteristic impedance subsea is likely to be lower due to the seabed medium. However, 150 ohms is used here to maintain consistency with existing standards.

The degrees in Table F.2 are for unmodulated conditions. Normally occurring disturbance signals are amplitude modulated (typically less than 80 % modulation) or frequency modulated.

F.4.4.3 Transients

The “contact arcing” transient disturbance degrees of IEC/TS 61000-2-5:1995^[29], Table 9, are those shown against HF-conducted unidirectional transients in the location tables and the “high frequency” oscillatory transient disturbance degrees of Table 10 are those shown against HF-conducted oscillatory transients in the location tables. All are assumed to be locally derived. Locally generated slow transients of the form in IEC/TS 61000-2-5:1995^[29], Table 9, under “fuse operation” are possible and the disturbance degrees of Table 9 are used in the location tables.

Any distant lightning surge is directly affected by the field topography, and the umbilical in particular, and is case-specific, and therefore is not included in the location tables.

F.5 Permissible emissions

For all the locations the permissible emissions are those that do not approach the disturbance degrees described in F.4, and thus do not contribute significantly to the electromagnetic environment. Emissions of all ports should be kept to below the limits imposed by CISPR for industrial environments for frequencies above 150 kHz.

For emissions below 150 kHz, Tables F.3 and F.4 apply.

Table F.3 — Limits for conducted disturbance at the mains ports

Frequency range MHz	Limits dB(μ V) ^a	
	Quasi-peak	Average
0,003 to 0,15	111,5 to 79	98,5 to 66
^a The limits decrease linearly with the logarithm of the frequency in the range 0,003 MHz to 0,15 MHz.		

Special consideration should be given for equipment designed to be part of, or work with, a combined power and signal system. CISPR requirements define a line impedance stabilization network with which the emission measurements are to be made, standard measurement equipment could attenuate the communications frequencies to the extent of total loss. Mitigation measures will need to be employed in order to make CISPR measurements. At communication frequencies, open-limit exclusion bands need to be applied to the frequency range in Table F.1 for CPS communications equipment, these are case-specific and defined by the manufacturer. For non-communications equipment, lower limits need to be applied for the same frequency band, again being case-specific depending on required signal-to-noise specifications of the CPS system and defined by the manufacturer.

Table F.4 — Limits of conducted common mode (asymmetric mode) disturbance at input /output ports in the frequency range 0,003 MHz to 0,15 MHz

Frequency range MHz	Limits dB(μ V) ^{a,b}		Limits dB(μ A) ^{a,b}	
	Quasi-peak	Average	Quasi-peak	Average
0,003 to 0,15	129,5 to 97	116,5 to 84	85,5 to 53	72,5 to 40
^a The limits decrease linearly with the logarithm of the frequency in the range 0,003 MHz to 0,15 MHz.				
^b The current and voltage disturbance limits are derived for use with an impedance stabilizing network which presents a common mode (asymmetric mode) impedance of 150 ohms to the I/O port under test (conversion factor is $20 \log_{10} 150/1 = 44$ dB).				

IEC 61000-3-2^[30] applies below 3 kHz for equipment drawing up to 16 A per phase. IEC 61000-3-4^[31] applies for higher power equipment.

F.6 Performance criteria

Performance criteria to be applied during immunity testing:

- Performance criterion class A.** There shall be no loss of function, loss of stored data or change of state. In particular, this means that there shall be no uncommanded action that violates the functional safety requirements. No degradation of performance beyond the specified tolerances should be allowed. In particular, communications performance should not be degraded beyond the specified tolerances and should not promote any automated action to maintain the communications function.
- Performance criterion class B.** There should be no loss of stored data or change of state. In particular, this means that there should be no uncommanded action that violates the functional safety requirements. Degradation of performance should be limited to the temporary loss of the communications function and temporary degradation of performance beyond the specified tolerances, which is restored without user intervention afterwards.
- Performance criterion class C.** There should be no loss of stored data. In particular there should be no uncommanded action that violates the functional safety requirements. A commanded reset should restore all functions.

F.7 Subsea location class and descriptions

F.7.1 Subsea location — Class type 1

Following are the attributes of environment and associated ports:

a) enclosure:

- no broadcast transmitters,
- no HV lines,
- close proximity to high-power ISM,
- high concentration of ITE,
- close proximity to MV power-switching,
- proximity of MV cables;

b) ac power:

- CPS,
- RPC,
- cables for medium-power plants,
- possibility of dedicated feeders,
- resident power factor correction
- large variable-speed drive systems,
- high-inrush loads,
- possibility of high fault currents;

c) dc power:

- CPS,
- RPC,
- switched inductive loads,
- high-inrush loads;

d) signal/control:

- far-reaching lines,
- multi-cable subsea jumpers likely,
- close coupling between signal systems and switched power systems;

- e) earth:
- interface with extensive networks,
 - extensive ground mats, generally well-controlled,
 - interconnected separate ground mats,
 - large ground loops,
 - possibility of large ground fault currents.

NOTE Class 1 is typical of a subsea multiple process control manifold that can contain high power drives and numerous control and instrument systems. It is probably located a considerable distance from the host facility, consequently the effect imposed on this environment by the host umbilical is considered to be insignificant. None of the other subsea equipment connected by umbilical increases the disturbance degree.

Table F.5 — Subsea location class type 1

Phenomenon		Details	Disturbance degrees for five ports				
			Enclosure	AC power	DC power	Control and signalling	Earth
LF-conducted	Total harmonics Distortion	IEC/TS 61000-2-5: 1995 ^[29] , Table 2	b	2	b	b	b
	Signalling 0,1 kHz -150 kHz	Annex F, Table 1	b	Case-by-case	Case-by-case	b	b
	Voltage fluctuations	IEC/TS 61000-2-5: 1995 ^[29] , Table 4	b	c	c	b	b
	Voltage dips			c	c		
	Short interruptions			c	c		
	Voltage unbalance			c	c		
Frequency variations	c						
Induced LF	IEC/TS 61000-2-5: 1995 ^[29] , Table 5	b	b	b	4	3	
DC in AC networks	a	b	a	a	a	b	
LF magnetic field	DC	IEC/TS 61000-2-5: 1995 ^[29] , Table 6	2				
	Power system		b				
	Power system harmonics		2	b	b	b	b
	Not power system related		2 1				
LF electric field	DC lines	IEC/TS 61000-2-5: 1995 ^[29] , Table 7	2				
	Power system (50 Hz to 60 Hz)		b 2	b	b	b	b
HF-conducted Induced CW	10 MHz to 80 MHz	Annex F Table 2	b	3	3	3	b
HF-conducted Unidirectional Transients	Nanoseconds	IEC/TS 61000-2-5: 1995 ^[29] , Table 9	b	3	3	3	
	Microseconds, close			b	b	b	b
	Microseconds, distant			b	b	b	b
	Milliseconds		2	2	b		
HF-conducted Oscillatory Transients	High frequency	IEC/TS 61000-2-5: 1995 ^[29] , Table 10	b	3	b	2	
	Medium frequency			b	b	b	b
	Low frequency			b	b	b	b

Table F.5 (continued)

Phenomenon		Details	Disturbance degrees for five ports				
			Enclosure	AC power	DC power	Control and signalling	Earth
HF-radiated Oscillatory	9 kHz-27 MHz Any source 27 MHz band CB Amateur radio All bands 27 MHz to 1 000 MHz portable except CB 27 MHz to 1 000 MHz mobile except CB 27 MHz to 1 000 MHz all others 1-40 GHz all sources	IEC/TS 61000-2-5: 1995 ^[29] , Table 11	b	b	b	b	b
HF-radiated Pulsed	Lightning, distant power-system related	IEC/TS 61000-2-5: 1995 ^[29] , Table 12	b	b	b	b	b
Electrostatic discharge	Slow Fast	IEC/TS 61000-2-5: 1995 ^[29] , Tables 13 and 14	b	b	b	b	b
<p>^a Under consideration.</p> <p>^b Consideration should be given to the test and commissioning environment.</p> <p>^c Equipment design incorporates frequency and voltage variation tolerance to configuration specification.</p>							

F.7.2 Subsea location — Class type 2

Following are the attributes of environment and associated ports:

- a) enclosure:
 - no broadcast transmitters,
 - no HV lines,
 - close proximity to low -power ISM,
 - proximity of MV cables;
- b) ac power:
 - CPS,
 - cables for medium-power plants,
 - possibility of dedicated feeders;
- c) dc power:
 - CPS;
- d) signal/control:

- far-reaching lines,
 - multi-cable subsea jumpers likely;
- e) earth:
- extensive ground mats, generally well-controlled,
 - interconnected separate ground mats,
 - large ground loops.

NOTE 1 Class 2 can be typical of a subsea distribution manifold with minimal equipment. It can be located a short distance from the host facility, consequently the effect imposed on this environment by the host facility via the umbilical can be considerable. Any other subsea equipment connected by umbilical is considered to be located at a considerable distance and not to increase the disturbance degree.

NOTE 2 As the construction of the umbilical is determined by configuration specifications that differ enormously from case to case, any attempt at quantifying the effects on EM phenomena, particularly common mode, propagated along the umbilical is unrewarding. For this reason, the disturbance degrees in Table F.6 do not account for any phenomena conducted along the umbilical, if these are considered significant, it is necessary to use location class type 1.

Table F.6 — Subsea location class type 2

Phenomenon		Details	Disturbance degrees for five ports				
			Enclosure	AC power	DC power	Control and signalling	Earth
LF-conducted	Total harmonics distortion	IEC/TS 61000-2-5: 1995 ^[29] , Table 2	b	1	b	b	b
	Signalling 0,1 kHz to 150 kHz	Annex F, Table 1	b	Case-by-case	Case-by-case	b	b
	Voltage fluctuations Voltage dips Short interruptions Voltage unbalance Frequency variations	IEC/TS 61000-2-5: 1995 ^[29] , Table 4	b	c c c c c	c c c	b	b
	Induced LF	IEC/TS 61000-2-5: 1995 ^[29] , Table 5	b	b	b	3	2
	DC in AC networks	a	b	a	a	a	b
	LF magnetic field	DC	IEC/TS 61000-2-5: 1995 ^[29] , Table 6	1 b			
Power system		2		b	b	b	b
Power system harmonics		2					
Not power system related		1					
LF electric field	DC lines	IEC/TS 61000-2-5: 1995 ^[29] , Table 7	b				
	Power system (50 Hz to 60 Hz)		b 2	b	b	b	b
HF-conducted Induced CW	10 MHz to 80 MHz	Annex F, Table 2	b	2	2	2	b
HF-conducted Unidirectional Transients	Nanoseconds Microseconds, close Microseconds, distant Milliseconds	IEC/TS 61000-2-5: 1995 ^[29] , Table 9	b	2 b b 1	2 b b 1	2 b b -	b

Table F.6 (continued)

Phenomenon		Details	Disturbance degrees for five ports				
			Enclosure	AC power	DC power	Control and signalling	Earth
HF-conducted	High frequency	IEC/TS 61000-2-5: 1995 ^[29] , Table 10	b	2	b	2	b
Oscillatory	Medium frequency			b	b	b	
Transients	Low frequency			b	b	b	
HF-radiated	9 kHz to 27 MHz	IEC/TS 61000-2-5: 1995 ^[29] , Table 11	b	b	b	b	b
Oscillatory	Any source						
	27 MHz band CB						
	Amateur radio						
	All bands						
	27 MHz to 1 000 MHz portable except CB						
	27 MHz to 1 000 MHz mobile except CB						
	27 MHz to 1 000 MHz all others						
	1 GHZ to 40 GHZ all sources						
HF-radiated	Lightning, distant	IEC/TS 61000-2-5: 1995 ^[29] , Table 12	b	b	b	b	b
Pulsed	power-system related						
Electrostatic discharge	Slow	IEC/TS 61000-2-5: 1995 ^[29] , Tables 13 and 14	b	b	b	b	b
	Fast						
<p>^a Under consideration.</p> <p>^b Consideration should be given to the test and commissioning environment.</p> <p>^c Equipment design incorporates frequency and voltage variation tolerance to configuration specification.</p>							

F.7.3 Subsea location — Class type 3

Following are the attributes of environment and associated ports:

- a) enclosure:
 - no broadcast transmitters,
 - no HV lines,
 - high concentration of ITE,
 - close proximity to low -power ISM;
- b) ac power:
 - CPS,
 - RPC;

- c) dc power:
- CPS,
 - RPC,
 - switched inductive loads;
- d) signal/control:
- far-reaching lines,
 - multi-cable subsea jumpers likely;
- e) earth:
- extensive ground mats, generally well-controlled,
 - interconnected separate ground mats,
 - large ground loops.

NOTE 1 Class 3 can be typical of a subsea control manifold and production tree cluster supporting several integrated electronic systems. It can be located a long distance from the host facility, consequently the effect imposed on this environment by the host facility via the umbilical is likely to be minimal. Any other subsea equipment connected by umbilical is considered to be located at a considerable distance and not to increase the disturbance degree.

NOTE 2 As the construction of the umbilical is determined by configuration specifications that differ enormously from case to case, any attempt at quantifying the effects on EM phenomena, particularly common mode, propagated along the umbilical is unrewarding. For this reason the disturbance degrees in Table F.7 do not account for any phenomena conducted along the umbilical; if these are considered to be significant, it is necessary to select a higher disturbance degree.

Table F.7 — Subsea location class type 3

Phenomenon		Details	Disturbance degrees for five ports				
			Enclosure	AC power	DC power	Control and signalling	Earth
LF-conducted	Total harmonics Distortion	IEC/TS 61000-2-5: 1995 ^[29] , Table 2	b	2	b	b	b
	Signalling 0,1 kHz to 150 kHz	Annex F, Table 1	b	Case-by-case	Case-by-case	b	b
	Voltage fluctuations	IEC/TS 61000-2-5: 1995 ^[29] , Table 4	b	c	c	b	b
	Voltage dips			c	c		
	Short interruptions			c	c		
	Voltage unbalance			c	c		
	Frequency variations			c	c		
Induced LF	IEC/TS 61000-2-5: 1995 ^[29] , Table 5	b	b	b	2	1	
DC in AC networks	a	b	a	a	a	b	
LF magnetic field	DC	IEC/TS 61000-2-5: 1995 ^[29] , Table 6	b	b	b	b	b
	Power system		b				
	Power system harmonics not power system related		2				
			1				

Table F.7 (continued)

Phenomenon		Details	Disturbance degrees for five ports				
			Enclosure	AC power	DC power	Control and signalling	Earth
LF electric field	DC lines	IEC/TS 61000-2-5: 1995 ^[29] , Table 7	b				
	Power system (50 Hz to 60 Hz)		b 1	b	b	b	b
HF-conducted Induced CW	10MHz to 80 MHz	Annex F, Table 2	b	2	2	2	b
HF-conducted Unidirectional transients	Nanoseconds	IEC/TS 61000-2-5: 1995 ^[29] , Table 9		3	2	2	
	Microseconds, close		b	b	b	b	b
	Microseconds, distant			b	b	b	
	Milliseconds		1	1	b		
HF-conducted Oscillatory Transients	High frequency	IEC/TS 61000-2-5: 1995 ^[29] , Table 10		1	b	1	
	Medium frequency		b	b	b	b	b
	Low frequency			b	b	b	
HF-radiated Oscillatory	9 kHz to 27 MHz	IEC/TS 61000-2-5: 1995 ^[29] , Table 11					
	Any source						
	27 MHz band CB						
	Amateur radio						
	All bands						
27 MHz to 1 000 MHz portable except CB		b	b	b	b	b	
27 MHz to 1 000 MHz mobile except CB							
27 MHz to 1 000 MHz all others							
1 GHz to 40 GHz all sources							
HF-radiated Pulsed	Lightning, distant Power-system related	IEC/TS 61000-2-5: 1995 ^[29] , Table 12	b	b	b	b	b
Electrostatic discharge	Slow Fast	IEC/TS 61000-2-5: 1995 ^[29] , Tables 13 and 14	b	b	b	b	b
<p>^a Under consideration.</p> <p>^b Consideration should be given to the test and commissioning environment.</p> <p>^c Equipment design incorporates frequency and voltage variation tolerance to configuration specification.</p>							

F.7.4 Subsea location — Class type 4

Following are the attributes of environment and associated ports:

- a) enclosure:
 - no broadcast transmitters,
 - no HV lines;

- b) ac power:
— CPS;
- c) dc power:
— CPS;
- d) signal/control:
— lines are usually short, less than 10 m (32,8 ft);
- e) earth:
— single metallic structure well bonded.

NOTE 1 Class 4 can be typical of a subsea production tree located a considerable distance from the nearest facility, consequently the effect imposed on this environment by other facilities via the umbilical is negligible.

NOTE 2 As the construction of the umbilical is determined by configuration specifications that differ enormously from case to case, any attempt at quantifying the effects on EM phenomena, particularly common mode, propagated along the umbilical is unrewarding. For this reason, the disturbance degrees in Table F.8 do not account for any phenomena conducted along the umbilical; if these are considered to be significant, it is necessary to select a higher disturbance degree.

Table F.8 — Subsea location class type 4

Phenomenon		Details	Disturbance degrees for five ports				
			Enclosure	AC power	DC power	Control and signalling	Earth
LF-conducted	Total harmonics Distortion	IEC/TS 61000-2-5: 1995 ^[29] , Table 2	b	1	b	b	b
	Signalling 0,1 kHz to 150 kHz	Annex F, Table 1	b	Case-by-case	Case-by-case	b	b
	Voltage fluctuations	IEC/TS 61000-2-5: 1995 ^[29] , Table 4	b	c	c	b	b
	Voltage dips			c	c		
	Short interruptions			c	c		
	Voltage unbalance			c			
	Frequency variations			c			
Induced LF	IEC/TS 61000-2-5: 1995 ^[29] , Table 5	b ₋	b	b	1	b	
DC in AC networks	a	b	a	a	a	b	
LF magnetic field	DC	IEC/TS 61000-2-5: 1995 ^[29] , Table 6	b				
	Power system		b	b	b	b	
	Power system harmonics not power system related		2				
LF electric field	DC lines	IEC/TS 61000-2-5: 1995 ^[29] , Table 7	b				
	Power system (50-60 Hz)		b	b	b	b	b
				1			

Table F.8 (continued)

Phenomenon		Details	Disturbance degrees for five ports				
			Enclosure	AC power	DC power	Control and signalling	Earth
HF-conducted Induced CW	10 MHz to 80 MHz	Annex F, Table 2	b	1	1	1	b
HF-conducted Unidirectional Transients	Nanoseconds Microseconds, close Microseconds, distant Milliseconds	IEC/TS 61000-2-5: 1995 ^[29] , Table 9	b	b b b	b b- b-	b b- b	b
HF-conducted Oscillatory Transients	High frequency Medium frequency Low frequency	IEC/TS 61000-2-5: 1995 ^[29] , Table 10	b	1 b b	b b b	1 b b	b
HF-radiated Oscillatory	9 kHz to 27 MHz Any source 27 MHz band CB Amateur radio all bands 27 MHz to 1 000 MHz portable except CB 27 MHz to 1 000 MHz mobile except CB 27 MHz to 1 000 MHz all others 1 GHz to 40 GHz all sources	IEC/TS 61000-2-5: 1995 ^[29] , Table 11	b	b	b	b	b
HF-radiated Pulsed	Lightning, distant power-system related	IEC/TS 61000-2-5: 1995 ^[29] , Table 12	b	b	b	b	b
Electrostatic Discharge	Slow Fast	IEC/TS 61000-2-5: 1995 ^[29] , Table 13 and 14	b	b	b	b	b
^a Under consideration. ^b Consideration should be given to the test and commissioning environment. ^c Equipment design incorporates frequency and voltage variation tolerance to configuration specification.							

F.8 Immunity test standards levels

The severity levels suggested in Table F.9 are to enable compliance with the environment defined in the location tables. For a more benign environment or safety-related system, the immunity levels should be adjusted down and up, respectively, to suit the requirements of the project.

Table F.9 — IEC cross reference — Disturbance degrees to test standards

Phenomenon		IEC/TS 61000-2-5: 1995 ^[29]		ISO 13628-6:2006, Annex F		Test standard	
		Table	Disturbance degrees	Table	Disturbance degrees	Levels	Reference
LF- conducted	Total harmonic distortion	2	A 1 2			— 1 2	IEC 61000-4-13 ^[37] (16,5 Hz to 2 kHz) (performance criteria A)
	Signalling 0,1 kHz to 3 kHz			1	A 1 2 3 X	No choice ^a	IEC 60945:2002 ^[26] , section 10.2 (50 Hz to 10 kHz) (performance criteria A)
	3 kHz to 150 kHz				1		
	Voltage fluctuations Voltage dips Short interruptions Voltage unbalance Frequency variations	4	N/A				
	Induced LF (50 Hz to 20 kHz)		5			Not directly comparable a	IEC 61000-4-16 ^[38] (part) Excluding 400 Hz supplies (15 Hz to 150 kHz) (performance criteria A)
LF magnetic field	DC	6					No standard
	Railway		N/A				
	Power systems		A			1	IEC 61000-4-8 ^[35] (performance criteria A)
			1			2	
			2			3	
3				4			
4			5				
X			X				
Power system harmonics					No standard		
Not related to power system					No standard		
LF electric field	DC lines	7					No standard
	Railway (16 2/3 Hz)		N/A				
	Power system (50 Hz to 60 Hz)					No standard	
HF-conducted induced CW	10 kHz to 150 kHz			2	A 1 2 3 X	- 1 2 3 4 X	IEC 61000-4-16 ^[38] (15 Hz to 150 kHz) (performance criteria A)
	0,1 MHz to 30 MHz 30 MHz to 150 MHz				2	A 1 2 3 X	- 1-- ^b 2-1-- ^c 3-2-1 ^c X

Table F.9 (continued)

Phenomenon		IEC/TS 61000-2-5: 1995 ^[29]		ISO 13628-6:2006, Annex F		Test standard	
		Table	Disturbance degrees	Table	Disturbance degrees	Levels	Reference
HF-conducted unidirectional transients	Nanoseconds	9	A			-	IEC 61000-4-4 ^[32] (performance criteria B)
			1			1	
			2			2	
			3			3	
			4			4	
			X			X	
	Microseconds, close					N/A	IEC 61000-4-5 ^[33] (performance criteria B)
	Microseconds, distant					N/A	IEC 61000-4-5 ^[33] (performance criteria B)
	Milliseconds						No standard
HF-conducted oscillatory transients	High frequency	10	A			-	IEC 61000-4-12 ^[36] (performance criteria B)
			1			1	
			2			2	
			3			3	
			4			-	
			X			X	
	Medium frequency					N/A	
	Low frequency						No standard
HF-radiated oscillatory	9 kHz to 27 MHz any source 27 MHz band CB Amateur radio all bands 27 MHz to 1 000 MHz portable except CB 27 MHz to 1 000 MHz mobile except CB 27 MHz to 1 000 MHz all others 1 GHz to 40 GHz all sources	11				N/A	
HF-radiated Pulsed	Lightning, distant power-system related	12				N/A	
ESD	Slow	13				N/A	
	Fast	14					

^a The test standard suggested either does not satisfy the frequency range and/or does not satisfy the amplitude as per the disturbance degrees defined in previous subclauses of this annex. They are, however, the nearest or only published standard to test for the referenced phenomena.

^b Change of level at 4 MHz.

^c Change of level at 4 MHz then 13,5 MHz.

Bibliography

- [1] ANSI/SAE J517-JUN94, *Hydraulic hose*
- [2] ANSI 1014:1987, Section 7, *IEEE standard for a versatile backplane bus: VME bus*
- [3] AODC (Association of Offshore Diving Contractors), *Code of practice for the safe use of electricity under water*
- [4] ISO 10417, *Petroleum and natural gas industries — Subsurface safety valve systems — Design, installation, operation and redress*
- [5] ISO 10418, *Petroleum and natural gas industries — Offshore production installations — Basic surface process safety systems*
- [6] ISO 13628-1, *Petroleum and natural gas industries — Design and operation of subsea production systems — Part 1: General requirements and recommendations*
- [7] ISO 13628-7, *Petroleum and natural gas industries — Design and operation of subsea production systems — Part 7: Completion/workover riser systems*
- [8] API Spec 6A, *Specification for Wellhead and Christmas Tree Equipment*
- [9] API Spec 17D, *Specification for Subsea Wellhead and Christmas Tree Equipment*
- [10] API Spec 17E, *Specification for Subsea Umbilicals*
- [11] ASTM D1293, *Standard Test Methods for pH of Water*
- [12] ASTM D2596, *Standard Test Method for Measurement of Extreme-Pressure Properties of Lubricating Grease (Four-Ball Method)*
- [13] ASTM D4172, *Standard Test Method for Wear Preventive Characteristics of Lubricating Fluid (Four-Ball Method)*
- [14] ASTM D5706, *Standard Test Method for Determining Extreme Pressure Properties of Lubricating Greases Using a High-Frequency, Linear-Oscillation (SRV) Test Machine*
- [15] ASTM D5707, *Standard Test Method for Measuring Friction and Wear Properties of Lubricating Grease Using a High-Frequency, Linear-Oscillation (SRV) Test Machine*
- [16] AWS D1.1, *Structural welding code for steel*
- [17] BS 7201-2, *Hydraulic Fluid Power — Gas-Loaded Accumulators — Part 2: Dimensions of Gas Ports*
- [18] EN 288 (all parts), *Specification and approval of welding procedures for metallic materials*
- [19] IEC 60529:1989, *Degrees of protection provided by enclosures (IP code)*
- [20] IEC/TS 60479-1:1994, *Effects of current on human beings and livestock — Part 1: General aspects*
- [21] IEC/TR 60479-2:1987, *Effects of current passing through the human body. Part 2: Special aspects — Chapter 4: Effects of alternating current with frequencies above 100 Hz — Chapter 5: Effects of special waveforms of current — Chapter 6: Effects of unidirectional single impulse currents of short duration*
- [22] IEC 60533, *Electrical and electronic installations in ships — Electromagnetic compatibility*

- [23] IEC 60870-5-1:1990, *Telecontrol equipment and systems — Part 5: Transmission protocols — Section 1: Transmission frame formats*
- [24] IEC 60870-5-2:1992, *Telecontrol equipment and systems — Part 5: Transmission protocols — Section 2: Link transmission procedures*
- [25] IEC 60870-5-3:1992, *Telecontrol equipment and systems — Part 5: Transmission protocols — Section 3: General structure of application data*
- [26] IEC 60945:2002, *Maritime navigation and radiocommunication equipment and systems — General requirements — Methods of testing and required test results*
- [27] IEC 61000-2 (all sections), *Electromagnetic compatibility (EMC) — Part 2: Environment*
- [28] IEC/TS 61000-1-2, *Electromagnetic compatibility (EMC) — Part 1-2: General — Methodology for the achievement of the functional safety of electrical and electronic equipment with regard to electromagnetic phenomena*
- [29] IEC/TS 61000-2-5:1995, *Electromagnetic compatibility (EMC) — Part 2-5: Environment — Section 5: Classification of electromagnetic environments*
- [30] IEC 61000-3-2, *Electromagnetic compatibility (EMC) — Part 3-2: Limits — Limits for harmonic current emissions (equipment input current ≤ 16 A per phase)*
- [31] IEC/TS 61000-3-4, *Electromagnetic compatibility (EMC) — Part 3-4: Limits — Limitation of emission of harmonic currents in low-voltage power supply systems for equipment with rated current greater than 16 A*
- [32] IEC 61000-4-4, *Electromagnetic compatibility (EMC) — Part 4-4: Testing and measurement techniques — Electrical fast transient/burst immunity test*
- [33] IEC 61000-4-5, *Electromagnetic compatibility (EMC) — Part 4-5: Testing and measurement techniques — Surge immunity test*
- [34] IEC 61000-4-6, *Electromagnetic compatibility (EMC) — Part 4-6: Testing and measurement techniques — Immunity to conducted disturbances, induced by radio-frequency fields*
- [35] IEC 61000-4-8, *Electromagnetic compatibility (EMC) — Part 4-8: Testing and measurement techniques — Power frequency magnetic field immunity test*
- [36] IEC 61000-4-12, *Electromagnetic compatibility (EMC) — Part 4-12: Testing and measurement techniques — Oscillatory waves immunity test*
- [37] IEC 61000-4-13, *Electromagnetic compatibility (EMC) — Part 4-13: Testing and measurement techniques — Harmonics and interharmonics including mains signalling at a.c. power port, low frequency immunity tests*
- [38] IEC 61000-4-16, *Electromagnetic compatibility (EMC) — Part 4-16: Testing and measurement techniques — Test for immunity to conducted, common mode disturbances in the frequency range 0 Hz to 150 KHz*
- [39] IEC 61511-SER, *Functional safety — Safety instrumented systems for the process industry sector*
- [40] IEC 61508-SER (all parts), *Functional safety of electrical/electronic/programmable electronic safety-related systems*
- [41] ISO 3511 (all parts), *Process measurement control functions and instrumentation — Symbolic representation*

- [42] EN 10025, *Hot rolled products of non-alloy structural steels — Technical delivery conditions (includes amendment A1:1993)*
- [43] ISO 13357-2, *Petroleum products — Determination of the filterability of lubricating oils — Part 2: Procedure for dry oils*
- [44] MIL-STD-217, *Reliability prediction of electrical equipment*
- [45] MIL-STD-2000, *Standard requirements for soldered electrical and electronic assemblies*
- [46] National Electrical Code Handbook (latest edition), National Fire Prevention Association, or appropriate national standards
- [47] Oslo and Paris Commission (OSPAR) Guidelines — *OSPAR Guidelines for toxicity testing of substances and preparations used and discharged offshore*, (Reference number: 2002-3)
- [48] PD 5500, *Specification for unfired fusion welded pressure vessels*
- [49] PRD 0000021632, *Acceptance Test for Water Based Fluids*
- [50] SSPC — SP — 10, *Structural Steel Painting Council — Surface preparation — 10*
- [51] AS 4059, *Aerospace fluid power — Cleanliness classification for hydraulic fluids*
- [52] EN 287-1, *Qualification test of welders — Fusion welding — Part 1: Steels*
- [53] DNV (Det Norske Veritas) New Offshore Reliability Data handbook (OREDA), 2003
- [54] ISO 6073 (all parts), *Petroleum products — Prediction of bulk moduli of petroleum fluids used in hydraulic power systems*

BSI — British Standards Institution

BSI is the independent national body responsible for preparing British Standards. It presents the UK view on standards in Europe and at the international level. It is incorporated by Royal Charter.

Revisions

British Standards are updated by amendment or revision. Users of British Standards should make sure that they possess the latest amendments or editions.

It is the constant aim of BSI to improve the quality of our products and services. We would be grateful if anyone finding an inaccuracy or ambiguity while using this British Standard would inform the Secretary of the technical committee responsible, the identity of which can be found on the inside front cover.
Tel: +44 (0)20 8996 9000. Fax: +44 (0)20 8996 7400.

BSI offers members an individual updating service called PLUS which ensures that subscribers automatically receive the latest editions of standards.

Buying standards

Orders for all BSI, international and foreign standards publications should be addressed to Customer Services. Tel: +44 (0)20 8996 9001.
Fax: +44 (0)20 8996 7001. Email: orders@bsi-global.com. Standards are also available from the BSI website at <http://www.bsi-global.com>.

In response to orders for international standards, it is BSI policy to supply the BSI implementation of those that have been published as British Standards, unless otherwise requested.

Information on standards

BSI provides a wide range of information on national, European and international standards through its Library and its Technical Help to Exporters Service. Various BSI electronic information services are also available which give details on all its products and services. Contact the Information Centre.
Tel: +44 (0)20 8996 7111. Fax: +44 (0)20 8996 7048. Email: info@bsi-global.com.

Subscribing members of BSI are kept up to date with standards developments and receive substantial discounts on the purchase price of standards. For details of these and other benefits contact Membership Administration.
Tel: +44 (0)20 8996 7002. Fax: +44 (0)20 8996 7001.
Email: membership@bsi-global.com.

Information regarding online access to British Standards via British Standards Online can be found at <http://www.bsi-global.com/bsonline>.

Further information about BSI is available on the BSI website at <http://www.bsi-global.com>.

Copyright

Copyright subsists in all BSI publications. BSI also holds the copyright, in the UK, of the publications of the international standardization bodies. Except as permitted under the Copyright, Designs and Patents Act 1988 no extract may be reproduced, stored in a retrieval system or transmitted in any form or by any means – electronic, photocopying, recording or otherwise – without prior written permission from BSI.

This does not preclude the free use, in the course of implementing the standard, of necessary details such as symbols, and size, type or grade designations. If these details are to be used for any other purpose than implementation then the prior written permission of BSI must be obtained.

Details and advice can be obtained from the Copyright & Licensing Manager.
Tel: +44 (0)20 8996 7070. Fax: +44 (0)20 8996 7553.
Email: copyright@bsi-global.com.

BSI
389 Chiswick High Road
London
W4 4AL