

# Petroleum and natural gas industries — Design and operation of subsea production systems —

## Part 10: Specification for bonded flexible pipe

The European Standard EN ISO 13628-10:2006 has the status of a  
British Standard

ICS 75.180.10

## National foreword

This British Standard was published by BSI. It is the UK implementation of EN ISO 13628-10:2006. It is identical with ISO 13628-10:2005.

The UK participation in its preparation was entrusted by Technical Committee PSE/17, Materials and equipment for petroleum, petrochemical and natural gas industries, to Subcommittee PSE/17/-/4, Drilling and production equipment.

A list of organizations represented on PSE/17/-/4 can be obtained on request to its secretary.

This publication does not purport to include all the necessary provisions of a contract. Users are responsible for its correct application.

**Compliance with a British Standard cannot confer immunity from legal obligations.**

### Amendments issued since publication

Amd. No.	Date	Comments
16775	29 December 2006	Renumbers BS ISO 13628-10:2005 as BS EN ISO 13628-10:2006

This British Standard was published under the authority of the Standards Policy and Strategy Committee on 12 January 2006

© BSI 2006

ISBN 0 580 47167 5

ICS 75.180.10

English Version

**Petroleum and natural gas industries - Design and operation of  
subsea production systems - Part 10: Specification for bonded  
flexible pipe (ISO 13628-10:2005)**

Industries du pétrole et du gaz naturel - Conception et  
exploitation des systèmes de production immergés - Partie  
10: Spécification pour canalisations flexibles composites  
(ISO 13628-10:2005)

Erdöl- und Erdgasgewinnung - Konstruktion und Betrieb  
von Unterwasser-Produktionssystemen - Teil 10:  
Anforderungen an miteinander verklebte Leitungen (ISO  
13628-10:2005)

This European Standard was approved by CEN on 6 October 2006.

CEN members are bound to comply with the CEN/CENELEC Internal Regulations which stipulate the conditions for giving this European Standard the status of a national standard without any alteration. Up-to-date lists and bibliographical references concerning such national standards may be obtained on application to the Central Secretariat or to any CEN member.

This European Standard exists in three official versions (English, French, German). A version in any other language made by translation under the responsibility of a CEN member into its own language and notified to the Central Secretariat has the same status as the official versions.

CEN members are the national standards bodies of Austria, Belgium, Cyprus, Czech Republic, Denmark, Estonia, Finland, France, Germany, Greece, Hungary, Iceland, Ireland, Italy, Latvia, Lithuania, Luxembourg, Malta, Netherlands, Norway, Poland, Portugal, Romania, Slovakia, Slovenia, Spain, Sweden, Switzerland and United Kingdom.



EUROPEAN COMMITTEE FOR STANDARDIZATION  
COMITÉ EUROPÉEN DE NORMALISATION  
EUROPÄISCHES KOMITEE FÜR NORMUNG

**Management Centre: rue de Stassart, 36 B-1050 Brussels**

## Foreword

The text of ISO 13628-10:2005 has been prepared by Technical Committee ISO/TC 67 "Materials, equipment and offshore structures for petroleum and natural gas industries" of the International Organization for Standardization (ISO) and has been taken over as EN ISO 13628-10:2006 by Technical Committee CEN/TC 12 "Materials, equipment and offshore structures for petroleum, petrochemical and natural gas industries", the secretariat of which is held by AFNOR.

This European Standard shall be given the status of a national standard, either by publication of an identical text or by endorsement, at the latest by April 2007, and conflicting national standards shall be withdrawn at the latest by April 2007.

According to the CEN/CENELEC Internal Regulations, the national standards organizations of the following countries are bound to implement this European Standard: Austria, Belgium, Cyprus, Czech Republic, Denmark, Estonia, Finland, France, Germany, Greece, Hungary, Iceland, Ireland, Italy, Latvia, Lithuania, Luxembourg, Malta, Netherlands, Norway, Poland, Portugal, Romania, Slovakia, Slovenia, Spain, Sweden, Switzerland and United Kingdom.

### Endorsement notice

The text of ISO 13628-10:2005 has been approved by CEN as EN ISO 13628-10:2006 without any modifications.

INTERNATIONAL  
STANDARD

ISO  
13628-10

First edition  
2005-10-01

---

---

**Petroleum and natural gas industries —  
Design and operation of subsea  
production systems —**

**Part 10:  
Specification for bonded flexible pipe**

*Industries du pétrole et du gaz naturel — Conception et exploitation des  
systèmes de production immergés —*

*Partie 10: Spécification pour canalisations flexibles composites*



Reference number  
ISO 13628-10:2005(E)

.....

# Contents

Page

Foreword.....	v
Introduction .....	vi
1 Scope .....	1
1.1 Purpose.....	1
1.2 Products .....	2
1.3 Applications .....	2
2 Normative references .....	2
3 Terms, definitions and abbreviations .....	5
3.1 Terms and definitions.....	5
3.2 Symbols and abbreviations .....	10
4 Functional requirements .....	11
4.1 General.....	11
4.2 Overall requirements .....	11
4.3 General design parameters .....	12
4.4 Internal fluid parameters .....	12
4.5 External environment .....	14
4.6 System requirements .....	14
5 Design requirements .....	17
5.1 Loads and load effects .....	17
5.2 Pipe design methodology .....	20
5.3 Pipe structure design .....	21
5.4 System design requirements.....	26
6 Materials .....	29
6.1 Material requirements.....	29
6.2 Qualification requirements .....	33
6.3 Quality assurance requirements .....	39
7 Manufacturing requirements .....	41
7.1 Quality assurance requirements .....	41
7.2 Carcass .....	42
7.3 Preparation of compound and calendering .....	43
7.4 Elastomer winding .....	44
7.5 Reinforcement armour layer .....	45
7.6 Insulation layers.....	45
7.7 End fitting .....	45
7.8 Curing process.....	47
7.9 Special processes.....	48
7.10 Manufacturing tolerances .....	50
7.11 Repairs .....	50
8 Documentation .....	51
8.1 General.....	51
8.2 Design premise .....	51
8.3 Design load report .....	51
8.4 Design report.....	51
8.5 Manufacturing quality plan .....	52
8.6 Fabrication specification .....	52
8.7 As-built documentation.....	52
8.8 Operation manual .....	53

# EN ISO 13628-10:2006

<b>9</b>	<b>Factory acceptance tests .....</b>	<b>54</b>
<b>9.1</b>	<b>General .....</b>	<b>54</b>
<b>9.2</b>	<b>Gauge test .....</b>	<b>55</b>
<b>9.3</b>	<b>Hydrostatic pressure test .....</b>	<b>55</b>
<b>9.4</b>	<b>Electrical continuity and resistance tests .....</b>	<b>56</b>
<b>9.5</b>	<b>Kerosene test .....</b>	<b>56</b>
<b>9.6</b>	<b>Vacuum test .....</b>	<b>56</b>
<b>10</b>	<b>Marking and packaging .....</b>	<b>57</b>
<b>10.1</b>	<b>Marking .....</b>	<b>57</b>
<b>10.2</b>	<b>Packaging .....</b>	<b>57</b>
<b>Annex A</b>	<b>(informative) Purchasing guidelines .....</b>	<b>59</b>
<b>Annex B</b>	<b>(informative) Bend stiffeners and bend restrictors .....</b>	<b>66</b>
<b>Annex C</b>	<b>(informative) Use of the API Monogram .....</b>	<b>71</b>
<b>Bibliography</b>	<b>.....</b>	<b>72</b>



## Foreword

ISO (the International Organization for Standardization) is a worldwide federation of national standards bodies (ISO member bodies). The work of preparing International Standards is normally carried out through ISO technical committees. Each member body interested in a subject for which a technical committee has been established has the right to be represented on that committee. International organizations, governmental and non-governmental, in liaison with ISO, also take part in the work. ISO collaborates closely with the International Electrotechnical Commission (IEC) on all matters of electrotechnical standardization.

International Standards are drafted in accordance with the rules given in the ISO/IEC Directives, Part 2.

The main task of technical committees is to prepare International Standards. Draft International Standards adopted by the technical committees are circulated to the member bodies for voting. Publication as an International Standard requires approval by at least 75 % of the member bodies casting a vote.

Attention is drawn to the possibility that some of the elements of this document may be the subject of patent rights. ISO shall not be held responsible for identifying any or all such patent rights.

ISO 13628-10 was prepared by Technical Committee ISO/TC 67, *Materials, equipment and offshore structures for petroleum, petrochemical and natural gas industries*, Subcommittee SC 4, *Drilling and production equipment*.

ISO 13628 consists of the following parts, under the general title *Petroleum and natural gas industries — Design and operation of subsea production systems*:

- *Part 1: General requirements and recommendations*
- *Part 2: Unbonded flexible pipe systems for subsea and marine applications*
- *Part 3: Through flowline (TFL) systems*
- *Part 4: Subsea wellhead and tree equipment*
- *Part 5: Subsea umbilicals*
- *Part 6: Subsea production control systems*
- *Part 7: Completion/workover riser systems*
- *Part 8: Remotely Operated Vehicle (ROV) interfaces on subsea production systems*
- *Part 9: Remotely Operated Tool (ROT) intervention system*
- *Part 10: Specification for bonded flexible pipe*
- *Part 11: Flexible pipe systems for subsea and marine riser applications*

The following part is under preparation:

- *Part 12: Dynamic production risers*

## **Introduction**

This part of ISO 13628 has been based on API Spec 17K, First Edition, September 2001.

Users of this International Standard should be aware that further or differing requirements might be needed for individual applications. This International Standard is not intended to inhibit a vendor from offering, or the purchaser from accepting, alternative equipment or engineering solutions for the individual application. This may be particularly applicable where there is innovative or developing technology. Where an alternative is offered, the vendor should identify any variations from this International Standard and provide details.

# Petroleum and natural gas industries — Design and operation of subsea production systems —

## Part 10: Specification for bonded flexible pipe

### 1 Scope

#### 1.1 Purpose

1.1.1 This part of ISO 13628 defines the technical requirements for safe, dimensionally and functionally interchangeable bonded flexible pipes that are designed and manufactured to uniform standards and criteria. See Figure 1 for explanatory figure on typical bonded flexible pipe.

1.1.2 Minimum requirements are specified for the design, material selection, manufacture, testing, marking and packaging of bonded flexible pipes, with reference to existing codes and standards where applicable. See API RP 17B for guidelines on the use of flexible pipes and ancillary components.

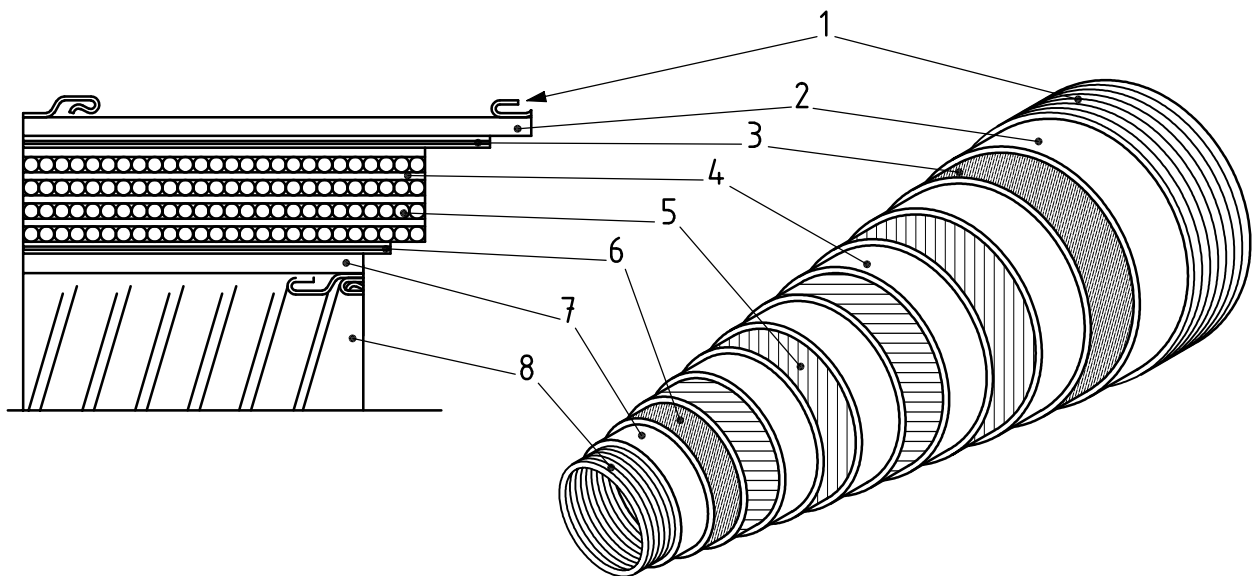

#### Key

- |   |               |   |                     |
|---|---------------|---|---------------------|
| 1 | outer wrap    | 5 | reinforcement layer |
| 2 | cover         | 6 | breaker layer       |
| 3 | breaker layer | 7 | liner               |
| 4 | cushion layer | 8 | carcass             |

Figure 1 — Typical bonded flexible pipe

## 1.2 Products

**1.2.1** This part of ISO 13628 applies to bonded flexible pipe assemblies, consisting of segments of flexible pipe body with end fittings attached to both ends. This part of ISO 13628 does not cover flexible pipes of unbonded structure. See ISO 13628-2 for guidance on unbonded flexible pipes.

NOTE For the purposes of this provision, API Spec 17J<sup>[10]</sup> is equivalent to ISO 13628-2.

**1.2.2** This part of ISO 13628 does not apply to flexible pipe ancillary components. Guidelines for ancillary components are given in API RP 17B.

**1.2.3** This part of ISO 13628 can be applied to flexible pipes that include non-metallic reinforcing layers, though no effort was made to address the specific and unique technological aspects of this product.

**1.2.4** This part of ISO 13628 can be applied to a bonded construction pipe that includes a material or layer construction that is covered in ISO 13628-2.

NOTE For the purposes of this provision, API Spec 17J<sup>[10]</sup> is equivalent to ISO 13628-2.

## 1.3 Applications

**1.3.1** The applications addressed by this part of ISO 13628 are sweet and sour service production, including export and injection applications. Production products include oil, gas, water and injection chemicals. This part of ISO 13628 applies to both static and dynamic flexible pipes used as flowlines, risers, jumpers and offshore loading and discharge hoses. This part of ISO 13628 applies to pipes with a design pressure greater than or equal to 1,5 MPa (15 bar). This part of ISO 13628 can be used for lower design pressure pipes, though the requirements of these pipes have not been specifically addressed. Reference OCIMF<sup>[30]</sup> for guidelines on these pipes.

**1.3.2** This part of ISO 13628 does not apply to flexible pipes for use in choke and kill line applications. See API Spec 16C for guidance on choke and kill line applications. This part of ISO 13628 can be applied to flexible pipes for pile hammer, gas flare, water supply and jetting applications, though no effort was made to address the specific and unique technological aspects relating to each of these requirements.

## 2 Normative references

The following referenced documents are indispensable for the application of this document. For dated references, only the edition cited applies. For undated references, the latest edition of the referenced document (including any amendments) applies.

ISO 34-2, *Rubber, vulcanized or thermoplastic — Determination of tear strength — Part 2: Small (Delft) test pieces*

ISO 37, *Rubber, vulcanized or thermoplastic — Determination of tensile stress-strain properties*

ISO 75 (all parts), *Plastics — Determination of temperature of deflection under load*

ISO 812, *Rubber, vulcanized — Determination of low-temperature brittleness*

ISO 868, *Plastics and ebonite — Determination of indentation hardness by means of a durometer (Shore hardness)*

ISO 1431-1:2004, *Rubber, vulcanized or thermoplastic — Resistance to ozone cracking — Part 1: Static and dynamic strain testing*

ISO 1817, *Rubber, vulcanized — Determination of the effect of liquids*

ISO 2781, *Rubber, vulcanized — Determination of density*

ISO 4647:1982, *Rubber, vulcanized — Determination of static adhesion to textile cord — H-pull test*

ISO 4649, *Rubber, vulcanized or thermoplastic — Determination of abrasion resistance using a rotating cylindrical drum device*

ISO 6506-1, *Metallic materials — Brinell hardness test — Part 1: Test method*

ISO 6508-1, *Metallic materials — Rockwell hardness test — Part 1: Test method (scales A, B, C, D, E, F, G, H, K, N, T)*

ISO 6892, *Metallic materials — Tensile testing at ambient temperature*

ISO 10423, *Petroleum and natural gas industries — Drilling and production equipment — Wellhead and christmas tree equipment*

ISO 10474, *Steel and steel products — Inspection documents*

ISO 13628-4, *Petroleum and natural gas industries — Design and operation of subsea production systems — Part 4: Subsea wellhead and tree equipment*

ISO 13665, *Seamless and welded steel tubes for pressure purposes — Magnetic particle inspection of the tube body for the detection of surface imperfections*

ISO 15156 (all parts), *Petroleum and natural gas industries — Materials for use in H<sub>2</sub>S-containing environments in oil and gas production*

ISO 16120-1, *Non-alloy steel wire rod for conversion to wire — Part 1: General requirements*

API RP 17B, *Recommended Practice for Flexible Pipe*

API<sup>1)</sup> Standard 1104, *Welding of Pipelines and Related Facilities*

ASME<sup>2)</sup> Section IX, Boiler & Pressure Vessel Code, *Welding and Brazing Qualifications*

ASTM<sup>3)</sup> A29/A29M:2005, *Standard Specification for Steel Bars, Carbon and Alloy, Hot-Wrought — General Requirements for*

ASTM A182/A182M:2005, *Standard Specification for Forged or Rolled Alloy-Steel Pipe Flanges, Forged Fittings, and Valves and Parts for High Temperature Service*

ASTM A388, *Standard Practice for Ultrasonic Examination of Heavy Steel Forgings*

ASTM A668/A668M:2004, *Standard Specification for Steel Forgings, Carbon and Alloy, for General Industrial Use*

ASTM A751, *Standard Test Methods, Practices, and Terminology for Chemical Analysis of Steel Products*

ASTM C177, *Standard Test Method for Steady-State Heat Flux Measurements and Thermal Transmission Properties by Means of the Guarded-Hot-Plate Apparatus*

---

1) American Petroleum Institute, 1220 L St NW, Washington DC 20005, USA.

2) American Society of Mechanical Engineers.

3) American Society for Testing and Materials.

## EN ISO 13628-10:2006

ASTM D256, *Standard Test Methods for Determining the Izod Pendulum Impact Resistance of Plastics*

ASTM D395, *Standard Test Methods for Rubber Property — Compression Set*

ASTM D412, *Standard Test Methods for Vulcanized Rubber and Thermoplastic Rubbers and Thermoplastic Elastomers — Tension*

ASTM D413, *Standard Test Methods for Rubber Property — Adhesion to Flexible Substrate*

ASTM D570, *Standard Test Method for Water Absorption of Plastics*

ASTM D664, *Standard Test Method for Acid Number of Petroleum Products by Potentiometric Titration*

ASTM D695, *Standard Test Method for Compressive Properties of Rigid Plastics*

ASTM D746, *Standard Test Method for Brittleness Temperature of Plastics and Elastomers by Impact*

ASTM D974, *Standard Test Method for Acid and Base Number by Color-Indicator Titration*

ASTM D1418, *Standard Practice for Rubber and Rubber Lattices — Nomenclature*

ASTM D2084, *Standard Test Method for Rubber Property — Vulcanization Using Oscillating Disk Cure Meter*

ASTM D2583, *Standard Test Method for Indentation Hardness of Rigid Plastics by Means of a Barcol Impressor*

ASTM D5028, *Standard Test Method for Curing Properties of Pultrusion Resins by Thermal Analysis*

ASTM E92, *Standard Test Method for Vickers Hardness of Metallic Materials*

ASTM E94, *Standard Guide for Radiographic Examination*

ASTM E165, *Standard Test method for Liquid Penetrant Examination*

ASTM E328, *Standard Test Methods for Stress Relaxation Tests for Materials and Structures*

ASTM E428, *Standard Practice for Fabrication and Control of Steel Reference Blocks Used in Ultrasonic Examination*

ASTM E1356, *Standard Test Method for Assignment of the Glass Transition Temperatures by Differential Scanning Calorimetry*

ASTM G48, *Standard Test Method for Pitting and Crevice Corrosion Resistance of Stainless Steels and Related Alloys by Use of Ferric Chloride Solution*

ISO 36, *Rubber, vulcanized or thermoplastic — Determination of adhesion to textile fabrics*

DNV<sup>4)</sup> Fire Test, *DNV Classification Note 6.1 Test (Fire Test)*

DIN<sup>5)</sup> 53505, *Shore A and Shore D hardness testing of rubber*

DIN 53516, *Testing of rubber and elastomers; determination of abrasion resistance*

EN<sup>6)</sup> 287-1, *Qualification test of welders — Fusion welding — Part 1: Steels*

---

4) Det Norske Veritase.

5) Deutsches Institut für Normung e.V.

6) European Committee for Standardization.

EN 288-1, *Specification and approval of welding procedures for metallic materials — Part 1: General rules for fusion welding*

EN 288-2, *Specification and approval of welding procedures for metallic materials — Part 2: Welding procedure specification for arc welding*

EN 288-3, *Specification and approval of welding procedures for metallic materials — Part 3: Welding procedure tests for the arc welding of steels*

EN 10204, *Metallic products — Types of inspection documents*

Lloyds Fire Test, *Lloyds Register of Shipping, Fire Testing Memorandum ICE/Fire OSG 1000/499*

NACE TM0177, *Laboratory Testing of Metals for Resistance to Sulfide Stress Cracking and Stress Corrosion Cracking in H<sub>2</sub>S Environments*

### 3 Terms, definitions and abbreviations

#### 3.1 Terms and definitions

For the purposes of this document, the following terms and definitions apply.

##### 3.1.1 ancillary components

components used to control the flexible pipe behaviour, such as buoyancy aids and fire hoods/boxes

##### 3.1.2 API Monogram

registered mark of the American Petroleum Institute

##### 3.1.3 bellmouth

part of a guide tube, formed in the shape of a bellmouth, and designed to prevent overbending of the flexible pipe

##### 3.1.4 bend limiter

any device used to restrict bending of the flexible pipe

NOTE Bend limiters include bend restrictors, bend stiffeners and bellmouths.

##### 3.1.5 bend radius

radius of curvature of the flexible pipe measured from the pipe centreline

NOTE Storage and operating minimum bend radii are defined in 5.3.1.6 and 5.3.1.7.

##### 3.1.6 bend restrictor

mechanical device that functions as a mechanical stop and limits the local radius of curvature of the flexible pipe to a minimum value

##### 3.1.7 bend stiffener

ancillary conically shaped component, which locally supports the pipe to limit bending stresses and curvature of the pipe to acceptable levels

NOTE Bend stiffeners can be either attached to an end fitting or a support structure where the flexible pipe passes through the bend stiffener.

**3.1.8**  
**bending stiffness**

analogous to the structural stiffness of a rigid beam or pipe (modulus of elasticity times the second area moment of inertia), except that it can vary to a large extent with temperature and pressure

NOTE It is often quantified as the product of an applied bending moment times the resultant bend radius of the pipe.

**3.1.9**  
**bonded pipe**

flexible pipe where the steel reinforcement is integrated and bonded to a vulcanized elastomeric material

NOTE Textile material is included in the structure to obtain additional structural reinforcement or to separate elastomeric layers.

**3.1.10**  
**breaker**

textile layer impregnated with rubber included in various layers in the pipe cross-section to give additional strength to the pipe, to aid in reducing propagation of cuts in the pipe and to aid the manufacturing process

NOTE This layer can be incorporated into either or all of the cover, reinforcing layer and liner.

**3.1.11**  
**cable**

series of round wires of steel or fabric (circular cross-section) spirally wound (stranded) together and used for structurally reinforcing the pipe

NOTE Cable wires for flexible pipes are usually brass or copper coated to promote chemical bonding of the elastomer to the wires.

**3.1.12**  
**calendering**

process of passing elastomer compound between rollers to produce smooth sheets of elastomer

NOTE This process is also used to cover reinforcing cables and textiles with elastomer to form sheets for winding onto pipes.

**3.1.13**  
**carcass**

interlocked metallic construction that can be used as the innermost layer to prevent, totally or partially, collapse of the pipe due to pipe decompression, external pressure, reinforcement layer pressure and mechanical crushing loads

NOTE It can be used externally to protect the external surface of the pipe.

**3.1.14**  
**choke and kill line**

flexible pipe jumper located between choke manifold and blow-out preventer

**3.1.15**  
**compound**

mix of elastomer material and various additives immediately prior to the curing process

**3.1.16**  
**connector**

device used to provide a leak-tight structural connection between the end fitting and adjacent piping

NOTE Connectors include bolted flanges, clamped hubs and proprietary connectors. They can be designed for diver-assisted makeup or for diverless operation using either mechanical or hydraulic apparatus.



**3.1.17****cover**

layer of elastomer between the reinforcing layer and the external environment (or external carcass if provided) used to protect the pipe against penetration of seawater and other external environments, corrosion, abrasion and mechanical damage

**3.1.18****crossover**

flexible flowline crossing another pipe already laid on the seabed

NOTE The underlying pipe may be a steel pipe or another flexible pipe. It may be required to support the overlying pipe to prevent overbending or crushing of the new or existing pipes.

**3.1.19****curing**

process of changing irreversibly, usually at elevated temperatures, the properties of a thermosetting resin or an elastomer compound by chemical reaction

NOTE Cure can be accomplished by the addition of curing (cross-linking) agents, with or without heat and pressure.

**3.1.20****design pressure**

minimum or maximum pressure, inclusive of operating pressure, surge pressure including shut-in pressure where applicable, vacuum conditions and static pressure head

**3.1.21****dynamic application**

service in which flexible pipe is exposed to cyclically varying loads and deflections during normal operation

NOTE The pipe is specially constructed to withstand a large number of bending/tensile/torsional cycles.

**3.1.22****elastomer**

material that substantially recovers its original shape and size at room temperature after removal of a deforming force; material that shows a reversible elasticity up to a very high strain level (~ 100 %)

**3.1.23****embedding compound**

elastomeric compound in which the steel reinforcing cables are embedded

NOTE The compound assures bonding between the steel cables and surrounding layers.

**3.1.24****end fitting**

mechanical device which forms the transition between the flexible pipe body and the connector

NOTE The different pipe layers are terminated in the end fitting in such a way as to transfer the load between the flexible pipe and the connector.

**3.1.25****flexible flowline**

flexible pipe, wholly or in part, resting on the seafloor or buried below the seafloor, and used in a static application

NOTE The term flowline is used in this document as a generic term for flexible flowlines.

**3.1.26****flexible pipe**

assembly of a pipe body and end fittings

NOTE The pipe body comprises a composite of layered materials that form a pressure-containing conduit. The pipe structure allows large deflections without a significant increase in bending stresses. Normally, the pipe body is built up as a composite structure comprising metallic and elastomer layers. The term *pipe* is used in this document as a generic term for flexible pipe.

**3.1.27**

**flexible riser**

flexible pipe connecting a platform/buoy/ship to a flowline, seafloor installation or another platform

NOTE The riser can be freely suspended (free catenary), restrained to some extent (buoys, chains), totally restrained or enclosed in a tube (I- or J-tube).

**3.1.28**

**floating loading and discharge hose**

flexible pipe with integral buoyancy or clamped-on buoyancy modules so as to enable the buoyancy pipe to float on the water surface

**3.1.29**

**gas service**

service conditions with a gas content, i.e. gas applications or live crude containing gas

**3.1.30**

**independent verification agent**

independent party or group, selected by the manufacturer, that can verify the indicated methodologies or performance, based on the technical literature, analyses, test results, and other information provided by the manufacturer

NOTE The agent is also called upon to witness some measurements and tests related to material qualification.

**3.1.31**

**insulation layer**

additional layer added to the flexible pipe to increase the thermal insulation properties

NOTE The layer is usually located between the outer reinforcement layer and the cover.

**3.1.32**

**jumper**

short flexible pipe used in subsea and topside, static or dynamic applications, e.g. turret jumpers and drag chain jumpers

**3.1.33**

**lay angle**

angle between the axis of a spiral wound element (e.g. cables of reinforcing layer) and a line parallel to the longitudinal axis of the flexible pipe

**3.1.34**

**liner**

layer of elastomer in contact with the internal fluid which ensures internal fluid integrity

**3.1.35**

**loading and discharge hose**

flexible pipe jumper used in the loading and offloading of tankers in both static and dynamic applications

**3.1.36**

**piggyback**

two pipes attached at regular intervals with clamps

NOTE Either or both of the pipes can be flexibles.

**3.1.37**

**quality**

conformance to specified requirements

**3.1.38****quality assurance**

those planned, systematic corrective and preventive actions which are required to ensure that materials, products or services will meet specified requirements

**3.1.39****quality control**

inspection, test or examination to ensure that materials, products or services conform to specified requirements

**3.1.40****quality programme**

established documented system to ensure quality

**3.1.41****reinforcing layer**

structural layer with a specific lay angle, typically around 55°, which consists of helically wound cables embedded in elastomer, and is used to sustain, totally or partially, tensile loads and internal pressure

**3.1.42****rough bore**

flexible pipe with a steel strip carcass as the innermost layer

**3.1.43****service life**

period of time during which the flexible pipe fulfils all performance requirements

**3.1.44****smooth bore**

flexible pipe with an elastomer layer as the innermost layer

**3.1.45****sour service**

service conditions with a H<sub>2</sub>S content exceeding the minimum specified by ISO 15156 at the design pressure

NOTE For the purposes of this provision, NACE MR0175 is equivalent to ISO 15156.

**3.1.46****static application**

flexible pipes not exposed to significant cyclically varying loads or deflections during normal operations

**3.1.47****sweet service**

service conditions which have a H<sub>2</sub>S content less than that specified by ISO 15156 at the design pressure

NOTE For the purposes of this provision, NACE MR0175 is equivalent to ISO 15156.

**3.1.48****tensile strength**

tensile strength of elastomeric materials in this part of ISO 13628 is defined in accordance with ISO 37

NOTE For the purposes of this provision, ASTM D638 is equivalent to ISO 37.

**3.1.49****torsional balance**

pipe characteristic that is achieved by designing the structural layers in the pipe, such that axial and pressure loads do not induce significant twist or torsional loads in the pipe

## 3.1.50

### **ultimate strength**

ultimate strength in this part of ISO 13628 is defined in accordance with ISO 6892

NOTE For the purposes of this provision, ASTM A370 is equivalent to ISO 6892.

## 3.1.51

### **unbonded pipe**

pipe construction consists of separate unbonded polymeric and metallic layers, which allows relative movement between layers

## 3.1.52

### **visual examination**

examination of parts and equipment for visible defects in material and workmanship

## 3.1.53

### **yield strength**

yield strength in this standard for steel materials is defined as 0,2 % yield offset strength, as specified in ISO 6892

NOTE For the purposes of this provision, ASTM A370 is equivalent to ISO 6892.

## 3.1.54

### **vulcanization**

process of cross-linking the elastomer chains to reduce the plasticity of the elastomer

NOTE Otherwise referred to as "curing".

## 3.2 Symbols and abbreviations

The following symbols and abbreviations are used in this document:

DSC	Differential scanning calorimetry
FAT	Factory acceptance test
GA	General arrangement
HIC	Hydrogen-induced cracking
HV	Hardness on Vickers Scale
ID	Internal diameter
MBR	Minimum bend radius
MPI	Magnetic particle inspection
NDE	Non-destructive examination
ODR	Oscillating disk rheometer
RAO	Response amplitude operator
S-N	Curves showing stress range vs. number of cycles
SSC	Sulfide stress cracking
TAN	Titrated acid number
TFL	Through flowline

UNS <sup>(1)</sup>	Unified National Standard
UNS <sup>(2)</sup>	Unified Numbering System
UV	Ultraviolet
$\sigma_y$	Material yield stress
$\sigma_u$	Material ultimate stress

## 4 Functional requirements

### 4.1 General

**4.1.1** The purchaser shall specify the functional requirements for the flexible pipe. The purchasing guidelines in Annex A give a sample format for the specification of the functional requirements.

**4.1.2** Functional requirements not specifically required by the purchaser which may affect the design, materials, manufacturing and testing of the pipe shall be specified by the manufacturer.

**4.1.3** Regulatory authority functional requirements that may affect the design, materials, manufacturing and testing of the pipe shall be specified by the purchaser.

**4.1.4** If the purchaser does not specify a requirement, and 4.1.2 does not apply, the manufacturer may assume that there is no requirement.

**4.1.5** If a purchaser wishes to use this part of ISO 13628 for the procurement of pipes with non-metallic reinforcing layers, that purchaser should prepare a supplemental specification with requirements for the manufacturer to meet in demonstrating by analysis and tests that the level of safety during the service life is not less than that given by this part of ISO 13628 for metallic reinforced pipes.

**4.1.6** If a purchaser wishes to purchase pipe that includes a material or layer construction that is covered in ISO 13628-2, that purchaser should prepare a supplemental specification with requirements for the manufacturer to meet in demonstrating by analysis and tests that the levels of safety are not less than those required by ISO 13628-2 and this part of ISO 13628.

### 4.2 Overall requirements

#### 4.2.1 Flexible pipe

The minimum overall functional requirements of the flexible pipe that shall be demonstrated by the manufacturer are as follows.

- a) The pipe shall provide a leak-tight conduit.
- b) The pipe shall be capable of withstanding all design loads and load combinations defined herein.
- c) The pipe shall perform its function for the specified service life.
- d) The flexible pipe materials shall be compatible with the environment to which the material is exposed.
- e) The flexible pipe materials shall conform to the corrosion control requirements specified herein.

**4.2.2 End fitting**

The manufacturer shall demonstrate that the end fitting, as a minimum, meets the same functional requirements as the flexible pipe. If relevant, this shall be demonstrated by the following.

- a) The end fitting shall provide a structural interface between the pipe and the support structure.
- b) The end fittings shall provide a structural interface between the flexible pipe and bend-limiting devices, including bend stiffeners, bend restrictors and bellmouths, such that the bend limiting devices meet their functional requirements.

**4.3 General design parameters**

The purchaser shall specify any project-specific design requirements, which may include the requirements of 4.4 to 4.6 and the following:

- a) nominal internal diameter;
- b) length and tolerances of flexible pipe, including end fittings;
- c) service life;
- d) regulatory authority requirements.

**4.4 Internal fluid parameters**

**4.4.1 General**

The purchaser shall specify the internal fluid parameters for the application. The parameters listed in Table 1 should be specified. When known, the minimum, normal and maximum conditions should be specified for the internal fluid parameters of Table 1. Expected variations in the internal fluid parameters over the service life should be specified.

**Table 1 — Internal fluid parameters**

Parameter	Comment
Internal pressure	See 4.4.2
Temperature	See 4.4.3
Fluid composition	See 4.4.4
Service definition	Sweet or sour in accordance with 4.4.4 (a)
Fluid/flow description	Fluid type and flow regime
Flow rate parameters	Flow rates, fluid density, viscosity, minimum inlet pressure and required outlet pressure
Thermal parameters	Fluid heat capacity

**4.4.2 Internal pressure**

The following internal pressures shall be specified:

- a) maximum design pressure;
- b) minimum design pressure.

The following internal pressures should be specified:

- operating pressure or pressure profile through service life;
- factory and field test pressure requirements of governing and/or certifying authorities.

#### 4.4.3 Temperature

**4.4.3.1** The following temperatures shall be specified:

- a) design minimum temperatures;
- b) design maximum temperatures.

The operating temperature or temperature profile through service life should be specified.

**4.4.3.2** The design minimum and maximum temperatures are the minimum and maximum temperatures that can be experienced by the flexible pipe throughout the service life. These design temperatures may be specified on the basis of the following minimum set of considerations:

- a) operating temperatures;
- b) upset temperatures (number and range of cycles);
- c) gas cooling effects (time/temperature curve);
- d) fluid thermal characteristics;
- e) flow characteristics;
- f) storage, transport and installation conditions.

#### 4.4.4 Fluid composition

The purchaser should specify produced fluids (composition of individual phases), injected fluids, and continual and occasional chemical treatments (dosages, exposure times, concentrations and frequency). This should be specified for all phases including storage, transport and installation conditions. In the specification of the internal fluid composition, the following should be defined:

- a) all parameters which define service conditions, including partial pressure of H<sub>2</sub>S and CO<sub>2</sub>, pH of aqueous phase, TAN (as specified in ASTM D664 or ASTM D974) and water content (produced water, seawater and free water);
- b) gases, including oxygen, hydrogen, methane and nitrogen;
- c) liquids, including oil composition and alcohols;
- d) aromatic components;
- e) corrosive agents, including bacteria, chlorides, organic acids and sulfur-bearing compounds;
- f) injected chemical products, including alcohols, and inhibitors for corrosion, hydrate, paraffin, scale and wax;
- g) solids, including sand, precipitates, scale, hydrates, wax and biofilm.

## 4.5 External environment

The purchaser should specify the project external environmental parameters. The parameters listed in Table 2 should be considered. The design water depth shall be the maximum water depth to which the pipe section may be exposed.

**Table 2 — External environment parameters**

Parameter	Comment
Location	Geographical data for the installation location
Water depth	Design water depth, variations over pipe location and tidal variations
Seawater data	Density, pH value, and minimum and maximum temperatures
Air temperature	Minimum and maximum during storage, installation and operation
Ozone exposure	Length of pipe exposed during operation and storage conditions
Soil data	Description, shear strength or angle of internal friction, friction coefficients, seabed scour, sand waves and variations along pipe route
Marine growth	Maximum values and variations along length
Ice	Maximum ice accumulation, or drifting icebergs and ice floes
Sunlight exposure	Length of pipe exposed during operation and storage conditions
Current data	As a function of water depth, direction and return period, and including the known effects of local current phenomena
Wave data	In terms of significant and maximum waves, associated periods, wave spectra, spreading functions and scatter diagrams, as a function of direction and return period
Wind data	As a function of direction, height above water level and return period

## 4.6 System requirements

### 4.6.1 Minimum system requirements

#### 4.6.1.1 General

**4.6.1.1.1** The purchaser shall specify the system functional requirements of the project. The requirements of 4.6.1.2, 4.6.1.9 and 4.6.1.10 shall be specified by the purchaser. Specification of the other system requirements defined in 4.6.1 should be considered. Annex A may be referenced for guidelines.

**4.6.1.1.2** The purchaser should specify the documentation, as listed in Clause 8, to be delivered by the manufacturer.

#### 4.6.1.2 Application definition

The flexible pipe system shall be specified as one of the following: flowline, riser, jumper, (floating) loading and discharge hose. The flexible pipe application shall be specified as either static or dynamic and the expected number of load cycles and magnitudes should be specified for dynamic cases.

#### 4.6.1.3 Corrosion protection

The corrosion protection requirements for the flexible pipe should be specified considering the following:

- a) end fitting internal and external corrosion protection;
- b) cathodic protection system for the pipe.



#### 4.6.1.4 Thermal insulation

The purchaser should specify any performance requirements of the flexible pipe for heat loss or retention. Overall heat transfer coefficients shall be based on pipe nominal ID and shall differentiate between the pipe itself and any external effects, such as soil cover for buried pipe.

#### 4.6.1.5 Gas permeation

A gas venting system is required to prevent excessive pressure build-up in the wall of the pipe. Requirements the purchaser has for the gas venting system should be specified, considering the following:

- a) allowable gas permeation rates;
- b) interface requirements;
- c) gas-monitoring system.

NOTE The requirements of 4.6.1.5 apply to pipes intended for live crude and gas service only.

#### 4.6.1.6 Pigging and TFL requirements

Any performance requirements, including ID, bend radius and end fitting transitions, for allowing tools for pigging, TFL, workover or other operations through the flexible pipe, should be specified.

#### 4.6.1.7 Fire resistance

Fire resistance requirements for the pipe design should be specified, with reference to Lloyds or DNV fire test requirements (see 5.4.6).

#### 4.6.1.8 Piggyback lines

Any piggyback requirements for the flexible pipe should be specified, including details of the piggyback pipe(s) and pipe operating conditions.

#### 4.6.1.9 Connectors

The connector requirements for both end fittings in the flexible pipe shall be specified. This shall include, as a minimum, connector type, welding specification, seal type and sizes.

#### 4.6.1.10 Interface definitions

Interface details, including but not limited to the following, shall be specified:

- a) regulations, codes and standards including definition of code breaks;
- b) geometric, dimensional and imposed loading data;
- c) purchaser-supplied installation aids and equipment;
- d) purchaser-supplied pull-in and connection tools and terminations;
- e) manufacturer scope of supply.

#### 4.6.1.11 Inspection and condition monitoring

The requirements for the manufacturer to design and implement flexible pipe inspection, monitoring and condition assessment systems and procedures should be specified.

**4.6.1.12 Installation requirements**

**4.6.1.12.1** The purchaser should specify performance requirements for installation services to be provided, considering the following as a minimum.

- a) For installation by the purchaser, the purchaser should specify any requirements on load restrictions, clamping/tensioner loads, overboarding requirements, installation tolerances and port facility limitations.
- b) For installation by the manufacturer, the purchaser should specify any requirements for season, environment, location, vessel limitations, installation tolerances, restrictions due to conflicting activities, and installation scope (including trenching, burial, testing, inspection, surveying and documentation).

**4.6.1.12.2** The purchaser should specify any requirements for recoverability and reusability of the flexible pipe within its service life.

**4.6.1.13 Exothermal chemical reaction cleaning**

The purchaser should specify the relevant parameters for the pipe-cleaning operations by means of exothermal chemical reaction, considering the following as a minimum:

- a) flow rate;
- b) pressure variation;
- c) maximum heat output;
- d) chemical composition.

**4.6.2 Static pipe parameters**

The purchaser should specify to the manufacturer the purchaser’s requirements for design and analysis of the static pipe or static jumper system additional to the requirements of Clause 5. The parameters listed in Table 3 should be considered.

**Table 3 — Static pipe parameters**

Parameter	Details
Pipe routing	Route drawings, topography, seabed/soil conditions, obstacles, installed equipment and pipelines.
Connection systems	Descriptions of upper and lower connection systems, including quick disconnection systems and buoy disconnection systems, connection angles and location tolerances.
Guides and supports	Proposed geometry of guides, I-tubes, J-tubes and bellmouths through which pipe is to be installed.
Protection requirements	Trenching, rock dumping, mattresses and extent of protection requirements over length of pipe; design impact loads, including those from trawl boards, dropped objects and anchors.
On-bottom stability	Allowable displacements.
Upheaval buckling	Specification of design cases to be considered by manufacturer.
Crossover requirements	Crossing of pipes (flexible and rigid), including already installed pipes and gas lines.
Pipe attachments	Bend restrictors, clamps, etc., and attachment methods.
Load cases	Definition of yearly probability for installation, normal and abnormal operation. Specification of accidental load cases and yearly probabilities.

### 4.6.3 Dynamic pipe parameters

The purchaser shall specify to the manufacturer the purchaser's requirements for design and analysis of the dynamic pipe, or dynamic jumper system additional to the requirements of Clause 5. The parameters listed in Table 4 should be considered.

**Table 4 — Dynamic pipe parameters**

Parameter	Details
Pipe configuration	Specification of any requirements for the configuration, including description (lazy-S, steep wave, etc.), layout and components; selection of configuration or confirmation of suitability of specified configuration.
Operations	Specification of reeling/unreeling requirements.
Connection systems	Descriptions of upper and lower connection systems, including quick disconnection systems and buoy disconnection systems, connection angles and location tolerances.
Guides and supports	Proposed geometry of guides and tanker rails over which the pipe is to be deployed.
Pipe attachments	Bend stiffeners, buoys, lifting & towing apparatus, clamps etc., and attachment methods.
Attached vessel data	Data for attached floating vessels, including the following: <ul style="list-style-type: none"> <li>a) vessel data, dimensions, drafts, etc.;</li> <li>b) static offsets;</li> <li>c) first (RAOs) and second order motions;</li> <li>d) vessel motion phase data;</li> <li>e) vessel motion reference point;</li> <li>f) mooring system interface data;</li> <li>g) position tolerances.</li> </ul>
Interference requirements	Specification of possible interference areas, including other risers, mooring lines, platform columns, vessel pontoons, tanker keel, etc., and definition of allowable interference/clashing.
Load cases	Definition of yearly probability for installation, normal and abnormal operation. Specification of accidental load cases and yearly probabilities.

## 5 Design requirements

### 5.1 Loads and load effects

#### 5.1.1 General

The pipe design is based on the information supplied by the purchaser (see guidelines of Annex A), with reference to the requirements of Clause 4. All relevant information shall be defined in the design premise (see 8.2) including design load cases. Results of the design load case analyses shall be included in the design load report (see 8.3).

#### 5.1.2 Definition of load classes

**5.1.2.1** As listed in Table 5, loads are classified as functional, environmental (external) or accidental, defined as follows.

NOTE Load classes and many subclasses are listed in the left column of Table 5.

- a) Functional loads are all loads on the pipe in operation, including all loads which act on the pipe in still water, except wind, wave or current loads.
- b) Environmental loads are loads induced by external environmental parameters.
- c) Accidental loads are loads caused by accidental occurrences.

**5.1.2.2** The design load cases shall be defined to analyze, as applicable, the effect on the flexible pipe of functional, environmental and accidental loads. Reference API RP 17B for guidelines on the analysis techniques to be used for the loads given in Table 5.

**Table 5 — Combinations of load classes and load conditions**

Load conditions Load classes and subclasses	Normal operation		Abnormal operation
	Recurrent operation	Extreme operation	
<b>Functional loads</b>			
a) Loads due to weight and buoyancy of pipe, contents and attachments, both temporary and permanent	X	X	X
b) Internal pressure as specified in 4.4.2	Max. operating pressure	Design pressure	Design pressure
c) Pressure and thermal expansion and contraction loads	X	X	X
d) External pressure	X	X	X
e) External soil or rock reaction forces for trenched, buried or rock dumped pipes	X	X	X
f) Static reaction and deformation loads from supports and protection structures	X	X	X
g) Temporary installation or recovery loads, including applied tension and crushing loads, impact loads and guidance induced loads	X	X	X
h) Residual installation loads, which remain as permanent loads in the pipe structure during service	X	X	X
i) Loads and displacement due to pressure and tension-induced rotation	X	X	X
j) Testing pressures, including installation, commissioning and maintenance pressures	X	X	X
k) Interaction effects of bundled or clamped pipes	X	X	X
l) Loads due to rigid or flexible pipe crossings or spans	X	X	X
m) Loads due to positioning tolerances during installation	X	X	X
n) Loads from inspection and maintenance tools	X	X	X
o) Rapid gas decompression	—	—	—
<b>Environmental loads</b>			
a) Loads caused directly or indirectly by all environmental parameters specified in Table 2	100 year conditions	Conditions to meet $P_c = 10^{-2}$	Survival conditions
<b>Accidental loads</b>			
a) Loads and motions caused directly or indirectly by accidental occurrences, including the following:	Not applicable	See <sup>a</sup>	See <sup>b</sup>
1) dropped objects;	"	"	"
2) trawl board impact;	"	"	"
3) internal over-pressure;	"	"	"
4) compartment damage or unintended flooding;	"	"	"
5) failure of thrusters;	"	"	"
6) DP failure;	"	"	"
7) anchor line failure;	"	"	"
8) failure of turret drive system.	"	"	"
<sup>a</sup> Load combinations of the above tabulated functional, environmental and accidental loads, as shown in Table 6, shall be analyzed when the yearly combined probability, $P_c$ , of occurrence is equal to or greater than $10^{-2}$ . <sup>b</sup> Load combinations, as shown in Table 6, of the above tabulated functional, environmental and accidental loads, shall be analyzed when the yearly combined probability, $P_c$ , of occurrence is between $10^{-2}$ and $10^{-4}$ .			

**5.1.3 Load combinations and conditions**

**5.1.3.1** The flexible pipe design shall be shown to meet the design requirements under the load combinations specified in this subclause. All loads, including loads specified in Table 5, which act on the flexible pipe shall be evaluated. Variation of the loads in time and space, load effects from the flexible pipe system and its supports, as well as environmental and soil conditions, shall be analyzed.

**5.1.3.2** The design load conditions that shall be analyzed are installation, normal operation (recurrent and extreme), abnormal operation and factory acceptance testing. Load combinations shall be as defined in the notes for Table 5 and the column headings in Table 6. Load combinations with a yearly probability of occurrence less than  $10^{-4}$  can be ignored. Factory acceptance test (FAT) load combinations shall be defined by the manufacturer based on the FAT procedures.

**5.1.3.3** Design checks shall be carried out for any temporary conditions specified by the purchaser or the manufacturer. These shall be subject to the same design criteria as the design load conditions, as specified in Table 6.

**5.1.3.4** The occurrence probabilities for each load in each load combination shall be defined in the design premise (see 8.2), e.g. for combined wave and current load case the probabilities of each are to be defined. The probability of specific load classes or subclasses may be specified by the purchaser based on project-specific conditions. The probabilities of accidental and installation-related events should be specified by the purchaser (Tables 3 and 4). If the purchaser does not specify probabilities, the manufacturer shall propose the probabilities that are used for the individual events in the design premise.

**5.1.3.5** The design load cases to be analyzed shall be derived from the loading conditions specified in 5.1.2.1 and the column headings in Table 6.

**Table 6 — Flexible pipe layer design criteria**

Flexible pipe layer	Design criteria	Design load cases and combinations					FAT
		Service conditions			Installation		
		Normal operation		Abnormal operation	Functional and environmental	Functional, environmental and accidental	
		Recurrent operation	Extreme operation				
Functional and environmental	Functional, environmental and accidental	Functional, environmental and accidental	Functional and environmental	Functional, environmental and accidental			
Elastomer layers	Strain of aged material	The maximum allowable strain shall be 50 % of design maximum strain for aged material.					
Internal carcass <sup>a</sup>	Stress and buckling load <sup>b</sup>	$(0,67)$ for $D_{max} \leq 300$ m $\{[(D_{max} - 300)/600] \times 0,18 + 0,67\}$ for $300$ m $< D_{max} < 900$ m $(0,85)$ for $D_{max} \geq 900$ m					
Reinforcement layers	Load <sup>c</sup>	0,55	0,85	0,85	0,67	0,85	0,91
<sup>a</sup> For mechanical loads the permissible utilization of the internal carcass shall be as specified for the tensile and pressure reinforcement. <sup>b</sup> $D_{max}$ is the maximum water depth, including tidal and wave effects. <sup>c</sup> The definition of permissible utilization is provided in 5.3.1.4.							

## 5.1.4 Design load effects

In the pipe design, the manufacturer may account for the effects of differential pressures. If the external hydrostatic pressure is included in the calculation of the design internal pressure for the pipe, then the manufacturer shall specify the water depth at which the design internal pressure is given. This shall also be specified in the pipe markings (see 10.1).

Hydrodynamic load effects shall be determined by validated and documented methods that account for the kinematics of the seawater and the interaction effects of the different environmental phenomena. See API RP 17B for guidelines on analysis methods.

For fatigue analysis, the distribution of loads over the service life of the pipe shall be based on methods that include all load parameters. Simplified methods are acceptable if the resulting load distribution can be shown to be conservative.

Any accidental loads or combinations thereof can damage or render unfit for service a flexible pipe. Load cases that include accidental loads (e.g. increased offsets due to anchor-line or thruster failures) and do not violate the requirements of Table 6, define a limit on the safe occurrence of the accidental loads. Some accidental loads (e.g. fire and explosion) might not be easily analyzed in terms of the requirements in Table 6. In such cases, testing shall be used to define safe working times or other limits associated with the accidental load.

## 5.2 Pipe design methodology

**5.2.1** Initially and whenever revisions occur, the pipe-design methodology shall be verified by an independent verification agent. The documentation submitted for verification of the design methodology shall include the following as a minimum:

- a) description of theoretical basis, including calculation procedures for the pipe design parameters required for the design report, as specified in 8.4;
- b) calculation method for all major load-bearing layers and components, for interaction between metallic and elastomer components, and for load sharing and transfer between different layers and components, in particular at and adjacent to the end fitting;
- c) verification of theoretical basis with prototype tests. The verification shall include the capacity of all pipe structural layers. Simplified conservative analysis methods for checking of non-critical layers, such as breaker layers, are acceptable if the method does not influence the reliability of the calculation of loads in the other layers;
- d) documented basis for stress concentration factors used for the steel cable materials, including stress concentrations at and within the end fitting interface, at clamped accessories, and due to contact with rigid surfaces and manufacturing tolerances;
- e) manufacturing and design tolerances, manufacturing-induced loads, welds and other effects, such as shear transfer “knock down” factors on elastomers and bonds, which influence structural capacity;
- f) documentation of the service life methodology, subject to the requirements of 5.3.4.
- g) documentation of the methodologies for evaluating combined load cases (as specified in 5.1.3), including such considerations as simultaneous pressure and bending.

**5.2.2** The independent verification agent shall review and evaluate the design methodology to establish the range of applications for which it is suitable. The independent verification agent shall issue a certificate and a report describing the limits and constraints of the design methodology. The certificate shall be included by the manufacturer in the design report (see 8.4) and the design methodology report shall be available for review by the purchaser.

**5.2.3** The design methodology shall account for the effects of wear, corrosion, manufacturing processes, dimensional changes, creep and aging (due to mechanical, chemical and thermal degradation) in all layers, unless it has been documented that the pipe design does not suffer from such effects.

**5.2.4** It shall be shown that variations in dimensions within manufacturing tolerances do not change utilization values by more than 3 % above the values specified in Table 6.

**5.2.5** The calculation of the thickness for all metallic layers shall include allowances for wear between the strands of individual cables.

**5.2.6** If the pipe design is outside the envelope of previously validated designs, then the manufacturer shall perform a sufficient number of prototype tests to verify the design methodology for this new design. The prototype tests shall verify correlation with the design methodology and fitness-for-purpose for those design parameters which are outside the previously validated envelope. Qualification testing programme and clear acceptance criteria to be agreed upon between manufacturer and purchaser. See API RP 17B for guidelines on the tests which should be performed and recommendations on the test procedures.

**5.2.7** If the pipe is designed to be collapsible, then it shall be shown by the testing that the design criteria are not violated for the specified number of collapse occurrences. The correlation between the test and the design methodology for this calculation shall be documented and verified.

**5.2.8** The methodology shall account for load, stress and strain in the pipe layers and at the end fitting, fatigue of the pipe components and the potential for voids to be generated in the pipe wall. The methodology shall be based on the results of prototype tests.

### **5.3 Pipe structure design**

#### **5.3.1 Design criteria**

**5.3.1.1** The pipe layers shall be designed to the criteria specified in Table 6, subject to the requirements of this subclause.

**5.3.1.2** The utilization for the elastomer layers shall be calculated based on the maximum allowable strain of the elastomer material, subject to the requirements of 5.3.1.1. The methodology shall define the assumed extent of each layer.

**5.3.1.3** The utilization for the internal carcass shall be calculated as specified in 5.3.2.3, taking account of tension effects and the three water-depth ranges defined in Table 6. The manufacturer shall evaluate buckling failure modes in the carcass, and shall confirm by analysis that the layer meets the design requirements. The methodologies for separate and combined tension-induced and hydrostatic collapse calculations of the carcass shall be documented.

**5.3.1.4** The utilization for cables of reinforcing layers shall be calculated as

utilization equals load divided by structural capacity;

if load is the calculated load in the actual layer. The load shall be calculated using the design methodology specified in 5.2, subject to the design requirements of 5.3.2. The calculated value shall include dynamic loads and be based on average stress in the layer. The average load is to be calculated based on distributing the total layer load uniformly over all wires in the layer. The structural capacity shall be either the yield strength of the solid wire or stranded cable material sample, or 0,9 times the ultimate tensile strength of the solid wire or stranded cable material sample where tensile testing will accurately identify only this latter property. The yield or ultimate strength value used for design shall be either the mean value minus two standard deviations from the documented test data, or the minimum value as certified by the supplier.

**5.3.1.5** The utilization for the cover shall be calculated based on the maximum allowable strain, subject to the requirements of 5.3.2.2.

**5.3.1.6** The storage MBR shall be calculated as the minimum bend radius that satisfies all the requirements of Table 6. The bend radius required to cause locking in the interlocked layers shall be calculated. The storage MBR shall be at least 1,1 times the MBR to cause locking.

**5.3.1.7** The operating MBR for static applications (all loading conditions) shall be a minimum of 1,0 times the storage MBR, and for dynamic applications (all loading conditions) shall be a minimum of 1,5 times the storage MBR. For dynamic applications, the safety factor on operating MBR may be reduced from 1,5 to 1,25 for abnormal operation and normal operation with accidental loads.

**5.3.1.8** Metallic fatigue life calculations shall be performed in accordance with the requirements of 5.3.4. The predicted fatigue life shall be at least 10 times the service life. Corrosion analysis (as specified in 5.3.4) shall show that the material loss from corrosion does not cause utilization factors to exceed the criteria of 5.3 under all load combinations.

**5.3.1.9** Reliability-based design may be applied as an alternative design method. All relevant design criteria for the reliability-based design cases should then be considered. It shall be proven that the level of safety obtained is not less than that given by this part of ISO 13628 for comparable design cases.

## **5.3.2 Design requirements for pipe layers**

### **5.3.2.1 Liner**

**5.3.2.1.1** As a minimum, the liner shall be analyzed for the following load cases:

- a) most critical combination of internal pressure, temperature, operating MBR and elastomer condition;
- b) hydrotest pressure at ambient temperature and storage MBR.

**5.3.2.1.2** The analysis should include relevant cyclic loading effects such as hysteresis, relaxation, shrinkage, loss of plasticizer, and diffusion and absorption of fluids into the elastomer matrix. As a minimum, the following shall be included:

- a) pressure and temperature from the fluids inside the pipe;
- b) contact pressure from the carcass;
- c) strain due to pipe bending, axial elongation and compression, torsion and radial expansion.

**5.3.2.1.3** The methodology used for calculating the wall thickness of the liner shall be validated by documented tests and/or field experience, and shall comply with the following minimum requirements.

- a) The analysis shall account for thinning and wear of the elastomer layer due to bending to the operating MBR (storage MBR for hydrotest), stress concentrations due to thickness variations, effect of deplasticization, swelling and aging on material properties, manufacturing tolerances and termination of the layer in the end fitting.
- b) The analysis shall verify the minimum level of coverage the liner provides the reinforcing layer to account for the potential for the liner to extrude between the reinforcing layer cables under design loads.

### **5.3.2.2 Cover**

**5.3.2.2.1** The design of the cover shall account for the effect of pipe bending, axial elongation and compression, torque loads, external pressure, installation loads, abrasion and local loads from ancillary components.



### 5.3.2.3 Internal carcass

5.3.2.3.1 The design of the internal carcass shall account for the following.

- a) Collapse with minimum specified internal pressure, maximum external pressure and maximum ovality. The external pressure shall be the full external pressure acting on outside of cover.
- b) Crack growth along the carcass strip due to bending-induced stresses in interlocked spirals. The carcass design shall be such that crack growth shall not occur.
- c) Loads induced by thermal expansion and contraction and/or swelling of the liner.
- d) Erosion, erosion/corrosion and wear.
- e) Corrosion, including stress corrosion cracking.
- f) Radial compression induced by tension in the axial reinforcement layers.
- g) Collapse with maximum gas absorption in elastomer layer, minimum internal pressure and maximum ovality at occurring temperature.

### 5.3.2.4 Reinforcing layers

5.3.2.4.1 The metallic materials of the reinforcing layers shall be designed for the required axial and hoop strength. The design shall account for any requirements for torsional properties and control of gaps between cables.

5.3.2.4.2 The complete pipe structure shall be designed such that the torsional balance and compression strength characteristics of the pipe meet the functional requirements.

### 5.3.2.5 Additional layers

5.3.2.5.1 Thermal insulation layers shall be designed in accordance with the requirements of 5.4.3.

5.3.2.5.2 Breaker layers shall be demonstrated not to contribute to delamination of elastomer layers in their immediate vicinity following the test specified in 6.2.3.2.

5.3.2.5.3 Additional external protection layers, whether elastomer or metallic, shall be designed to prevent external damage or wear occurring in the cover, based on the design conditions specified by the purchaser.

### 5.3.3 End fitting

5.3.3.1 The end fittings shall be designed for reliable termination of all pipe layers, such that leakage, structural deformation, or pull-out of cables or bonded layers does not occur for the service life of the pipe, taking account of all relevant factors including shrinkage, creep, aging, pressure effects, swelling and temperature. The design methodology for end fittings shall be documented and shall be verified by documented tests and analyses. The methodology shall account for manufacturing tolerances. The design shall account for support loads from any ancillary components attached to the end fitting. The thickness of weld overlay material may be included as part of the wall thickness in end fitting analysis. This requires that the overlay weld material strength is documented to be equal to or higher than the specified end fitting base material strength.

5.3.3.2 The design of the end fitting shall ensure sealing of both the liner and the cover at the end fitting. The design of the end fitting sealing mechanism shall ensure that the combined strain induced by the in-service pull-out forces and installation of the end fitting seal ring does not result in failure of the layer over the service life.

**5.3.3.3** In the design of the end fitting, axial movements of the carcass relative to the end fitting shall be mechanically restrained.

**5.3.3.4** Accounting for all physically possible load combinations, the following design requirements shall apply for the pressure-containing parts of the end fittings:

$$\sigma_t \leq n \times \sigma_y$$

$$\sigma_e \leq n \times \sigma_y$$

where

$\sigma_t$  is the tensile hoop stress;

$\sigma_e$  is the equivalent stress (Von Mises or Tresca);

$n$  is the permissible utilization factor, as specified in Table 7.

**5.3.3.5** For dynamic applications, fatigue life calculations shall be performed in accordance with the requirements of 5.3.4. The predicted fatigue life of the end fitting shall be at least 10 times the service life.

**5.3.3.6** Selection of end fitting materials shall be in accordance with the requirements of Clause 6.

**Table 7 — End fitting permissible utilization factors**

Flexible pipe layer	Design criteria	Design load cases and combinations					
		Service conditions			Installation		FAT
		Normal operation		Abnormal operation			
		Recurrent operation	Extreme operation				
Functional and environmental	Functional, environmental and accidental	Functional, environmental and accidental	Functional and environmental	Functional, environmental and accidental			
End fitting	Permissible utilization	0,55	0,85	0,85	0,67	0,85	0,91

**5.3.4 Service life analysis**

**5.3.4.1 Service life – Static applications**

**5.3.4.1.1** The service life analysis of flexible pipes for static applications shall document the properties of the pipe materials for the specified service life, in accordance with the requirements of Clause 6. The minimum strength for metallic materials and minimum elongation at break for elastomer materials, during the service life of the pipe, shall be used in the design calculations. The analysis shall include as a minimum the following:

- a) creep, dimensional changes (shrinkage, swelling) and strain to failure in the operating environment;
- b) corrosion and erosion of steel components.

**5.3.4.1.2** Service life for sweet service applications shall be determined as follows, subject to the requirements of 5.3.1.

- a) Service life calculated as the length of service that would cause the degradation of elastomer layers to reach the limiting criteria for use. Criteria to be specified by the manufacturer.
- b) Service life calculated as the length of service that would cause localized and general wear of reinforcing layer cables to where the reduction in cross-section results in an increase in the utilization factor to 0,85.

**5.3.4.1.3** Service life for sour-service applications shall be determined as follows, subject to the requirements of 5.3.1:

- a) assessment of service life in accordance with 5.3.4.1.2;
- b) the design shall also document compliance with the requirements of 6.2.4.2.

### **5.3.4.2 Service life — Dynamic applications**

**5.3.4.2.1** For dynamic applications the requirements of 5.3.4.3 shall apply. In addition, a fatigue analysis shall be performed for the cables of the reinforcing layers, which shall take account of all mechanical and dynamic effects that may introduce failure modes into the pipe in the dynamic application. As a minimum, the effects of fatigue, fretting and material degradation shall be accounted for.

**5.3.4.2.2** Dynamic applications shall be evaluated in accordance with the requirements of 5.3.4.2.5 if the H<sub>2</sub>S content exceeds NACE requirements for sour service. Otherwise, the application shall be evaluated in accordance with the requirements of 5.3.4.2.4.

**5.3.4.2.3** Steel components of reinforcing layers for use in flexible pipes can be sensitive in fatigue to low levels of H<sub>2</sub>S, and thus for dynamic service, the effect of H<sub>2</sub>S shall be evaluated.

**5.3.4.2.4** Service life for sweet-service applications shall be determined as follows, subject to the requirements of 5.3.1:

- a) in accordance with assessment for static applications under 5.3.4.1.2;
- b) assessment of service life for cables of reinforcing layers based on data from 6.2.4.4.

**5.3.4.2.5** Service life for sour-service applications shall be determined as follows, subject to the requirements of 5.3.1:

- a) assessment shall be in accordance with 5.3.4.2.4 for sweet service based on data from 6.2.4.4 a);
- b) a verified model shall be required to assess the H<sub>2</sub>S and CO<sub>2</sub> partial pressures at the surface of the cables of reinforcing layers.

### **5.3.4.3 Fatigue analysis**

For dynamic applications the analysis of load conditions shall show that the extreme stresses in the cables of the reinforcing layers are below the endurance limit. Otherwise, fatigue damage calculations should be performed. Fatigue damage calculations shall be based on Miner's method using design S-N curves, which have been validated for the reinforcing materials used, under the applicable service environment that shall include likely corrosive conditions. The fatigue life analysis shall also confirm that the liner and cover maintain integrity under the calculated alternating strains in the applicable service environment. The fatigue life shall be at least 10 times the specified service life.

## 5.4 System design requirements

### 5.4.1 General

**5.4.1.1** The design of the flexible pipe should account for all system requirements specified in 4.6, as listed in Table 8, and in accordance with the additional requirements specified in 5.4.2 to 5.4.6. The design shall be documented to meet all interface requirements specified by the purchaser or by the manufacturer.

**Table 8 — System-related pipe design requirements**

General requirements	Flowline requirements	Riser requirements	Loading and discharge hose requirements
Corrosion protection	Flowline routing	Riser configuration	Hose installation
Thermal insulation	Guides and supports	Connection systems	Hose configuration
Gas venting	Protection requirements	Pipe attachments	Connection systems
Pigging and TFL requirements	On-bottom stability	Vessel data	Guides and supports
Fire resistance	Upheaval buckling	Interference requirements	Vessel data
Piggyback lines	Crossover requirements	Design load cases	Pipe attachments
Connectors	Pipe attachments		Operation procedures
Interface definitions	Design load cases		Design load cases
Inspection and condition monitoring			
Installation requirements			
Exothermal chemical reaction cleaning			
Gas absorption and rapid gas decompression (RGD)			

**5.4.1.2** If applicable, the effect of trenching, burying or dumping pipes shall be checked for upheaval buckling, upheaval creep and termination load capacity resulting from pressure and temperature-induced axial elongation. The effect of pipe bending stiffness variations, due to time, temperature and pressure, on the pipe loads should be analysed.

**5.4.1.3** For dynamic riser applications, interference/clashing with other components of the system, including risers, mooring lines, and rigid surfaces such as pontoons, shall be checked in the design.

**5.4.1.4** If applicable, the elastomer/steel friction coefficient for the cover material shall be documented for design of the pipe for installation tensioner compression forces, and for design of devices to be clamped to the pipe.

**5.4.1.5** The lateral and longitudinal elastomer/soil friction coefficients shall be documented for the cover for on-bottom stability design.

### 5.4.2 Corrosion protection

#### 5.4.2.1 Galvanic corrosion

Selection of materials shall consider the effect of galvanic corrosion, where this could increase utilization factors above allowable limits. Where there is the possibility of galvanic corrosion occurring, dissimilar metals shall be isolated from one another with insulation, a coating or a sufficient corrosion allowance.

#### 5.4.2.2 Surface treatment

All external steel surfaces shall be prepared and coated in accordance with internationally recognized standards for corrosion protection in all environmental conditions specified in Clause 4, unless the material is documented to be corrosion-resistant in the specified environment.

#### 5.4.2.3 Corrosion allowance

**5.4.2.3.1** Requirements for internal and external corrosion allowances shall be evaluated in accordance with the location, conditions of installation and the requirements specified in Clause 4. The manufacturer shall document this evaluation and its effect on the pipe components.

**5.4.2.3.2** Corrosion in the carcass or cables of the reinforcing layers at the end-fitting interface shall not cause damage to any sealing barrier or locking mechanism.

**5.4.2.3.3** Corrosion-resistant overlay or corrosion-resistant alloys may be used in preference to a corrosion allowance. The manufacturer shall have documented records on the suitability of the corrosion-resistant overlay or alloys for the specified application and environment.

#### 5.4.2.4 Cathodic protection

Design of cathodic protection systems shall be in accordance with the requirements of 4.6.1.3. The design of cathodic protection systems by means of anodes electrically connected to a pipe end fitting, requires electrical continuity between cables of the reinforcing layers and end fitting. The cathodic protection system design methodology shall be documented. See DNV RP B401 for guidelines on the design of cathodic protection systems. Cathodic protection systems shall be designed to facilitate any requirements for electrical isolation of offloading and discharge pipes from support structures.

#### 5.4.3 Thermal insulation

**5.4.3.1** The materials used for thermal insulation layers shall be selected such that the overall heat transfer coefficient does not degrade to a level below the value specified in 4.6.1.4 for the specified service life.

**5.4.3.2** Conditions experienced during storage, transportation, handling, installation and operation shall be analysed. The analysis shall document that permanent deformation of the insulation layers, due to crushing caused by items including tensioners, reels, sheaves, rollers, self weight and impact loads, does not change the heat transfer coefficient beyond the specified requirements.

#### 5.4.4 Gas venting

**5.4.4.1** The gas-venting system shall be designed in accordance with the requirements of 4.6.1.5 and the following:

- a) safe removal of accumulated fluid components;
- b) no uncontrolled pressure build-up outside the pipe if the pipe is located within an enclosed space;
- c) chemical resistance of all parts exposed to the permeated gas;
- d) For flexible subsea lines with annulus venting in air or connected to a platform annulus gas vent system, no vent ports to be made in the pipe section other end subsea end fitting, with the exception of jumpers connected to mid-water arches or riser towers;
- e) As a minimum, three working vent ports equally spaced 120° around the circumference per end fitting shall be required.

**5.4.4.2** The design of all layers in the pipe shall allow for permeated gas to be vented.

#### 5.4.5 Pigging and TFL operations

**5.4.5.1** The flexible pipe shall be designed for the pigging, TFL, workover and other tool requirements specified in 4.6.1.6. The selection of dimensional tolerances, including ovality, shall be in accordance with the specified requirements. See ISO 13628-3 for guidelines on TFL systems.

NOTE For the purposes of this provision, API RP 17C<sup>[4]</sup> is equivalent to ISO 13628-3.

**5.4.5.2** The innermost layer (carcass or liner) selected for the pipe design shall be compatible with the specified requirements, and the manufacturer shall have performed documented tests to demonstrate compatibility.

**5.4.5.3** The pipe design should result in a smooth interface between the innermost layer and the end fitting. Any variation, steep or constant, in wall thickness due to corrosion shall not influence pigging operations. End-fitting designs shall be such that a variation in wall thickness as a result of corrosion shall not result in damage to the internal carcass or liner during pigging operations.

#### 5.4.6 Fire resistance

**5.4.6.1** Fire resistance of flexible pipes is measured by testing the time a pipe and/or end fittings can be exposed to fire without loss of pressure. Fire-protective insulation may be applied to flexible pipe bodies and end fittings to slow the degradation due to heat. However, the pipes cannot be rendered fire-proof. Flexible pipes exposed to fire shall be considered unfit for further service until detailed examination can demonstrate otherwise.

**5.4.6.2** Fire-resistance requirements specified by the purchaser should consider the following:

- a) fire temperature, source and surrounding material;
- b) need to extinguish or cool the pipe structure;
- c) fire extinction method;
- d) time required to extinguish;
- e) transported medium;
- f) heated steel in contact with elastomeric material in the flexible pipe;
- g) pipe abandonment facility and its fire protection capability;
- h) pipe function;
- i) flash point of transported medium in the event of a leak;
- j) depressurization time.

**5.4.6.3** If fire resistance is required in accordance with 4.6.1.7, the pipe shall be tested in accordance with Lloyd's or DNV Fire Test, unless previous testing of the design has been performed and documented.

## 6 Materials

### 6.1 Material requirements

#### 6.1.1 General

**6.1.1.1** The requirements of 6.1 shall apply to elastomer materials including additives, flat metal strips for carcasses, textiles and fabrics, as used in breaker layers, cables, and finished or semi-finished end-fitting components, as delivered to the pipe manufacturer by suppliers. Subclause 6.1 does not cover the use of composite materials for structural layers.

**6.1.1.2** The manufacturer shall have on file, records of tests demonstrating that the materials selected for a specific application meet the functional requirements specified in Clause 4 for the service life, for both operation and installation conditions. The documented test records shall conform to the requirements of 6.2 below. If suitable qualification records do not exist, the manufacturer should conduct testing relevant to the application according to 6.2.

**6.1.1.3** All materials including material for breaker layers and other manufacturing aids used in the flexible pipe construction shall be documented to be compatible with permeated gases and liquids at design temperatures. All materials exposed to seawater shall be documented to be compatible with seawater. The manufacturer shall document that all corrosion protection coatings used in the manufacture of the pipe are compatible with all other structural or pressure-sealing materials in the pipe.

#### 6.1.2 Elastomer materials

##### 6.1.2.1 General

**6.1.2.1.1** The manufacturer shall utilize documented design standards, based on tests as specified in Table 9, that define the pre-qualified range and combination of exposure conditions for each of the vulcanized elastomers used in the liner, embedding compound, insulation layer and cover.

**6.1.2.1.2** The validity of an elastomer qualification applies only for the specific compound with its constituents. Any substitutions or change of major constituents or suppliers of those requires a re-qualification of the compound.

##### 6.1.2.2 Liner

**6.1.2.2.1** The manufacturer shall document the mechanical, thermal, fluid compatibility and permeability properties of the material for the liner, as specified in Table 9, for a range of temperatures and pressures that shall include the design values.

**6.1.2.2.2** The manufacturer shall have documented methods for predicting the elastomer properties for the specified service life. The manufacturer shall have available for review by the purchaser records of tests and evaluations, which demonstrate that the methods yield conservative results.

**6.1.2.2.3** If the conveyed fluid contains gas, the elastomer shall be shown, by testing, to not blister or degrade during rapid depressurization from the maximum pressure and temperature conditions. Refer to 6.2.3.2, which specifies a decompression rate etc. The effect of aging and swelling on permeability shall be analysed. Manufacturer shall specify the criteria to be applied to the elastomer for assessment of serviceability (embrittlement, creep, shrinkage, swelling, plastic deformation, etc.) and quantify its application, using results of testing in accordance with 6.1.2.2.2.

**6.1.2.2.4** The RGD testing shall take account of permeation rate and sample size to ensure saturation before the first cycle. It should be shown by diffusion calculations that at least 90 % saturation of the liner material is reached before the first decompression cycle. A holding period to ensure saturation shall be calculated.

Chemicals that affect the elastomer shall be included in the RGD testing of relevant properties according to service conditions. This shall be accomplished by aging the specimens in fluids (see 6.2.3.4) that include the chemicals before performing RGD testing.

**Table 9 — Property requirements tests for elastomer materials**

Characteristic	Tests <sup>b</sup>	Liner	Embedding compound <sup>e</sup>	Cover	Insulation layer <sup>a</sup>
Mechanical/ physical properties	Tensile strength/elongation	X	X	X	X
	Stress relaxation properties	X	—	X	—
	Hardness	X	X	X	—
	Compression set	X	X	X	X
	Hydrostatic pressure resistance	—	—	—	X
	Abrasion resistance <sup>d</sup>	X	—	—	—
	Tearing resistance	X	X	X	—
	Void formation	X	X	X	—
	Adhesion	X	X	X	X
	Density	X	X	X	X
Thermal properties	Coefficient of thermal conductivity	X	X	X	X
	Brittleness (or glass transition) temperature	X	X	X	
Permeation characteristics	Fluid permeability	X	X	X	X
	Blistering resistance <sup>c</sup>	X	—	—	—
Compatibility and aging	Fluid compatibility	X	X	X	X
	Aging	X	X	X	—
	Ozone resistance	—	—	X	—
	Swelling	X	—	X	—
	Water absorption	X	—	X	X

NOTE There are no property requirements for manufacturing aid materials.

<sup>a</sup> The property requirements specified for the insulation layer apply to the use of both elastomers and non-elastomers.

<sup>b</sup> Test procedures are specified in Table 11.

<sup>c</sup> The requirement for blistering resistance tests applies only to pipes intended for live crude and gas service.

<sup>d</sup> The abrasion resistance test is intended for pipes without an internal stripwound carcass.

<sup>e</sup> The requirements for the embedding compound shall also cover the elastomer in breaker layers.

### 6.1.2.3 Breaker layers

The manufacturer shall document the properties specified in Table 9 for the elastomer material of the breaker layer.

### 6.1.2.4 Reinforcing layer

The manufacturer shall document the properties specified in Table 9 for elastomer material in the reinforcing layer (embedding compound).



### 6.1.2.5 Cover

**6.1.2.5.1** The manufacturer shall document the properties specified in Table 9 for the cover material.

**6.1.2.5.2** A documented evaluation shall be performed by the manufacturer, to confirm compatibility of the cover with all permeated fluids, ancillary components and all external environmental conditions specified in 4.5.

### 6.1.2.6 Insulation layer

**6.1.2.6.1** For the insulation layer material, the manufacturer shall document the relevant properties specified in Table 9. The thermal conductivity of the layer shall be documented for the design and operating temperatures and pressures. Degradation of thermal performance over the specified service life, due to pressure, temperature, permeated gas and seawater where applicable, shall be analysed. Creep in the insulation material shall not result in loss of thermal insulation, such that the overall thermal insulation of the pipe is less than the design requirements.

**6.1.2.6.2** The manufacturer shall document and verify with tests, that the compressive strength of the insulation material is sufficient to withstand all expected compressive loads, within the design requirements of 5.4.3.

**6.1.2.6.3** ASTM C335 may be used to test the overall heat transfer properties of the insulation layer.

### 6.1.3 Metallic materials

#### 6.1.3.1 General

Metallic material selection shall consider corrosive attack appropriate to the environment that the layer will be exposed to over the specified service life of the pipe. Materials for sour service applications shall be tested in accordance with 6.2.4.2. All metallic components designed for, or that can be exposed to, cathodic protection shall be made of materials that have documented resistance against hydrogen embrittlement in the applicable environment.

#### 6.1.3.2 Carcass

**6.1.3.2.1** The manufacturer shall document the properties and characteristics specified for the carcass in Table 10. For the specified application, the manufacturer shall evaluate, for each of the listed characteristics, the suitability of the selected carcass material, and shall have available for review by purchaser documented tests to confirm the suitability of the material for the application, together with the criteria for acceptance.

**6.1.3.2.2** If the carcass is to be exposed to tools passing through the pipe, including pigs, TFL and workover equipment, the wear rate from all expected occurrences should be calculated or experimentally determined. Additional sacrificial material shall be included in pipes that are expected to experience high wear or abrasion rates. The amount of additional material should be determined by analysis using wear-rate data and expected occurrence rates.

**6.1.3.2.3** If the conveyed fluid contains entrained solids, the manufacturer should calculate the erosion and erosion/corrosion rates for the specified fluid velocities and content over the service life of the pipe and should document that the calculated wear rates do not cause failure of the carcass.

**6.1.3.2.4** The material selection for the carcass shall account for the installation conditions, in particular if the pipe is to be temporarily filled with seawater.

#### 6.1.3.3 Reinforcing layer

**6.1.3.3.1** The manufacturer shall document the properties and characteristics specified for the cables of the reinforcing layers in Table 10, subject to the requirements of 6.1.3.2.1.

**6.1.3.3.2** For the specified application, the manufacturer shall document the sensitivity to corrosion (uniform and pitting) or cracking (SSC, HIC, and fretting) of the rubberized carbon-steel materials selected for the pressure and tensile cables, and shall have documented test records that confirm the suitability of the material for the particular application.

**Table 10 — Property requirements tests for metallic cables and strip materials and weldments**

Properties/characteristics	Parameter	Carcass	Reinforcing layers
Alloy properties	Chemical composition	X	X
	Microstructure	X	X
Mechanical properties	Yield strength	X	X
	Ultimate strength	X	X
	Elongation	X	X
	Fatigue resistance	—	X
	Erosion resistance	X	—
Material characteristics	SSC and HIC resistance <sup>a</sup>	—	X
	Corrosion resistance	X	X
	Cracking resistance under cathodic protection	—	X
	Chemical resistance	X	X
	Wear resistance <sup>b</sup>	—	X
NOTE Test procedures are specified in Table 12.			
<sup>a</sup> SSC and HIC Resistance tests apply to sour service pipes only, subject to 5.3.4.2.3.			
<sup>b</sup> To be confirmed by inspection of cables in fatigue test pipes. No cable wires shall be worn or broken.			

**6.1.4 End fitting**

**6.1.4.1 Metallic materials**

**6.1.4.1.1** End-fitting metallic components for primary pressure-containing parts shall be wrought or forged in accordance with the requirements of ASTM A668, ASTM A29, ASTM A182 Grade F51 (duplex steel) or the requirements for connectors specified in ISO 10423.

NOTE For the purposes of this provision, API spec 6A<sup>[7]</sup> is equivalent to ISO 10423.

For sour service applications, metallic materials shall conform to the requirements of ISO 15156.

NOTE For the purposes of this provision, NACE MR0175 is equivalent to ISO 15156.

**6.1.4.1.2** The manufacturer shall document the chemical composition, manufacturing method, heat treatment, and the tensile, hardness and Charpy impact properties for the metallic materials in all primary end-fitting components. The chemical composition should be selected to ensure that the components meet the specified properties after all manufacturing processes, including welding and weld heat treatments.

**6.1.4.1.3** The end fitting shall be resistant to corrosion, either by way of material selection or by means of the combination of a suitable coating and cathodic protection. The material for the end fitting internal surfaces shall have documented resistance to erosion due to solids entrained in the conveyed fluid.

**6.1.4.1.4** For applications requiring weld overlay, all surfaces exposed to the conveyed fluid shall be documented by tests to be corrosion-resistant.

#### 6.1.4.2 Epoxy material

**6.1.4.2.1** If epoxy is used, the epoxy filler material used to embed the cables of the reinforcing layers shall be documented to withstand the temperatures experienced by the end fitting, during manufacture and service, for the specified service life. Consideration shall be given to the maximum temperatures that the end fitting experiences in enclosed spaces, such as underneath fire insulation and bend stiffeners.

**6.1.4.2.2** The manufacturer shall document the compressive strength or shear strength of the epoxy at a temperature between 20 °C and 25 °C (68 °F and 77 °F), and at design minimum and maximum temperatures. Glass transition temperature, fluid compatibility and aging characteristics of the epoxy shall be documented. The epoxy used in testing shall be mixed and cured according to the supplier's specifications.

### 6.2 Qualification requirements

#### 6.2.1 General

##### 6.2.1.1 Test requirements

The physical, mechanical, chemical and performance characteristics of all materials in the flexible pipe shall be verified by the manufacturer through a documented qualification programme. The programme shall confirm the adequacy of each material based on test results and analysis that shall demonstrate the documented fitness for purpose of the materials for the specified service life of the flexible pipe. As a minimum, the qualification programme shall include the tests specified in 6.2. The qualification of materials by testing should consider all processes (and their variation) adopted to produce the pipe, which can impair the properties and characteristics required by the design. For any product purchased, documented test results shall be available showing acceptable performance in conditions equal to or more severe than those specified by the purchaser.

##### 6.2.1.2 Test data

Test data shall be kept on file for twenty years after delivery to purchaser, or the service life, whichever is greater.

##### 6.2.1.3 Applicability

**6.2.1.3.1** Only primary component materials with identical specified chemistry and processing history (heat treatment and cold deformation), and from the same supplier as used in the qualification testing or from a supplier who has satisfied the quality assurance requirements of 6.3, shall be regarded as qualified.

**6.2.1.3.2** Documented operational experience may be accepted as verification of long-term properties in environments which are equal to or less severe than the documented experience. The severity of the environment for metallic components shall be determined by temperatures, stresses, contact pressures, corrosive environments, pH, chloride content, injected chemicals, concentrations of H<sub>2</sub>S and CO<sub>2</sub>, and other conditions deemed by the manufacturer or purchaser to be detrimental. The environmental factors considered for elastomers shall include temperatures, stresses, strains, pressures, concentrations of water, aromatics, alcohols, H<sub>2</sub>S and CO<sub>2</sub>, UV exposure, ozone exposure, acidic conditions (lower pH or higher TAN), and other conditions deemed by the manufacturer or purchaser to be detrimental.

##### 6.2.1.4 Test methods

The test methods shall be as specified in 6.2. Where test methods are not specified, the manufacturer may use the manufacturer's own methods/criteria or other ones developed by the raw material supplier. In such cases, the methods and/or criteria shall be documented and the results correlated with the specific material applications. The documented qualification performance shall be verified by an independent verification agent.

-----

6.2.2 Elastomer materials

6.2.2.1 Samples used for qualification testing shall be taken from vulcanized material. Tests shall be performed to determine the properties of unaged material.

6.2.2.2 In the qualification programme, the manufacturer shall test and document the properties specified in Table 9 for the elastomer layers and insulation layer materials. The test procedures specified in Table 11 should be used. If no International Standard test procedure is available, the manufacturer shall document the test procedure.

6.2.2.3 If PVC is used as the insulation material, a heat stability test shall be performed at or above the maximum design temperature for a period of at least 30 days.

Table 11 — Test procedures for elastomer materials

Characteristic	Tests	Test procedure <sup>a</sup>	Comments
Mechanical / physical properties	Tensile strength/elongation	ASTM D638	Or ISO 37.
	Stress relaxation properties	ASTM E328	Swaged end fitting only.
	Hardness	ISO 868 <sup>b</sup> or ASTM D2583	Or DIN 53505.
	Compression set	ASTM D395	Swaged end fittings only.
	Hydrostatic pressure resistance	—	Insulation material only.
	Abrasion resistance	ISO 4649	Or DIN 53516. Not required for liner material used with an internal steel stripwound carcass.
	Tearing resistance	ASTM D624	Or ISO 34-2.
	Void formation	6.2.3.5	—
	Adhesion	ASTM D413 ISO 4647	Or BS/ISO 36. Between elastomer layers. Between cables and elastomer — modified for wire.
Density	ISO 2781	—	
Thermal properties	Coefficient of thermal conductivity	ASTM C177	—
	Brittleness temperature	ASTM D746	Or ISO 812.
Permeation characteristics	Fluid permeability	6.2.3.1	As a minimum to CH <sub>4</sub> , CO <sub>2</sub> , H <sub>2</sub> S and methanol, where present, at design temperature and pressure.
	Blistering resistance	6.2.3.2	At design conditions; gas service pipes only.
Compatibility and aging	Fluid compatibility	6.2.3.3	—
	Aging	6.2.3.4	Refer to ISO 188 for guidelines.
	Ozone resistance	ISO 1431-1	—
	Swelling	ISO 1817	—
	Water absorption	ASTM D570	Insulation material only.

NOTE The test requirements are specified in Table 9.

<sup>a</sup> The test procedures apply to elastomer layer materials and insulation layer materials, both elastomer and non-elastomer.

<sup>b</sup> For the purposes of this provision, ASTM D2240 is equivalent to ISO 868.

## 6.2.3 Elastomer test procedures

### 6.2.3.1 Fluid permeability

**6.2.3.1.1** For fluid permeability tests the following conditions shall apply, as a minimum.

- Sample: Sample shall be taken from a vulcanized elastomer layer.
- Thickness : As a minimum, 1 mm (0.04 in).
- Diameter: As a minimum, 70 mm (2.76 in).
- Temperature: Perform sufficient tests to allow for linear interpolation.
- Pressure: As with temperature.

**6.2.3.1.2** The procedure for the fluid permeability test may be to pressurize one side of the specimen and measure fluid flow at the other side when steady-state flow conditions are reached. Alternatively, the test may be performed with the same absolute pressure on both sides using the partial pressure as the driving force.

**6.2.3.1.3** The fluid permeability test shall also measure the diffusivity and solubility parameters of the elastomer.

### 6.2.3.2 Blistering resistance

**6.2.3.2.1** The requirements of 6.2.3.2 apply to pipes intended for live crude and gas service only.

**6.2.3.2.2** A full-scale prototype test shall be carried out to verify the integrity of the pipe with respect to blistering resistance. See to API RP 17B for guidelines on test procedures.

**6.2.3.2.3** As an alternative, small-scale blistering resistance tests which reflect the design requirements, relating in particular to fluid conditions, pressure, temperature, number of decompressions and decompression rate may be performed. The independent verification agent shall confirm the suitability of the small-scale blistering samples in the design methodology report. A minimum of five samples shall be tested. As a minimum, the following conditions shall apply.

- Fluid mixture: Gas components of specified environment as documented in test procedure with a minimum of 5 % CO<sub>2</sub>.
- Soak time: Sufficient to ensure saturation. First saturation cycle to be a minimum of 72 h depending on the sample dimensions. It should be shown by diffusion calculations that at least 90 % saturation of the liner material is reached before the first decompression cycle.
- Test cycles: If available, use expected number of decompressions or else use 20 cycles as a minimum.
- Decompression rate: If available, use expected decompression rate or else use minimum 7 MPa (70 bar) per minute.
- Thickness: Liner wall thickness, as a minimum.
- Temperature: Expected decompression temperature.
- Pressure: Design pressure, as a minimum.
- Procedure: After tenth and twentieth depressurization cycles, the sample shall be examined at a magnification of  $\times 20$  for signs of blistering, swelling, cracks and slitting.

**6.2.3.2.4** The acceptance criteria shall be that no blister formation, slitting or leakage path is observed. If slitting is observed, the cause shall be determined and shown not to be detrimental to pipe performance. Voids smaller than can be observed at  $\times 1$  magnification are acceptable, as long as the voids are not increasing in size between decompressions.

### **6.2.3.3 Fluid compatibility**

**6.2.3.3.1** The manufacturer shall document the evaluation of all components of the environment to which the elastomer is exposed, and perform tests on those components that are considered to possibly have adverse effects on the elastomer. The criteria for acceptance shall be verified by an independent verification agent.

**6.2.3.3.2** Fluid compatibility tests shall be performed in accordance with the manufacturer's or material supplier's documented procedures. Laboratory tests with vulcanized samples may be used to determine gross incompatibility. Tests shall be based on the design conditions of temperature, pressure and strain. As a minimum, tensile strength, elongation at break, visual appearance, swelling, and fluid absorption (weight gain) and desorption (weight loss) shall be measured/evaluated in the test.

**6.2.3.3.3** For sour-service applications, the effects of  $H_2S$  at the design pressure and temperature shall be evaluated. Additional curing of the elastomers by the  $H_2S$  or other fluid components over the service life of the pipe shall be evaluated based on small-scale material tests. The aged material shall be shown to meet the specified design requirements at the end of the service life.

The effect on the elastomer of sulfur liberated by  $H_2S$  and reacting with steel components shall be evaluated in the test programme.

### **6.2.3.4 Aging**

**6.2.3.4.1** The manufacturer shall have documented aging prediction models for each elastomer in the flexible pipe. The models shall be based on the testing of new and aged materials and experience, and shall predict the aging or deterioration of the elastomer under the influence of environmental and load conditions that have been identified to be relevant through testing. The aging models may include accumulated damage concepts based on blocks of time or operational cycles of temperature/pressure under different exposure conditions. Aging may be determined by either change in specified mechanical properties or in specified physico-chemical characteristics, which includes reduction in the plasticizer content of the material.

**6.2.3.4.2** The fluid used in aging resistance tests should be representative of the specified internal fluid. Materials that are tensile- or compressive-loaded in service should be tested with similar stresses induced.

### **6.2.3.5 Void formation**

**6.2.3.5.1** The manufacturer shall document the evaluation of void formation due to gas permeation and due to the gases generated by the curing process and any gases entrapped by the calendering or winding processes.

**6.2.3.5.2** The acceptance criteria shall be that no visible voids shall form.

## **6.2.4 Metallic materials**

### **6.2.4.1 Test requirements**

The qualification test requirements for carcass and reinforcing layer materials shall be as specified in Table 12.

**Table 12 — Test procedures for metallic materials (carcass strip, reinforcement cables) and weldments**

Tests	Test procedure	Comments
Chemical composition	ASTM A751	Or ISO 16120-1.
Yield strength/elongation	ISO 6892 <sup>b</sup>	—
Ultimate strength/elongation	ISO 6892 <sup>b</sup>	—
SSC and HIC <sup>a</sup>	6.2.4.2	To specified environments; reinforcement armour only.
Erosion resistance	6.2.4.3	Carcass only.
Fatigue resistance	6.2.4.4	Reinforcement armour in dynamic applications only.
Chemical resistance		To specified environments.
NOTE The test requirements are specified in Table 10.		
<sup>a</sup> SSC and HIC resistance tests apply to sour-service pipes only, in accordance with 5.3.4.2.3.		
<sup>b</sup> For the purposes of this provision, ASTM A370 is equivalent to ISO 6892.		

### 6.2.4.2 SSC and HIC testing

**6.2.4.2.1** For sour-service static applications, the threshold limits of the rubberized steel cables in respect to HIC and SSC shall be determined as specified by 6.2.4.2.2 and 6.2.4.2.3, according to manufacturer's documented criteria.

**6.2.4.2.2** To determine the resistance of the rubberized steel cable material to HIC and SSC, the cables shall be submitted to the NACE TM0177 (SSC) tests at a constant pH between 3,5 and 3,8. The threshold level for the occurrence of SSC shall be determined by loading multiple tensile specimens at increasing stress levels which gives a fail/no fail test result from a tensile load test.

**6.2.4.2.3** The manufacturer shall additionally demonstrate through analysis and testing (duration 720 h) the SSC performance at the actual service condition of the rubberized steel cable material. The actual service condition consists of the equivalent partial pressure of H<sub>2</sub>S, CO<sub>2</sub> and CH<sub>4</sub> in the pipe bore, in aqueous solution at ambient temperature, design pressure, and design stress levels. The CH<sub>4</sub> may be replaced with another inert gas.

**6.2.4.2.4** For dynamic applications, the reinforcing layer metallic materials shall be subjected to the qualification testing specified in 6.2.4.4 a), for the specific application. S-N data shall clearly define the endurance limit, if this exists, for the material under the design conditions and shall be documented, or generated, for the conditions in 6.2.4.4 a).

### 6.2.4.3 Erosion resistance

The manufacturer shall demonstrate, either with tests or analytical data based on tests, that the innermost layer has sufficient erosion resistance to meet the design requirements for the specified service life, subject to the requirements of 6.1.3.2.3. Reference API RP 17B for recommendations on erosion tests.

### 6.2.4.4 Fatigue resistance

For dynamic applications, rubberized steel cables (with embedding compound) shall be subjected to the testing given in 6.2.4.4 a) and b), and evaluation, or equivalent documentation provided. The maximum thickness of the rubber coating on the steel cables shall be not greater than the minimum design thickness of the embedding compound in the pipe construction. Reference API RP 17B for recommendations on fatigue testing and interpretation. S-N data shall be documented or generated for the following conditions:

- a) exposed to air, at atmospheric pressure, at a temperature between 12 °C and 23 °C (53.6 °F and 73.4 °F), with wires rubberized, and tested to manufacturer's specifications;
- b) exposed to predicted environment as in 6.2.4.2.3.

## 6.2.5 End fitting

### 6.2.5.1 Metallic materials

**6.2.5.1.1** The combination of temperature variations (maximum and minimum, design temperatures), pressure variations (especially with high gas content), swelling due to gas absorption and liquid absorption and the ability of the end-fitting design to withstand the combined loading shall be documented. The number of cycles shall be realistic with respect to operational conditions. The test fluid should reflect service conditions; reference is made to 4.4.4. The test should be performed according to the methodology specified in API RP 17B, Appendix A or Appendix C as applicable.

**6.2.5.1.2** Test samples used in the qualification of metallic materials for end fitting components shall be in accordance with 6.2.5.1.3 and 6.2.5.1.4. The qualification programme shall test and document the following properties and characteristics of the metallic materials for the primary end fitting components:

- a) chemical composition: ASTM A751;
- b) shear strength;
- c) tensile properties: ISO 6892;

NOTE For the purpose of this provision, ASTM A370 is equivalent to ISO 6892.

- d) Charpy impact: 6.2.5.1.5 and 6.2.5.1.6;
- e) hardness: 6.2.5.1.7;
- f) SSC and HIC resistance: 6.1.4.1.1.

The requirement in 6.2.5.1.2 f) apply to pipes intended for sour service only. If duplex stainless steel end fittings are specified, they shall be tested for pitting resistance in accordance with ASTM G48, Method A.

**6.2.5.1.3** The mechanical properties of forgings shall be determined from test samples that represent the actual component, including being from the same heat and heat treatment batch, and having the same forging ratio. The location of test samples shall represent the heaviest thickness, and shall be taken in  $1/4 t$  position from OD (where  $t$  is the thickness of the component).

**6.2.5.1.4** If end-fitting components of different dimensions are in the same lot, it is sufficient to test the largest dimensions only, provided the strength requirement is the same in all dimensions.

**6.2.5.1.5** Charpy V-notch impact testing shall be carried out in accordance with ISO 6892 for carbon or low-alloy steel forgings. Full-sized Charpy V-notch specimens as defined in ISO 6892 shall be used whenever possible. The notch shall be perpendicular to the surface. The test temperature shall be  $-20\text{ }^{\circ}\text{C}$  ( $-4\text{ }^{\circ}\text{F}$ ) or the design minimum temperature if lower than  $-20\text{ }^{\circ}\text{C}$  ( $-4\text{ }^{\circ}\text{F}$ ). Energy values shall be in accordance with the manufacturer's specifications, which shall specify minimum single energy values and minimum average of three values, acceptable specimen sizes to be  $10\text{ mm} \times 10\text{ mm}$  ( $0.4\text{ in} \times 0.4\text{ in}$ ),  $10\text{ mm} \times 7,5\text{ mm}$  ( $0.4\text{ in} \times 0.3\text{ in}$ ) and  $10\text{ mm} \times 5\text{ mm}$  ( $0.4\text{ in} \times 0.2\text{ in}$ ).

NOTE For the purpose of this provision, ASTM A370 is equivalent to ISO 6892.

**6.2.5.1.6** Impact testing is only required for steel materials with thickness above  $6\text{ mm}$  ( $0.24\text{ in}$ ) and minimum design temperature less than  $0\text{ }^{\circ}\text{C}$  ( $32\text{ }^{\circ}\text{F}$ ) or, if specified, by the purchaser.

**6.2.5.1.7** The hardness tests of carbon steel forgings and corrosion-resistant weld overlays shall be performed in accordance with ISO 6506-1, ISO 6508-1 or ASTM E92. The results shall be to manufacturer's specifications, which shall distinguish between sour and sweet service applications. For sour service, hardness values shall be in accordance with ISO 15156.

NOTE 1 For the purpose of this provision, ASTM E10 is equivalent to ISO 6506-1.



NOTE 2 For the purpose of this provision, ASTM E18 is equivalent to ISO 6508-1.

NOTE 3 For the purpose of this provision, NACE MR0175 is equivalent to ISO 15156.

### 6.2.5.2 Epoxy material

**6.2.5.2.1** Epoxy samples for testing shall be moulded and cured under the same temperature and humidity conditions as when filling the end fitting. The qualification test requirements for the cured epoxy shall be as follows:

- a) compressive strength: ASTM D695 or  
shear strength: 6.2.5.3;
- b) glass transition temperature: ASTM E1356;
- c) fluid compatibility: 6.2.3.3;
- d) aging test: 6.2.3.4;
- e) degree of cure: DSC to ASTM D5028.

### 6.2.5.3 Shear strength test

**6.2.5.3.1** The manufacturer shall have documented procedures for evaluating the shear strength of the epoxy material. The epoxy samples used to determine the shear strength shall be moulded and cured under the same temperature and humidity conditions as when filling the end fitting.

**6.2.5.3.2** The relationship between shear strength and temperature of the cured epoxy material shall be determined. See API RP 17B for guidelines.

## 6.3 Quality assurance requirements

### 6.3.1 General

**6.3.1.1** All materials used in flexible pipe shall be purchased in accordance with either a written material specification or an industry standard. The specification shall include measurable physical, mechanical, chemical and performance characteristics, and tolerances.

**6.3.1.2** All suppliers to the manufacturer shall have a documented quality assurance system.

**6.3.1.3** As a minimum, materials shall be certified to ISO 10474 3.1B (EN 10204 3.1B). Materials shall be tested at supplier's or manufacturer's workplace in accordance with the requirements of Table 13 of this part of ISO 13628. Test results shall be recorded on material test certificates.

**6.3.1.4** Test results shall conform to the manufacturer's specifications. The results of all tests made by the manufacturer and/or supplier shall be available for review by the purchaser.

**6.3.1.5** For the liner, elastomers shall be 100 % virgin material containing no regrind or other previously processed materials.

**6.3.1.6** Requirements and criteria for surface condition of cables, wires and shaped strips shall be established and documented by the manufacturer. As a minimum, the metallic materials shall have a surface finish free from cracks and hard spots.

**6.3.2 Documentation requirements**

**6.3.2.1** The manufacturer's written specifications for compound ingredients and metallic materials shall include as applicable the requirements of Table 14. The heat treatment procedure shall include cycle time and temperature with tolerances, heat treatment equipment and cooling media.

**6.3.2.2** The specification for end fitting epoxy material shall include, as a minimum, trademark, grade of resin, moulding temperature, and curing temperature and time. In addition, for two-part resins, the specification shall also include grade of hardener, mixing ratio and pot life.

**6.3.3 Storage**

**6.3.3.1** The manufacturer's quality plan shall show procedures for handling, storage and control of raw materials, which reflect the importance of material cleanliness, dryness, purity and traceability during each stage of manufacture.

**6.3.3.2** All hygroscopic raw elastomer material shall be bulk-packaged in sealed containers having a moisture-resistant liner, with vacuum draw-off directly into machine hoppers/dryers to prevent ingress of contaminants. Damaged packages shall be evaluated to determine if the damage has resulted in contamination of the material. Contaminated material shall be rejected.

**6.3.4 Traceability**

**6.3.4.1** Raw materials shall be traceable and suitably marked for easy identification. In the case of elastomer materials, the type of elastomer and the supplier's name and designation shall be identified. The marking of primary end fitting metallic components shall ensure traceability to the base material.

**6.3.4.2** Compound material shall be suitably marked per batch for easy identification. This identification is to be carried through to the finished pipe product so as to ensure traceability of the compound used in the production.

**Table 13 — Minimum quality control test requirements – Raw material**

Material	Test	Frequency	Comments
Elastomers <sup>c</sup>	Composition	One per batch	Purity or weight percent of all additives
Metallic cables and strips	Chemical composition	One per batch	All metals
	Tensile test	One per coil <sup>a</sup>	All cables
	Dimensions	Two per coil	All cables. Start and end of coil. ASTM A480 <sup>[14]</sup> procedures.
End fittings	Chemical composition	One per heat <sup>b</sup>	Body material
	Tensile test	Two per heat	Body material
	Charpy V-notch	One set per heat	Body material; subject to 6.2.5.1.5 and 6.2.5.1.6.
	Hardness test	One per heat	Body material; subject to 6.2.5.1.7.
	Radiography	One	Welded neck only
	100 % Ultrasonic	Each	Body Material
Epoxy	Compression test	Three per injection <sup>d</sup>	Refer to 7.7.4.2, or shear test as specified in 6.2.5.3.

<sup>a</sup> A coil is an order lot of cable not greater than 3 000 kg (6 614 lb) and from the same forming process and heat treatment batch.

<sup>b</sup> "Per heat" refers to heat treatment batch.

<sup>c</sup> Elastomer in the context of this table refers to the material prior to curing.

<sup>d</sup> Per injection refers to injection of each end fitting with epoxy resin.

Table 14 — Requirements of material specifications

Requirements	Metallic material	Compound ingredients
Material composition / chemistry requirements, with tolerances	X	X
Generic base elastomer (ASTM D1418)	—	X
Physical and mechanical property requirements	X	X
Allowable melting and forming practices	X	—
Heat treatment procedures	X	—
Storage and age control requirements	X	X
NDE requirements	X	—
Acceptance and/or rejection criteria	X	X
Certification and records requirements	X	X
Marking, packaging, handling and traceability requirements	X	X
NOTE Some of the requirements might not be applicable to all compound ingredients.		

## 7 Manufacturing requirements

### 7.1 Quality assurance requirements

#### 7.1.1 General

**7.1.1.1** Manufacturing operations shall be performed in accordance with the manufacturer's written specifications and procedures, which shall conform with the requirements of 7.1. Special processes, including curing, welding, heat treatment and coating, shall be performed in accordance with the requirements of 7.9. The manufacturer shall maintain documentation on the qualification of special processes for review by the purchaser or a mutually agreed representative.

**7.1.1.2** NDE shall be performed in accordance with the requirements of ISO 13665 (magnetic particle test), ASTM E165 (liquid penetrant test), ASTM A388 and ASTM E428 (ultrasonic test), and ASTM E94 and ASTM E94 (radiographic test), as applicable.

NOTE For the purpose of this provision, ASTM E709 is equivalent to ISO 13665.

**7.1.1.3** Quality control requirements for materials to be used in the pipe manufacture shall be as specified in 6.3.

#### 7.1.2 Documentation

**7.1.2.1** All processing which converts or affects material properties, including welding and plastic deformation of metals, shall be documented in the manufacturer's specifications and procedures. The specifications and procedures shall include a statement of applicable scope, limits on critical process parameters, inspection and test methods and acceptance/rejection criteria. The manufacturer's specifications and procedures shall be approved by the designated personnel of engineering and manufacturing, shall be controlled documents, and shall be readily available to the process machine operator.

**7.1.2.2** The manufacturer's specification and procedures documentation shall be available for review by the purchaser and shall document the following as a minimum.

- a) Layer-by-layer and step-by-step description of the manufacturing procedures, including quality control and NDE, for the complete flexible pipe, i.e. all layers, sublayers, end fittings and any other items forming an integral part of the final product. Procedures for special processes shall be documented.

- b) The documentation shall include references to specifications and sources of all materials used in the manufacture of the flexible pipe, including the materials used for the manufacture of the layers, and materials such as breaker materials, corrosion coating materials and non-metallic tapes.
- c) The manufacturer shall document all parameters related to the quality of the final product that can be monitored during the manufacturing process. Both nominal values and ranges of these parameters shall be specified.

**7.1.2.3** The manufacturer shall keep on file for the service life of the pipe all documentation pertaining to the pipe manufacture, including manufacturing records, certificates, inspection and factory acceptance test documentation.

### 7.1.3 Process control

All the main steps in the manufacturing process shall be subject to inspection. The manufacturer's quality plan shall specify inspection points, inspection methods and acceptance criteria. Results of all inspections shall be recorded. The manufacturer shall record every non-conformance verified during manufacture of the pipe. Process control shall be performed as a minimum for the following manufacturing processes.

- a) Carcass: preparation and winding of flat steel strip, welding of flat steel strip sections, preforming, cold forming of carcass, reeling of interlocked carcass, preheating and drying prior to extrusions.
- b) Elastomer layers: mixing of raw materials, winding of elastomer layers, curing of pipe and reeling of pipe.
- c) Calendering: cylinder temperatures, cylinder relative speeds and duration of calendering.
- d) Reinforcing layers: preparation of steel cables, feeding of pipe and winding of reinforcement.

### 7.1.4 Handling during manufacture

**7.1.4.1** The manufacturer shall have documented procedures for handling of intermediate and finished products during manufacture, packing and storage. The procedures shall include requirements for limits on pipe abrasion, mechanical damage, torsion, bending and crushing, when winding/unwinding pipe on reels and carousels, or during end fitting assembly and when removing pipe from mandrel.

**7.1.4.2** The condition of all reels and carousels shall be such that any damage induced in the pipe is within the limits specified in the documented handling procedures.

**7.1.4.3** The manufacturer shall use documented procedures for the handling of flat or shaped wires carcass from supplier's shipping reel to the manufacturer's reel, bobbin or mandrel.

**7.1.4.4** Manufacturer's procedures shall include a plan for inspection and refurbishment of forming tools and rollers.

## 7.2 Carcass

### 7.2.1 General

**7.2.1.1** The carcass profile shall be determined at the start and end of each production run to be in accordance with the documented acceptance criteria. The occurrence of sharp edges in the formed carcass layer shall be prevented.

**7.2.1.2** For carcass layers made up in sections, the join-up procedures for the sections shall be documented. The manufacturer shall avoid join-up welds in the touchdown-point-riser area and should minimize the number of carcass join-up welds used along the flexible pipe.

## 7.2.2 Inspection and acceptance criteria

**7.2.2.1** The external surface of the as-formed carcass shall be visually examined for flaws, including dents, cracks, scratches, shavings, gouges, wire deformation or lamination, corrosion, lack of interlock, discoloured areas (blurring, scorching, staining, etc., except at welds), distorted or buckled strip profile and significant scoring. Acceptance criteria for flaws shall be documented by the manufacturer. Unacceptable flaws shall include corrosion, wire lamination, cracks, lack of interlock and twist.

**7.2.2.2** The outside diameter and ovality shall be measured and interlock checked, at the start of the production run. Subsequent to this, these parameters shall be controlled (measured or checked) at intervals verified by the manufacturer to be acceptable. All results shall be recorded and shall be to manufacturer's specifications, which shall conform to the requirements of 7.10.

**7.2.2.3** For carcass sections that are not manufactured on a mandrel, the internal diameter shall be measured and recorded at least every 10 m (32.8 ft) and shall be within the tolerances specified in 7.10. For carcass formed over another pipe layer, the outer diameter shall be measured at least every 10 m (32.8 ft) if it is not possible to measure the inner diameter.

## 7.3 Preparation of compound and calendering

### 7.3.1 General

Preparation of compound materials and calendering shall be performed in accordance with the manufacturer's documented procedures.

### 7.3.2 Preparation of compound

During preparation, the following process parameters shall be monitored and recorded, and shall conform to the manufacturer's specifications:

- a) sequence of mixing;
- b) rate and duration of mixing;
- c) timing of addition of curing agent;
- d) degree of vulcanization after mixing.

### 7.3.3 Calendering

During calendering, the following process parameters shall be monitored and recorded, and shall conform to the manufacturer's specifications:

- a) cylinder temperatures;
- b) cylinder relative speeds;
- c) duration of calendering.

### 7.3.4 Inspection and acceptance criteria

A visual examination of the calenderized layer external surface shall be performed to identify flaws, including bubbles/voids, inclusions, discolouring, surface irregularities, notches and indentations. All flaws shall be in accordance with the manufacturer-specified acceptance criteria.

**7.3.5 Test requirements**

Minimum test and inspection requirements shall be as specified in Table 15 and all results shall be in accordance with manufacturer's specifications and procedures and recorded on material test certificates.

**Table 15 — Minimum material quality control test requirements – Compound**

Material	Test	Frequency	Comments
—	Composition	One per mixer load	Measure weight of all additives to be placed in the mixer.
Compound	Density/specific weight	One per mixer load	ISO 2781
—	Rheology and degree of cure	One per mixer load	ASTM D2084
—	Hardness	One per ten mixer loads or less	ISO 868 <sup>a</sup>
—	Tensile test	One per ten mixer loads or less	ASTM D412
—	Elongation at break	One per ten mixer loads or less	ASTM D412
NOTE If metal bonding promoters are included in the compound, one hardness test, one tensile test and one elongation at break test for each mixer load may be substituted for the rheology test.			
<sup>a</sup> For the purpose of this provision, ASTM D2240 is equivalent to ISO 868.			

**7.4 Elastomer winding**

**7.4.1 General**

**7.4.1.1** Winding of elastomer materials shall be performed in accordance with the manufacturer's documented procedures. The procedures shall include requirements for the condition of the elastomer sheet prior to winding and for the condition of the finished layer, such that the layer and underlying or overlying layers meet the manufacturer's specifications.

**7.4.1.2** The manufacturer should ensure that all windings are onto a clean and dry underlying layer.

**7.4.1.3** During winding, the following process parameters shall be monitored and recorded, and shall conform to the manufacturer's specifications and procedures:

- a) feed rate of the winding appliance;
- b) rate of travel.

**7.4.2 Inspection and acceptance criteria**

**7.4.2.1 Visual examination**

**7.4.2.1.1** The manufacturer's specifications and procedures shall document acceptance criteria for flaws as a function of category (individual or cluster), size, position in material thickness, distance between flaws and number. A visual examination of the elastomer layer external surface shall be performed to identify flaws, including bubbles, inclusions, discolouring, surface irregularities, tool scratches, notches and indentations. All flaws shall be in accordance with the manufacturer-specified acceptance criteria.

**7.4.2.1.2** The maximum dimensions of each flaw or combination of flaws shall be such that the total remaining thickness of the layer, after curing, shall be at least equal to the minimum design thickness.

#### 7.4.2.2 Dimensional measurements

Diameter measurements of the wound layers shall be recorded at least every 10 m (32.8 ft) for the first 50 m (164 ft). Subsequent to this, the diameter shall be measured and recorded at intervals verified by the manufacturer to be acceptable.

### 7.5 Reinforcement armour layer

#### 7.5.1 General

**7.5.1.1** The manufacturer shall have documented procedures for the winding of the reinforcing layers onto the pipe, which shall ensure that the cables are laid to the design requirements. The procedures shall include requirements for the condition of the cables prior to winding and for the condition of the finished layer, such that the layer and underlying or overlying layers meet the manufacturer's specifications.

**7.5.1.2** The procedures shall specify all parameters and allowable tolerances, which are to be monitored and recorded at intervals verified by the manufacturer to be acceptable. The recorded values shall conform to manufacturer's specifications. As a minimum, diameter, pitch (or lay angle) and density of the cables over the pipe surface shall be measured.

**7.5.1.3** No welding or joining of reinforcement armour cables shall be allowed. Overlapping of reinforcing cables shall be allowed provided the manufacturer has documented evidence to support the effectiveness of such a procedure including minimum permissible overlap length.

#### 7.5.2 Inspection and acceptance criteria

The outside diameter shall be measured and recorded at least every 10 m (32.8 ft) for the first 50 m (164 ft) and subsequently at intervals verified by the manufacturer to be acceptable. The results shall be within the tolerances specified in 7.10.

### 7.6 Insulation layers

#### 7.6.1 General

The manufacturer shall ensure that insulation layers are applied in accordance with documented procedures. The procedures shall document acceptance criteria for workmanship and defects.

#### 7.6.2 Inspection and acceptance criteria

**7.6.2.1** The external surface of the insulation layers shall be visually examined over the entire length for flaws, including damage, distortion and folds. Identified flaws shall conform to the manufacturer's specifications.

**7.6.2.2** The outside diameter shall be measured and recorded at least every 10 m (32.8 ft) for the first 50 m (164 ft) and subsequently at intervals verified by the manufacturer to be acceptable. The results shall be within the tolerances specified in 7.10.

### 7.7 End fitting

#### 7.7.1 General

All operations in the manufacture, machining, assembly and inspection of end fittings shall be performed in accordance with the manufacturer's specifications and procedures, which shall meet the requirements of 7.7.

## 7.7.2 Assembly

**7.7.2.1** Before mounting the end fitting on to the pipe, all exposed surfaces shall be cleaned, dried and visually inspected, and confirmed to be in accordance with the requirements of the manufacturer's specifications and procedures.

**7.7.2.2** Control features shall be established and documented to ensure that overheating of epoxy or elastomer layers is prevented during welding operations.

**7.7.2.3** Prior to mixing the epoxy resin all equipment required for the filling operation shall be checked for proper functioning. The mixing and curing of epoxy resin shall be in accordance with the supplier's specifications. Filling shall be carried out in such a way that voids do not occur.

## 7.7.3 Inspection and acceptance criteria

**7.7.3.1** For the end-fitting assembly, hold points shall be included where visual examination, dimensional control and component identification are performed. Results from all inspections shall be documented.

**7.7.3.2** For components requiring a specific tightening force or torque, including swaging machines, it shall be verified using suitable and calibrated equipment that the specified value has been obtained.

**7.7.3.3** The manufacturer shall use a qualified and documented procedure to verify that sufficient epoxy resin has been injected into the end fitting such that no voids are left in the end fitting which would affect its functional performance. It is recommended that the volume injected be checked by measuring the mass of injected epoxy.

## 7.7.4 Test requirements

**7.7.4.1** Minimum test and inspection requirements for primary end fitting components shall be as follows and all results shall be in accordance with manufacturer's specifications and procedures:

- |   |  |
|---|--|
| a) all surfaces:                        | 100 % visual examination;  |
| b) carbon and low alloy steel surfaces: | 100 % magnetic particle or liquid-penetrant inspection when geometry prevents MPI; |
| c) weld overlay surfaces:               | 100 % liquid penetrant;  |
| d) end fitting bodies:                  | 100 % ultrasonic test;   |
| e) circumferential butt welds:          | 100 % radiographic test.   |

**7.7.4.2** On completion of epoxy resin injection, a minimum of three samples shall be taken from the same mix as used for the end fitting. Results from compression strength tests, carried out in accordance with ASTM D695 procedures or shear strength tests, shall be within the range specified by the manufacturer for the cured epoxy. See API RP 17B for guidelines on shear test.

## 7.7.5 Connectors

All end fitting connectors and components shall be in accordance with ISO 10423, ISO 13628-4, other recognized industry standard or as specified by the purchaser, and shall meet the requirements specified in 4.6.1.9.

NOTE 1 For the purpose of this provision, API Spec 6A<sup>[7]</sup> is equivalent to ISO 10423.

NOTE 2 For the purpose of this provision, API Spec 17D is equivalent to ISO 13628-4.



## 7.8 Curing process

### 7.8.1 General

All operations in the curing process shall be performed in accordance with the manufacturer's documented procedures (see 7.9.4).

### 7.8.2 Handling

**7.8.2.1** The manufacturer shall have documented procedures for handling the pipe during construction.

**7.8.2.2** The manufacturer shall use documented procedures for removing the pipe from mandrels after curing.

### 7.8.3 Inspection and acceptance criteria

#### 7.8.3.1 Visual inspection

Visually inspect in accordance with manufacturer's workmanship procedures and standards.

#### 7.8.3.2 Dimensional measurements

Diameter measurements of the vulcanized pipe shall be recorded at least every 10 m (32.8 ft). Measurements shall be taken after the cooling process. Measured results shall be within the manufacturer's specified requirements.

#### 7.8.3.3 Test requirements

**7.8.3.3.1** The tests shall be performed on samples from materials taken from the first pipe and on samples representative of every tenth pipe thereafter. The tests may be performed on a test piece/coupon that accurately represents the pipe construction (reinforcing layer lay angles may be changed from the actual pipe reinforcing lay angle for convenience of manufacture and testing of sample) and is subjected to the same curing regime as the pipe. The sample shall be stored at room temperature for a minimum of 6 h prior to testing. The following tests shall be performed on the sample in accordance with the procedures specified in Table 11 [tests 7.8.3.3.1 b), c), d), e) and f) should be performed for the material of the pipe liner and cover only]:

- a) adhesion between elastomer layers and between elastomer and reinforcement cables;
- b) hardness of elastomer;
- c) tensile strength of elastomer;
- d) elongation at break of elastomer;
- e) density of material;
- f) swelling of material.

**7.8.3.3.2** All test results shall be recorded and shall conform to the manufacturer's specifications.

**7.8.3.3.3** The sample shall also be dissected and inspected for voids in accordance with manufacturer's procedures. The acceptance criterion shall be that no visible voids are present.

## 7.9 Special processes

### 7.9.1 Welding

#### 7.9.1.1 Qualification

**7.9.1.1.1** All welding operations shall be performed by qualified welders in accordance with the manufacturer's approved procedures. Welding procedure specifications (WPS), welding procedure qualification records (WPQR) and welder qualifications shall be documented, and shall be available for review by the purchaser. Welding procedure qualifications shall be witnessed and approved, and records of welder qualification shall be reviewed by a third party, who is qualified to witness and approve the standards and criteria being used. For welding that is conducted using automated processes or welds that serve as manufacturing aids, the third-party witness of welder qualifications may be substituted by an ASNT-qualified Level II inspector. Welders and welding procedures shall be qualified according to API Standard 1104, ASME Section IX, EN 287-1, EN 288 or equivalent. Procedures shall include acceptance/rejection criteria.

**7.9.1.1.2** The manufacturer shall have documented procedures for storage, handling and drying of welding consumables.

#### 7.9.1.2 Carcass

**7.9.1.2.1** Strip welds for carcass join-up shall be subjected to a visual examination. Results from all tests shall be documented and shall be within manufacturer's specifications and procedures.

**7.9.1.2.2** Weld metal for carcass join-up shall be ground smooth to prevent damage to adjoining elastomer layers.

**7.9.1.2.3** Butt welds for joining carcass strips, and carcass join-up welds, shall be subjected to the following inspection requirements:

- a) carcass strip: 100 % visual examination;
- b) carcass join-up: 100 % visual examination.

**7.9.1.2.4** The 100 % visual examination shall be performed prior to the steel passing through the machine forming tools. The external surface of the weld shall also be examined for cracks after passing through the forming tools. Cracks shall not be allowed.

#### 7.9.1.3 End fitting

All circumferential butt and overlay welds shall be performed in accordance with qualified and documented procedures. Inspection and test requirements shall be as specified in 7.7.4.1.

### 7.9.2 Heat treatment

Cables and cold-worked or forged components, which require heat treatment in order to meet specified requirements for strength, formability or NACE compliance, shall be heat treated in accordance with the manufacturer's specifications. The heat-treatment procedures and charts shall be maintained by the manufacturer or subcontractor for review by the purchaser.

### 7.9.3 Coating

**7.9.3.1** Coatings applied to end-fitting components to limit corrosion due to internal or external environments shall be applied in accordance with the manufacturer's documented procedures, which shall include acceptance and rejection criteria.

**7.9.3.2** The procedure for qualification of the metallic coating processes to be applied to the end fitting shall specify the following as a minimum:

- a) bath composition;
- b) control of temperature and time for heat treatments;
- c) hardness test of coating;
- d) adhesion test of coating;
- e) optical microscopy or a similar method recommended to analyse the cross-section of the coated surface;
- f) coating thickness measurement;
- g) testing to confirm the resistance of coating to corrosion agents (e.g. seawater and CO<sub>2</sub>);
- h) procedures for checking surface coating for flaws.

#### **7.9.4 Pipe wall lay-up**

**7.9.4.1** All curing process operations shall be performed in accordance with the manufacturer's qualified and documented procedures. As a minimum, the procedures shall specify:

- a) the applicable compound designations;
- b) the process equipment to be used;
- c) the process aids, consumable and/or auxiliary materials allowed;
- d) the process sequence;
- e) the allowable range for each required process variables or machine setting (speeds, temperatures, times, pressures, etc.);
- f) the specific process variable records (parameter and frequency) to be kept;
- g) accept/reject criteria.

**7.9.4.2** All curing process procedures shall be qualified by testing for each compound used, although a procedure may be qualified for more than one compound. Procedure qualification shall be based on the destructive examination of a qualification sample made using the written procedures, compound, and process equipment being qualified. Qualification samples shall have a minimum inside diameter of 76,2 mm (3 in) and a minimum length of 0,5 m (1.6 ft) and shall be confirmed by the tests given in 7.8.3.3 to conform to requirements documented by the manufacturer. Qualification may be based on samples produced for other prototype or test purposes such as burst or dynamic fatigue.

**7.9.4.3** Qualification samples shall conform to all specified requirements. Each qualification sample shall be cut in half lengthwise and the half shells shall be cut radially into three approximately equal lengths. The carcass layer should be removed to expose the elastomer surface beneath it. When the sample pieces are inspected on all surfaces at ×1 magnification, there shall be no evidence of lack of cure, lack of fusion between adjacent layers, blistering, voids, inclusions, or other flaws. Damage due to the dissection process should be ignored. Samples of the material shall meet the requirements of 7.8.3.3. Complete records of qualification sample preparation, testing and findings shall be retained and be available for review by purchasers or their representatives.

## 7.10 Manufacturing tolerances

**7.10.1** The manufacturer shall document the tolerances to be used for each layer of the flexible pipe. These tolerances shall be verified in the design process to be acceptable, such that the functional requirements of the individual layers and pipe are unaffected by variations within the specified tolerances. As a minimum, tolerances shall be specified for the following parameters:

- a) carcass : external diameter;
- b) elastomer layers: vulcanized thickness and external diameter;
- c) reinforcing layers: external diameter and pitch (or lay angle);
- d) cured pipe: external diameter.

**7.10.2** The tolerance for the length of the flexible pipe should be as specified by the purchaser. If no tolerance is specified by the purchaser, the manufacturer shall specify the tolerance used in the design premise (see 8.2).

**7.10.3** If dimensional criteria are based on manufacturing considerations rather than design considerations, the manufacturer shall document that the criteria used meet the design requirements.

**7.10.4** The maximum gap between cables is one cable diameter.

## 7.11 Repairs

**7.11.1** The manufacturer shall have documented qualified procedures for performing repairs and these procedures shall be available for review by the purchaser. The manufacturer shall document by additional tests and/or calculations that the repairs to the flexible pipe do not compromise the structural or long-term requirements of the pipe.

**7.11.2** Repair of the liner is not permitted. Unacceptable defects found in this layer shall result in the withdrawal of the pipe.

**7.11.3** Minor flaws in the cover layers are permitted. Repairs shall be performed in accordance with qualified procedures. The purchaser shall be permitted to inspect all repairs carried out. Minor flaws are defined as slight unevenness provided that changes in the pipe cover contour are not sharp and not over 3 mm (0.12 in) deep or high at locations of ridges or indentations for submarine pipes and 5 mm (0.2 in) for pipes with integral buoyancy.

**7.11.4** Carcass strip weld repairs are permitted prior to forming, provided a qualified repair procedure is used and visual inspection confirms the weld repair is acceptable. Inspection requirements for repair welds shall be as specified in 7.9.1.

**7.11.5** Procedures for repair of damage to surface protection coatings shall be available for review by the purchaser.

**7.11.6** Butt welds shall meet the requirements of 7.9.1.3. Repair welding shall comply with all the applicable guidelines of ISO 10423 for PSL 2-3. No weld repairs are permitted for PSL 4.

NOTE For the purpose of this provision, API Spec 6A<sup>[7]</sup> is equivalent to ISO 10423.

## 8 Documentation

### 8.1 General

**8.1.1** The minimum documentation that the manufacturer is to have available for the purchaser shall be as specified in Clause 8. The documentation requirements for materials and manufacturing shall be as specified in the relevant subclauses of this part of ISO 13628.

**8.1.2** The manufacturer shall have available for the purchaser the following documents and should have them available at the specified times:

- |                                |                       |
|--------------------------------|-----------------------|
| a) design premise:             | prior to pipe design; |
| b) design load report:         | prior to manufacture; |
| c) design report:              | prior to manufacture; |
| d) manufacturing quality plan: | prior to manufacture; |
| e) fabrication specification:  | prior to manufacture; |
| f) as-built documentation:     | with supplied pipe;   |
| g) operation manual:           | prior to delivery.    |

**8.1.3** Issue of the above documents by manufacturer to purchaser shall be in accordance with the requirements of 4.6.1.1.2.

### 8.2 Design premise

The design premise shall contain the parameters specified in Table 16. If the manufacturer has made assumptions on any of the parameters in Table 16, then it shall be specified in the design premise that the values are assumed.

### 8.3 Design load report

The design load report shall include results from analyses of load cases defined in the design premise. Calculated stresses and strains shall be reported for each design load case. The design load report may be incorporated into the design report.

### 8.4 Design report

**8.4.1** The design report shall contain a detailed description, including drawings, of each pipe component. The description shall include a layer by layer description of the pipe, including materials, carcass strip cross-section, lay angle, diameter, thickness, number of cables, etc.

**8.4.2** Unless separate material specification documentation is issued, material specification and data shall be included in the design report. Material data shall include yield or tensile strengths and fatigue parameters for dynamic service (S-N curve slopes, intercepts and inflection points), and shall identify fluid components that may adversely affect the material.

**8.4.3** Each component shall be documented to have sufficient structural capacity to sustain the design loads and stresses listed in the design load report, with the safety margin specified in the design premise.

**8.4.4** The design report shall specify the following properties for the flexible pipe:

- a) diameters (internal and external);
- b) mass per meter (in air, empty and seawater-filled; and in seawater, empty and seawater-filled);

- c) design pressures;
- d) design temperatures;
- e) design water depth;
- f) MBR (storage and operating);
- g) axial stiffness;
- h) bending stiffness;
- i) torsional stiffness.

**8.4.5** The design report shall define the following properties for the flexible pipe, if specified by the purchaser:

- a) permissible tension (as a function of bend radius);
- b) permissible axial compression;
- c) permissible crushing (radial);
- d) permissible twist (as a function of relevant parameters, if applicable);
- e) pressure- and temperature-induced axial and radial expansion;
- f) pressure- and tension-induced twist;
- g) axial stiffness (in both tension and compression, and as a function of pressure and temperature);
- h) bending stiffness (as a function of tension, pressure and temperature);
- i) torsional stiffness (as a function of twist direction, tension, pressure and temperature).

**8.4.6** The independent verification agent's certificate for the design methodology (see 5.2) shall be included in the design report.

## **8.5 Manufacturing quality plan**

The manufacturing quality plan shall specify all quality control procedures, including inspection points and test procedures. The manufacturing quality plan may be included in the fabrication specification.

## **8.6 Fabrication specification**

The fabrication specification shall describe each step in the manufacturing process, including welding, heat treatment, type and extent of NDE and acceptance criteria, factory acceptance test procedures, fabrication method, and allowable repair procedures. The specification shall ensure that the pipe is in accordance with the design.

## **8.7 As-built documentation**

The as-built documentation shall include, as a minimum, the following:

- a) purchase order reference number;
- b) equipment descriptions;

- c) references to design specifications and drawings;
- d) material certificates;
- e) dimension control measurements, including statistical parameters for continuous processes;
- f) factory acceptance test results;
- g) all non-conformances identified during manufacture and repairs performed;
- h) welding procedure specifications and qualifications;
- i) welder qualification records;
- j) NDE operator qualifications and NDE test records;
- k) heat treatment records.

**Table 16 — Documentation requirements for the design premise**

Parameter	Comments
Internal fluid parameters	All relevant internal fluid parameters, including as a minimum the parameters specified in Table 1.
External environment	All relevant external environment parameters, including as a minimum the parameters specified in Table 2.
System description	All relevant system parameters, including as a minimum the parameters specified in 4.6.
Service life	Including, where relevant, maintenance and replacement programmes.
Design load case definition	All potential load cases for the flexible pipe system during manufacture, storage, transport, testing, installation, operation and retrieval shall be addressed. A matrix showing the load cases to be checked for each component of the flexible pipe system shall be established, and shall conform with the requirements of Clause 5.
Design accidental events	All accidental events and combinations of accidental and other loads (functional and environmental) shall be specified. The load cases shall be included in the load case matrix.
Design criteria	Required safety margins and definitions of structural capacity shall be specified for each layer of the pipe and components, and shall conform with the requirements of Clause 5.
Analysis parameters	These shall include hydrodynamic coefficients, structural parameters such as damping models, hydrodynamic wave models, and seabed parameters such as friction coefficients.

## 8.8 Operation manual

**8.8.1** The operation manual shall be prepared for the system and shall address all maintenance tasks and restrictions, and emergency procedures, including repair procedures to be used on board the installation vessel, as specified by the manufacturer or purchaser. The manual shall include the following as a minimum:

- a) layer by layer description of materials and function;
- b) diameters (internal and external);
- c) mass per meter (in air, empty and seawater-filled; and in seawater, empty and seawater-filled);
- d) design minimum and maximum pressure, and test pressures (specify if design pressure is absolute value or differential);
- e) design minimum and maximum temperatures;

- f) design water depth;
- g) installation requirements;
- h) interface requirements;
- i) field inspection requirements;
- j) repair procedures or manufacture contact for repairs;
- k) handling, storage, winding/unwinding procedures;
- l) gas-venting system description and permeation rate;
- m) decompression rate (gas service);
- n) restrictions on internal fluid components (including H<sub>2</sub>S and CO<sub>2</sub>) and inhibitors;
- o) pigging and TFL capabilities;
- p) allowable loads;
- q) maximum time with seawater or inhibited seawater in pipe and inhibitor requirements;
- r) reference for as-built documentation;
- s) procedures should pipe be damaged in handling;
- t) procedures should re-use of the pipe be considered;
- u) reeling/unreeling procedures.

**8.8.2** If specified by the purchaser, a separate installation manual shall be supplied and this shall document the installation procedures.

## **9 Factory acceptance tests**

### **9.1 General**

**9.1.1** The flexible pipe shall be subjected to factory acceptance tests, including gauge, hydrostatic pressure, electrical continuity and electrical resistance, vacuum and kerosene tests as applicable, to verify the manufacture of the pipe to the requirements of this part of ISO 13628. The purchaser shall have the option of witnessing all tests and shall be given appropriate notice of the timing by the manufacturer. The vacuum test and kerosene test shall be performed only on request of the purchaser.

**9.1.2** The hydrostatic test shall be required for all pipes. The electrical continuity and resistance tests shall be required for pipes that are cathodically protected. The gauge and electrical resistance tests are only applicable to rough bore structures. The vacuum and kerosene tests are only applicable to pipes of 11 m (36.1 ft) and shorter.

**9.1.3** The manufacturer's specifications shall specify the minimum time which shall elapse between the completion of the end-fitting mounting (including epoxy curing) or pipe curing and the start of the acceptance tests. The acceptance test programme shall comply with this minimum time.

**9.1.4** A report for each acceptance test shall be submitted to the purchaser. Current certification/ calibration certificates for all test equipment shall be included in the test report. All pressure-recording equipment shall be calibrated against a dead-weight tester at least every three months.



**9.1.5** If the acceptance criteria for a test are not met, the cause of the failure shall be investigated and a report submitted to the purchaser. Proposed corrective actions shall be included in the report. The purchaser shall have the option of either rejecting the pipe or requiring a retest.

**9.1.6** Tests, as applicable (see Table 17), shall be conducted in the sequence listed in Clause 9.

## 9.2 Gauge test

### 9.2.1 Procedure

**9.2.1.1** The gauging pig shall be equipped with (a) disk(s) capable of detecting any unacceptable obstruction.

**9.2.1.2** The minimum diameter of the gauging pig shall be at least 95 % of the nominal ID or 10 mm (0.4 in) smaller than the ID for pipes with an ID less than 200 mm (7.87 in). The thickness of the gauging disk shall be between 5 mm (0.2 in) and 10 mm (0.4 in).

### 9.2.2 Acceptance criteria

The pig shall pass through the bore of the flexible pipe undamaged. Minor scratches and scuffs are acceptable; dents are not acceptable.

## 9.3 Hydrostatic pressure test

### 9.3.1 Procedure

**9.3.1.1** The hydrostatic test pressure shall be 1,5 times the design pressure. Unless otherwise specified, potable water filtered to 100  $\mu$  shall be used as the test fluid for rough bore pipes. The maximum chloride content shall be less than 50 mg/l<sup>7)</sup> for rough bore pipes. If required to protect the internal carcass material, the water shall be chemically inhibited. A suitable dye may be added to assist in leakage detection.

**9.3.1.2** Trapped air shall be removed from the pipe in accordance with manufacturer's procedures.

**9.3.1.3** The pressure shall be gradually increased, at a rate not greater than the manufacturer's test procedure, to no greater than 110 % of the nominal test pressure, and held for a period of at least 2 h to allow for stabilization. If necessary, the pressure shall be cycled to this pressure until stabilization is achieved. The pressure shall be considered stabilized when the pressure drop is less than 1 % in a 1 h period. Pressure shall then be increased to between the nominal test pressure and 110 % of the nominal test pressure.

**9.3.1.4** The timing of the test shall not start until the equipment and pressure-monitoring gauge have been isolated from the pressure source.

**9.3.1.5** The hydrostatic test pressure shall be held for a period not less than 8 h. During the test, pressure and temperature (ambient and internal) shall be recorded at least every 15 min. Depressurization shall be performed at a rate in accordance with the manufacturer's test procedure.

**9.3.1.6** After depressurization, the end-fitting areas shall be visually examined for any sign of permanent deformation or damage in both the pipe and the end fittings.

**9.3.1.7** If a pig has been used for filling or emptying the pipe, the cups shall be examined for damage and wear. Damage or excessive wear shall be recorded and reported to the purchaser.

---

7) Equivalent to parts per million (ppm), a deprecated term.

## 9.3.2 Acceptance criteria

Pressure loss due to all occurrences, excluding external temperature fluctuations, shall not exceed 1 % of the pressure at the start of the 8 h period or 0,2 MPa (2 bar) for pressures under 20 MPa (200 bar). The manufacturer shall have documented procedures to calculate the pressure loss due to external temperature fluctuations. These procedures and calculations shall be verified by an independent verification agent. No leakage shall be observed from the pipe during the test. No permanent deformation or damage shall be observed in the area of the end fittings. Permanent elongation of the pipe shall not exceed 0,7 %. For pipes of 6 m (19.7 ft) and shorter, bolt holes of the flange of one end of the pipe shall remain in line with bolt holes of the flange of the other end of the pipe within a tolerance of one bolt hole diameter.

## 9.4 Electrical continuity and resistance tests

### 9.4.1 Procedure

**9.4.1.1** The electrical continuity and resistance tests shall be performed after the hydrostatic test. If specified by the purchaser, the tests shall also be done prior to the hydrostatic tests.

**9.4.1.2** For electrically continuous pipes, the electrical continuity test shall be performed between the two end fittings. Electrical resistance tests shall be performed between the end fittings and the carcass. Electrical continuity and resistance measurements shall be recorded.

### 9.4.2 Acceptance criteria

The electrical resistance between the internal carcass and the end fittings shall be greater than 1 k $\Omega$  unless the materials are galvanically identical. The electrical resistance between the end fittings shall be less than 1  $\Omega$ /100 m (1  $\Omega$ /328.08 ft) of pipe.

## 9.5 Kerosene test

### 9.5.1 Procedure

This test shall be carried out immediately prior to the vacuum test. The kerosene test is conducted by filling the pipe with kerosene and venting the air. The pipe is pressurized to design pressure that is then maintained for 24 h. After this period, the pipe is depressurized, drained, dried and observed for any blistering, leakage, or separation of the inner tube from the textile reinforcements or from the end fitting.

### 9.5.2 Acceptance criteria

For pipes without a carcass, blistering or leakage shall cause the pipe to be rejected.

## 9.6 Vacuum test

### 9.6.1 Procedure

The adequacy of the vulcanization of the bonded construction pipe is indicated by the bond strength of the liner to the other layers of the pipe. If applicable, a vacuum test is recommended to verify the adequacy of this bond. Each pipe should be vacuum-tested to 0,085 MPa (0,850 bar gauge) for a period of 10 min. Plastic windows should be adapted to both ends of the pipe length so that visual inspection of the interior can be made by utilizing an adequate light source in one end and directing its beam to the other. The pipe should be examined inside as well as outside for any deformities.

### 9.6.2 Acceptance criteria

Collapse of the pipe liner, failure of adhesion between layers within the body of the pipe, blisters and other deformities shall cause the pipe to be rejected.

Table 17 — Factory acceptance test

		1 Gauge test (9.2)	2 Hydrostatic pressure test (9.3)	3 Electrical resistance test (9.4)   Electrical continuity (9.4)		4 Kerosene test (9.5)	5 Vacuum test (9.6)
Without cathodic protection	with carcass	X	X	N/A	N/A	N/A	N/A
	without carcass	N/A	X	N/A	N/A	On customer request, but only max. 11 m (36.1 ft) each end.	On customer request, but only max. 11 m (36.1 ft) each end.
With cathodic protection	with carcass	X	X	X	X	N/A	N/A
	without carcass	N/A	X	N/A	X	Customer may request test on up to 11 m (36.1 ft) at one or each end.	Customer may request test on up to 11 m (36.1 ft) at one or each end.

## 10 Marking and packaging

### 10.1 Marking

**10.1.1** The flexible pipe marking shall be applied to both end fittings, and shall make the pipe permanently identifiable for the specified service life. As a minimum, the following markings shall be applied:

- a) ISO 13628-10 designation;
- b) serial number of pipe;
- c) manufacturer name or mark;
- d) manufacture date;
- e) design pressure (absolute or differential);
- f) storage MBR.

**10.1.2** If requested by the customer, the following markings may be applied:

- a) circular markings at regular intervals with length for reference in installation and survey;
- b) longitudinal strips on risers to assess twist.

### 10.2 Packaging

**10.2.1** The flexible pipe shall be packaged in accordance with the manufacturer's specifications. If stored on reels or carousels, the pipe shall not be subjected to a bend radius less than the storage MBR. The end fittings and connectors shall be wrapped in heavy-duty protections. Both ends of the pipe shall be sealed. The manufacturer's specifications shall include procedures for storage and packaging of integral components mounted on the pipe, including bend stiffeners. Storage blinds, ropes/wires, shackles and other required handling equipment shall be identified in the packaging procedures. The manufacturer's specifications shall include procedures for controlling back tension and closeness of wraps for reels to be used for pipe installation.

**10.2.2** The packaging shall be such that the pipe is protected against all expected environmental occurrences when stored outdoors. A protective cover should be used. The flexible pipe, including end fittings, should not protrude beyond the edges of transport reels, such that abrasive damage could occur to the pipe.

**10.2.3** If the pipe is to be installed off the reel and free flooded, the inboard end fitting shall be vented.

.....

**Annex A**  
(informative)

**Purchasing guidelines**

**A.1 General**

**A.1.1** Table A.1 gives purchasing guidelines for flexible pipes.

**A.1.2** A separate form should be completed for each length of flexible pipe.

**A.1.3** The manufacturer should specify in the design premise the values assumed for all parameters in Table A.1 not specified by the purchaser.

**Table A.1 — Flexible pipe purchasing guidelines**

<b>General information</b>	
Client:	Client reference:
Phone:	Project:
Fax:	Location:
Purchaser's technical contact:	
Conformance to ISO 13628-10 required? <input type="checkbox"/> Yes <input type="checkbox"/> No	Enquiry date:
API Monogram required? <input type="checkbox"/> Yes <input type="checkbox"/> No	Required response date:
<b>General design parameters</b>	
Internal diameter (m):	Maximum axial load (kN):
Length required (m):	Maximum effective tension (kN):
Tolerance required on length (m ± m):	Torsional balance requirement (°C/m or °F/m):
Pipe structural requirements (MBR, bend stiffness):	Compression strength requirement (kN):
	Design load case probabilities (1 year, 100 years)
Mass requirements (kg/m) in air empty:	Installation:
External protection requirements (external carcass):	Normal operation:
Service life (years):	Abnormal operation:
Specification of normal and abnormal load cases, including accidental loads, and definition of load combinations to be used in the design:	
<small>°C = degree Celsius; °F = degree Fahrenheit; g = gram; K = kelvin; kg = kilogram; kJ = kilojoule; kN = kilonewton; KOH = potassium hydroxide; kPa = kilopascal; l = litre; m = metre; MBR = minimum bend radius; mg = milligram; MPa = megapascal; ppm = parts per million (deprecated unit); TAN = titrated acid number; TFL = through flowline; W = watt</small>	

Table A.1 (continued)

Internal fluid parameters	
<b>General</b>	<b>Flow rate and thermal calculations</b>
Fluid description (oil, gas, water):	Flow rate (m <sup>3</sup> /day):
Flow regime description (single, phase, slug):	Fluid density (kg/m <sup>3</sup> ):
Flow direction:	Viscosity (Pa·s):
<b>Pressures</b>	Minimum inlet pressure (MPa):
Design pressure (MPa):	Required outlet pressure (MPa):
Operating pressure (MPa):	Fluid heat capacity (kJ/kg·°C):
Vacuum conditions (MPa):	<b>Fluid compositional data</b>
Differential internal pressure (MPa):	NaCl content (mass percent of water):
<b>Temperatures</b>	Chloride content (mg/l) <sup>8)</sup> :
Design minimum temperature (°C):	Gas-oil ratio (m <sup>3</sup> /m <sup>3</sup> ):
Design maximum temperature (°C):	Water cut (volume percent):
Operating inlet temperature (°C):	Alcohols? <input type="checkbox"/> Yes <input type="checkbox"/> No
Upset temperature and cycles (°C):	Aromatic components? <input type="checkbox"/> Yes <input type="checkbox"/> No
<b>Service definition</b>	Corrosive agents? <input type="checkbox"/> Yes <input type="checkbox"/> No
Description (sweet/sour):	Inhibitors (scale, paraffin)? <input type="checkbox"/> Yes <input type="checkbox"/> No
ISO 15156 to apply? <input type="checkbox"/> Yes <input type="checkbox"/> No	Injected chemicals? <input type="checkbox"/> Yes <input type="checkbox"/> No
H <sub>2</sub> S partial pressure [MPa; (bar)]:	Solids, precipitates, etc.? <input type="checkbox"/> Yes <input type="checkbox"/> No
CO <sub>2</sub> partial pressure [MPa; (bar)]:	<i>If available, attach details of full fluid compositional data and expected variation over the service life. Also, attach details of any aromatic components, corrosive agents, inhibitors, alcohols, solids, or injected chemicals in the fluid composition.</i>
pH of aqueous phase:	
TAN (mg KOH/g):	

8) Equivalent to parts per million (ppm), a deprecated unit.

Table A.1 (continued)

External environment (static loads)	
Water depths	Soil data
Design water depth (m):	Soil description (clay, sand):
Minimum tidal variation (m):	Soil shear strength (kPa):
Maximum tidal variation (m):	Angle of internal friction (degrees):
Attach details of water depth variation over flexible pipe route.	Lateral friction coefficient:
Air temperatures	Longitudinal friction coefficient:
Minimum temperature (°C):	Seabed scour/sand waves occur? <input type="checkbox"/> Yes <input type="checkbox"/> No
Maximum temperature (°C):	<i>If available, attach seabed profile.</i>
Minimum storage/transport/installation temperature (°C):	Other
Maximum storage/transport/installation temperature (°C):	Marine growth to be considered? <input type="checkbox"/> Yes <input type="checkbox"/> No
Seawater data	<i>If yes, attach details.</i>
Density:	Ice effects to be considered? <input type="checkbox"/> Yes <input type="checkbox"/> No
pH value:	<i>If yes, attach details.</i>
Minimum surface temperature (°C):	Sunlight exposure? <input type="checkbox"/> Yes <input type="checkbox"/> No
Maximum surface temperature (°C):	Current data attached? <input type="checkbox"/> Yes <input type="checkbox"/> No
Minimum seabed temperature (°C):	<i>Attached current data should be given as a function of water depth, direction and return period.</i>
Maximum seabed temperature (°C):	
External environment (dynamic loads)	
Wave data attached? <input type="checkbox"/> Yes <input type="checkbox"/> No	Wind data attached? <input type="checkbox"/> Yes <input type="checkbox"/> No
<i>Attached wave data should be given in terms of significant wave, maximum wave, equivalent periods, spreading functions, scatter diagrams, as a function of direction, and return period. For irregular seas, the wave spectrum data should be specified.</i>	<i>Attached wind data should be given in terms of maximum 3-sec, 1-min, 10-min, and 1-h wind speeds, as a function of direction, height above water level, and return period.</i>

Table A.1 (continued)

General system requirements	
General	Gas venting
System description (flowline, riser, jumper, subsea, topsides):	Gas-venting required? <input type="checkbox"/> Yes <input type="checkbox"/> No
Application definition (static, dynamic):	System components (valves, burst disks):
Pipe bore description (rough, smooth):	Allowable gas permeation rate (l/m-day):
<b>Corrosion protection requirements</b>	Venting-location restrictions?
Corrosion protection required? <input type="checkbox"/> Yes <input type="checkbox"/> No	Gas-monitoring system?
Cathodic protection system required? <input type="checkbox"/> Yes <input type="checkbox"/> No	<b>Other</b>
Electrical continuity required? <input type="checkbox"/> Yes <input type="checkbox"/> No	Fire resistance required? <input type="checkbox"/> Yes <input type="checkbox"/> No Specify (Lloyds/DNV/API Spec 16C):
End-fitting coatings required? <input type="checkbox"/> Yes <input type="checkbox"/> No	Pigging, TFL, workover, etc. required? <input type="checkbox"/> Yes <input type="checkbox"/> No
External coating description:	Piggyback required? <input type="checkbox"/> Yes <input type="checkbox"/> No
Internal coating description:	<i>If yes, attach details.</i>
If available, allowable electrical resistance, protection voltage, current source, and current density should be specified.	Pressure and tensile armour weld location restrictions? <input type="checkbox"/> Yes <input type="checkbox"/> No
<b>Thermal insulation</b>	Interface definitions/specifications (refer to 4.6.1.10):
Thermal insulation required? <input type="checkbox"/> Yes <input type="checkbox"/> No	
Required outlet temperature (°C):	
Required insulation U-value (W/m <sup>2</sup> K):	Exothermal chemical reaction cleaning required? <input type="checkbox"/> Yes <input type="checkbox"/> No
Insulation U-value should be based on pipe ID and be for the pipe alone. Specify any allowances that can be made for external effects such as soil.	Inspection condition monitoring required? <input type="checkbox"/> Yes <input type="checkbox"/> No  <i>If yes, give details of requirements.</i>
<b>Connector</b>	
Lower connector type (flange, pipe):	
Upper connector type (flange, pipe):	
<i>Attach welding specification seal type and sizes, and responsibility for supply and mounting of components.</i>	



Table A.1 (continued)

<b>Flowline parameters</b>	
Flowline routing description attached? <input type="checkbox"/> Yes <input type="checkbox"/> No	<b>Upheaval buckling</b>
Guides and supports (I-tubes, J-tubes):	Upheaval buckling to be checked? <input type="checkbox"/> Yes <input type="checkbox"/> No
Protection requirements	Required minimum soil coverage (m):
Impact resistance to accidental loads? <input type="checkbox"/> Yes <input type="checkbox"/> No	Allowable bend radius (m):
Trenching? <input type="checkbox"/> Yes <input type="checkbox"/> No	Load cases attached? <input type="checkbox"/> Yes <input type="checkbox"/> No
Rock dumping? <input type="checkbox"/> Yes <input type="checkbox"/> No	<b>Other</b>
Mattresses? <input type="checkbox"/> Yes <input type="checkbox"/> No	On-bottom stability to be checked? <input type="checkbox"/> Yes <input type="checkbox"/> No
Other? <input type="checkbox"/> Yes <input type="checkbox"/> No	Crossover requirements? <input type="checkbox"/> Yes <input type="checkbox"/> No
<i>Attach details of specified protection system(s), including GA drawings, possible accidental occurrences (trawl boards, dropped objects, anchors, and so on), design impact loads.</i>	Required pipe attachments (bend restrictors, clamps): <i>Attach drawings of all items.</i>
<b>Riser parameters</b>	
<b>General</b>	<b>Interference</b>
Riser configuration (lazy-S, steep wave):  <i>Attach description of riser configuration and GA drawing(s) of all relevant details.</i>	Interference/clashing check required? <input type="checkbox"/> Yes <input type="checkbox"/> No  <i>Attach details of all possible interface areas, including other risers, mooring lines, platform columns, vessel pontoons, tanker heel, and so forth, and specify allowable interferences/clashing.</i>
Riser upper connection description (platform, tanker):	<b>Vessel motion data</b>
Riser lower connection description (seabed, vessel):	Vessel motion data attached? <input type="checkbox"/> Yes <input type="checkbox"/> No
Required pipe attachments (bend stiffeners, buoys):  <i>Attach drawings of all items.</i>	<i>Attached vessel motion data should be specified in terms of the following for the relevant loading conditions. Attached data should include a general layout drawing, showing vessel heading, North point, riser(s) in plan, and mooring lines.</i>  <ul style="list-style-type: none"> <li>— Vessel static and dynamic offsets for all conditions.</li> <li>— Vessel data, dimensions, drafts, etc.</li> <li>— Vessel first- and second-order motions, in terms of heave, surge, sway, yaw, roll and pitch.</li> <li>— Vessel motion phase data and specification.</li> <li>— Reference point for motions.</li> <li>— Mooring system design, including line properties and anchor locations.</li> <li>— Position tolerances.</li> </ul>

Table A.1 (continued)

Additional requirements
<p>Materials required in addition to ISO 13628-10 (API Spec 17K)? <input type="checkbox"/> Yes <input type="checkbox"/> No</p> <p><i>If yes, specify details.</i></p>
<p>Manufacturing required in addition to ISO 13628-10 (API Spec 17K)? <input type="checkbox"/> Yes <input type="checkbox"/> No</p> <p><i>If yes, specify details.</i></p>
<p>Selection of PSL Level for 7.11.6 (default is PSL 2-3)? <input type="checkbox"/> Yes <input type="checkbox"/> No</p> <p><i>If yes, specify details.</i></p>
<p>FAT required in addition to ISO 13628-10 (API Spec 17K)? <input type="checkbox"/> Yes <input type="checkbox"/> No</p> <p><i>If yes, specify details.</i></p>
<p>Markings required in addition to ISO 13628-10 (API Spec 17K)? <input type="checkbox"/> Yes <input type="checkbox"/> No</p> <p><i>If yes, specify details.</i></p>
<p>Prototype tests required? <input type="checkbox"/> Yes <input type="checkbox"/> No</p> <p><i>If yes, specify details.</i></p>
<p>Additional national authority/government regulations? <input type="checkbox"/> Yes <input type="checkbox"/> No</p> <p><i>If yes, specify details.</i></p>
<p>Purchaser inspection required? <input type="checkbox"/> Yes <input type="checkbox"/> No</p> <p><i>If yes, specify details.</i></p>
<p>General requirements in addition to ISO 13628-10 (API Spec 17K)? <input type="checkbox"/> Yes <input type="checkbox"/> No</p> <p><i>If yes, specify details.</i></p>

Table A.1 (continued)

<b>Delivery, installation, and maintenance requirements</b>	
Delivery requirements:	
Shipping, packing and storage requirements:	
Documentation requirements:	
<i>Purchaser should specify if a separate installation manual is required.</i>	
<b>Installation requirements</b>	<b>Maintenance</b>
Method:	Maintenance required? <input type="checkbox"/> Yes <input type="checkbox"/> No
Vessel:	<i>If yes, specify details.</i>
General:	
<i>Where relevant, the purchaser should specify any requirements for season, environment, vessel limitations, restrictions due to conflicting activities, and installation scope (including trenching, burial, testing, inspection, surveying, and documentation).</i>	
<b>Installation design criteria</b>	
Equipment bend radius (m):	
Tensioner crush loads (kN):	
Installation/lifting device requirements:	
Transport reel used for installation? <input type="checkbox"/> Yes <input type="checkbox"/> No	
Pipe internal fluid at delivery (empty, water filled):	
Seawater flooding requirements (exposure time?) <input type="checkbox"/> Yes <input type="checkbox"/> No	
<i>Where relevant, the purchaser should specify details such as length of tensioners, shape of tensioner shoes, number of belts, diameter of wheels, reels, ramp angles, and surface shape.</i>	
Installation test requirements:	
Installation vessel motions and offsets attached? <input type="checkbox"/> Yes <input type="checkbox"/> No	
<i>Attached details should, in general, reflect data requirements in vessel motion data requirements listed under riser parameters (above).</i>	

## Annex B (informative)

### Bend stiffeners and bend restrictors

#### B.1 Scope

Annex B gives guidelines on minimum requirements for the design, material selection, manufacture, testing, and marking of non-integral bend stiffeners and bend restrictors, for use in flexible pipe applications. The scope of these guidelines is as specified in Clause 1. If no specific guidelines are given in this annex, reference should be made to the requirements specified for the flexible pipe. Bellmouths are not covered in this annex. See API RP 17B for guidelines on bellmouths.

#### B.2 Definitions

The definitions for bend restrictors and bend stiffeners are as specified in 3.1.6 and 3.1.7, respectively. Bend limiters is used in this annex as a generic term for both bend stiffeners and bend restrictors. The term manufacturer, as used in this annex, refers to the bend limiter supplier. Figure B.1 is an example of a typical bend restrictor.

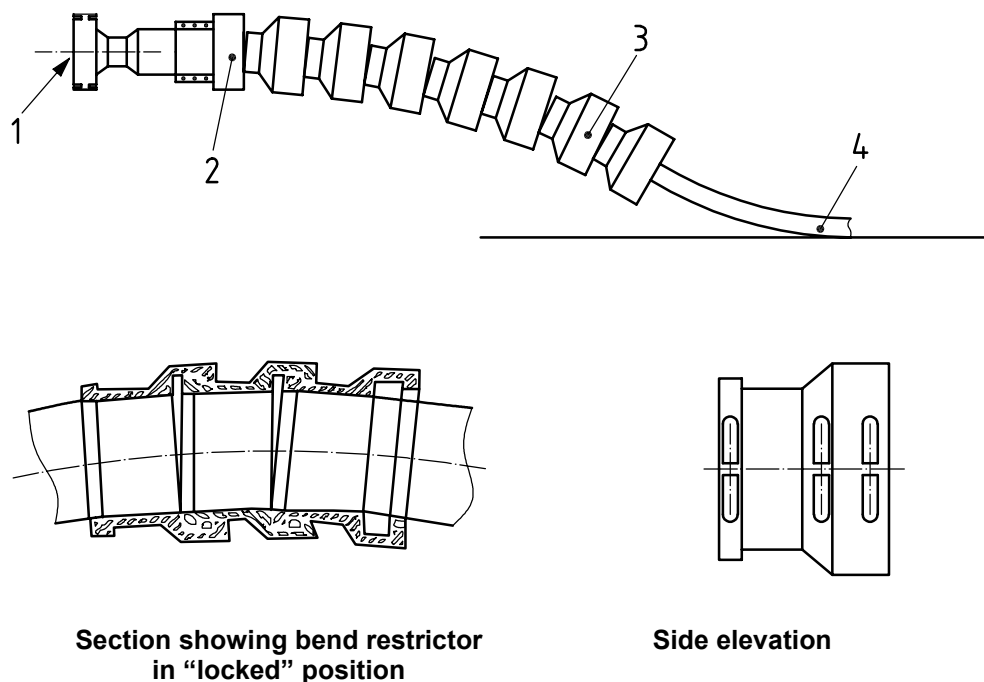

**Key**

- 1 end fitting
- 2 reaction collar
- 3 bend restrictor
- 4 subsea line

**Figure B.1 — Schematic of a bend restrictor**

### B.3 Functional requirements

**B.3.1** The manufacturer should demonstrate that the bend limiter meets the functional requirements specified for the flexible pipe in 4.2.1, as applicable.

**B.3.2** Bend stiffeners are typically used only for dynamic applications, and bend restrictors are typically used only for static applications.

**B.3.3** The manufacturer should define, in consultation with the purchaser and/or flexible pipe manufacturer, the design requirements for the bend limiter. The purchasing guidelines of Table B.1 may be used for specifying the design requirements.

**B.3.4** The design loads for the bend stiffener should be defined in terms of effective tensions and angle variations from the mean. The combinations of tension and angle that are analyzed should be sufficient to cover all possible load cases, with reference to the load cases specified for the flexible pipe in Clause 5. The design loads for bend restrictors should be defined in terms of bending moments, shear forces, and, if applicable, impact loads.

**B.3.5** The designer of the bend limiter should specify all necessary mounting components.

### B.4 Design requirements

**B.4.1** The design methodology for bend limiters should be documented and verified by tests or finite element analyses. The design methodology should be verified by an independent third party.

**B.4.2** The design methodology should account for the effects of wear (abrasion), corrosion, manufacturing processes, shrinkage, creep, and aging (due to mechanical, chemical, and thermal degradation), unless the design is documented to not suffer from such effects. The design methodology should also account for effects of nonlinear material properties, in particular, nonlinear Young's modulus for bend stiffener material.

**B.4.3** For bend stiffeners, the design methodology should consider the following failure modes:

- a) disbonding or rupture in interface with metallic elements;
- b) rupture or cracking in elastomeric material;
- c) long-term material performance (aging);
- d) fatigue;
- e) end-fitting or support-flange mounting failure.

**B.4.4** The design methodology for bend restrictors should consider failure modes B.4.3 c) and (e). The design should ensure that bending moments and shear forces transferred along the length of the bend restrictor do not damage the pipe at either end of the bend restrictor.

**B.4.5** The bend limiter should be designed to meet the requirements of B.3 without permanent deformation or loss of mechanical properties. As a minimum, the manufacturer should demonstrate that the design meets the specified requirements under all possible combinations of temperature and flexible pipe bend stiffness. Ovalization of the bend stiffener tip should be documented to not affect the performance of the bend stiffener.

**B.4.6** The manufacturer should demonstrate that for all possible load case combinations, the bend limiter is designed to the MBR requirements of 5.3.1 and the design requirements (permissible utilization factors) of Table 7.

**B.4.7** The bend limiter design should be compatible with all relevant dimensions of the flexible pipe and end fitting. The design should meet any tolerances for bend-limiter internal diameter that are specified by the manufacturer or purchaser.

**B.4.8** The tolerances used for all components of the bend limiter should be documented not to increase stress or strain levels above specified allowable values.

**B.4.9** If the bend limiter is to be attached to a support structure such as an end fitting, the bend limiter should be designed to safely transfer loads to the support structure. Bend restrictors may be connected at a location remote from the end fitting, requiring clamping directly to the pipe, and in this case the clamping system design should ensure that no damage occurs to the pipe. The design of the bend limiter should ensure that it is restrained axially.

**B.4.10** For dynamic applications, fatigue life calculations or testing should be performed. The predicted fatigue life should be at least ten times the service life.

## B.5 Materials and manufacture

**B.5.1** The bend limiter primary components are typically manufactured from polymer material (elastomeric material for bend stiffeners) and should meet the performance requirements specified in B.4. The polymer material may be reinforced.

**B.5.2** The polymer material property requirements should include the following as a minimum, for the specified range of design temperatures.

- a) Tensile strength: ASTM D638, ASTM D412, ISO 37;
- b) Elongation at break: ASTM D638, ASTM D 412, ISO 37;
- c) Tear strength: ASTM D624, ISO 34-2;
- d) Young's modulus: ASTM D638, ASTM D412, ISO 37;
- e) Stress-strain curve: ASTM D638, ASTM D412, ISO 37;
- f) Hardness: ASTM D2240, ISO 868;
- g) Impact strength: ASTM D256, ASTM D746;
- h) Heat distortion temperature: ASTM D648, ISO 75;
- i) Density: ASTM D792, ISO 2781.

**B.5.3** All materials of the limiter should be resistant to seawater, chemical exposure, ultraviolet exposure, and temperature limits, as applicable, for the specified service life.

**B.5.4** If applicable, the bend-limiter supplier should test and document the effects of water absorption, hydrolysis, creep, and temperature on the elastomeric material used for the primary parts of the limiter, and confirm the suitability of the material for the specified application.

**B.5.5** All metallic components should be protected against corrosion in the specified environment by either material selection, suitable coating, cathodic protection system, or a combination, for the specified service life.

**B.5.6** The manufacturer's specification should define process control requirements for all steps in the manufacture of the bend limiter. The manufacturer's quality plan should specify inspection points, inspection methods, and acceptance criteria. Results of all inspections should be recorded. The manufacturer should record every non-conformance verified during manufacture.

**B.5.7** The manufacturing procedure for the bend stiffener should ensure bonding of the elastomeric material to internal metallic components. The bond should be demonstrated to be stronger than the performance requirement throughout the service life.

**B.5.8** The injection process used in the manufacture of the bend limiter should not leave any voids in the structure that would effect its functionality.

**B.5.9** Injected material samples should be taken at regular intervals from the production run and subjected to tests including tensile strength and hardness. The results of the tests should be to the manufacturer's specifications.

**B.5.10** All components of the bend limiter should be visually examined. In addition, sufficient dimensional measurements should be recorded to ensure that the bend-limiter dimensions are within manufacturer-specified tolerances.

**B.5.11** Bend restrictors may be subjected to factory acceptance tests. The acceptance tests should as a minimum check the MBR under no-load and maximum-load conditions. The results of all tests should be in accordance with the manufacturer's specifications, which should meet the design requirements of B.4. Factory acceptance tests are generally not performed on bend stiffeners because of the difficulty in applying realistic loads without the flexible pipe present.

## B.6 Documentation

**B.6.1** The manufacturer should supply to the purchaser the following documents at the specified times:

- a) design report: prior to manufacture;
- b) manufacturing quality plan: prior to manufacture;
- c) as-built documentation: with supplied pipe.

**B.6.2** The design report should provide sufficient documentation to verify that the requirements of this annex have been met. In addition, the design report should include results from all load case analyses, detail description of bend-limiter, including drawings, and material specification documentation.

**B.6.3** The manufacturing quality plan should specify all quality control procedures, including inspection points and test procedures as required to control the manufacturing activities.

**B.6.4** The as-built documentation should include drawings, design data, dimensional inspection reports, material certificates, and any non-conformance reports and resolutions.

## B.7 Marking and packaging

**B.7.1** The marking for the bend limiter should make the component permanently identifiable for the specified service life. As a minimum, the marking should specify manufacturer and purchaser names, serial number, manufacturing date, and operating MBR. If space is limited, the markings may be reduced to a unique serial number.

**B.7.2** Packaging of the bend limiter should ensure its safety in all transport stages prior to installation.

Table B.1 — Purchasing guidelines for bend limiters

Parameter	Bend restrictor	Bend stiffener	Value/details
<b>General information</b>			
Client:	X	X	
Location:	X	X	
Project:	X	X	
Date:	X	X	
Flexible pipe data			
External diameter and tolerances (m):	X	X	
Structural properties and variations due to temperature, pressure, and other effects:	X	X	
Storage and operating MBR (m):	X	X	
Outer sheath material:	X	—	
End fitting/support structure dimensions and tolerances:	X	X	
<b>Interface requirements</b>			
Termination device:	X	X	
Corrosion protection system:	X	X	
Static offset angle:	X	X	
<b>Bender limiter design limitations/requirements</b>			
Bend limiter external diameter (m):	X	X	
Support point maximum bending moment (kNm):	X	X	
Geometrical restrictions? <input type="checkbox"/> Yes <input type="checkbox"/> No	X	X	
Maximum contact pressure (MPa):	X	—	
Internal fluid temperatures (max internal design condition) (°C):	X	X	
<b>External environment data</b>			
Medium (air, seawater):	X	X	
Water depth (m):	X	X	
Minimum design temperatures (°C):	X	X	
Maximum design temperatures (°C):	X	X	
Sunlight exposure? <input type="checkbox"/> Yes <input type="checkbox"/> No	X	X	
<b>Load cases</b>			
Design:	X	X	
Fatigue:	X	X	
Impact (accidental):	X	—	
Service life:	X	X	
°C = degree Celsius; kN·m = kilonewton meter; m = metre; MPa = megapascal			



**Annex C**  
(informative)

**Use of the API Monogram**

For equipment manufactured in conformance with this part of ISO 13628, API licensees may stamp the API Monogram at the location specified in Clause 10 for the ISO 13628-10 designation.

Specific API requirements must be met in order to apply the API Monogram. For information on these requirements, contact the Manager, API Quality Program, 1220 L Street, NW, Washington, D.C. 20005.

## Bibliography

- [1] ISO 188, *Rubber, vulcanized or thermoplastic — Accelerated aging or heat-resistance tests*
- [2] ISO 13628-2, *Petroleum and natural gas industries — Design and operation of subsea production systems — Part 2: Unbonded flexible pipe systems for subsea and marine applications*
- [3] API RP 17B, *Recommended Practice for Flexible Pipe*
- [4] API RP 17C, *Recommended Practice on TFL (Through Flowline)*
- [5] API Spec 17K, *Bonded flexible pipe*
- [6] API Spec 5L, *Specification for Line Pipe*
- [7] API Spec 6A, *Specification for Wellhead and Christmas Tree Equipment*
- [8] API Spec 16C, *Specification for Choke and Kill Systems*
- [9] API Spec 17D, *Specification for Subsea Wellhead and Christmas Tree Equipment*
- [10] API Spec 17J, *Specification for Unbonded Flexible Pipe*
- [11] ASTM A105, *Standard Specification for Forgings, Carbon Steel, for Piping Applications*
- [12] ASTM A106, *Standard Specification for Seamless Carbon Steel Pipe for High-Temperature Service*
- [13] ASTM A370, *Standard Test Methods and Definitions for Mechanical Testing of Steel Products*
- [14] ASTM A480, *Standard Specification for General Requirements for Flat-Rolled Stainless and Heat-Resisting Steel Plate, Sheet, and Strip*
- [15] ASTM C335, *Standard Test Method for Steady-State Heat Transfer Properties of Horizontal Pipe Insulations*
- [16] ASTM D624, *Standard Test Method for Tear Strength of Conventional Vulcanized Rubber and Thermoplastic Elastomer*
- [17] ASTM D638, *Standard Test Method for Tensile Properties of Plastics*
- [18] ASTM D648, *Standard Test Method for Deflection Temperature of Plastics Under Flexural Load in the Edgewise Position*
- [19] ASTM D792, *Standard Test Methods for Density and Specific Gravity (Relative Density) of Plastics by Displacement*
- [20] ASTM D1044, *Standard Test Method for Resistance of Transparent Plastics to Surface Abrasion*
- [21] ASTM D2240, *Standard Test Method for Rubber Property — Durometer Hardness*
- [22] ASTM D4060, *Standard Test Method for Abrasion Resistance of Organic Coatings by the Taber Abraser*
- [23] ASTM E10, *Standard Test Method for Brinell Hardness of Metallic Materials*

- [24] ASTM E18, *Standard Test Methods for Rockwell Hardness and Rockwell Superficial Hardness of Metallic Materials*
- [25] ASTM E709, *Standard Practice for Magnetic Particle Examination*
- [26] ASTM E831, *Standard Test Method for Linear Thermal Expansion of Solid Materials by Thermomechanical Analysis*
- [27] ASTM E1269, *Standard Test Method for Determining Specific Heat Capacity by Differential Scanning Calorimetry*
- [28] DNV RP B401, *Cathodic Protection Design*
- [29] NACE MR0175, *Metals for Sulfide Stress Cracking and Stress Corrosion Cracking Resistance in Sour Oilfield Environments*
- [30] OCIMF, *Guide to Purchasing, Manufacturing and Testing of Loading and Discharge Hoses for Offshore Moorings*
- [31] ISO 13628-3, *Petroleum and natural gas industries — Design and operation of subsea production systems — Part 3: Through flowline (TFL) systems*

---

---

## **BSI — British Standards Institution**

BSI is the independent national body responsible for preparing British Standards. It presents the UK view on standards in Europe and at the international level. It is incorporated by Royal Charter.

### **Revisions**

British Standards are updated by amendment or revision. Users of British Standards should make sure that they possess the latest amendments or editions.

It is the constant aim of BSI to improve the quality of our products and services. We would be grateful if anyone finding an inaccuracy or ambiguity while using this British Standard would inform the Secretary of the technical committee responsible, the identity of which can be found on the inside front cover.  
Tel: +44 (0)20 8996 9000. Fax: +44 (0)20 8996 7400.

BSI offers members an individual updating service called PLUS which ensures that subscribers automatically receive the latest editions of standards.

### **Buying standards**

Orders for all BSI, international and foreign standards publications should be addressed to Customer Services. Tel: +44 (0)20 8996 9001.  
Fax: +44 (0)20 8996 7001. Email: [orders@bsi-global.com](mailto:orders@bsi-global.com). Standards are also available from the BSI website at <http://www.bsi-global.com>.

In response to orders for international standards, it is BSI policy to supply the BSI implementation of those that have been published as British Standards, unless otherwise requested.

### **Information on standards**

BSI provides a wide range of information on national, European and international standards through its Library and its Technical Help to Exporters Service. Various BSI electronic information services are also available which give details on all its products and services. Contact the Information Centre.  
Tel: +44 (0)20 8996 7111. Fax: +44 (0)20 8996 7048. Email: [info@bsi-global.com](mailto:info@bsi-global.com).

Subscribing members of BSI are kept up to date with standards developments and receive substantial discounts on the purchase price of standards. For details of these and other benefits contact Membership Administration.  
Tel: +44 (0)20 8996 7002. Fax: +44 (0)20 8996 7001.  
Email: [membership@bsi-global.com](mailto:membership@bsi-global.com).

Information regarding online access to British Standards via British Standards Online can be found at <http://www.bsi-global.com/bsonline>.

Further information about BSI is available on the BSI website at <http://www.bsi-global.com>.

### **Copyright**

Copyright subsists in all BSI publications. BSI also holds the copyright, in the UK, of the publications of the international standardization bodies. Except as permitted under the Copyright, Designs and Patents Act 1988 no extract may be reproduced, stored in a retrieval system or transmitted in any form or by any means – electronic, photocopying, recording or otherwise – without prior written permission from BSI.

This does not preclude the free use, in the course of implementing the standard, of necessary details such as symbols, and size, type or grade designations. If these details are to be used for any other purpose than implementation then the prior written permission of BSI must be obtained.

Details and advice can be obtained from the Copyright & Licensing Manager.  
Tel: +44 (0)20 8996 7070. Fax: +44 (0)20 8996 7553.  
Email: [copyright@bsi-global.com](mailto:copyright@bsi-global.com).

BSI  
389 Chiswick High Road  
London  
W4 4AL