

**BS EN ISO 13132:2011**



**BSI Standards Publication**

# **Laboratory glassware — Petri dishes (ISO 13132:2011)**

**bsi.**

...making excellence a habit.™

### **National foreword**

This British Standard is the UK implementation of EN ISO 13132:2011.

The UK participation in its preparation was entrusted to Technical Committee LBI/36, Laboratory glassware and related apparatus.

A list of organizations represented on this committee can be obtained on request to its secretary.

This publication does not purport to include all the necessary provisions of a contract. Users are responsible for its correct application.

© BSI 2011

ISBN 978 0 580 68043 4

ICS 71.040.20

**Compliance with a British Standard cannot confer immunity from legal obligations.**

This British Standard was published under the authority of the Standards Policy and Strategy Committee on 31 August 2011.

### **Amendments issued since publication**

Date	Text affected
------	---------------

---

ICS 71.040.20; 11.100.01

English Version

## Laboratory glassware - Petri dishes (ISO 13132:2011)

Verrerie de laboratoire - Boîtes de Petri (ISO 13132:2011)

Laborgeräte aus Glas - Petrischalen (ISO 13132:2011)

This European Standard was approved by CEN on 14 July 2011.

CEN members are bound to comply with the CEN/CENELEC Internal Regulations which stipulate the conditions for giving this European Standard the status of a national standard without any alteration. Up-to-date lists and bibliographical references concerning such national standards may be obtained on application to the CEN-CENELEC Management Centre or to any CEN member.

This European Standard exists in three official versions (English, French, German). A version in any other language made by translation under the responsibility of a CEN member into its own language and notified to the CEN-CENELEC Management Centre has the same status as the official versions.

CEN members are the national standards bodies of Austria, Belgium, Bulgaria, Croatia, Cyprus, Czech Republic, Denmark, Estonia, Finland, France, Germany, Greece, Hungary, Iceland, Ireland, Italy, Latvia, Lithuania, Luxembourg, Malta, Netherlands, Norway, Poland, Portugal, Romania, Slovakia, Slovenia, Spain, Sweden, Switzerland and United Kingdom.



EUROPEAN COMMITTEE FOR STANDARDIZATION  
COMITÉ EUROPÉEN DE NORMALISATION  
EUROPÄISCHES KOMITEE FÜR NORMUNG

**Management Centre: Avenue Marnix 17, B-1000 Brussels**

## Foreword

This document (EN ISO 13132:2011) has been prepared by Technical Committee ISO/TC 48 "Laboratory equipment" in collaboration with Technical Committee CEN/TC 332 "Laboratory equipment" the secretariat of which is held by DIN.

This European Standard shall be given the status of a national standard, either by publication of an identical text or by endorsement, at the latest by January 2012, and conflicting national standards shall be withdrawn at the latest by January 2012.

Attention is drawn to the possibility that some of the elements of this document may be the subject of patent rights. CEN [and/or CENELEC] shall not be held responsible for identifying any or all such patent rights.

According to the CEN/CENELEC Internal Regulations, the national standards organizations of the following countries are bound to implement this European Standard: Austria, Belgium, Bulgaria, Croatia, Cyprus, Czech Republic, Denmark, Estonia, Finland, France, Germany, Greece, Hungary, Iceland, Ireland, Italy, Latvia, Lithuania, Luxembourg, Malta, Netherlands, Norway, Poland, Portugal, Romania, Slovakia, Slovenia, Spain, Sweden, Switzerland and the United Kingdom.

### Endorsement notice

The text of ISO 13132:2011 has been approved by CEN as a EN ISO 13132:2011 without any modification.

## Foreword

ISO (the International Organization for Standardization) is a worldwide federation of national standards bodies (ISO member bodies). The work of preparing International Standards is normally carried out through ISO technical committees. Each member body interested in a subject for which a technical committee has been established has the right to be represented on that committee. International organizations, governmental and non-governmental, in liaison with ISO, also take part in the work. ISO collaborates closely with the International Electrotechnical Commission (IEC) on all matters of electrotechnical standardization.

International Standards are drafted in accordance with the rules given in the ISO/IEC Directives, Part 2.

The main task of technical committees is to prepare International Standards. Draft International Standards adopted by the technical committees are circulated to the member bodies for voting. Publication as an International Standard requires approval by at least 75 % of the member bodies casting a vote.

Attention is drawn to the possibility that some of the elements of this document may be the subject of patent rights. ISO shall not be held responsible for identifying any or all such patent rights.

ISO 13132 was prepared by Technical Committee ISO/TC 48, *Laboratory equipment*, Subcommittee SC 6, *Glass and plastics ware including volumetric instruments*.



# Laboratory glassware — Petri dishes

## 1 Scope

This International Standard specifies requirements and tests for glass Petri dishes intended for general laboratory purposes and microbiological work.

## 2 Normative references

The following referenced documents are indispensable for the application of this document. For dated references, only the edition cited applies. For undated references, the latest edition of the referenced document (including any amendments) applies.

ISO 719, *Glass — Hydrolytic resistance of glass grains at 98 °C — Method of test and classification*

## 3 Types

Two types of Petri dishes are specified in this International Standard.

Type 1 – Thick-walled Petri dishes

Type 2 – Thin-walled Petri dishes

## 4 Nominal sizes and series

### 4.1 Nominal sizes

Petri dishes shall have the following nominal sizes.

50, 60, 80, 100, 120, 150 and 200 millimetres

NOTE For Series B, nominal sizes refer to the external diameter of the bottom dish.

### 4.2 Series

Petri dishes shall comply with the following dimensional requirements.

Series A – Dimensions in accordance with Table 1

Series B – Dimensions in accordance with Table 2

## 5 Designation

Petri dishes in accordance with this International Standard shall be designated by their nominal size followed by the type and the series.

Designation of a thick-walled Petri dish with nominal size of 120 mm, Type 1, Series A:

Petri dish ISO 13132 – 120 × 20 – 1A

If bottom dishes (2) and top dishes (1) are ordered separately, the following designations shall be used.

Designation of a thick-walled bottom dish (2) of nominal size 120 mm, Type 1, Series A:

Petri bottom dish ISO 13132 – 120 × 20 – 1A – 2

Designation of a thick-walled top dish (1) of nominal size 120 mm, Type 1, Series A:

Petri top dish ISO 13132 – 120 × 20 – 1A – 1

## 6 Material

Petri dishes shall be manufactured from transparent glass of hydrolytic resistance Class HBG 1, Class HBG 2 or Class HGB 3 in accordance with ISO 719. The glass shall be reasonably free from residual strain and from defects which might impair safety, durability or appearance such as mould marks and waviness.

The glass shall not have any pronounced tint.

## 7 Dimensions

### 7.1 Series A Petri dishes

Series A Petri dishes shall comply with the dimensions specified in Table 1.

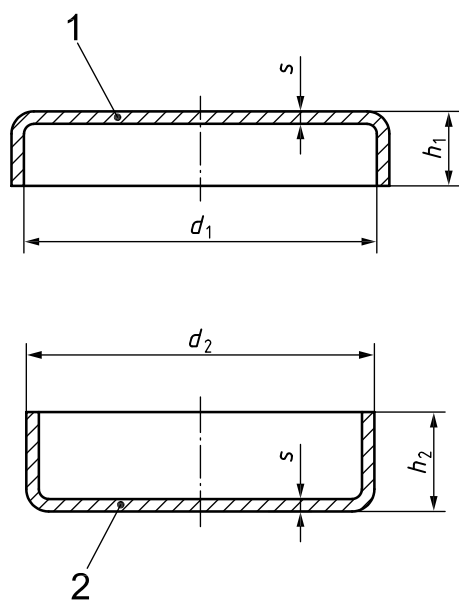

#### Key

- 1 top dish
- 2 bottom dish

Figure 1 — Thick-walled Petri dish

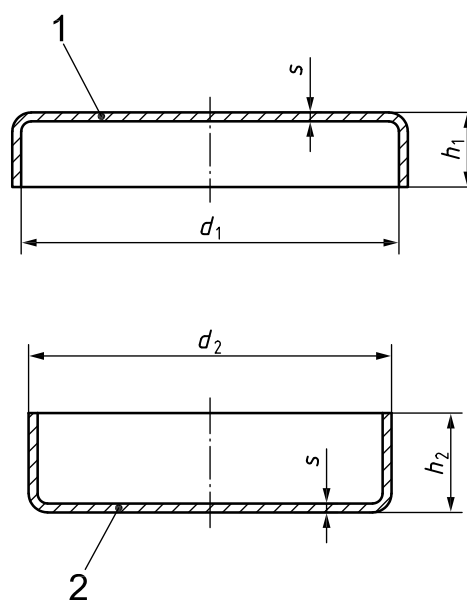

#### Key

- 1 top dish
- 2 bottom dish

Figure 2 — Thin-walled Petri dish



Table 1 — Dimensions for Series A Petri dishes

Dimensions in millimetres

Nominal size	Type 1 – Thick-walled (see Figure 1)					Type 2 – Thin-walled (see Figure 2)				
	$d_1$	$d_2$ 0 -1	$h_1$ $\pm 1$	$h_2$ $\pm 1$	$s$ $\approx$	$d_1$ $\pm 1$	$d_2$ $\pm 1$	$h_1$ $\pm 1,5$	$h_2$ $\pm 1,5$	$s$ $\pm 0,3$
50 × 12	—	—	—	—	—	47	45	9	14	1,3
60 × 20	$55^{+1,5}_0$	54	15	20	2,5	56	53	15	20	1,8
80 × 15	—	—	—	—	—	77	74	11	15	1,3
80 × 20	$71^{+1,5}_0$	70	15	20	2,5	76	73	15	20	1,8
100 × 15	$91^{+1,5}_0$	90	13	15	3	96	93	11,5	15	1,8
100 × 20				20					20	
120 × 20	$111^{+1,5}_0$	110	15	20	3,5	116	113	15	20	1,8
150 × 30	$140^{+2}_0$	139	15	30	4	146	142	18	27	1,8
200 × 30	—	—	—	—	—	197	193	23	29	1,6

## 7.2 Series B Petri dishes

Series B Petri dishes shall comply with the dimensions specified in Table 2. For any pair of Series B Petri dishes, the difference between the internal diameter of the top dish and external diameter of the bottom dish shall be between 2 mm to 4 mm.

Table 2 — Dimensions for Series B Petri dishes

Dimensions in millimetres

Nominal size	Type 2 – Thin-walled (see Figure 2)				
	$d_1$ $+1$ 0	$d_2$ 0 -1	$h_1$ 0 -1	$h_2$ $+1$ 0	$s$ min.
50 × 17	53	50	15	17	1,0
80 × 17	83	80	15	17	1,0
100 × 17	103	100	15	17	1,5
150 × 20	153	150	17	20	1,5
200 × 20	203	200	20	20	1,5

## 8 Construction

### 8.1 Basic requirements

Petri dishes shall be regular in shape (see e.g. Figure 1) and smoothly finished. They shall be symmetrical about the axis which shall be perpendicular to the plane of the base.

## 8.2 Base and side

The bases of both the bottom and top dishes shall be, as far as possible, in one plane surface and the sides shall be perpendicular to the base with a maximum deviation of 3°. The bases may be given a slight crown to prevent rocking.

## 8.3 Edge

The edges of the side wall of both bottom and top dishes shall be smoothly ground, fire-polished or clean pressed. The edges shall be in a plane parallel to their bases. If the edges are finished by burn-off process, there shall not be any tear-drop extending above the plane of cut-off in the bottom dish. In the top dish such protrusion up to 1 mm is permissible.

## 8.4 Flatness of bottom dishes

The inside depth at any two points on the base of the bottom dish shall not vary by more than 1,2 mm when measured in accordance with Annex A.

## 8.5 Performance requirements

Petri dishes shall not show visible decrease of transparency, opalescence, iridescence, frosting or cracks after testing by the following procedures:

- minimum 15 min wet sterilization at minimum 120 °C;
- minimum 1 h dry sterilization at minimum 160 °C.

## 9 Marking

Petri dishes shall be permanently and legibly marked on its sidewall with the following information:

- a) manufacturer's and/or supplier's name and/or trade mark;
- b) optionally the number of this International Standard, "ISO 13132".

## **Annex A** (normative)

### **Test method for flatness**

The following type test procedure applies for measurement of flatness of the inner surface of the Petri bottom dish.

- a) Affix a dial gauge to a stand.
- b) Place both the measuring equipment and the Petri dish under test on the same flat and firm surface.
- c) Lower the dial gauge in such a way that the pointer is pressed against the inner surface of the Petri dish so that some deflection is seen on the pointer.
- d) Then measure with the dial gauge the difference between the deepest and the highest point of the inner surface which should not exceed the value specified in 8.4.





# British Standards Institution (BSI)

BSI is the national body responsible for preparing British Standards and other standards-related publications, information and services.

BSI is incorporated by Royal Charter. British Standards and other standardization products are published by BSI Standards Limited.

## About us

We bring together business, industry, government, consumers, innovators and others to shape their combined experience and expertise into standards-based solutions.

The knowledge embodied in our standards has been carefully assembled in a dependable format and refined through our open consultation process. Organizations of all sizes and across all sectors choose standards to help them achieve their goals.

## Information on standards

We can provide you with the knowledge that your organization needs to succeed. Find out more about British Standards by visiting our website at [bsigroup.com/standards](http://bsigroup.com/standards) or contacting our Customer Services team or Knowledge Centre.

## Buying standards

You can buy and download PDF versions of BSI publications, including British and adopted European and international standards, through our website at [bsigroup.com/shop](http://bsigroup.com/shop), where hard copies can also be purchased.

If you need international and foreign standards from other Standards Development Organizations, hard copies can be ordered from our Customer Services team.

## Subscriptions

Our range of subscription services are designed to make using standards easier for you. For further information on our subscription products go to [bsigroup.com/subscriptions](http://bsigroup.com/subscriptions).

With **British Standards Online (BSOL)** you'll have instant access to over 55,000 British and adopted European and international standards from your desktop. It's available 24/7 and is refreshed daily so you'll always be up to date.

You can keep in touch with standards developments and receive substantial discounts on the purchase price of standards, both in single copy and subscription format, by becoming a **BSI Subscribing Member**.

**PLUS** is an updating service exclusive to BSI Subscribing Members. You will automatically receive the latest hard copy of your standards when they're revised or replaced.

To find out more about becoming a BSI Subscribing Member and the benefits of membership, please visit [bsigroup.com/shop](http://bsigroup.com/shop).

With a **Multi-User Network Licence (MUNL)** you are able to host standards publications on your intranet. Licences can cover as few or as many users as you wish. With updates supplied as soon as they're available, you can be sure your documentation is current. For further information, email [bsmusales@bsigroup.com](mailto:bsmusales@bsigroup.com).

## BSI Group Headquarters

389 Chiswick High Road London W4 4AL UK

## Revisions

Our British Standards and other publications are updated by amendment or revision.

We continually improve the quality of our products and services to benefit your business. If you find an inaccuracy or ambiguity within a British Standard or other BSI publication please inform the Knowledge Centre.

## Copyright

All the data, software and documentation set out in all British Standards and other BSI publications are the property of and copyrighted by BSI, or some person or entity that owns copyright in the information used (such as the international standardization bodies) and has formally licensed such information to BSI for commercial publication and use. Except as permitted under the Copyright, Designs and Patents Act 1988 no extract may be reproduced, stored in a retrieval system or transmitted in any form or by any means – electronic, photocopying, recording or otherwise – without prior written permission from BSI. Details and advice can be obtained from the Copyright & Licensing Department.

## Useful Contacts:

### Customer Services

**Tel:** +44 845 086 9001

**Email (orders):** [orders@bsigroup.com](mailto:orders@bsigroup.com)

**Email (enquiries):** [cservices@bsigroup.com](mailto:cservices@bsigroup.com)

### Subscriptions

**Tel:** +44 845 086 9001

**Email:** [subscriptions@bsigroup.com](mailto:subscriptions@bsigroup.com)

### Knowledge Centre

**Tel:** +44 20 8996 7004

**Email:** [knowledgecentre@bsigroup.com](mailto:knowledgecentre@bsigroup.com)

### Copyright & Licensing

**Tel:** +44 20 8996 7070

**Email:** [copyright@bsigroup.com](mailto:copyright@bsigroup.com)



...making excellence a habit.™