



BSI Standards Publication

**Paints and varnishes —
Electrochemical measurement
of the protection provided
to steel by paint coatings
— Current interrupter
(CI) technique, relaxation
voltammetry (RV) technique
and DC transient (DCT)
measurements**

NO COPYING WITHOUT BSI PERMISSION EXCEPT AS PERMITTED BY COPYRIGHT LAW

National foreword

This British Standard is the UK implementation of EN ISO 13129:2012.

The UK participation in its preparation was entrusted to Technical Committee STI/10, Test methods for paints.

A list of organizations represented on this committee can be obtained on request to its secretary.

This publication does not purport to include all the necessary provisions of a contract. Users are responsible for its correct application.

© The British Standards Institution 2013.

Published by BSI Standards Limited 2013

ISBN 978 0 580 67120 3

ICS 87.040

Compliance with a British Standard cannot confer immunity from legal obligations.

This British Standard was published under the authority of the Standards Policy and Strategy Committee on 28 February 2013.

Amendments issued since publication

Date	Text affected
------	---------------

EUROPEAN STANDARD

EN ISO 13129

NORME EUROPÉENNE

EUROPÄISCHE NORM

December 2012

ICS 87.040

English Version

Paints and varnishes - Electrochemical measurement of the protection provided to steel by paint coatings - Current interrupter (CI) technique, relaxation voltammetry (RV) technique and DC transient (DCT) measurements (ISO 13129:2012)

Peintures et vernis - Mesurage électrochimique de la protection apportée à l'acier par des revêtements de peinture - Technique du courant interrompu (CI), voltamétrie de relaxation (VR) ou mesurages de courants continus transitoires (CCT) (ISO 13129:2012)

Beschichtungsstoffe - Elektrochemische Messung der Schutzwirkung von Beschichtungen auf Stahl - Stromunterbrechungsverfahren (CI), Relaxationsvoltammetrie (RV) oder Gleichstromtransientenmessung (DCT) (ISO 13129:2012)

This European Standard was approved by CEN on 1 September 2012.

CEN members are bound to comply with the CEN/CENELEC Internal Regulations which stipulate the conditions for giving this European Standard the status of a national standard without any alteration. Up-to-date lists and bibliographical references concerning such national standards may be obtained on application to the CEN-CENELEC Management Centre or to any CEN member.

This European Standard exists in three official versions (English, French, German). A version in any other language made by translation under the responsibility of a CEN member into its own language and notified to the CEN-CENELEC Management Centre has the same status as the official versions.

CEN members are the national standards bodies of Austria, Belgium, Bulgaria, Croatia, Cyprus, Czech Republic, Denmark, Estonia, Finland, Former Yugoslav Republic of Macedonia, France, Germany, Greece, Hungary, Iceland, Ireland, Italy, Latvia, Lithuania, Luxembourg, Malta, Netherlands, Norway, Poland, Portugal, Romania, Slovakia, Slovenia, Spain, Sweden, Switzerland, Turkey and United Kingdom.



EUROPEAN COMMITTEE FOR STANDARDIZATION
COMITÉ EUROPÉEN DE NORMALISATION
EUROPÄISCHES KOMITEE FÜR NORMUNG

Management Centre: Avenue Marnix 17, B-1000 Brussels

Foreword

This document (EN ISO 13129:2012) has been prepared by Technical Committee ISO/TC 35 "Paints and varnishes" in collaboration with Technical Committee CEN/TC 139 "Paints and varnishes" the secretariat of which is held by DIN.

This European Standard shall be given the status of a national standard, either by publication of an identical text or by endorsement, at the latest by June 2013, and conflicting national standards shall be withdrawn at the latest by June 2013.

Attention is drawn to the possibility that some of the elements of this document may be the subject of patent rights. CEN [and/or CENELEC] shall not be held responsible for identifying any or all such patent rights.

According to the CEN/CENELEC Internal Regulations, the national standards organisations of the following countries are bound to implement this European Standard: Austria, Belgium, Bulgaria, Croatia, Cyprus, Czech Republic, Denmark, Estonia, Finland, Former Yugoslav Republic of Macedonia, France, Germany, Greece, Hungary, Iceland, Ireland, Italy, Latvia, Lithuania, Luxembourg, Malta, Netherlands, Norway, Poland, Portugal, Romania, Slovakia, Slovenia, Spain, Sweden, Switzerland, Turkey and the United Kingdom.

Endorsement notice

The text of ISO 13129:2012 has been approved by CEN as a EN ISO 13129:2012 without any modification.

INTERNATIONAL STANDARD

ISO 13129

First edition
2012-10-01

Paints and varnishes — Electrochemical measurement of the protection provided to steel by paint coatings — Current interrupter (CI) technique, relaxation voltammetry (RV) technique and DC transient (DCT) measurements

Peintures et vernis — Mesurage électrochimique de la protection apportée à l'acier par des revêtements de peinture — Technique du courant interrompu (CI), voltamétrie de relaxation (VR) et mesurages de courants continus transitoires (CCT)



Reference number
ISO 13129:2012(E)

© ISO 2012

Contents		Page
Foreword		iv
Introduction		v
1 Scope		1
2 Normative references		1
3 Terms and definitions		1
4 Apparatus		2
4.1 Faraday cage		2
4.2 Cell for sample, including electrode holder		2
4.3 Galvanostat		3
4.4 Potentiostat		3
4.5 Electrodes		3
4.6 Electrolyte		4
5 Specimens		4
5.1 Preconditioning of specimens		4
5.2 Environmental control		4
5.3 Evaluation of specimens exposed to weathering in the laboratory and in the field		4
5.4 Number of specimens and repeatability of results		5
6 Experimental procedure		5
6.1 General		5
6.2 Current interrupter technique		5
6.3 Relaxation voltammetry		6
6.4 DC transient measurements		7
7 Expression of results		8
8 Precision		8
9 Test report		8
Annex A (normative) Description of the dummy cell		10
Annex B (informative) Further considerations concerning measurements on coatings		12
Annex C (informative) Examples of results		14
Bibliography		15

Foreword

ISO (the International Organization for Standardization) is a worldwide federation of national standards bodies (ISO member bodies). The work of preparing International Standards is normally carried out through ISO technical committees. Each member body interested in a subject for which a technical committee has been established has the right to be represented on that committee. International organizations, governmental and non-governmental, in liaison with ISO, also take part in the work. ISO collaborates closely with the International Electrotechnical Commission (IEC) on all matters of electrotechnical standardization.

International Standards are drafted in accordance with the rules given in the ISO/IEC Directives, Part 2.

The main task of technical committees is to prepare International Standards. Draft International Standards adopted by the technical committees are circulated to the member bodies for voting. Publication as an International Standard requires approval by at least 75 % of the member bodies casting a vote.

Attention is drawn to the possibility that some of the elements of this document may be the subject of patent rights. ISO shall not be held responsible for identifying any or all such patent rights.

ISO 13129 was prepared by Technical Committee ISO/TC 35, *Paints and varnishes*, Subcommittee SC 9, *General test methods for paints and varnishes*.

Introduction

Quantitative assessment of protection performance of organic coatings has been required in industry, for example for evaluating the durability of organic coatings or judging the life of protective coatings. Electrochemical methods can be used for these purposes. The current interrupter (CI) technique, relaxation voltammetry (RV) and DC transient (DCT) measurements are simple techniques giving effective data which are comparable with electrochemical impedance spectroscopy (EIS) in principle.

An advantage is that the principle is simple and time for one measurement is short.

Paints and varnishes — Electrochemical measurement of the protection provided to steel by paint coatings — Current interrupter (CI) technique, relaxation voltammetry (RV) technique and DC transient (DCT) measurements

1 Scope

This International Standard specifies the procedure for evaluation of the experimental set-up of electrochemical measurements on high-impedance coated samples using methods that are based on the current interrupter (CI) technique, relaxation voltammetry (RV) or DC transient (DCT) measurements.

It provides specific definitions and guidance on optimizing the collection of CI, RV and DCT data from high-impedance systems. High impedance in the context of intact coatings refers to systems with an impedance greater than $10^9 \Omega/\text{cm}^2$. This does not preclude measurements on systems with lower impedance. This International Standard deals in particular with:

- instrumental set-up: requirements and shortcomings;
- data validation: checking the measurement range and the accuracy of the data;
- performing CI, RV, DCT measurements: specimen considerations and instrumental parameters;
- the experimental results: different methods of presenting CI, RV and DCT data.

Following the recommendations should ensure the acquisition of CI, RV and DCT data that can be used to study the performance of the specimen. This International Standard does not give guidelines for the interpretation of the data.

2 Normative references

The following referenced documents are indispensable for the application of this document. For dated references, only the edition cited applies. For undated references, the latest edition of the referenced document (including any amendments) applies.

ISO 16773-1, *Paints and varnishes — Electrochemical impedance spectroscopy (EIS) on high-impedance coated specimens — Part 1: Terms and definitions*

3 Terms and definitions

For the purposes of this document, the terms and definitions given in ISO 16773-1 and the following apply.

3.1

excitation

application of a voltage, U_{exc} , or current, I_{exc} , to force the system into a new state

3.2

current interrupter method

CI method

electrochemical technique which allows the relaxation potential of an electrochemical system to be recorded as a function of time just after the excitation current is interrupted and the potential decay curve obtained to be analysed

3.3
relaxation voltammetry

RV
electrochemical technique in which a potential is applied for a given excitation time and then the current is interrupted and just the potential is monitored as a function of time

3.4
DC transient measurement
DCT measurement

electrochemical technique in which a coated sample is charged such that the potential is shifted and then the sample is isolated and the potential is monitored against time while the potential returns to the open-circuit potential

3.5
potential/time decay curve

curve of potential, $U(t)$, plotted over time, while potential is changing after a defined excitation is removed

3.6
sampling rate

number of data points per time interval

3.7
time constant

product of resistor and capacitor values used in equivalent circuits, which has the dimensions of time

4 Apparatus

4.1 Faraday cage

The Faraday cage shall be constructed of metal sheet which reduces electromagnetic interference to the electrochemical cell (or circuit), and shall be connected to the instrument earth.

4.2 Cell for sample, including electrode holder

NOTE 1 Various types of measurement cell exist which are suitable for use with this International Standard. Most commonly used are two-electrode and three-electrode arrangements for measurements in an aqueous electrolyte.

The cell should be constructed of materials that will not corrode, otherwise deteriorate or contaminate the solution (e.g. PMMA, PTFE or glass). A material compatibility test should be carried out.

The cell shall be leak-proof to ensure that the geometrical surface of the specimen does not change with time.

The cell should preferably be designed to allow the following items to be inserted into the electrolyte chamber: the working electrode, the reference electrode, the counter-electrode.

Sometimes a thermometer (for temperature control) and gas inlet/outlet tubes to modify the oxygen content of the electrolyte are used. When using an inert gas, a gas scrubber should be used.

An example of an electrochemical cell is shown in Figure 1.

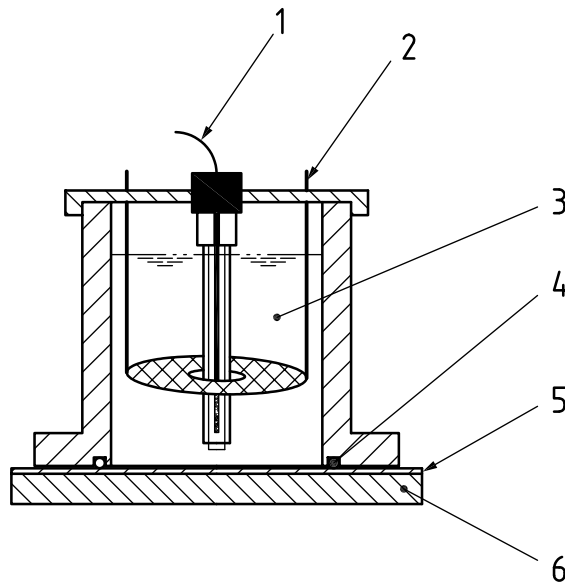

Key

- 1 reference electrode
- 2 counter-electrode
- 3 electrolyte
- 4 O-ring
- 5 coating
- 6 working electrode

Figure 1 — Example of an electrochemical cell

The components shown in Figure 1 are described in ISO 16773-2.

NOTE 2 This drawing does not imply that other designs are unsuitable.

4.3 Galvanostat

Use a galvanostat which applies a current with a rectangular pulse waveform and has a fall time no less than 10 times faster than that of the time constant of the sample.

4.4 Potentiostat

The potentiostat controls the potential of the working electrode with respect to the reference electrode. The potentiostat input impedance shall be high and the response time shall be fast.

4.5 Electrodes

4.5.1 Working electrode

Use as the working electrode a conductive substrate covered by the coating to be investigated. The exposed area should be accurately known, constant with time, and adequate for the investigation. A large area makes the measurement more sensitive for single defects (pores) and gives better signal-to-noise ratio.

4.5.2 Reference electrode

A low-impedance and low-noise reference electrode is recommended (a Luggin probe is not required). The potential of the reference electrode should be checked periodically to verify the accuracy of the electrode and its stability with time.

4.5.3 Counter-electrode

Use an inert conductor such as platinum with preferably a large surface area oriented parallel to the working electrode in order to ensure a homogeneous current distribution.

4.6 Electrolyte

The resistance of the solution should be low in comparison to the impedance of the system being investigated. Different types of electrolyte may be used. Non-aggressive electrolytes can be employed to characterize the properties of the system without introducing corrosion. An aggressive solution may be selected to characterize the corrosion resistance of the system. The electrolyte should be chosen with the end use of the coating in mind.

5 Specimens

5.1 Preconditioning of specimens

Proper preparation and preconditioning of coated specimens is critical for successful and reliable experimental data.

5.2 Environmental control

The coating should be applied and cured in accordance with the manufacturer's recommendations unless otherwise agreed upon between the interested parties. The film thickness should be as uniform as possible. The exact film thickness should be measured and reported (e.g. in accordance with ISO 2808). Temperature and humidity control during the application, curing, conditioning and measurement of organic coatings is crucial for a proper determination of the coating resistance.

The temperature of the specimens during measurements should be held constant to within ± 2 °C, preferably within ± 1 °C, at 23 °C, if not otherwise specified. Relative values for comparison between specimens outside these guidelines are acceptable if all the specimens are run under the same conditions. When the coating capacitance is the main parameter of interest, control of relative humidity during specimen conditioning is very important. To ensure reproducible conditioning, the humidity should be (50 ± 5) %, unless agreed otherwise.

For reliable measurements, temperature control should be equal to or better than ± 1 °C. For conditioning prior to measurement, an accuracy of ± 2 °C is sufficient for most cases. Each specimen should be kept under controlled conditions in order to prevent post-curing, degradation or any unintended irreversible modification of the coating.

5.3 Evaluation of specimens exposed to weathering in the laboratory and in the field

Measurements may be used to further characterize coating degradation during a weathering test. Specimens are measured after different elapsed times during the test and on completion of the test. Such weathering tests can be salt spray exposure in accordance with ISO 9227, exposure in a humidity chamber in accordance with ISO 6270-1, or cyclic tests. Other test methods are also used.

It might be advisable to use separate specimens at different elapsed times because a discontinuity in weathering could influence the results. When the coated specimens are removed from the test chamber for measurement, they typically go through a change in temperature and humidity. Some drying-out can occur if they are removed for more than a few minutes. Further, the coating is exposed to an electrolyte in the electrochemical cell, which can be different from the fluid in the test chamber. Therefore, special attention should be given to the precise procedure and timing when changing, removing and replacing specimens for measurement. The procedural details should be reported with the results.

If the measurement is done in an aggressive electrolyte (e.g. one containing an organic solvent), the exposure of the coating to the electrolyte may be considered as an additional component of the weathering test. In the case of cyclic weathering tests, measurements will depend upon the specific cycle the specimens are in. To allow comparison of measurements to reveal trends and changes, sequential measurements should be taken at the same time and in the same part of the cycle.

Stray currents can occur during measurements on a wet surface, even when the measured area is some distance from a scribe or other artificial defect. These stray currents can simulate a damaged coating, even if the coating is in excellent condition. Therefore, it is recommended that preventive measures, such as drying the non-measured area as completely as possible, be taken to avoid stray currents or other potential sources of error.

5.4 Number of specimens and repeatability of results

Coatings are materials with certain inherent properties: holidays, inhomogeneous film thickness, and non-uniform distribution of pigments, fillers and other constituents. It is therefore necessary to test more than one specimen. In most cases, a minimum of three replicate specimens is necessary for reliable results. It should be checked if the uniformity between the different specimen plates is sufficient. It is quite common to find repeatability better than 10 % between the capacitances of replicate specimens, but this depends on the type of coating and the conditions of measurement. More replicates might be necessary to overcome uniformity problems.

Such checks should be the responsibility of the operator and should also be agreed between the interested parties.

Specimens undergoing a rapid change, caused by weathering or other effects producing degradation, can show a larger fluctuation and therefore a lower repeatability.

Most measurement cells contain an electrolyte that is the medium between the coating and the counter-electrode. This means that the dominant process in the first 24 h is the absorption of electrolyte by the coating. To follow this process, the coating should be measured more frequently at the beginning. The exact interval between measurements will depend on the system.

The accuracy, reliability and repeatability of the experimental set-up should be determined on the dummy cells (see Annex A).

6 Experimental procedure

6.1 General

There are three choices for performing the measurement. The three methods are described in 6.2 to 6.4.

Before starting the test with real specimens, the experimental set-up shall be checked with five standard dummy cells (see Annex A).

In all cases and for all methods, electromagnetic interference or electrostatic charging will occur to some extent. It is highly recommended that the specimens be allowed to discharge completely after the Faraday cage has been closed. This requires a certain waiting time before the measurement can be started. In extreme cases, this waiting time can be 1 h or even more.

NOTE Further explanations can be found in Annex B.

6.2 Current interrupter technique

6.2.1 Measurement principle

A constant anodic current is applied for a certain period of time until an approximately constant voltage is reached, and then the current is switched off. After switching off, the decay of the potential is recorded. This potential/time curve is analysed using equivalent circuits.

6.2.2 Test of system operation with standard dummy cells

Start with dummy cell 1.

For details of the dummy cells, see Annex A. Connect the working electrode lead to one connection point on the dummy cell and the counter- and reference-electrode leads to the other. Place the dummy cell in a Faraday cage, ensuring that there is no electrical contact between the dummy cell and the conductive surfaces of the Faraday cage.

Run the experiment to cover the time range of interest (i.e. 10 s to 1 000 s) at a constant sampling time-interval (i.e. 100 μ s to 100 ms). First, measure the open-circuit potential. For a dummy cell, this should be 0 V. Then apply a rectangular-waveform current of 1 pA to 100 000 pA to the dummy cell, gradually increasing it until the potential deviation at saturation becomes 10 mV to 50 mV. If the potential saturation is not enough, increase the time during which the current is applied. Then, the current is interrupted just at the end of the rectangular waveform. Potential relaxation starts. Record the potential/time decay curve.

The sampling rate should be high enough to determine the time constant(s) of the dummy cell(s). If necessary, increase the sampling rate to improve the accuracy of the determination.

Evaluate the decay curve by fitting it to the model used for the dummy cell. Compare the values thus obtained with the original values for the dummy cell. If necessary, adjust the measurement parameters, i.e. increase excitation current and time, in order to match the chosen (or known) values.

Repeat this procedure with the other four dummy cells.

6.2.3 Specimen measurement

Put the specimen in the cell. Connect the specimen to the working-electrode lead. Add the electrolyte. Attach the counter-electrode (and, if necessary, the reference electrode) to the cell and wait until steady-state conditions are achieved. Start the measurement as described above for the dummy cells.

The recorded decay curve will then be analysed.

NOTE Examples of results are shown in Annex C.

6.3 Relaxation voltammetry

6.3.1 Measurement principle

The potential $+U_{\text{exc}}$ is superimposed anodically on the open-circuit potential (OCP) and causes a transient current which tends to a constant value after a certain time. After the current has become constant, the current is measured and the cell is switched off. The ensuing potential decay $U(t)$ is recorded as a function of time. After the potential has reached approximately the value of the OCP, the procedure is repeated, using the same excitation potential, in the cathodic direction. For the evaluation of the transient response $U(t)$, the average value of these two half-cycles is taken.

NOTE This "symmetrical" operation is important, considering the experimental fact, demonstrated by measurements on barrier coatings, that the transients will not return exactly to the value of the OCP observed before the excitation. In a continuous mode of operation, this would result in an irreversible shift of the OCP. This would lead to erroneous results due to a superimposed relaxation caused by the offset between the "end-potential" and the true OCP.

To overcome the problem of an unintended potential shift, the next starting OCP is taken as the average of the last value of the actual measured transient and for the preceding half-cycle.

6.3.2 Dummy cells

For details of the dummy cells, see Annex A.

Start with dummy cell 1.

Connect the working-electrode lead to one end of the dummy cell and the counter- and reference-electrode leads to the other end of the dummy cell. Place the dummy cell in a Faraday cage, ensuring that there is no electrical contact between the dummy cell and the conductive surfaces of the Faraday cage.

First, measure the open-circuit potential. For a dummy cell, this should be 0 V. Apply a potential U_{exc} of 20 mV for 2 min in each direction. Record each potential/time decay curve for 2 min.

The sampling rate should be high enough to determine the time constant of the dummy cell. If necessary, increase the sampling rate to improve the accuracy of the determination.

Average the two decay curves and evaluate the averaged curve by fitting it to the model used for the dummy cell. Compare the values thus obtained with the original values for the components of the dummy cell. If necessary, adjust the measurement parameters, i.e. increase, U_{exc} and time.

Repeat this procedure with the other four dummy cells.

6.3.3 Specimen measurement

Put the specimen in the cell. Connect the specimen to the working-electrode lead. Add the electrolyte. Attach the counter-electrode (and, if necessary, the reference electrode) to the cell. Start the measurement as described above for the dummy cells.

The averaged decay curve is then analysed.

6.4 DC transient measurements

6.4.1 Measurement principle

The measurement equipment consists of two halves:

- In one half, a voltmeter capable of measuring the potential between the specimen and the reference electrode to an accuracy of at least 0,1 mV at intervals of about 10 ms and with a very high input impedance ($> 10 \text{ G}\Omega$) (or a suitable fast data logger and a high-impedance buffer amplifier) is used to record transients. It can be useful to have a facility to “back off” the initial cell potential if a sensitive scale needs to be used.
- The other half comprises a variable-voltage source (e.g. a battery or potentiostat) to polarize the cell, a sensitive current meter to measure the steady-state current, and a relay, used to initiate the transient — all connected in series.

The procedure is to measure the OCP, adjust U_{exc} to values about 20 mV to 50 mV higher or lower than the OCP and then apply it across the cell. Before the excitation time, t_{exc} , has elapsed, the steady-state current and potential are recorded, then the voltage source is disconnected from the cell and the resultant transient $U(t)$ is recorded until the potential returns to the original OCP value. The transient is then further analysed, e.g. by fitting to one or more exponential functions.

If, because of diffusion effects, no steady-state potential is reached, a plot of $U(t)$ versus the square root of time may be used as a base-line to allow for such effects.

6.4.2 Dummy cells

For details of the dummy cells, see Annex A.

Start with dummy cell 1.

Connect the working-electrode lead to one end of the dummy cell and the counter- and reference-electrode leads to the other end of the dummy cell. Place the dummy cell in a Faraday cage, ensuring that there is no electrical contact between the dummy cell and the conductive surfaces of the Faraday cage.

First, measure the open-circuit potential. For a dummy cell, this should be 0 V. Apply a potential U_{exc} of 20 mV for 2 min in each direction. Record each potential/time decay curve for 2 min.

The sampling rate should be high enough to determine the time constant of the dummy cell. If necessary, increase the sampling rate to improve the accuracy of the determination.

Average the absolute values represented by the two decay curves and evaluate the averaged curve by fitting it to the model used for the dummy cell. Compare the values thus obtained with the original values for the components of the dummy cell. If necessary, adjust the measurement parameters, i.e. increase, U_{exc} and time.

Repeat this procedure with the other four dummy cells.

6.4.3 Sample measurement

Put the specimen and the reference electrode in the cell. Connect the specimen to the working-electrode lead and the reference electrode to the reference-electrode lead of the high-impedance voltmeter. Add the electrolyte. Attach the counter-electrode to the potentiostat and ammeter in series. Start the measurement as described above for the dummy cells.

The recorded decay curve is then analysed.

7 Expression of results

Calculate the total DC resistance, R_{DC} , from Equation (1):

$$R_{DC} = \frac{U_{exc}}{I_{exc}} \quad (1)$$

A logarithmic plot of the transient curves versus time is recommended. It can be useful to normalize the transient curves.

For further data analysis, it might be helpful to fit the data measured to one or more exponentials. A plot of $\log U$ versus t is recommended.

NOTE The data representation by curve fitting to sums of exponentials does not imply a mechanistic interpretation.

8 Precision

No precision data are available at the moment.

9 Test report

The test report shall contain at least the following information:

- a) all details necessary to identify the product tested;
- b) a reference to this International Standard (ISO 13129:2012);
- c) details of the preparation of the test specimens, including:
 - 1) the material (including thickness) and surface preparation of the substrate,
 - 2) the method of application of the coating under test to the substrate, including the duration and conditions of drying between coats in the case of a multi-coat system,
 - 3) the duration and conditions of drying (or stoving) of the coat, and the conditions of ageing, if applicable, before testing,
 - 4) the thickness, in micrometres, of the dry coating and the method of measurement (e.g. from ISO 2808) used, and whether it is a single coating or a multi-coat system;
- d) the temperature and relative humidity during conditioning and testing, if different from those recommended in 5.2;
- e) the electrolyte details, i.e. type of salt, concentration and additives;
- f) the test method used, including the excitation conditions, waiting times and test duration;
- g) the results of the test, as indicated in Clause 7;
- h) any deviations from the procedure specified;
- i) any unusual features (anomalies) observed during the test;

j) the date of the test.

Annex A (normative)

Description of the dummy cell

A.1 General

A set of five equivalent circuits (dummy cells) is used to check the overall experimental arrangement for investigations of high-impedance coatings. These dummy cells are mounted in separate boxes. The specific electrical components of these five cells are given in Table A.1.

A.2 Components of the dummy cells

Each dummy cell consists of a combination of resistors and capacitors which are soldered directly onto a printed-circuit board (see Figure A.1). Such networks of resistors and capacitors (equivalent circuits) are often used in work on high-impedance coated specimens.

NOTE Because of the very high overall resistance of equivalent circuits A and B, the resistor simulating the electrolyte can be neglected. Typically, the values of resistances R_1 and R_2 are above 100 M Ω , whereas the electrolyte resistance is around 100 Ω to 500 Ω . As a consequence, the electrolyte resistance is not significant in this kind of application.

The values of the components of the five dummy cells are chosen in accordance with the following considerations:

- Dummy cell 1 should check the input resistance as well as the input capacitance of the measurement equipment.
- Dummy cells 2 to 5 should check the capability of the evaluation software and the impedance measurement equipment to distinguish between only slightly different resistor/capacitor combinations.

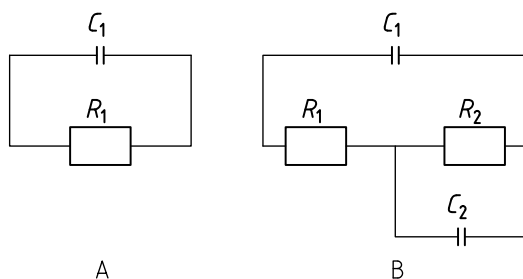

Figure A.1 — Equivalent circuits A and B of the dummy cells

Table A.1 — Values of the components of the dummy cells

Dummy cell	Circuit	R_1 $\times 10^9 \Omega$	R_2 $\times 10^9 \Omega$	C_1 $\times 10^{-9} \text{ F}$	C_2 $\times 10^{-9} \text{ F}$
1	A	50	—	0,15	—
2	B	1	10	0,15	0,47
3	B	1	0,2	0,1	20
4	B	1	1	1	100
5	B	5	7,5	0,12	0,42

A.3 Accuracy requirements for the components

The accuracy required for resistors below $10^9 \Omega$ is $\pm 2 \%$ and for resistors above $10^9 \Omega$ it is $\pm 5 \%$. The accuracy required for the capacitors is $\pm 5 \%$. Such resistors and capacitors are available commercially.

A.4 Circuit description

Usually, the measurement of high-impedance coatings requires only a two-electrode set-up, but electrochemical workstations offer the possibility of connecting up three or four electrodes. To simplify the connection of the dummy cells to electrochemical workstations, each cell should have three terminals (as indicated in Figure A.2), the two metallic connectors being designed for easy connection to wires. The third terminal is connected to the Faraday cage.

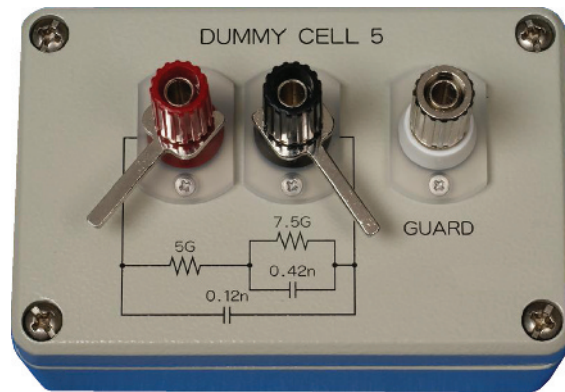

Figure A.2 — Photograph of a dummy cell

Annex B (informative)

Further considerations concerning measurements on coatings

If, as in Figure B.1a), two time constants clearly occur, it is recommended that the later time constant be analysed first and subtracted from the entire curve, and that the first time constant then be analysed by linear regression. If the values of the time constants become closer, the separation will become more difficult [see Figure B.1b)]. In extreme cases only a single time constant might result.

NOTE It is also possible to fit U versus t using an exponential, subtract it from the original transient and replot it on a logarithmic scale, or to fit using two exponentials by the non-linear least-squares method.

Any distortions, e.g. arising from the switch, can lead to misinterpretation. In order to check for such parasitic effects, a repeated excitation with opposite sign can reveal differences between the anodic and cathodic decay curves. However, by averaging the absolute values represented by the anodic and the cathodic decay curve, these distortions can be smoothed out.

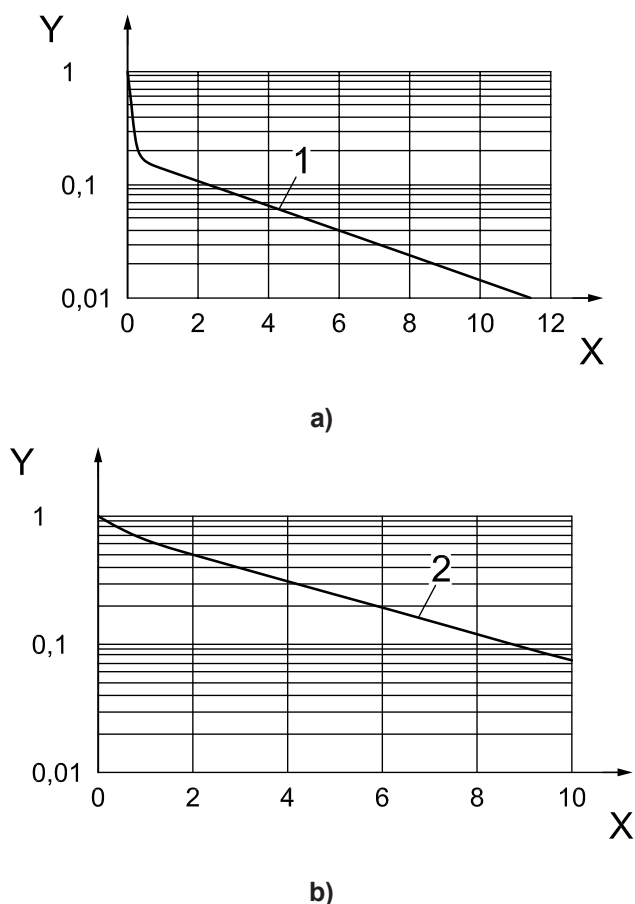

Key

- Y log(normalized potential, U)
- X measurement time, t , in seconds
- 1 decay curve for dummy cell 3
- 2 decay curve for dummy cell 4

Figure B.1 — Logarithmic plots of $U(t)$ as a function of measurement time

In time-domain techniques, the excitation time is one of the most important parameters and therefore has to be selected carefully. In Figure B.2, the influence of the excitation time on the excitation current prior to switching off the excitation is shown. It can be seen that, with increasing excitation time, the excitation current becomes smaller and approaches an asymptotic value.

A similar effect appears in the transient curves shown in Figure B.3. It should be concluded that in the case of incomplete excitation misleading results might occur.

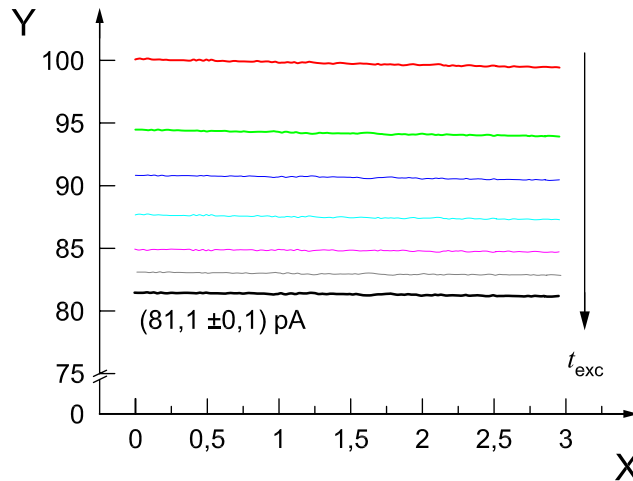

Key

- X time, t , in seconds
- Y current, I , in picoamperes
- t_{exc} excitation time

Figure B.2 — Excitation current plotted against time before switching off the excitation for different excitation times, measured by relaxation voltammetry

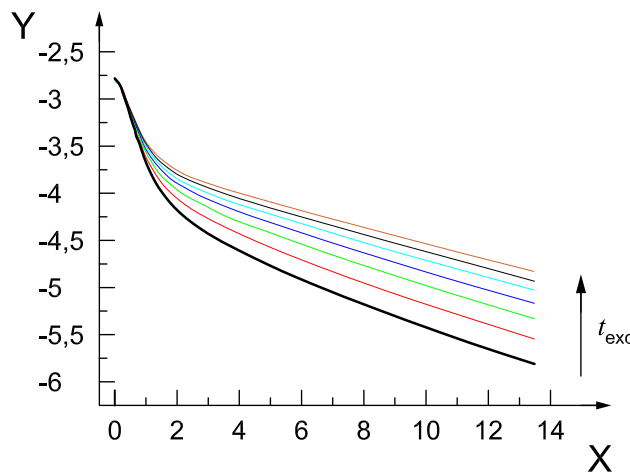

Key

- X square root of time, in seconds
- Y $\log(\text{potential}, U, \text{ in millivolts})$
- t_{exc} excitation time

Figure B.3 — Normalized potential-decay curves plotted logarithmically against the square root of time for different excitation times

Annex C (informative)

Examples of results

Figure C.1 shows an example of plots of the polarization resistance of an alkyd coating on a steel substrate against time, produced using the current interrupter technique, for coatings of different thicknesses.

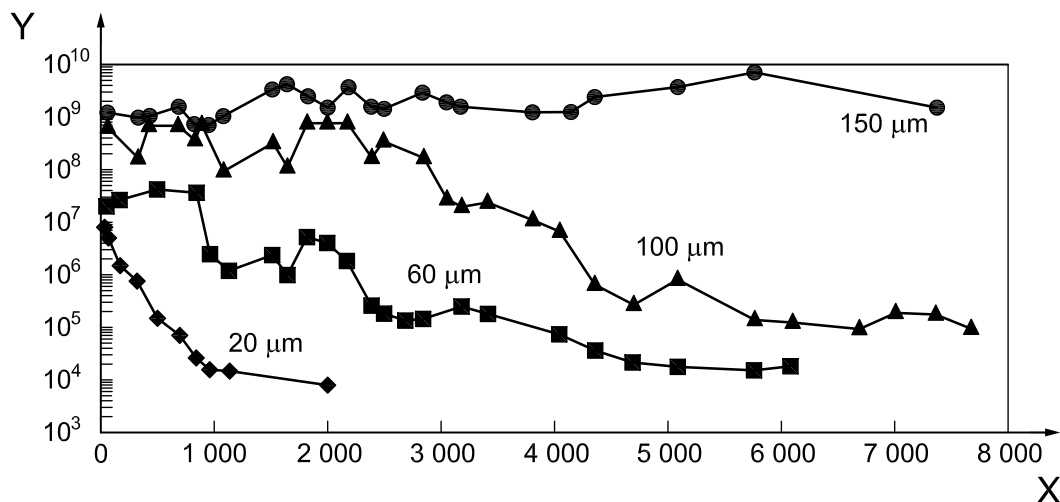

Key

- X immersion time, in hours
- Y polarization resistance, in ohm square centimetres ($\Omega\text{-cm}^2$)

Figure C.1 — Change in polarization resistance after immersion in 3 % NaCl

Figure C.2 shows an example of plots of the resistance of an alkyd coating on a steel substrate against time, produced using the current interrupter technique, for coatings of different thicknesses.

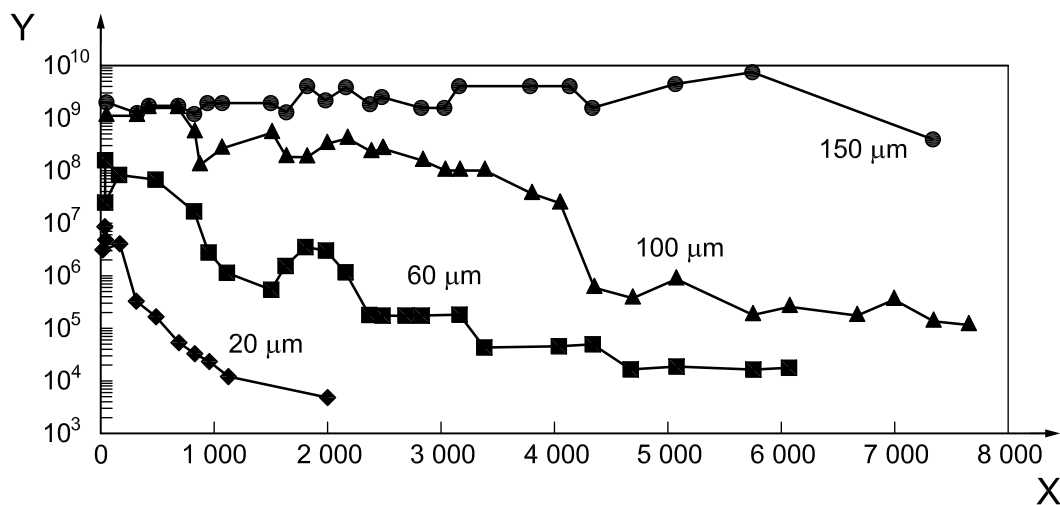

Key

- X immersion time, in hours
- Y resistance of coating, in ohm square centimetres ($\Omega\text{-cm}^2$)

Figure C.2 — Change in film resistance after immersion in 3 % NaCl

Bibliography

- [1] ISO 2808, *Paints and varnishes — Determination of film thickness*
- [2] ISO 6270-1, *Paints and varnishes — Determination of resistance to humidity — Part 1: Continuous condensation*
- [3] ISO 9227, *Corrosion tests in artificial atmospheres — Salt spray tests*
- [4] ISO 16773-2, *Paints and varnishes — Electrochemical impedance spectroscopy (EIS) on high-impedance coated specimens — Part 2: Collection of data*
- [5] H. Tanabe, T. Shinohara, M. Hoshino and Y. Sato; Application of Current Interrupter Method on the Estimation of Protective Coatings, Proceedings of INTERFINISH 80, p. 339-343 (1980) International Union for Surface Finishing (IUSF)
- [6] I.Sekine, M.Yuasa, K.Tanaka, T.Tsutsumi, F.Koizumi, N.Oda, H.Tanabe and M.Nagai; Relation of parameters obtained by various electrochemical measurements for evaluation of abilities of protective coating films, J.Japan Soc. Colour Material 67, 424-430 (1994)
- [7] H.Tanabe, M. Nagai, H. Matsuno, M. Kano; Evaluation of protective coating by a current interrupter technique, Advances in Corrosion Protection by Organic Coatings II, The Electrochemical Society, Proceedings Volume 95-13, p.181-192 (1995)
- [8] I. Sekine; Recent evaluation of corrosion protective paint films by electrochemical methods, Progress in Organic Coatings 31, 73-80 (1997)
- [9] M.Nagai, T.Taki, H.Tanabe and M.Kano; Anti corrosive properties of water-borne paint using electrochemical technique, "Advances in Corrosion Protection by Organic Coatings III, (Eds. I.Sekine, M.Kendig, D.Scantlebury and D.Mills), The Electrochemical Society, Proceedings Volume 97-41, p.199-205 (1998)
- [10] J. Vogelsang, W. Strunz *New interpretation of electrochemical data obtained from organic barrier coatings*, Electrochim. Acta 46 (2001) 3817
- [11] G. Meyer, H. Ochs, W. Strunz, J. Vogelsang; 'Barrier coatings with high Ohmic resistance — comparison between Relaxation Voltammetry and Impedance Spectroscopy'; Proceed. of EMCR 1997, 25. - 29. -8. 1997, Trento Italy
- [12] H. Ochs, W. Strunz, J. Vogelsang; Relaxation voltammetry with organic barrier coatings on steel — experimental and theoretical approach; Proceed. of EMCR 1997, Trento, Italy
- [13] W. Strunz, J. Vogelsang; Characterization and evaluation of organic coatings using relaxation voltammetry; Proceed. of EUROCORR 1998, Utrecht, Netherlands
- [14] J. Vogelsang, W. Strunz; Barrier coatings — a challenge for EIS and RV; Proceed. of EIS 1998, Rio de Janeiro (Brasil)
- [15] W. Strunz; *The frequency behavior of the 'two-step' continuous time random walk*; Proceed. of EMCR 2000, Budapest, Hungary
- [16] H. Ochs, J. Vogelsang *Effect of temperature cycles on impedance spectra of barrier coatings under immersion conditions*, Electrochim. Acta 49 (2004) 2973
- [17] W. Strunz, C. A. Schiller, J. Vogelsang; The evaluation of experimental dielectric data of barrier coatings in frequency- and time domain, Electrochim. Acta 51 (2006) 1437
- [18] H.E.M. Smith and J.M. Sykes, Electrochemical measurements of corrosion beneath coatings, 10th International Congress on Metallic Corrosion, Madras, India, 1987, p1213
- [19] J.M. Sykes, Electrochemical measurements on organic coatings, Proceedings UK Corrosion '87, p359 (1987)

- [20] J.M. Sykes and H.E.M. Smith, Electrochemical measurements on polymer coated metal using a potential decay technique, Materials Science Forum 44&45 (1989), 433 [Proceedings of the 3rd International Symposium on Electrochemical Methods in Corrosion Research, Zurich 1988]
- [21] H.E.M. Smith and J.M. Sykes, Electrochemical measurements of corrosion beneath coatings, 10th International Congress on Metallic Corrosion, Madras, India, 1987, p1213
- [22] J.M. Sykes, Electrochemical measurements on organic coatings, Proceedings UK Corrosion '87, p359 (1987)
- [23] J.M. Sykes and H.E.M. Smith, Electrochemical measurements on polymer coated metal using a potential decay technique, Materials Science Forum 44&45 (1989), 433 (Proceedings of the 3rd International Symposium on Electrochemical Methods in Corrosion Research, Zurich 1988)
- [24] J.D.B. Sharman, H.E.M. Smith and J.M. Sykes, Impedance of polymer coatings and polymer-coated steel measured by a potential decay technique — Advances in corrosion protection by organic coatings (Eds. M. Kendig and J.D. Scantlebury), Electrochem. Soc. 1989

British Standards Institution (BSI)

BSI is the independent national body responsible for preparing British Standards and other standards-related publications, information and services. It presents the UK view on standards in Europe and at the international level.

BSI is incorporated by Royal Charter. British Standards and other standardisation products are published by BSI Standards Limited.

Revisions

British Standards and PASs are periodically updated by amendment or revision. Users of British Standards and PASs should make sure that they possess the latest amendments or editions.

It is the constant aim of BSI to improve the quality of our products and services. We would be grateful if anyone finding an inaccuracy or ambiguity while using British Standards would inform the Secretary of the technical committee responsible, the identity of which can be found on the inside front cover. Similar for PASs, please notify BSI Customer Services.

Tel: +44 (0)20 8996 9001 Fax: +44 (0)20 8996 7001

BSI offers BSI Subscribing Members an individual updating service called PLUS which ensures that subscribers automatically receive the latest editions of British Standards and PASs.

Tel: +44 (0)20 8996 7669 Fax: +44 (0)20 8996 7001

Email: plus@bsigroup.com

Buying standards

You may buy PDF and hard copy versions of standards directly using a credit card from the BSI Shop on the website www.bsigroup.com/shop. In addition all orders for BSI, international and foreign standards publications can be addressed to BSI Customer Services.

Tel: +44 (0)20 8996 9001 Fax: +44 (0)20 8996 7001

Email: orders@bsigroup.com

In response to orders for international standards, BSI will supply the British Standard implementation of the relevant international standard, unless otherwise requested.

Information on standards

BSI provides a wide range of information on national, European and international standards through its Knowledge Centre.

Tel: +44 (0)20 8996 7004 Fax: +44 (0)20 8996 7005

Email: knowledgecentre@bsigroup.com

BSI Subscribing Members are kept up to date with standards developments and receive substantial discounts on the purchase price of standards. For details of these and other benefits contact Membership Administration.

Tel: +44 (0)20 8996 7002 Fax: +44 (0)20 8996 7001

Email: membership@bsigroup.com

Information regarding online access to British Standards and PASs via British Standards Online can be found at www.bsigroup.com/BSOL

Further information about British Standards is available on the BSI website at www.bsi-group.com/standards

Copyright

All the data, software and documentation set out in all British Standards and other BSI publications are the property of and copyrighted by BSI, or some person or entity that own copyright in the information used (such as the international standardisation bodies) has formally licensed such information to BSI for commercial publication and use. Except as permitted under the Copyright, Designs and Patents Act 1988 no extract may be reproduced, stored in a retrieval system or transmitted in any form or by any means – electronic, photocopying, recording or otherwise – without prior written permission from BSI. This does not preclude the free use, in the course of implementing the standard, of necessary details such as symbols, and size, type or grade designations. If these details are to be used for any other purpose than implementation then the prior written permission of BSI must be obtained. Details and advice can be obtained from the Copyright & Licensing Department.

Tel: +44 (0)20 8996 7070

Email: copyright@bsigroup.com

BSI

389 Chiswick High Road London W4 4AL UK

Tel +44 (0)20 8996 9001

Fax +44 (0)20 8996 7001

www.bsigroup.com/standards