

BS EN ISO 13127:2012

Incorporating corrigendum December 2012



BSI Standards Publication

Packaging — Child resistant packaging — Mechanical test methods for reclosable child resistant packaging systems

bsi.

...making excellence a habit.™

National foreword

This British Standard is the UK implementation of EN ISO 13127:2012. It is identical to ISO 13127:2012, incorporating corrigendum December 2012.

The UK participation in its preparation was entrusted by Technical Committee PKW/0, Packaging, to Subcommittee PKW/0/3, Child Resistant Packaging.

A list of organizations represented on this subcommittee can be obtained on request to its secretary.

This publication does not purport to include all the necessary provisions of a contract. Users are responsible for its correct application.

© The British Standards Institution 2013.

Published by BSI Standards Limited 2013.

ISBN 978 0 580 81353 5

ICS 55.020

Compliance with a British Standard cannot confer immunity from legal obligations.

This British Standard was published under the authority of the Standards Policy and Strategy Committee on 28 February 2013.

Amendments/corrigenda issued since publication

Date	Text affected
------	---------------

EUROPEAN STANDARD

EN ISO 13127

NORME EUROPÉENNE

EUROPÄISCHE NORM

October 2012

ICS 55.020

English Version

**Packaging - Child resistant packaging - Mechanical test
methods for reclosable child resistant packaging systems (ISO
13127:2012)**

Emballages - Emballages à l'épreuve des enfants -
Méthodes d'essais mécaniques pour systèmes d'emballage
refermables à l'épreuve des enfants (ISO 13127:2012)

Verpackung - Kindergesicherte Verpackung - Mechanische
Prüfverfahren für wiederverschließbare kindergesicherte
Verpackungssysteme (ISO 13127:2012)

This European Standard was approved by CEN on 30 September 2012.

CEN members are bound to comply with the CEN/CENELEC Internal Regulations which stipulate the conditions for giving this European Standard the status of a national standard without any alteration. Up-to-date lists and bibliographical references concerning such national standards may be obtained on application to the CEN-CENELEC Management Centre or to any CEN member.

This European Standard exists in three official versions (English, French, German). A version in any other language made by translation under the responsibility of a CEN member into its own language and notified to the CEN-CENELEC Management Centre has the same status as the official versions.

CEN members are the national standards bodies of Austria, Belgium, Bulgaria, Croatia, Cyprus, Czech Republic, Denmark, Estonia, Finland, Former Yugoslav Republic of Macedonia, France, Germany, Greece, Hungary, Iceland, Ireland, Italy, Latvia, Lithuania, Luxembourg, Malta, Netherlands, Norway, Poland, Portugal, Romania, Slovakia, Slovenia, Spain, Sweden, Switzerland, Turkey and United Kingdom.



EUROPEAN COMMITTEE FOR STANDARDIZATION
COMITÉ EUROPÉEN DE NORMALISATION
EUROPÄISCHES KOMITEE FÜR NORMUNG

Management Centre: Avenue Marnix 17, B-1000 Brussels

Foreword

This document (EN ISO 13127:2012) has been prepared by Technical Committee CEN/TC 261 "Packaging", the secretariat of which is held by AFNOR, in collaboration with Technical Committee ISO/TC 122 "Packaging".

This European Standard shall be given the status of a national standard, either by publication of an identical text or by endorsement, at the latest by April 2013, and conflicting national standards shall be withdrawn at the latest by April 2013.

Attention is drawn to the possibility that some of the elements of this document may be the subject of patent rights. CEN [and/or CENELEC] shall not be held responsible for identifying any or all such patent rights.

According to the CEN/CENELEC Internal Regulations, the national standards organisations of the following countries are bound to implement this European Standard: Austria, Belgium, Bulgaria, Croatia, Cyprus, Czech Republic, Denmark, Estonia, Finland, Former Yugoslav Republic of Macedonia, France, Germany, Greece, Hungary, Iceland, Ireland, Italy, Latvia, Lithuania, Luxembourg, Malta, Netherlands, Norway, Poland, Portugal, Romania, Slovakia, Slovenia, Spain, Sweden, Switzerland, Turkey and the United Kingdom.

Contents

Page

Introduction	iv
1 Scope	1
2 Normative references	1
3 Terms and definitions	1
4 General requirements	2
4.1 Rationale	2
4.2 Reference data	2
4.3 Package modifications	2
4.4 Testing facilities	4
4.5 Test methods	5
4.6 Test method selection	5
4.7 Component verification	5
5 Samples	5
5.1 Sample selection	5
5.2 Sample preparation	5
6 Testing	5
6.1 Applicability of tests	5
6.2 Specific tests	6
6.3 Assessment of test results	6
7 Test report	6
7.1 General	6
7.2 Test facility (name and address)	6
7.3 Applicant (name and address)	6
7.4 Report number	7
7.5 Date	7
7.6 Manufacturer	7
7.7 Packaging description	7
7.8 References	7
7.9 Test description and results	7
7.10 Signature	7
Annex A (normative) Torque release test	8
Annex B (normative) Squeeze test	9
Annex C (normative) Non-squeeze torque test	10
Annex D (normative) Press down and turn engagement test	11
Annex E (normative) Push and turn test	12
Annex F (normative) Reverse ratchet torque test	13
Annex G (normative) Disassembly test	14
Annex H (normative) Rotational torque test	17
Annex I (normative) Push-off force	18
Annex J (normative) Application force	19
Bibliography	20

Introduction

A significant number of suspected cases of ingestion by children of products used about the home is reported to the medical profession each year. Most are not serious and those that are associated with more serious side effects involve products known to be hazardous, e.g. certain medicinal products, liquid fuels and solvents, strongly acid or alkaline preparations and some garden products. Most commonly used household detergents, cleaning agents and maintenance and care products are not known to have caused injury. However, whether ingestion (actual or suspected) causes injuries or not, such incidents can have traumatic effects on both the child and its parents.

The use of potentially hazardous agents in certain products is necessary to achieve effectiveness; consequently steps have to be taken to limit the occurrence of accidents. One approach has been to try to increase general awareness of hazards associated with various products. Nevertheless, proper labelling and information by the manufacturer is important for the safe use of products in the home.

Another approach has been the use of child resistant packaging to put a physical barrier between the child and the hazardous product. Such packaging should only be used for products as mentioned above since, if used in other circumstances, it could lead to confusion among consumers. It is important to recognize that it is unrealistic to expect that any functional packaging can be totally impossible for a child to open and this type of packaging cannot be a substitute for normal safety precautions. The packaging functions as a last defence if other barriers separating children and hazardous products have failed. Hence, the overall responsibility rests with the parents or other responsible adults.

The aim of this International Standard is to establish mechanical test methods to safeguard child resistance properties of the packaging system.

According to ISO 8317, the panel test is intended for initial type approval but it does not sufficiently cover change management.

NOTE Change management covers, but is not limited to, for example, change of supplier, packaging material, component manufacturing site, material brand or scale up.

Those changes need to be assessed using risk management procedures. Mechanical test methods deliver scientific data which introduce a more scientific means of ensuring compliance with the originally type tested package. The test results are essential for an appropriate risk assessment.

The object of this International Standard is to permit the comparison, by mechanical testing, of the physical parameters of the packaging system under test with those of the individual units tested for certification purposes. It is the responsibility of the component manufacturer to provide access to test methods and test data to the customer.

Packaging — Child resistant packaging — Mechanical test methods for reclosable child resistant packaging systems

1 Scope

This International Standard specifies test methods for mechanical testing of reclosable child resistant packaging. The data generated by these mechanical test methods are suitable for comparing child resistant characteristics of related reclosable packaging systems.

This International Standard is not intended for routine quality assurance purposes.

NOTE The use of children and adults for testing in accordance with ISO 8317 is an essential feature of that standard.

2 Normative references

The following referenced documents are indispensable for the application of this document. For dated references, only the edition cited applies. For undated references, the latest edition of the referenced document (including any amendments) applies.

ISO 8317, *Child-resistant packaging — Requirements and testing procedures for reclosable packages*

3 Terms and definitions

For the purposes of this document, the terms and definitions given in ISO 8317 and the following apply.

3.1

mechanical testing

documented and reproducible methods intended to measure the resistance of the relevant features of a child resistant packaging system

3.2

essential characteristics

those elements of the container/closure system that are critical for maintaining the child resistant functionality

NOTE See 4.3 for examples of essential characteristics.

3.3

thread system

child resistant packaging system having a combination of container and closure that is reliant on having compatible threads in order to maintain the child resistance functions and sealing integrity

3.4

squeeze and turn system

child resistant packaging system which requires the user to squeeze the closure at designated points while simultaneously applying a torque to unscrew the closure from the container

3.5

push and turn system

press and turn system

child resistant packaging system which requires the user to apply a downward force while simultaneously applying a torque to unscrew the closure from the container

3.6
snap-cap system
align and lift system

child resistant packaging system which requires the user to align marks on the container and closure before pushing off the closure

3.7
liner

medium used to form a seal between a closure and a container

3.8
original specification

full description of all components of the test specimens, including reference to number and issue of drawings, dimensions, tolerances and material specification for all components

NOTE Components include, but are not limited to, closures, liners or containers.

3.9
reference data

data generated from type-approved child resistant packages using the testing methods specific to the packaging type as given in this International Standard

NOTE Reference data provide the link between packages tested and found to be compliant with ISO 8317 and the packages to be tested according to this International Standard.

4 General requirements

4.1 Rationale

This International Standard is intended to be used to generate mechanical test data from reclosable child resistant packaging systems. These data may be used for the verification of equivalency of a child resistant packaging system to a type-approved package (e.g. in the course of change management) and aims to avoid unnecessary panel tests.

4.2 Reference data

Reference data shall be generated from type-approved packages using the testing methods specific to the packaging type as given in Clause 6. Reference data should preferably be generated on the same package lot(s) as used for type approval testing to ISO 8317. Where this is not possible, reference data may be generated on an alternative lot, or lots, of the package, providing that the package lot is identical in design, construction and specification to the type-approved package.

The identified test methods used to generate data from packages submitted for testing to ISO 8317, or from packages fulfilling the specification, shall be used to set the test parameters for the range of packaging covered by the original certification. Specifications with appropriate tolerances for the specific packaging shall be defined when generating reference data.

4.3 Package modifications

ISO 8317 establishes that mechanical testing may be used to confirm the continued compliance of child resistant packages, subject to minor changes to the package that was type-approved to ISO 8317.

NOTE Changes to a type-approved package that would result in the package being outside the criteria or dimensions of a series of similar packages, require panel testing according to ISO 8317 to confirm compliance as a child resistant package.

The suitability and ability of mechanical testing to assess the impact of changes to a type-approved child resistant package will vary according to the nature of the proposed changes. To decide upon this, for each proposed change, a risk assessment shall be conducted to identify the potential impacts of the proposed

change, and identify and assess the ability of the selected mechanical test methods to suitably measure those impacts. The risk assessment and the rationale for the selected test methods shall be recorded.

Only where the impact of any change on child resistance performance can be reliably measured and quantified by mechanical testing may mechanical testing alone be used to assess the continued compliance as a child resistant package. In all other circumstances, child and adult panel testing according to ISO 8317 shall be conducted.

Changes affecting the essential characteristics shall be thoroughly evaluated in the course of the risk assessment. The following elements are considered as essential characteristics of the container/closure system and are important to maintain the child resistant functionality:

a) Container

- critical dimensions;
- material: glass, metal, different polymers, etc.;
- shape: round, square, rectangular, oval, etc.;
- handling: handle position, handle design, etc.;
- thread: form, position;
- neck: position, orientation, design, etc.;
- rigidity.

b) Closure

- critical dimensions;
- material: metal, different polymers, etc.;
- shape: round, square, rectangular, oval, etc.;
- handling: external gripping feature;
- thread: form, position;
- child resistant system: push down and turn, squeeze and turn, etc.;
- sealing feature: wad-liner, plug, etc.

The decision making process for the application of mechanical testing of minor changes to a type-approved package is illustrated in Figure 1.

NOTE The mechanical test methods described in this International Standard are only capable of measuring unidirectional (vertical and lateral) compression and tension forces, and rotational torque; they cannot measure or quantify frictional or grip forces, for example, between a hand(s) and a package. Changes to a type-approved package that have the potential to impact the hand grip of a child or adult on the package cannot therefore be assessed by methods described in this International Standard.

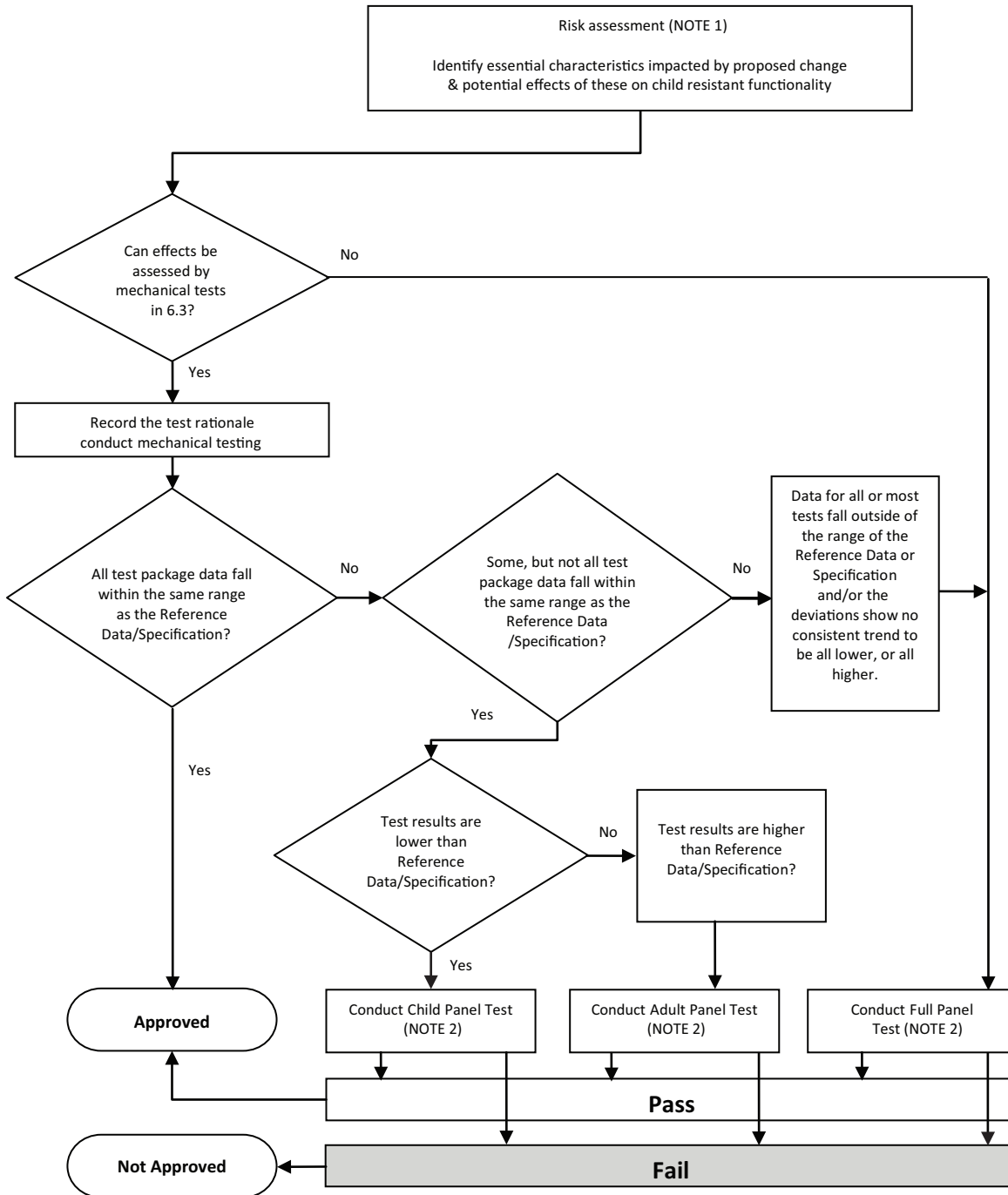

NOTE 1 The use of suitable risk assessment methodology should be considered (e.g. IEC ISO 31010).

NOTE 2 Or reject modification.

Figure 1 — Decision flowchart for the use of mechanical testing of modifications to a type-approved package

4.4 Testing facilities

Tests shall be carried out at a testing facility capable of meeting the operational provisions specified in ISO/IEC 17025.

NOTE This does not imply a requirement for accreditation but, if appropriate, such external approval may be obtained from either a national accreditation body or from the competent authority.

4.5 Test methods

A number of mechanical test methods for different types of packaging systems are given in Annexes A to J.

Commercially available test equipment with appropriate jigs and fixtures for the packaging under test may be used where appropriate.

4.6 Test method selection

Specific test methods, as given in 6.2, shall be chosen depending on the packaging type to be tested. Additional test methods identified by the risk assessment can also be applied after validation. Their use and the rationale for their use shall be recorded in the test report.

4.7 Component verification

It is the responsibility of the person(s) carrying out the mechanical test to ensure that the components match the specification and that all functional parts of the system are present.

5 Samples

5.1 Sample selection

Child resistant packages submitted for mechanical testing shall be new and unfilled. Some safety features will require the testing of individual components. Where the package depends for its child resistant properties on the interaction between two or more components (e.g. lugs on the container engaging with features on the cap) the system shall always be tested as a whole.

5.2 Sample preparation

A minimum of 10 samples per test shall be used.

Packages which incorporate an exterior and/or interior tamper-evident seal in addition to being child resistant shall have the seal broken.

Containers and closures shall be assembled and closed according to their specification. Where torque is required to apply the closure, the specified application torque shall be that recorded in the ISO 8317 test report for the certified package.

A sample of the test package shall be opened and properly reclosed to check its functionality. This sample shall then be discarded.

The assembled containers and closures shall be stored for 72 h at $(23 \pm 2)^\circ\text{C}$ and $(50 \pm 5)\%$ RH prior to conducting tests. This is to allow materials (e.g. closure or liner) to take "a set".

Testing shall be conducted immediately after conditioning of the packages.

NOTE It is recommended that assembly should not be carried out less than 24h after moulding to allow dimensional stability to be achieved.

6 Testing

6.1 Applicability of tests

For generation of reference data, the child resistant package shall undergo the specific tests given in 6.2. For modified packages, the system shall be tested according to the relevant tests in 6.2 as identified by the risk assessment described in 4.3. Additional tests may be applied if required.

6.2 Specific tests

6.2.1 Thread systems

6.2.1.1 Screw closure system

Torque release test: Annex A.

6.2.1.2 Squeeze and turn system

Squeeze test: Annex B.

Non-squeeze torque test: Annex C.

6.2.1.3 Push and turn system

Press down and turn engagement test: Annex D.

Push and turn test: Annex E.

Reverse ratchet torque test: Annex F.

Disassembly test: Annex G.

6.2.2 Snap-cap system

Rotational torque test: Annex H.

Push-off force: Annex I.

Application force: Annex J.

6.3 Assessment of test results

The test data of a modified package shall be compared with the relevant reference data for the package type as described in the test annexes.

7 Test report

7.1 General

Every test shall be accompanied by a test report, containing the following information.

7.2 Test facility (name and address)

This shall be the organization that undertook the actual testing. The front page of the report shall be on the headed paper of the test facility. If headed paper is not available, the report shall be clearly traceable to the author and the test facility.

7.3 Applicant (name and address)

The applicant can be the manufacturer, the user of the child resistant packaging or any person in the packaging chain.

NOTE In some instances the test facility and applicant address may be the same.

7.4 Report number

The report number shall appear on every page of the report and any annexes. Any subsequent amendments shall include the number and clearly show it is an amendment to or an addition to the original report.

7.5 Date

This shall be the date the report was completed, rather than the date that testing was completed. The report shall also include the date of the start and completion of the tests and the date of receipt of test items.

7.6 Manufacturer

The details of the manufacturer(s) of all of the components of the child resistant system shall be listed.

7.7 Packaging description

Full description of all components (e.g. closure, liner or container) of test specimens, including reference to the number and issue of drawings, dimensions, tolerances and material specifications for all components.

7.8 References

For changes to a certificated package, reference to the ISO 8317 certificate and the date it was issued shall be included.

The report shall enable full traceability back to the original test data.

7.9 Test description and results

The report shall identify the number of packages tested based on the basic sampling plan.

There shall be a description of each test and how it was performed, including preparation and conditioning.

There shall be a full description of any test performed that is not included in this International Standard and the rationale for its use.

The report shall contain reference test data for each test carried out, generated by the testing of the type-approved packages conforming to the ISO certificate.

The report shall contain tabulated test results for each test carried out, on each identified test specimen.

NOTE The raw data will be traced and archived by the test laboratory or premises.

The report shall include a conclusion clearly indicating the equivalency of the packaging, if applicable.

7.10 Signature

The test report shall be signed with the name and status of the signatory.

The person who was responsible for the testing shall sign the report against his or her typed name and position in the laboratory. That person might be the tester or his/her supervisor.

The report shall include the following statement: "The use of other packaging specification or components shall render it invalid".

Annex A (normative)

Torque release test

A.1 Equipment

A.1.1 **Torque tester**, accurate to $\pm 5\%$.

A.1.2 **Suitable jigs or clamps**, to restrain the container and grip the closure.

NOTE Care should be taken that the design of the jig or clamp minimizes distortion of the components.

A.2 Procedure

Assemble the container and closure in accordance with 5.2. Clamp the container on to the torque meter using a suitable jig or clamp so that the closure is aligned vertically. Grip the closure by hand or with the suitable jig or clamp and rotate the closure in an anticlockwise direction. Record the torque at which the closure opens.

A.3 Assessment of results

Use a *t*-test to determine whether there is a statistical difference between the test data and reference data.

If the test data are lower than the reference data, conduct a child panel test. If the test data are higher than the reference data, conduct an adult panel test.

Annex B (normative)

Squeeze test

B.1 Equipment

B.1.1 Means of measuring applied force (e.g. load cell), accurate to $\pm 5\%$.

B.1.2 Suitable jigs or clamps, to rotate the container and compress the closure.

NOTE Care should be taken that the design of the jig or clamp minimizes distortion of the components.

B.2 Procedure

Assemble the container and closure in accordance with 5.2. Rotate the closure anticlockwise until the lugs on the cap are in contact with the restraining lugs on the container. Progressively apply a load to opposite sides of the bottom of the skirt of the closure at right angles to the line of the lugs (or on the squeeze points indicated on the closure, if present) while applying a torque to the container (sufficient to open the container when the lugs are disengaged). Record the load at which the container turns, i.e. when the lugs just disengage.

B.3 Assessment of results

Use a *t*-test to determine whether there is a statistical difference between the test data and reference data.

If the test data are lower than the reference data, conduct a child panel test. If the test data are higher than the reference data, conduct an adult panel test.

Annex C (normative)

Non-squeeze torque test

C.1 Reference test method

C.1.1 Equipment

C.1.1.1 **Torque tester**, accurate to $\pm 5\%$.

C.1.1.2 **Suitable jigs or clamps**, to restrain the container and grip the closure.

NOTE Care should be taken that the design of the jig or clamp minimizes distortion of the components.

C.1.2 Procedure

Assemble the container and closure in accordance with 5.2. Clamp the container on to the torque meter using a suitable jig or clamp so that the closure is aligned vertically. Grip the closure by hand or with a suitable jig or clamp and rotate the closure without squeezing in an anticlockwise direction. Record the torque required to remove the closure.

If the torque exceeds 3,5 Nm, the test may be terminated.

C.2 Alternative test method

ASTM D3198 is an acceptable alternative that may be used to meet the requirements of this International Standard.

C.3 Assessment of results

If the test results are higher than the reference tests or if the torque was greater than 3,5 Nm, no action is required.

Otherwise, use a *t*-test to determine whether there is a statistical difference between the test data and reference data.

If there is a statistical difference between the test data and reference data, conduct a child panel test.

Annex D (normative)

Press down and turn engagement test

D.1 Equipment

D.1.1 Means of measuring applied force (e.g. load cell), accurate to $\pm 5\%$.

D.1.2 Suitable jigs or clamps, to restrain the container and grip the closure.

NOTE Care should be taken that the design of the jig or clamp minimizes distortion of the components.

D.2 Procedure

Assemble the container and closure in accordance with 5.2. Clamp the container using a suitable jig or clamp so that the closure is aligned vertically. Apply a progressively increasing normal force to the closure while at the same time attempting to open the package by rotating the closure. Record the applied force at the point at which the closure can be rotated to open the package

NOTE This force is most easily applied by the incremental addition of deadweights.

D.3 Assessment of results

Use a *t*-test to determine whether there is a statistical difference between the test data and reference data.

If the test data are lower than the reference data, conduct a child panel test. If the test data are higher than the reference data, conduct an adult panel test.

Annex E (normative)

Push and turn test

E.1 Equipment

E.1.1 **Torque tester**, accurate to $\pm 5\%$.

E.1.2 **Suitable jigs or clamps**, to restrain the container and grip the closure.

NOTE Care should be taken that the design of the jig or clamp minimizes distortion of the components.

E.2 Procedure

Assemble the container and closure in accordance with 5.2. Clamp the container on the torque meter using a suitable jig or clamp so that the closure is aligned vertically. Apply a normal force to the closure, of sufficient magnitude to engage the mechanism. Grip the closure and rotate the closure in an anticlockwise direction. Record the torque required to open the closure.

E.3 Assessment of results

Use a *t*-test to determine whether there is a statistical difference between the test data and reference data.

If the test data are lower than the reference data, conduct a child panel test. If the test data are higher than the reference data, conduct an adult panel test.

Annex F (normative)

Reverse ratchet torque test

F.1 Reference method

Assemble the container and closure in accordance with 5.2.

Manually rotate the closure through 10 revolutions in an anticlockwise direction, without applying a downward force. The closure shall not open.

F.2 Alternative test method

ASTM D3472 is an acceptable alternative that may be used to meet the requirements of this International Standard.

All measured values of the reverse-ratchet torque shall be less than the minimum release torque for the closure, measured according to Annex E.

F.3 Assessment of results

If the requirements of the chosen test method are not met, the package can no longer be regarded as child resistant and the modification shall be rejected.

Annex G (normative)

Disassembly test

G.1 Applicability of tests

If using the test to assess only a change to the closure, the reference test method or alternative method may be used.

If using the test to assess a change to the container, or the container and closure, the alternative test method shall be used.

G.2 Reference test

G.2.1 Equipment

G.2.1.1 Guided metal rod, threaded at the top to fit the closure under test.

G.2.1.2 Metal collar with the top face machined at 3° from the horizontal. The hole in the collar shall be larger in diameter than the inner (threaded) part of the closure but smaller than the outer shell (see Figures G.1 and G.2).

G.2.1.3 Means of measuring applied force, accurate to $\pm 5\%$.

G.2.1.4 Universal testing machine or deadweights.

G.2.2 Procedure

Screw the closure onto the metal rod and pass it through the collar until the outer shell of the closure rests on the slanted face of the collar. Progressively apply a tensile load to the rod (e.g. by the incremental addition of deadweights or using a universal testing machine). Record the force required to separate the shell from the inner part of the closure.

G.3 Assessment of results

Use a *t*-test to determine whether there is a statistical difference between the test data and reference data.

If the test data are lower than the reference data, conduct a child panel test. If the test data are higher than the reference data, the modification can be accepted without further testing.

If the separation force is greater than 50 N for cap diameters up to and including 28mm, or 40 N for cap diameters over 28mm, the modification can be accepted without further testing

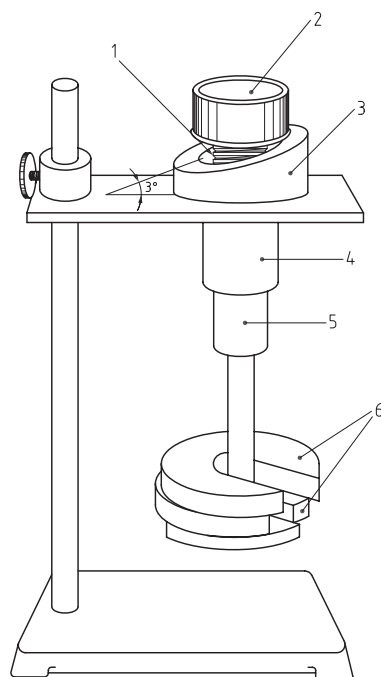

Key

- 1 shaft with thread screwed into inner closure
- 2 closure
- 3 collar (to suit closure size) supporting outer shell
- 4 guide
- 5 shaft (sliding fit in guide)
- 6 weights

Figure G.1 — Example of apparatus for testing separation force using deadweights

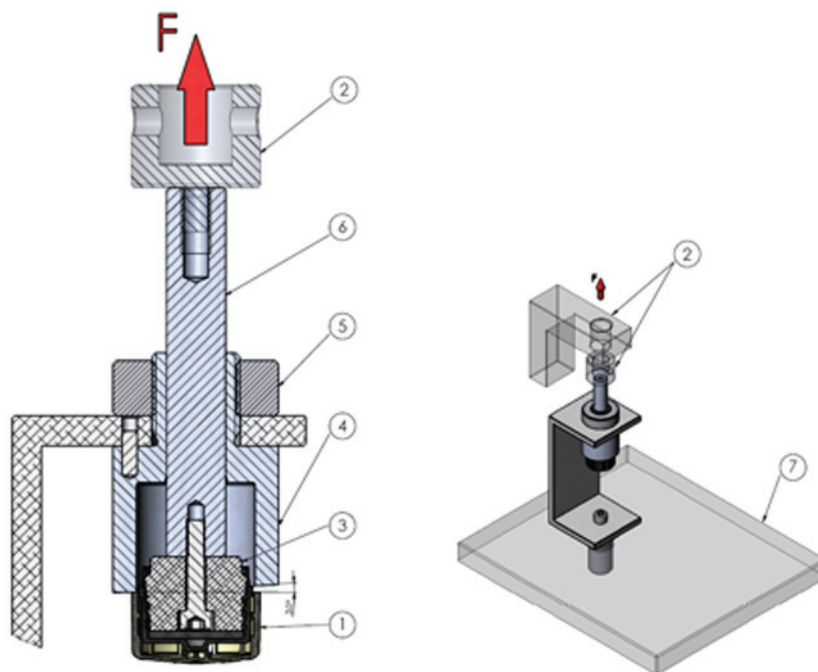

Key

- 1 screw cap
- 2 machine connector
- 3 thread adaptor
- 4 tapered load applicator
- 5 fixture
- 6 pull rod
- 7 machine table

Figure G.2 — Example of apparatus for testing separation force using a universal testing machine

G.4 Alternative test method

ASTM D3481 is an acceptable alternative that may be used to meet the requirements of this International Standard.

Annex H (normative)

Rotational torque test

H.1 Reference test

H.1.1 Equipment

H.1.1.1 **Torque tester**, accurate to $\pm 5\%$.

H.1.1.2 **Suitable jigs or clamps**, to restrain the container and grip the closure.

NOTE Care should be taken that the design of the jig or clamp minimizes distortion of the components.

H.1.2 Procedure

Assemble the container and closure in accordance with 5.2. Clamp the container on to the torque meter using a suitable jig or clamp so that the closure is aligned vertically. Grip the closure with a suitable jig or clamp and rotate the closure. Record the torque required to rotate the closure through 360° or the maximum possible arc from stop to alignment point.

H.2 Alternative test method

ASTM D3968 is an acceptable alternative that may be used to meet the requirements of this International Standard.

H.3 Assessment of results

Use a *t*-test to determine whether there is a statistical difference between the test data and reference data.

If the test data are lower than the reference data, conduct a child panel test. If the test data are higher than the reference data, conduct an adult panel test.

Annex I (normative)

Push-off force

I.1 Equipment

I.1.1 Push-off probe, capable of being inserted between the skirt of the closure and any flange on the container.

NOTE A steel probe 1mm thick and 5mm wide at the tip is recommended.

I.1.2 Means of measuring applied force (e.g. load cell), accurate to $\pm 5\%$.

I.1.3 Suitable jigs or clamps, to restrain the container.

NOTE Care should be taken that the design of the jig or clamp minimizes distortion of the components.

I.2 Procedure

I.2.1 Correctly aligned push-off force

Assemble the container and closure in accordance with 5.2. Securely clamp the container to prevent movement when the push-off force is applied. Align the marks on the container and closure. Locate the lip of the probe under the skirt of the closure directly below the lift-off tab and smoothly apply a force upwards. Record the force at which the closure separates from the container.

I.2.2 Incorrectly aligned push-off force

Assemble the container and closure in accordance with 5.2. Securely clamp the container to prevent movement when the push-off force is applied. Align the marks on the container and closure at 180 degrees to each other. Locate the lip of the probe under the skirt of the closure directly below the lift-off tab and smoothly apply a force upwards. Record the force at which the closure separates from the container.

I.3 Assessment of results

Use a *t*-test to determine whether there is a statistical difference between the test data and reference data.

If the test data are lower than the reference data, conduct a child panel test. If the test data are higher than the reference data, conduct an adult panel test.

Annex J (normative)

Application force

J.1 Equipment

J.1.1 Means of measuring applied force (e.g. load cell), accurate to $\pm 5\%$.

J.1.2 Suitable jigs or clamps, to restrain the container and grip the closure.

NOTE Care should be taken that the design of the jig or clamp minimizes distortion of the components.

J.2 Procedure

Assemble the container and closure in accordance with 5.2. Clamp the container using a suitable jig or clamp so that the closure is aligned vertically. Place the closure loosely on the container neck. Align the marks on the container and closure at 180 degrees to each other. Apply a vertical force evenly to the closure to push it on to the container. Record the force needed for the closure to engage with the container.

J.3 Assessment of results

Use a *t*-test to determine whether there is a statistical difference between the test data and reference data.

If the test data are higher than the reference data, conduct an adult panel test.

Bibliography

- [1] ISO 9001, *Quality management systems — Requirements*
- [2] ISO/IEC 31010, *Risk management — Risk assessment techniques*
- [3] ISO/IEC 17025, *General requirements for the competence of testing and calibration laboratories*
- [4] ASTM D3198, *Standard Test Method for Application and Removal Torque of Threaded or Lug-Style Closures*
- [5] ASTM D3472, *Standard Test Method for Reverse Ratchet Torque of Type 1A Child Resistant Closures*
- [6] ASTM D3481, *Standard Test Method for Manual Shelling Two-Piece Child-Resistant Closures That Are Activated by Two Simultaneous Dissimilar Motions*
- [7] ASTM D3968, *Standard Test Method for Monitoring of Rotational Torque of Type IIIA Child Resistant Closures*

British Standards Institution (BSI)

BSI is the national body responsible for preparing British Standards and other standards-related publications, information and services.

BSI is incorporated by Royal Charter. British Standards and other standardization products are published by BSI Standards Limited.

About us

We bring together business, industry, government, consumers, innovators and others to shape their combined experience and expertise into standards-based solutions.

The knowledge embodied in our standards has been carefully assembled in a dependable format and refined through our open consultation process. Organizations of all sizes and across all sectors choose standards to help them achieve their goals.

Information on standards

We can provide you with the knowledge that your organization needs to succeed. Find out more about British Standards by visiting our website at bsigroup.com/standards or contacting our Customer Services team or Knowledge Centre.

Buying standards

You can buy and download PDF versions of BSI publications, including British and adopted European and international standards, through our website at bsigroup.com/shop, where hard copies can also be purchased.

If you need international and foreign standards from other Standards Development Organizations, hard copies can be ordered from our Customer Services team.

Subscriptions

Our range of subscription services are designed to make using standards easier for you. For further information on our subscription products go to bsigroup.com/subscriptions.

With **British Standards Online (BSOL)** you'll have instant access to over 55,000 British and adopted European and international standards from your desktop. It's available 24/7 and is refreshed daily so you'll always be up to date.

You can keep in touch with standards developments and receive substantial discounts on the purchase price of standards, both in single copy and subscription format, by becoming a **BSI Subscribing Member**.

PLUS is an updating service exclusive to BSI Subscribing Members. You will automatically receive the latest hard copy of your standards when they're revised or replaced.

To find out more about becoming a BSI Subscribing Member and the benefits of membership, please visit bsigroup.com/shop.

With a **Multi-User Network Licence (MUNL)** you are able to host standards publications on your intranet. Licences can cover as few or as many users as you wish. With updates supplied as soon as they're available, you can be sure your documentation is current. For further information, email bsmusales@bsigroup.com.

BSI Group Headquarters

389 Chiswick High Road London W4 4AL UK

Revisions

Our British Standards and other publications are updated by amendment or revision.

We continually improve the quality of our products and services to benefit your business. If you find an inaccuracy or ambiguity within a British Standard or other BSI publication please inform the Knowledge Centre.

Copyright

All the data, software and documentation set out in all British Standards and other BSI publications are the property of and copyrighted by BSI, or some person or entity that owns copyright in the information used (such as the international standardization bodies) and has formally licensed such information to BSI for commercial publication and use. Except as permitted under the Copyright, Designs and Patents Act 1988 no extract may be reproduced, stored in a retrieval system or transmitted in any form or by any means – electronic, photocopying, recording or otherwise – without prior written permission from BSI. Details and advice can be obtained from the Copyright & Licensing Department.

Useful Contacts:

Customer Services

Tel: +44 845 086 9001

Email (orders): orders@bsigroup.com

Email (enquiries): cservices@bsigroup.com

Subscriptions

Tel: +44 845 086 9001

Email: subscriptions@bsigroup.com

Knowledge Centre

Tel: +44 20 8996 7004

Email: knowledgecentre@bsigroup.com

Copyright & Licensing

Tel: +44 20 8996 7070

Email: copyright@bsigroup.com



...making excellence a habit.™